

DOKUMENTACJA TECHNICZNO-RUCHOWA



KRAKOWSKA FABRYKA
APARATOW POMIAROWYCH
"MERA-KFAP"

Pamięć na dyskach elastycznych
z formaterem i selektorem typ SP 45 DE

Tom II

Schematy logiczne

Tom II

Spis treści :

- Wykaz sygnałów złącz X /wszystkie płyty/
- Płyta SP45 I/O - wykaz sygnałów złącz Y
- Płyta SP45 I/O - schemat ideowy
- Płyta SP45 CPU; SP45 ROM/RAM - wykaz sygnałów złącza Y
- Płyta SP45 CPU - schemat ideowy
- Płyta SP45 ROM/RAM - schemat ideowy
- Płyta SP45 SEL ; wykaz sygnałów złącza Y
- Płyta SP45 SEL - schemat ideowy

Wykaz sygnałów złącz X /wszystkie płyty/

1	-	+5V	29	-	EXS	57	-	OR10
2	-	OV	30	-	RAZS	58	-	OR9
3	-	+5V	31	-	S1	59	-	OR12
4	-	OV	32	-	S2	60	-	OR11
5	-	APS1	33	-	S3	61	-	OR14
6	-	APS2	34	-	S4	62	-	OR13
7	-	APS3	35	-	S5	63	-	OR16
8	-	APS4	36	-	S6	64	-	OR15
9	-	APS5	37	-	S7	65	-	A2
10	-	APS6	38	-	S8	66	-	A7
11	-	APS7	39	-	JIMID	67	-	A4
12	-	SU1	40	-	PRLY	68	-	A3
13	-	SU2	41	-	WALT	69	-	A6
14	-	DI	42	-	RIN	70	-	A5
15	-	FA	43	-	MIN	71	-	A8
16	-	EL	44	-	OLK	72	-	A7
17	-	VE	45	-	VALINT	73	-	Y2
18	-	IT	46	-	WX/1	74	-	Y1
19	-	MU	47	-	STP+NOP	75	-	Y4
20	-	ED	48	-	INTD	76	-	Y3
21	-	WTCLK	49	-	OR2	77	-	Y6
22	-	RS	50	-	OR1	78	-	Y5
23	-	IM	51	-	OR4	79	-	Y8
24	-	UNP	52	-	OR3	80	-	Y7
25	-	SH	53	-	OR6	81	-	NCI
26	-	BL	54	-	OR5	82	-	OV
27	-	SD	55	-	OR8	83	-	NCII
28	-	MF	56	-	OR7	84	-	OV

Płyta SP45 I/O - wykaz sygnałów złącza Y

1	-	MU	29	-	O-DO8	57	-	O-AS3
2	-	OV, O-MU, O-FA	30	-	DC	58	-	CM3
3	-	FA	31	-	O-DC	59	-	O-CM3
4	-	OV, O-DI, O-PSS	32	-	CP	60	-	AP4
5	-	DI	33	-	O-CP	61	-	O-AP4
6	-	SU2	34	-	PC	62	-	AS4
7	-	PSS	35	-	O-PC	63	-	O-AS4
8	-	SU1	36	-	PE	64	-	CM4
9	-	O-SU1, O-SU2	37	-	O-PE	65	-	O-CM4
10	-	RZZ	38	-	EX	66	-	AP5
11	-	O-RZZ	39	-	O-EX	67	-	O-AP5
12	-	RZF	40	-	FE	68	-	AS5
13	-	O-RZF	41	-	O-FE	69	-	O-AS5
14	-	DO1	42	-	AP1	70	-	CM5
15	-	O-DO1	43	-	O-AP1	71	-	O-CM5
16	-	DO2	44	-	AS1	72	-	AP6
17	-	O-DO2	45	-	O-AS1	73	-	O-AP6
18	-	DO3	46	-	CM1	74	-	CM6
19	-	O-DO3	47	-	O-CM1	75	-	O-CM6
20	-	DO4	48	-	AP2	76	-	AP7
21	-	O-DO4	49	-	O-AP2	77	-	O-AP7
22	-	DO5	50	-	AS2	78	-	CM7
23	-	O-DO5	51	-	O-AS2	79	-	O-CM7
24	-	DO6	52	-	CM2	80	-	CM8
25	-	O-DO6	53	-	O-CM2	81	-	+5V
26	-	DO7	54	-	AP3	82	-	OV, O-DM8
27	-	O-DO7	55	-	O-AP3	83	-	+5V
28	-	DO8	56	-	AS3	84	-	OV

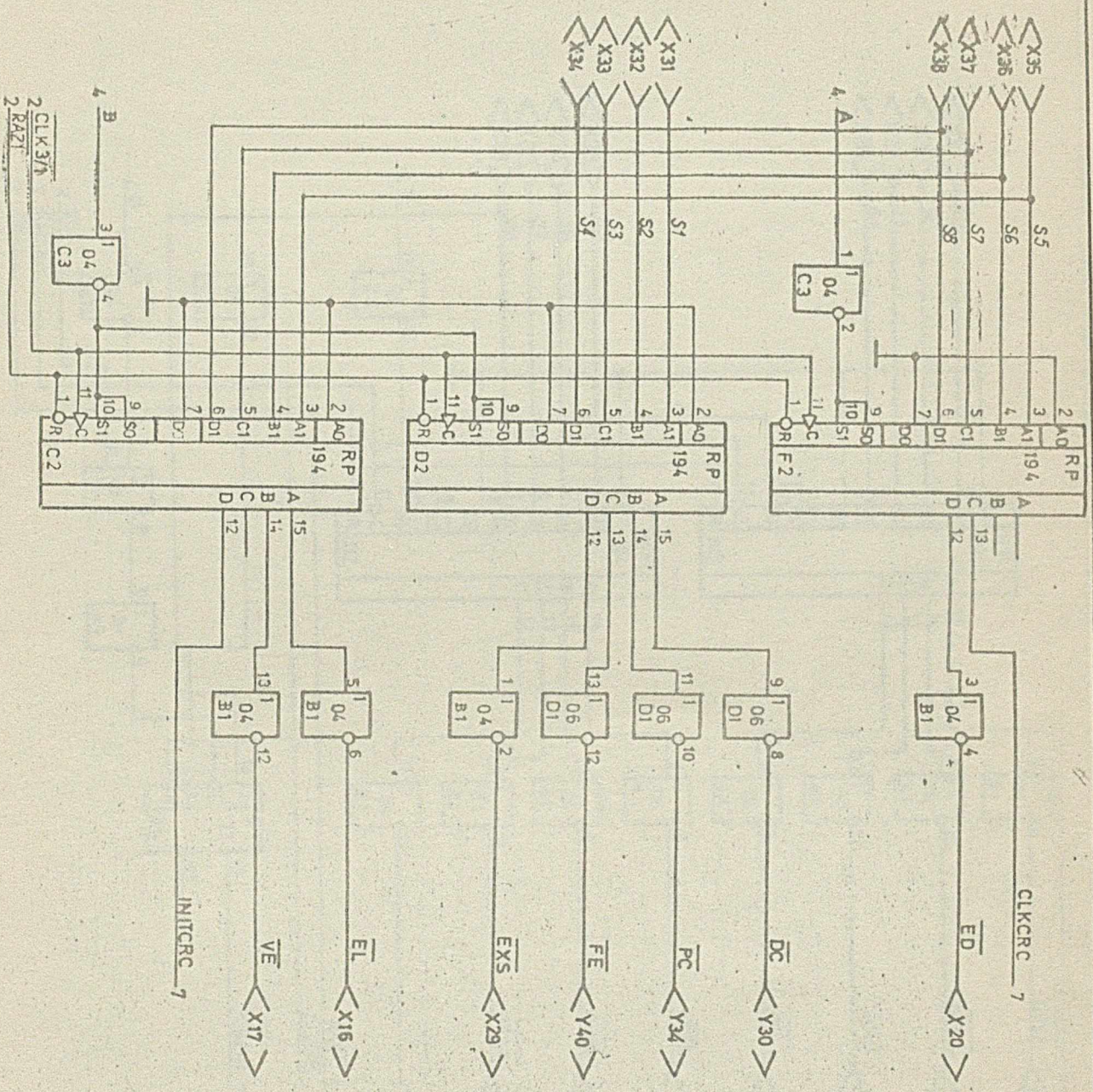

Typ: TYS
Płyta SP 451/0
schemat ideowy - ark. 1/11

Nr. TYS
3-L-36785

412

A115

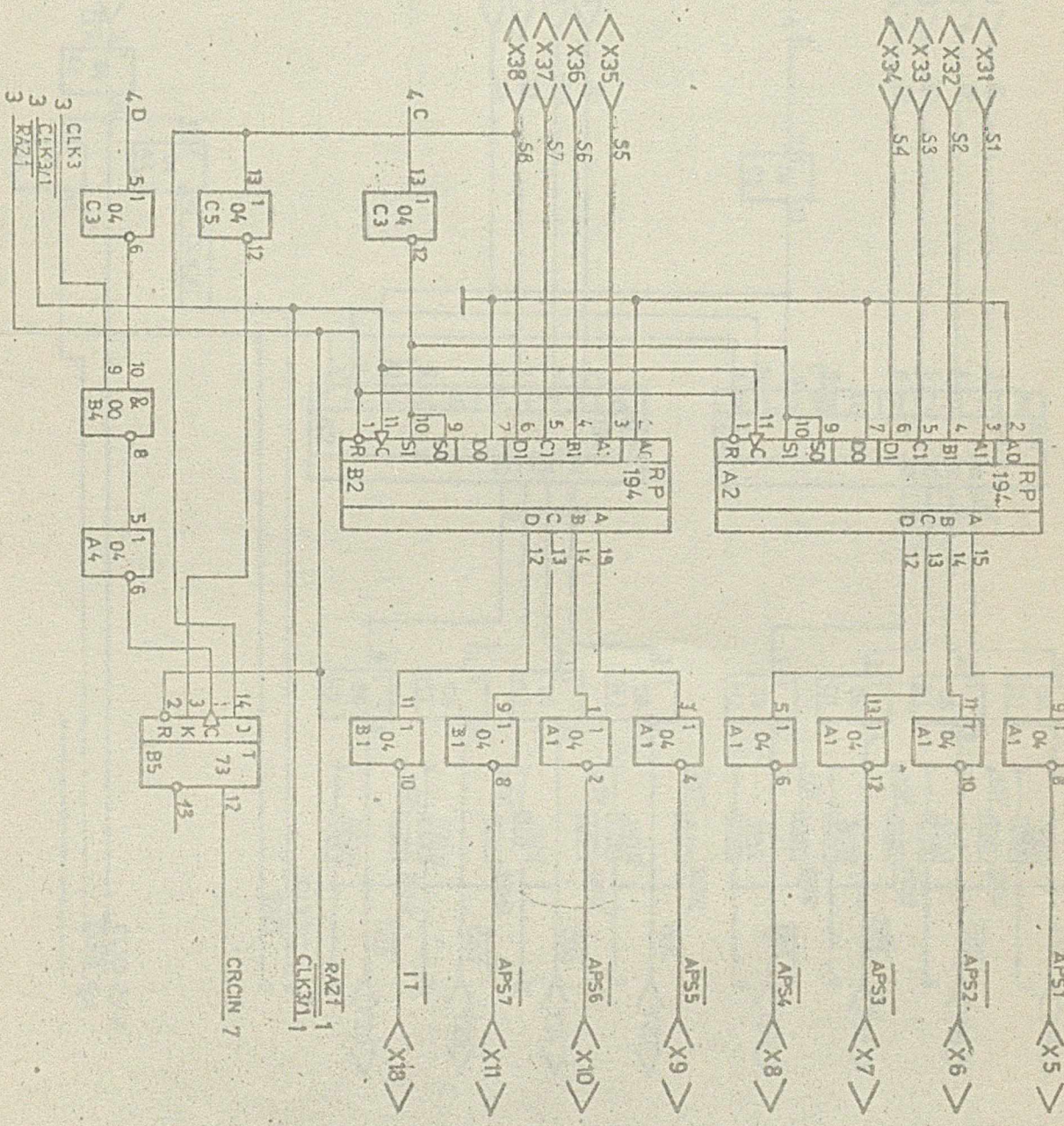

Typu 5
 Płyta SP45 I/O
 Schemat ideowy - drk. 2/11

Nr rys
 3-Z-36785

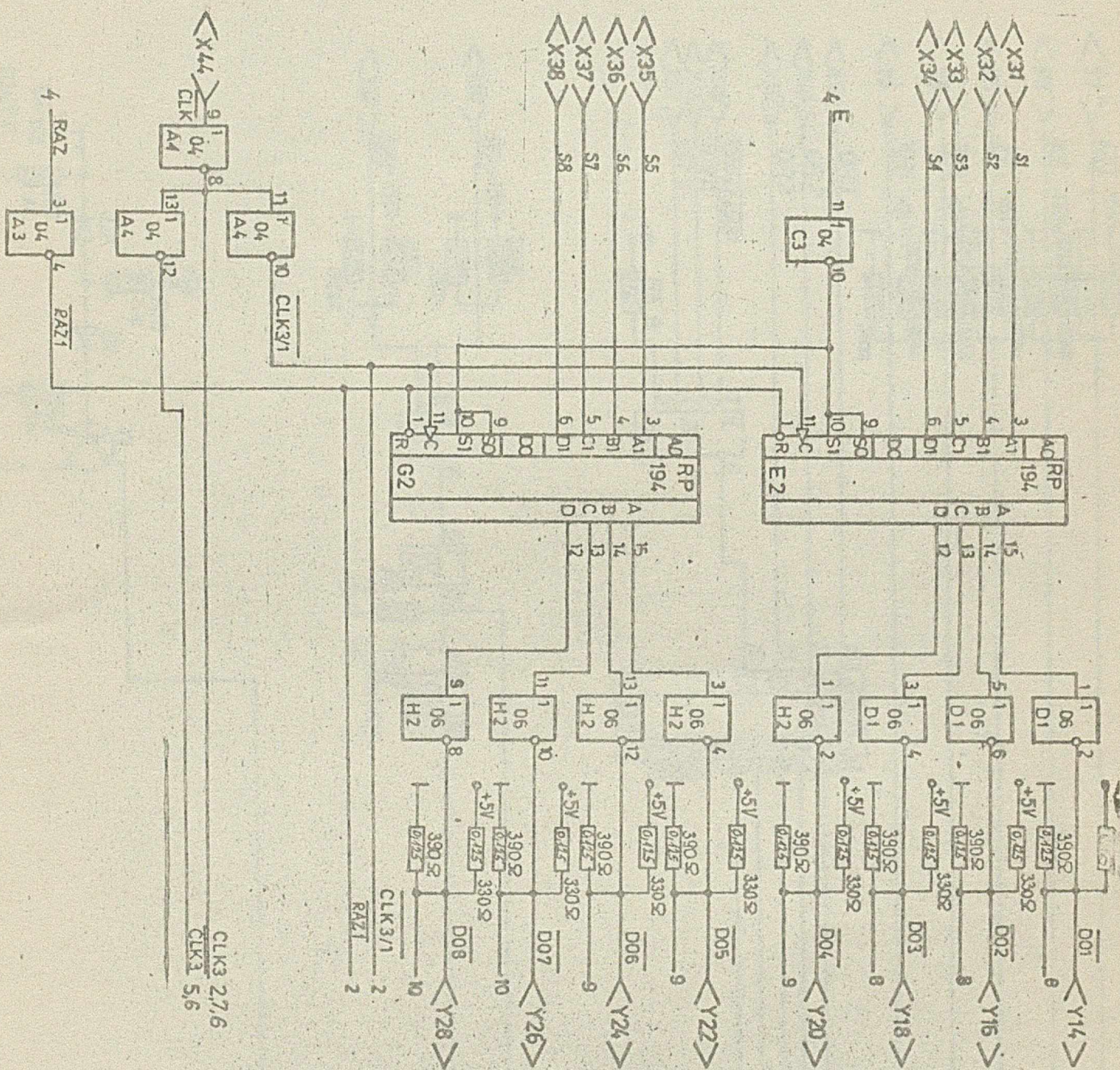

74138
 Pytia SP451/0
 Schematic diagram, part 2 / 11
 Nr. 745
 3-L-36785

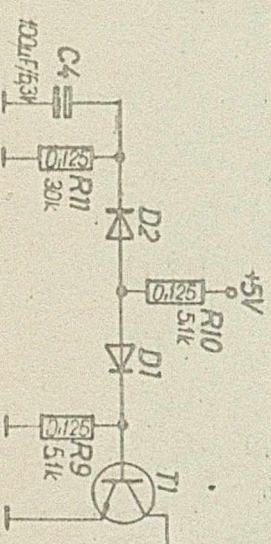
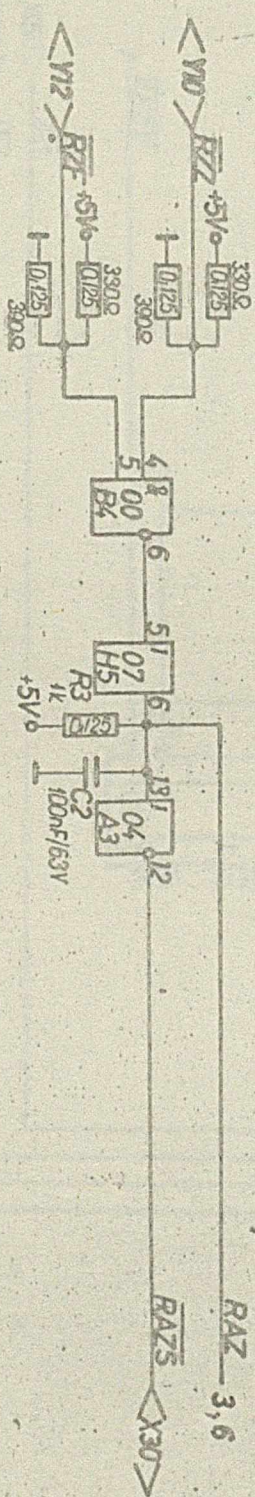
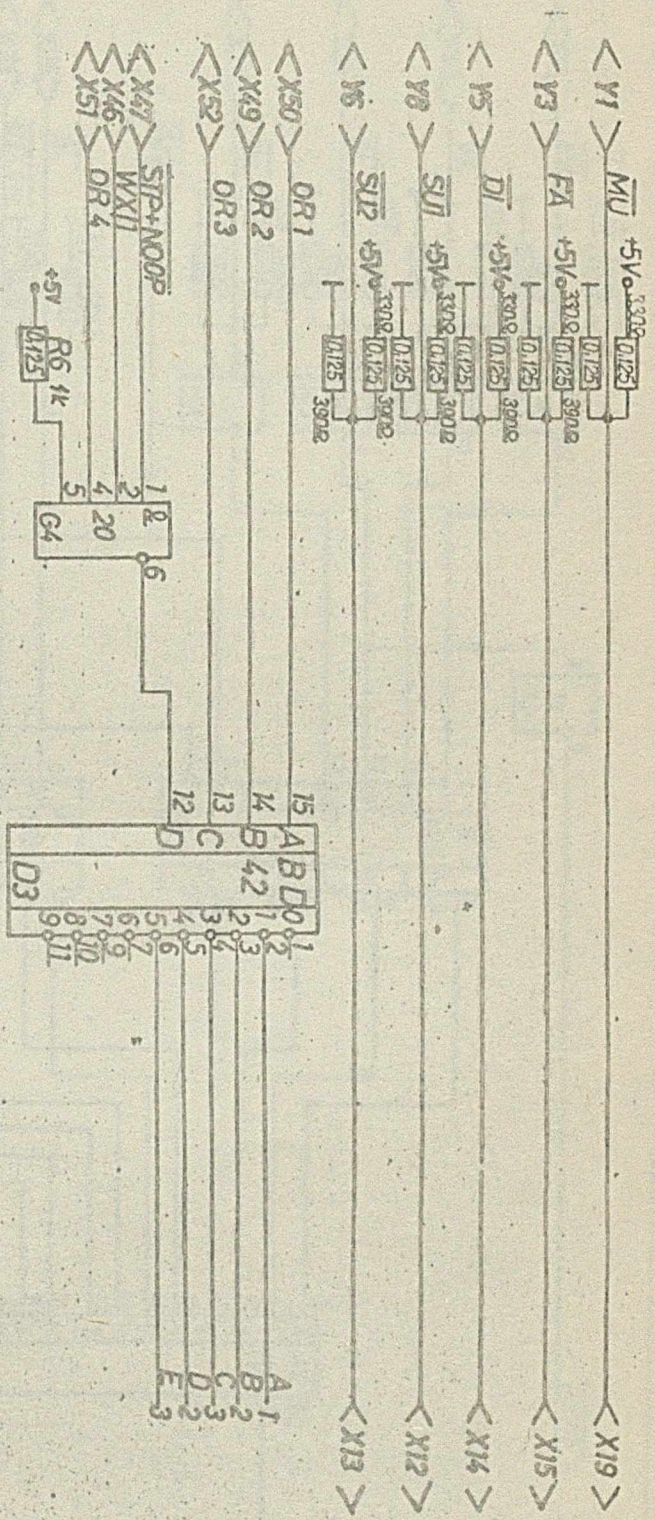

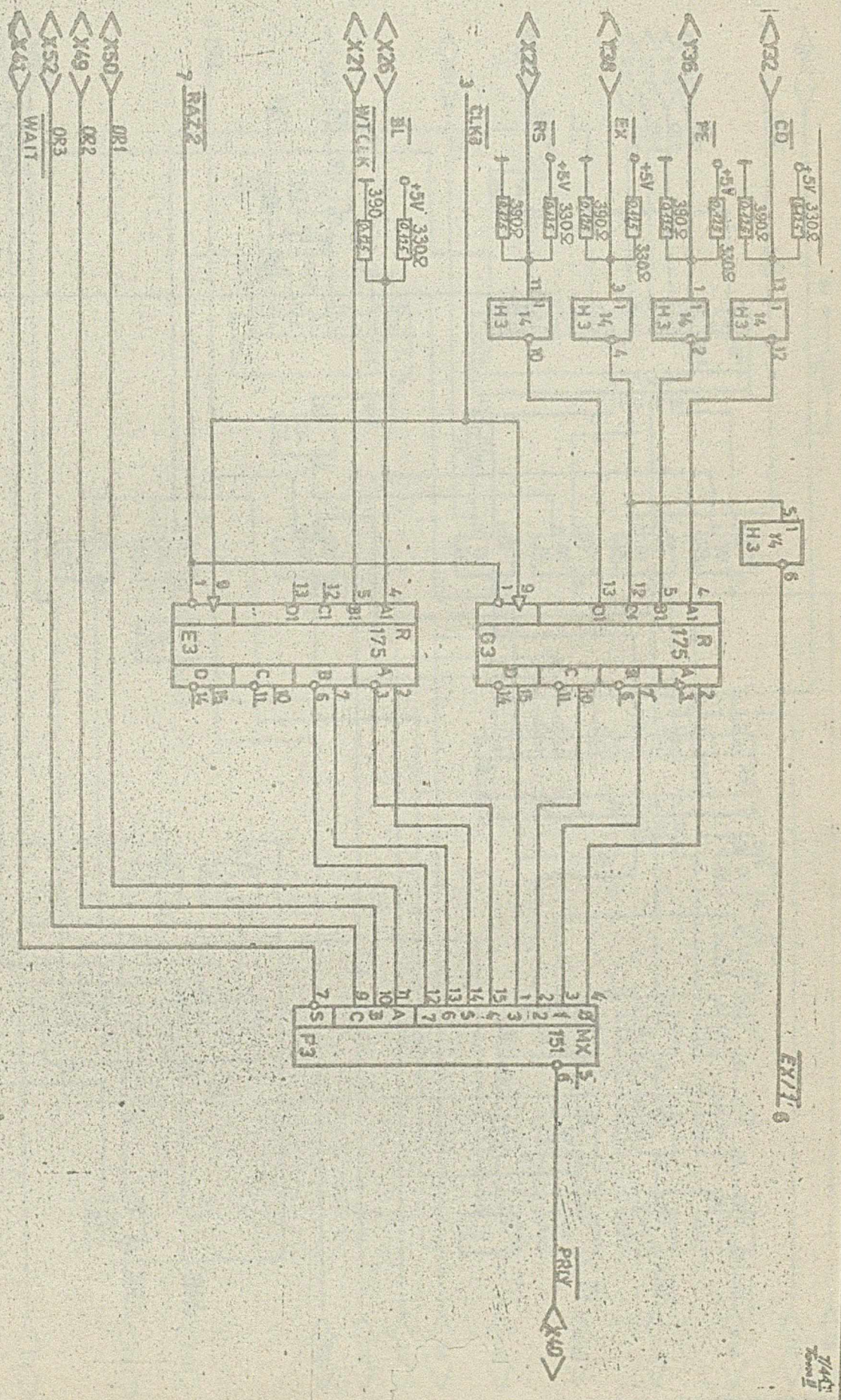

Typo 05
 Pyta SP 45 I / O
 schemat ideowy - ark. 5/11
 M/gb
 3-4-36785

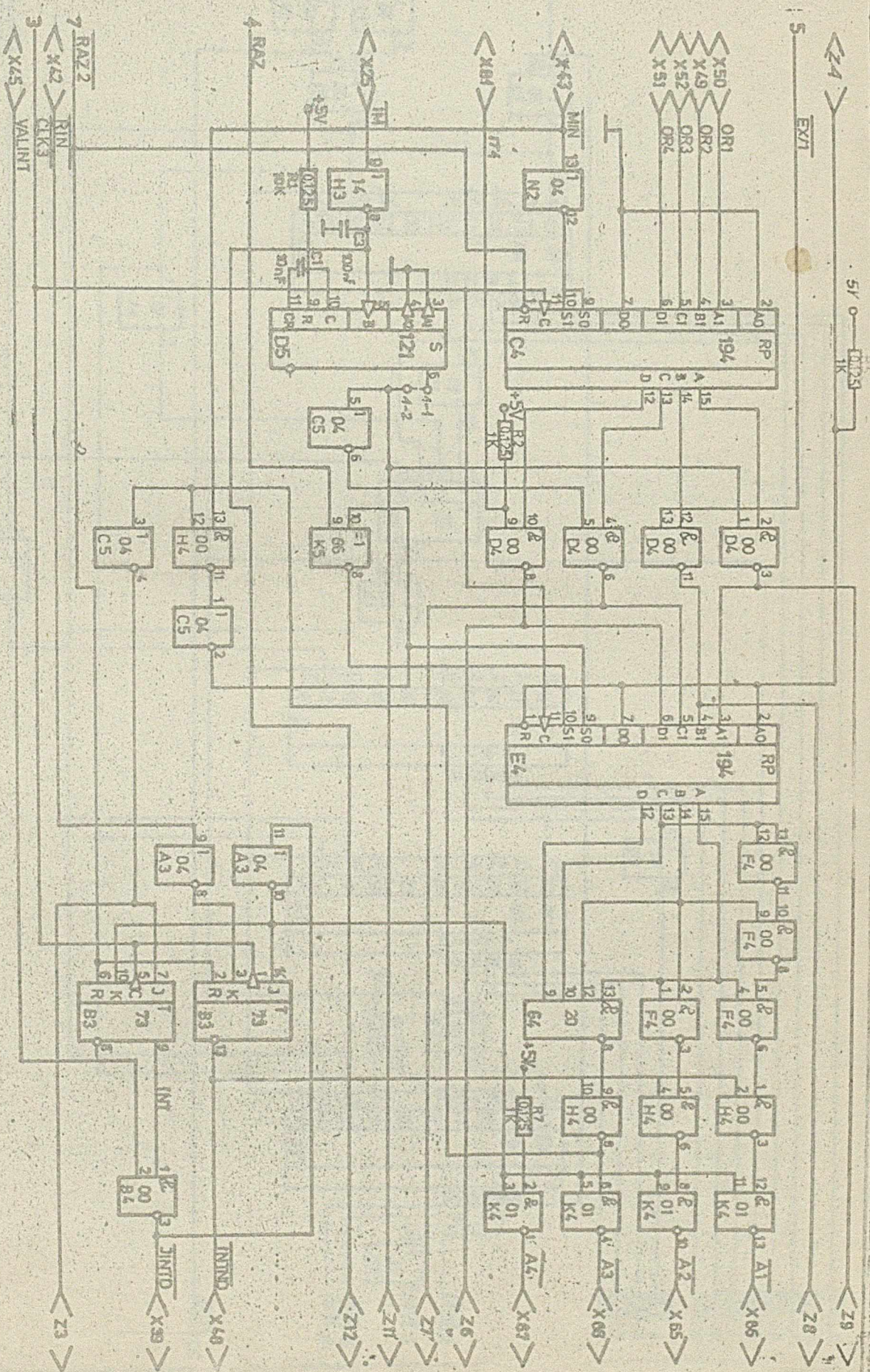

Wyk. 5/75
 Płyta SP45 I/O
 schemat ideowy - drk. 6/11
 Nr 12A
 3-1-36785

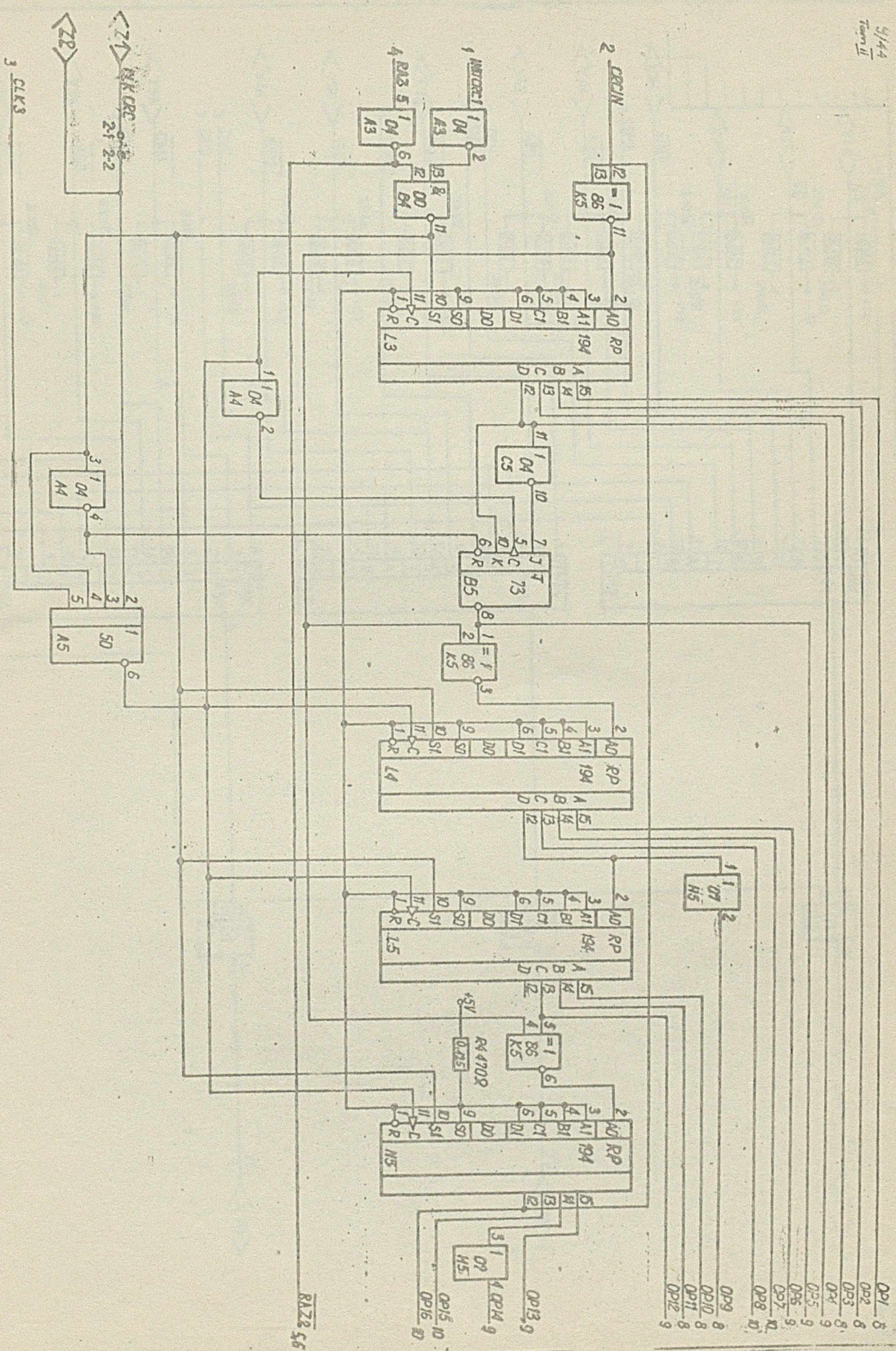

- OP1 5
- OP2 8
- OP3 8
- OP4 8
- OP5 9
- OP6 9
- OP7 9
- OP8 9
- OP9 8
- OP10 8
- OP11 8
- OP12 9

BA22 56

TUTU 75
Pyta SP 45 I/O
Schemat ideowy-artk 7/11

Nr rys
3-4-36785

114

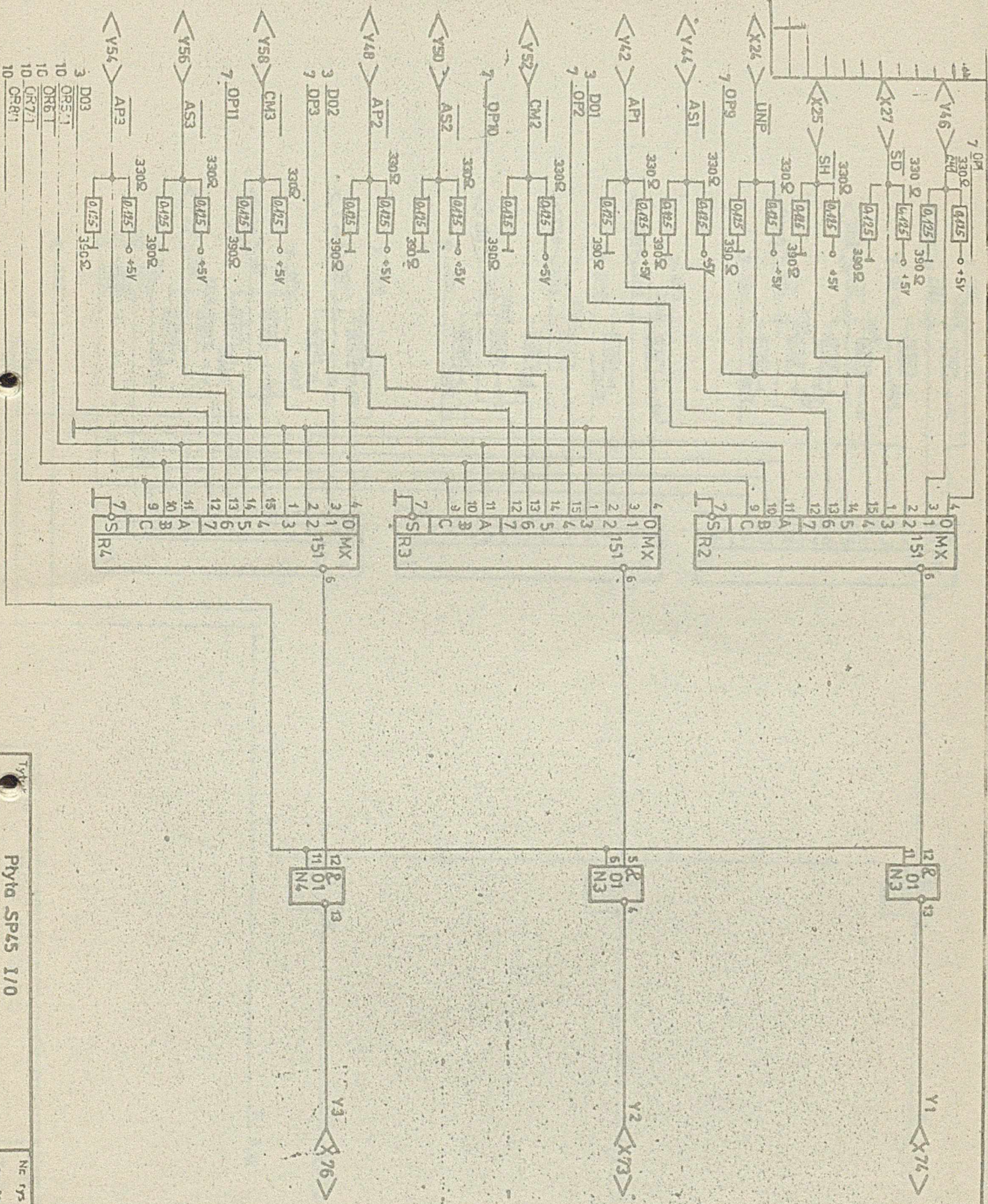

Pyta SP45 I/O
 schemat ideowy - ark. 8/11

NE 775
 3-L-36785

10/11
 1000 II

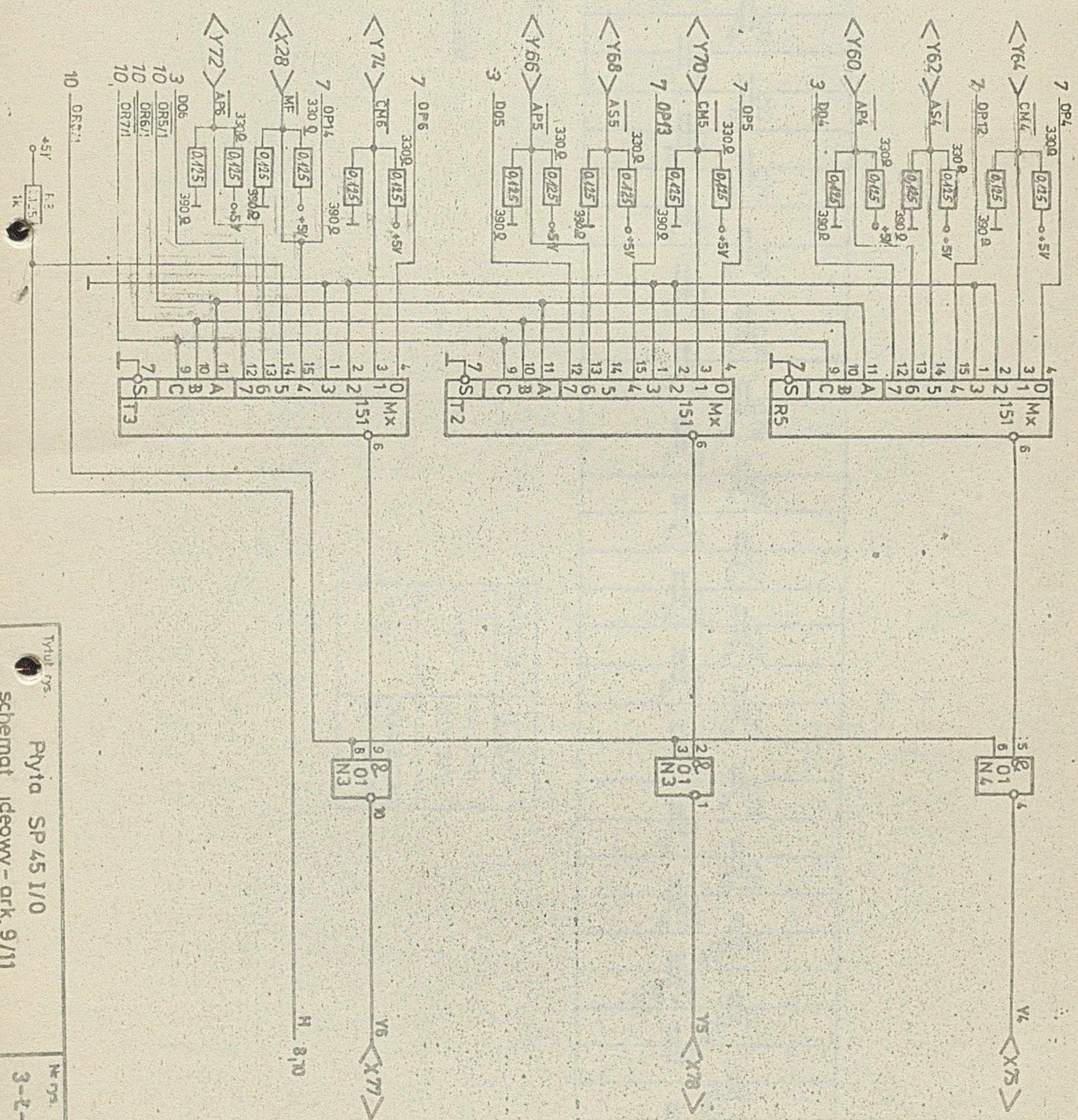

Pytia SP 45 I/O
 schemat ideowy - ark. 9/11

11/4
 Tom II

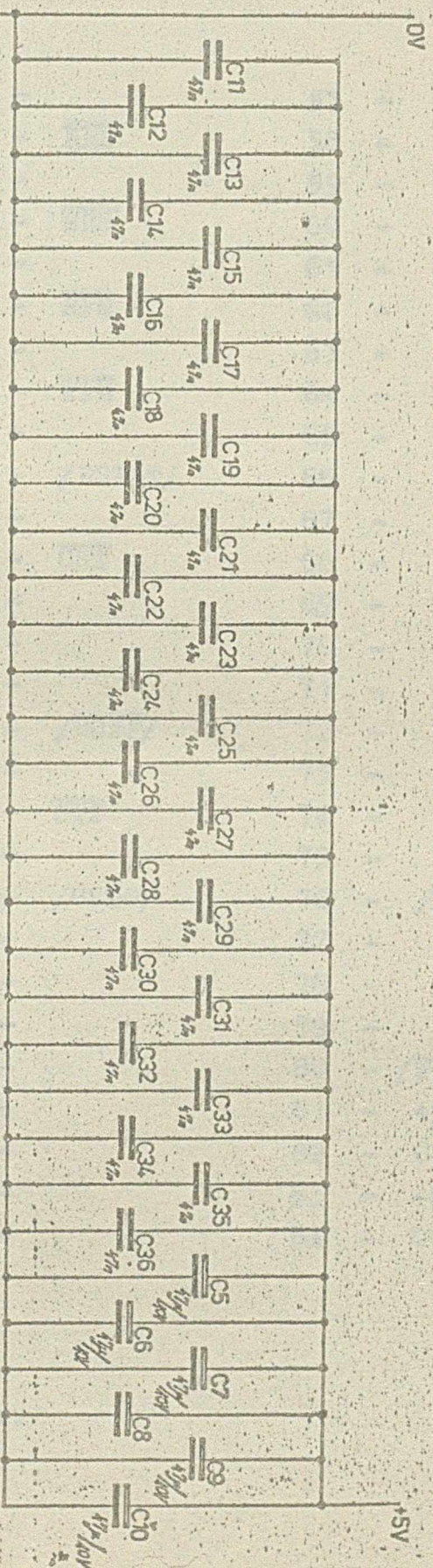

Wolne styki: 83X

Zasilanie	Nr styku
+5V	1X; 3X; 81Y; 83Y;
0V	2X, 4X, 82X, 84X 2Y, 4Y, 82Y, 84Y

Płyta SP45 CPU i SP45 ROM/RAH - wykaz sygnałów złącza I

1 -		29 -		57 -	
2 -	OV	30 -	RES	58 -	
3 -		31 -		59 -	
4 -	OV	32 -	SRS	60 -	
5 -	X1	33 -		61 -	
6 -	X2	34 -	RPM	62 -	
7 -	X3	35 -		63 -	
8 -	X4	36 -	WTM	64 -	
9 -	X5	37 -		65 -	
10 -	X6	38 -	/DSTAT/	66 -	
11 -	X7	39 -		67 -	
12 -	X8	40 -	CST	68 -	
13 -		41 -		69 -	
14 -	JIR	42 -		70 -	
15 -		43 -		71 -	
16 -	JEX	44 -	/MCF/	72 -	
17 -		45 -		73 -	
18 -	WPJ	46 -	STP	74 -	
19 -		47 -		75 -	
20 -	JIS	48 -	/CSTO/	76 -	/PROLK/
21 -		49 -		77 -	
22 -	REJ	50 -		78 -	
23 -		51 -		79 -	
24 -	JRO	52 -		80 -	/WAITM/
25 -		53 -		81 -	+5V
26 -	JUC	54 -		82 -	OV
27 -		55 -		83 -	+5V
28 -	WPI	56 -		84 -	OV

/.../ - tylko do testowania.

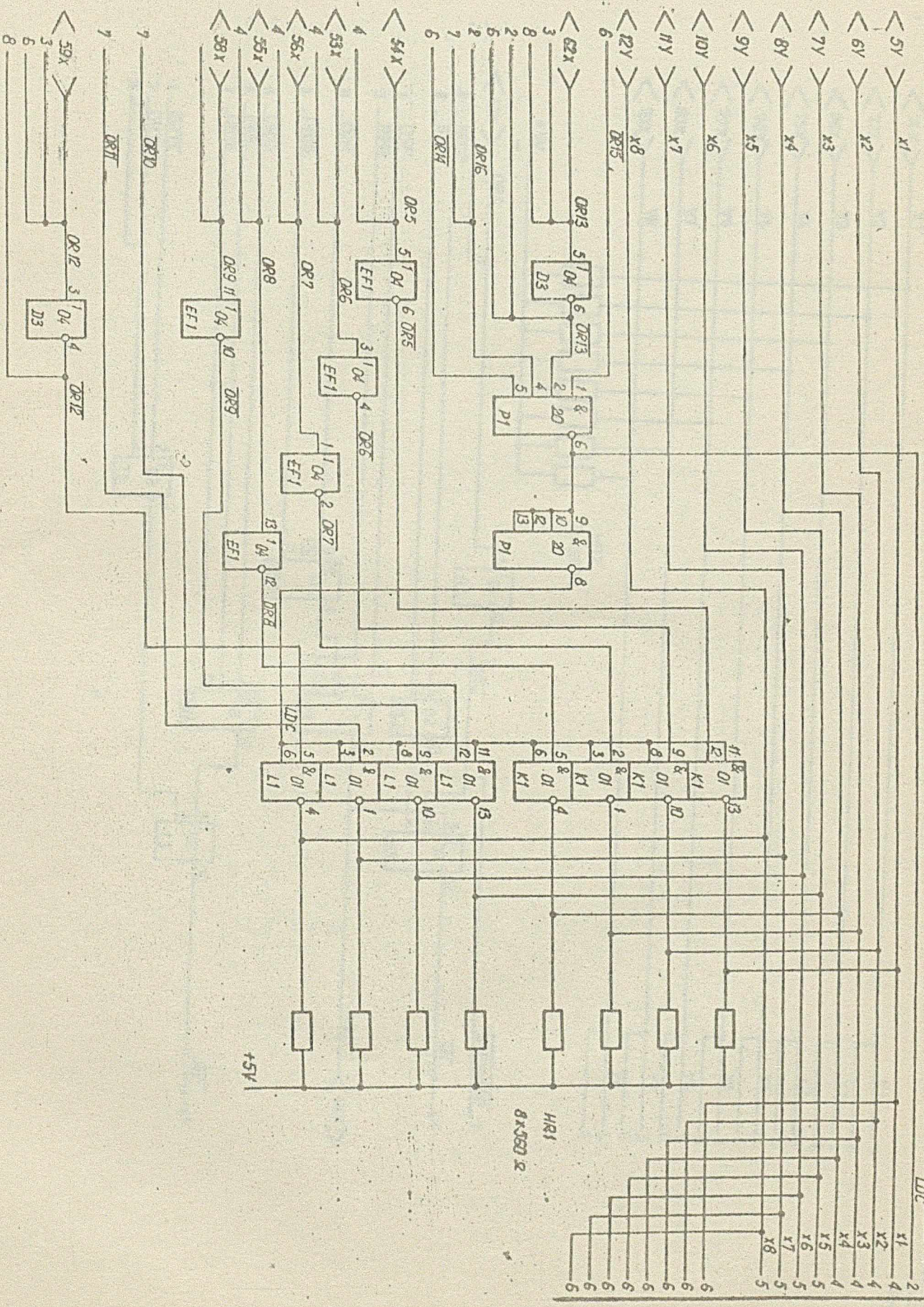

Trybun
 Płyta SP 45CPU
 schemat ideowy-ork. 1/9
 Nr. rys. 3-K-36783

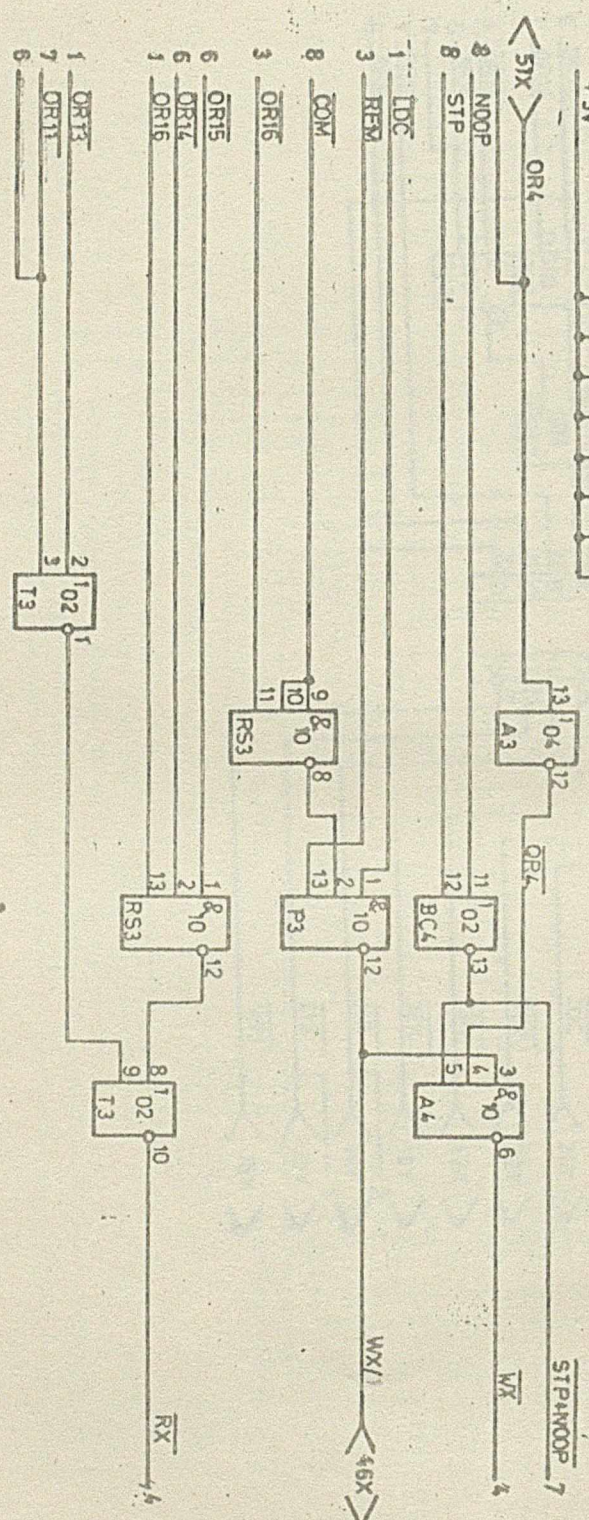
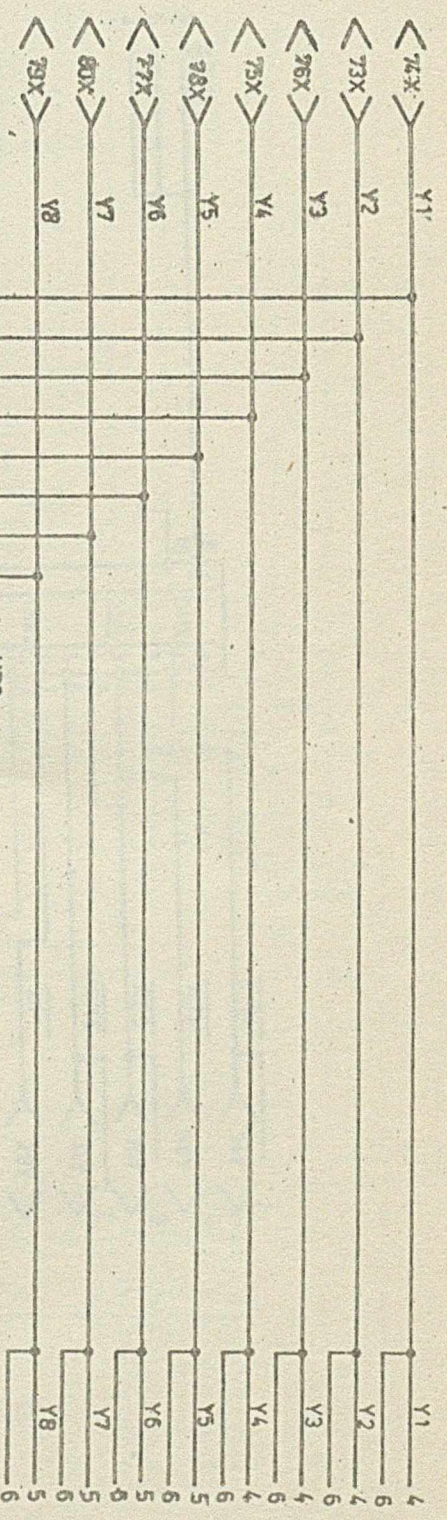

46/44
Tom II

Технічні схеми Kyta SP 45 CPU
схематично-ідеовий арк. 2/9
M79A
3-4-36783

125
125

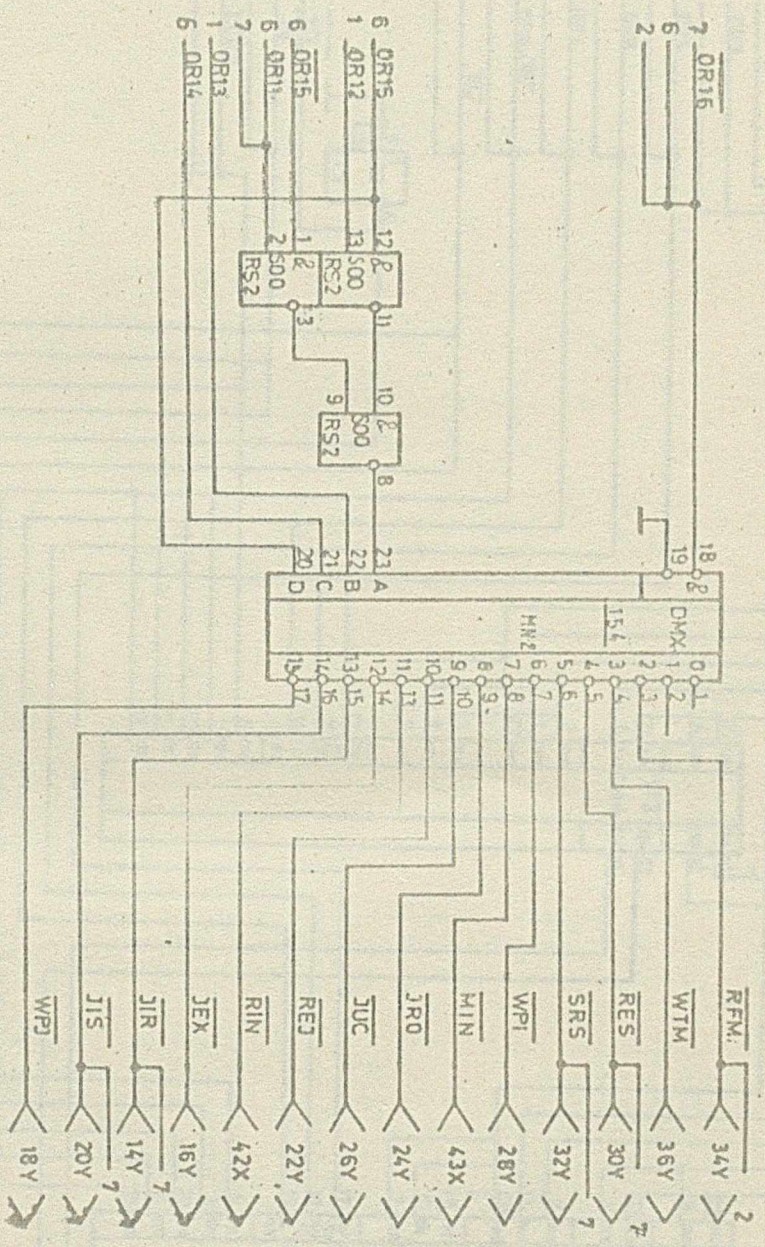

41/4
Peta SP45 CPU
Schemat idr wy-ark.3/9

3-L-36783

107
117

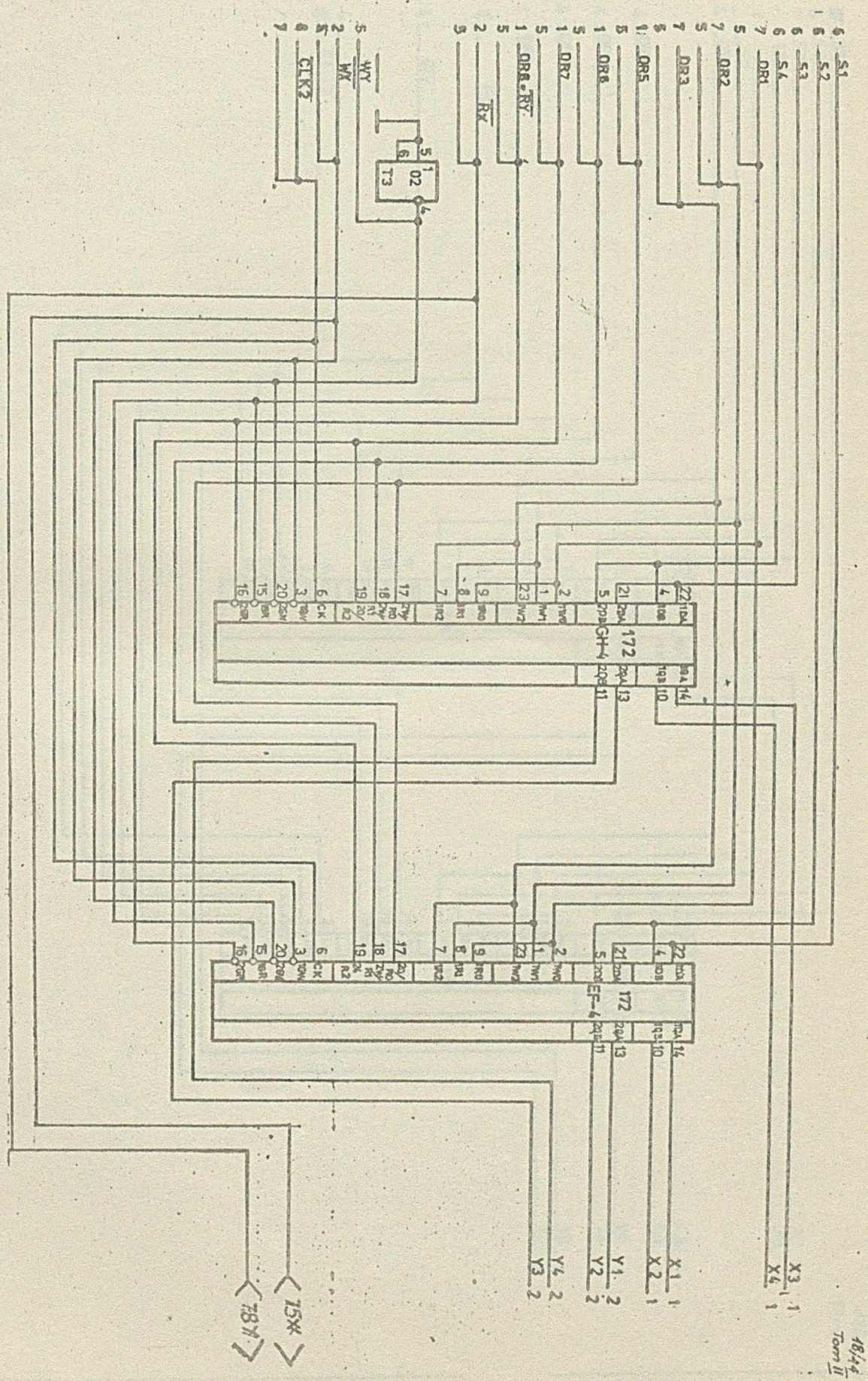

10/4
Tom II

Wydruk nr 5
Płyta SP 45 CPU
schemat ideowy-ark. 4/9
Nr rys. 3-L-36783

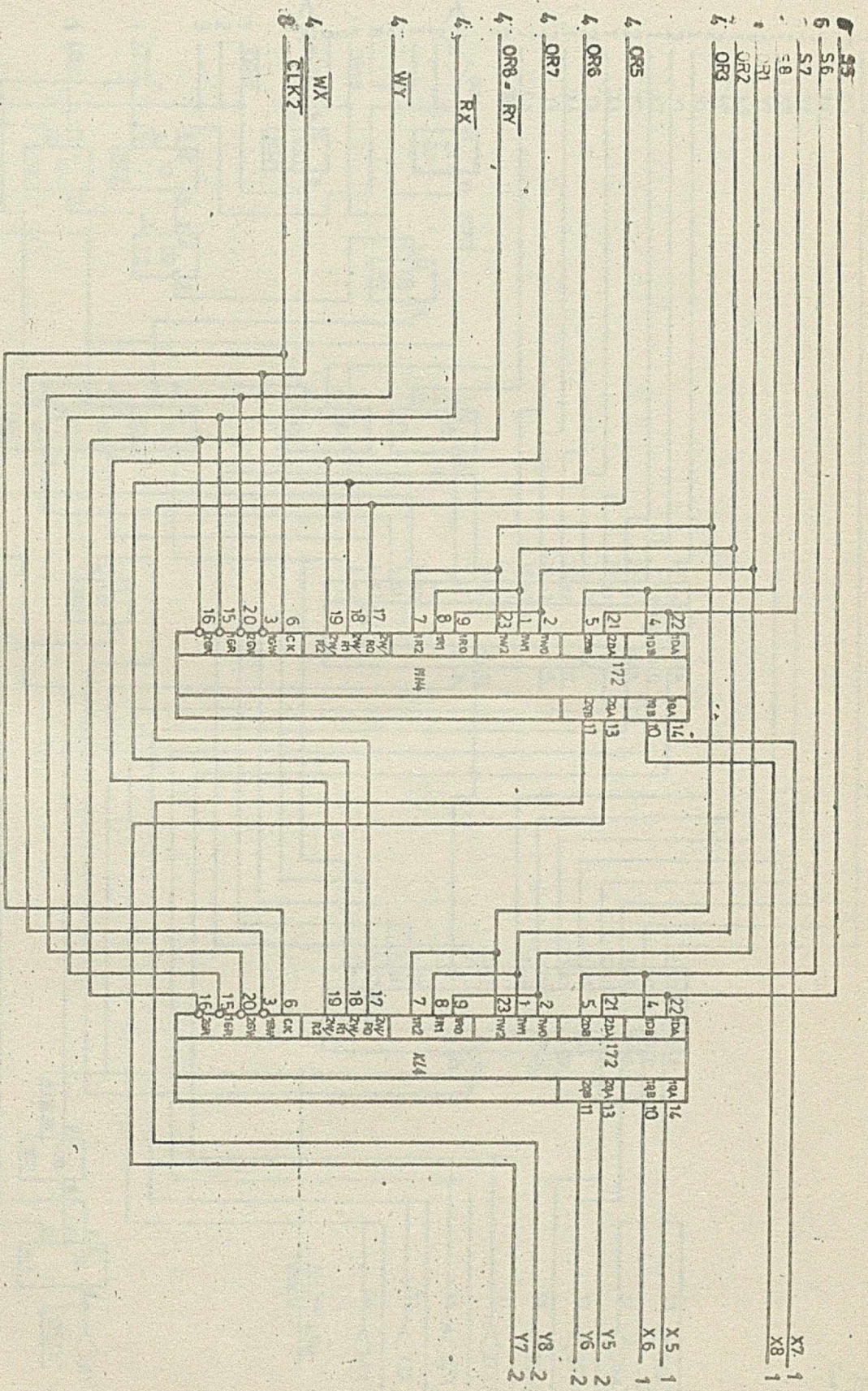

Tytuł rys.
 Płytkę SP 45 CPU
 schemat ideowy - ark. 5/9
 Nr rys.
 3-4-36783

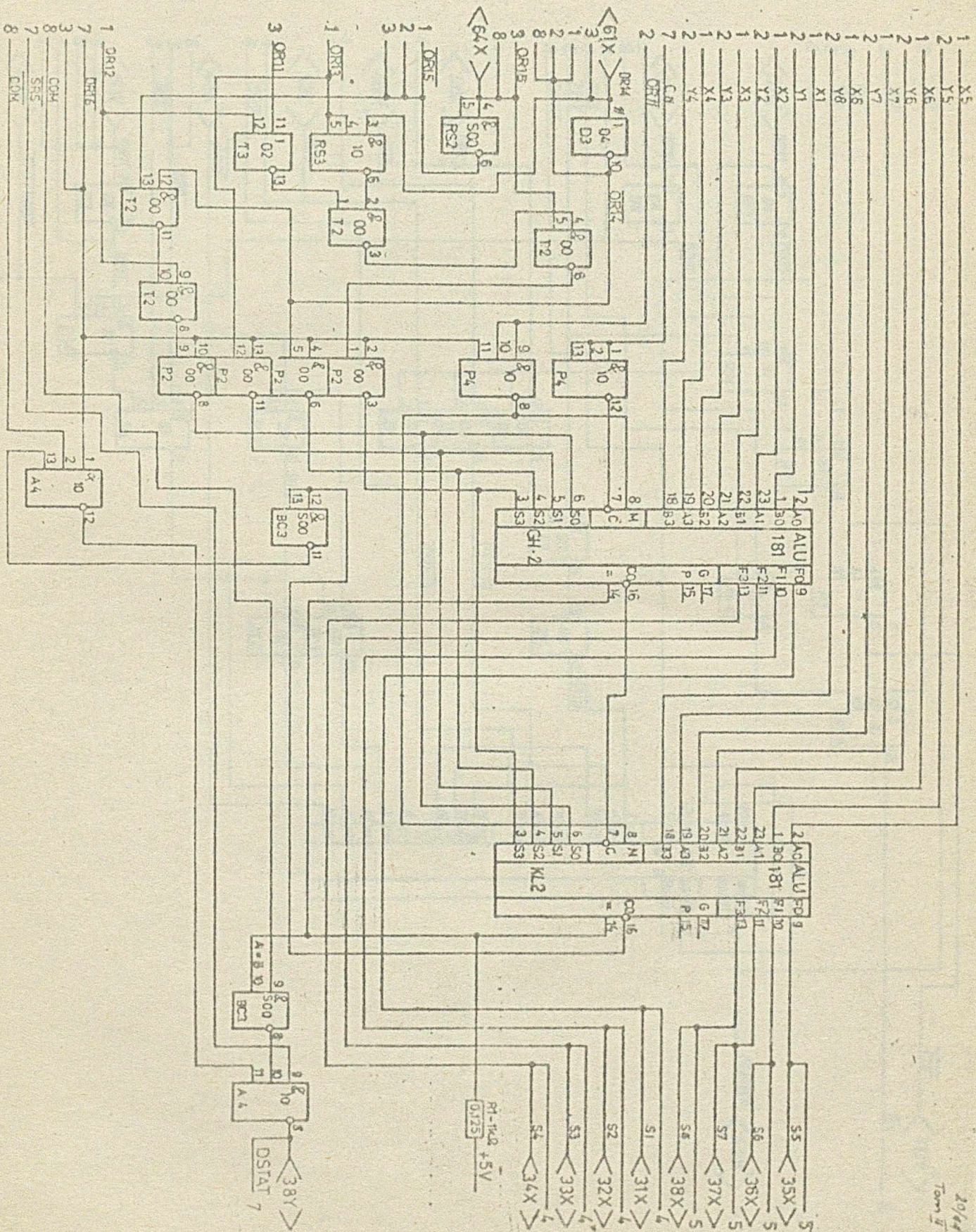

20/14
Tom II

Intel 8080 PNY16 SP 45 CPU
Ideowy - ork. 6/9

Wzrost
3-4-36783

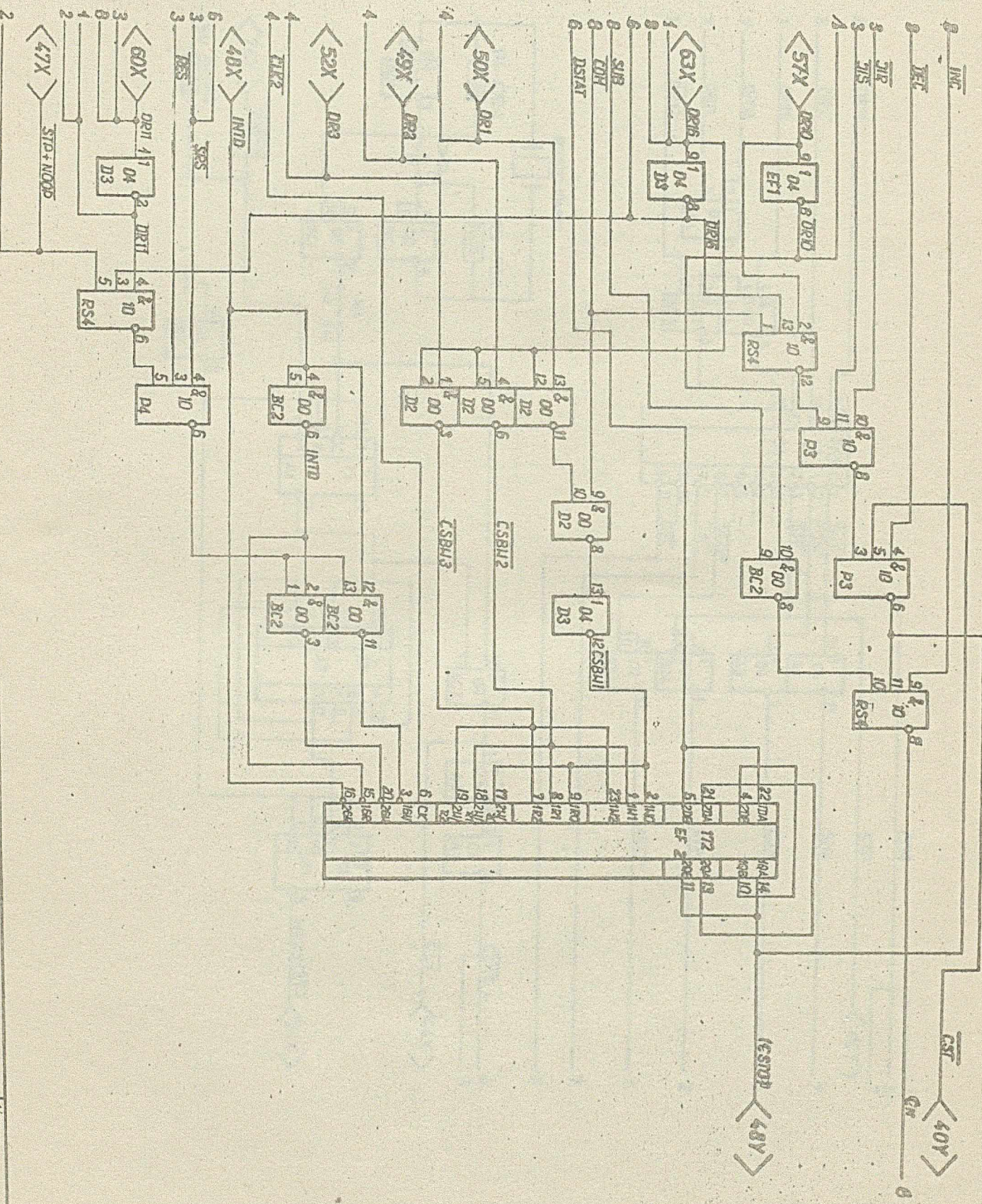

130
A30

Игитат. рус.
Pyтa SP 45 CPU
схемат. идею-арк. 719

Игитат. рус.
3-4-36783

244
Том II

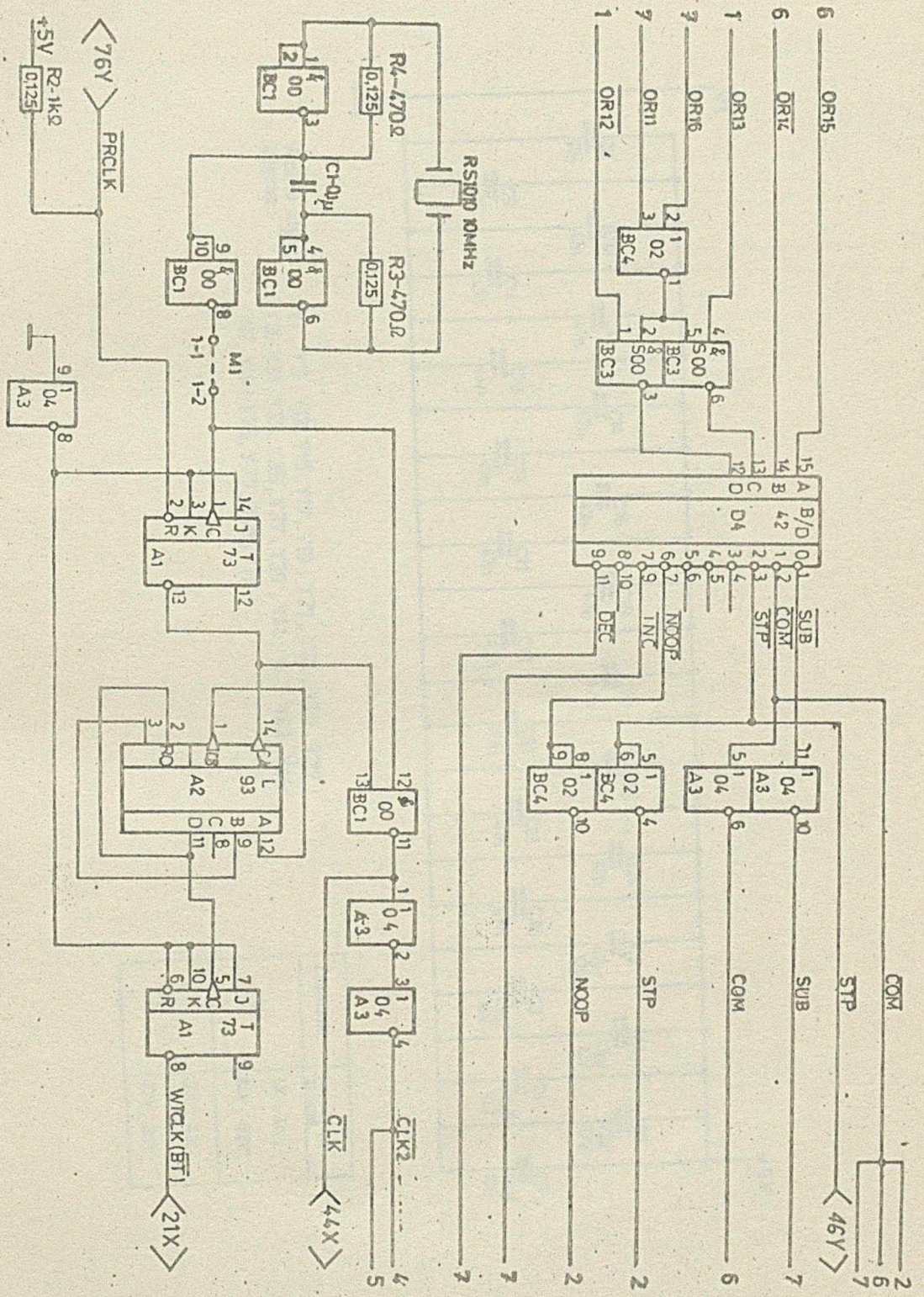

151
134

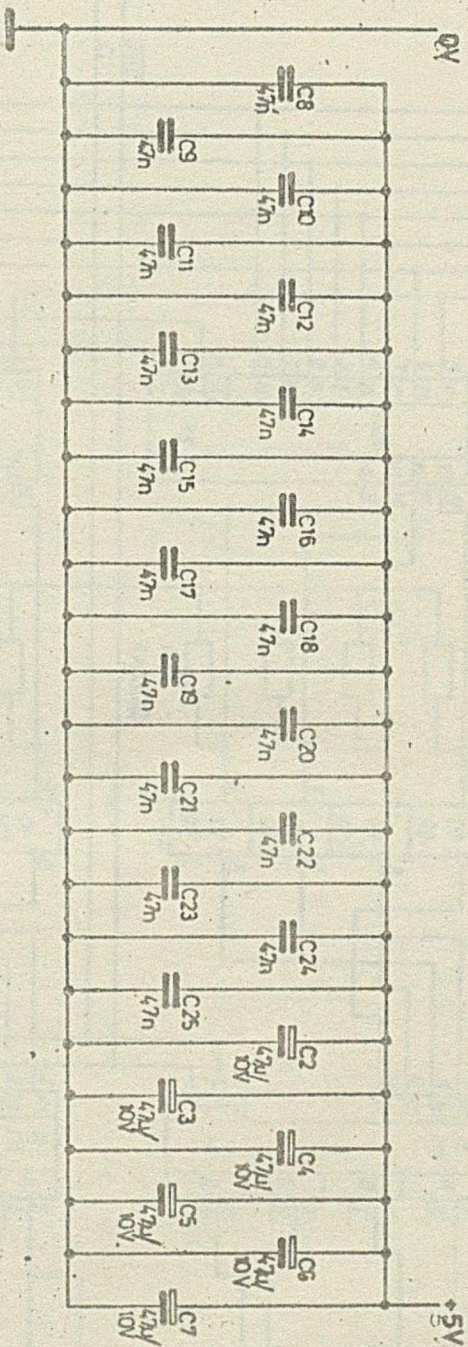

Wolne styki
złącza:

Y1, Y3, Y13, Y15, Y17, Y19, Y21, Y23, Y25, Y27
 Y29, Y31, Y33, Y35, Y37, Y39, Y41, Y42, Y43, Y45
 Y47, Y49 = Y75, Y77, Y78, Y79

Zasilanie	Nr. styku Złącza
+5V	1X; 3X; 81V; 83V;
0V	2X; 4X; 82V; 84V;

131
11.1.10

rytu rps
 Pyta SP 45 CPU
 schemat ideowy-ark. 9/r

N. rps
 3-L-36783

23/44
Tom II

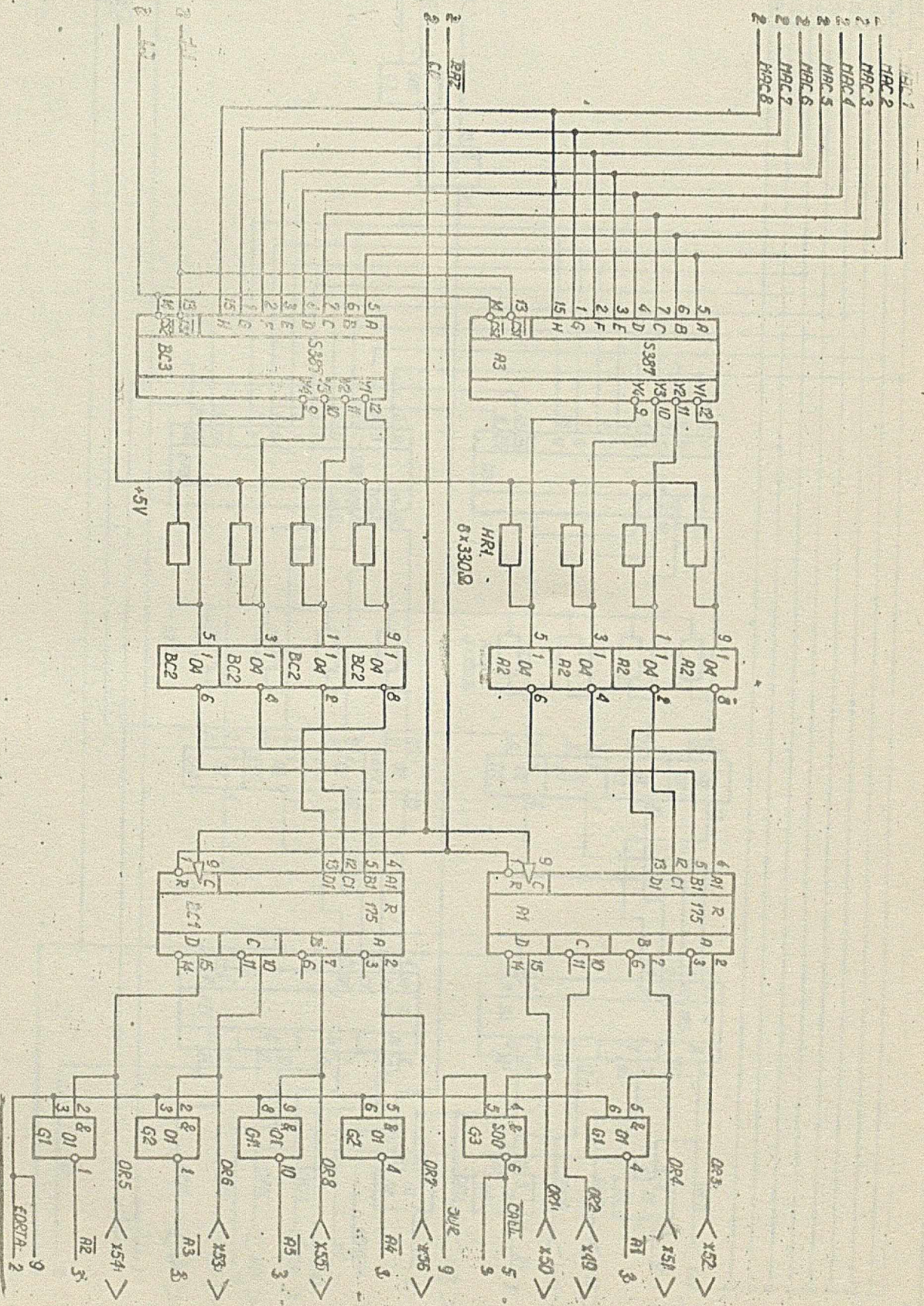

132
152

Pyta SP45 ROM/RAM
Schemat ideowy-ark. 1/11

3-L-36784

135
133

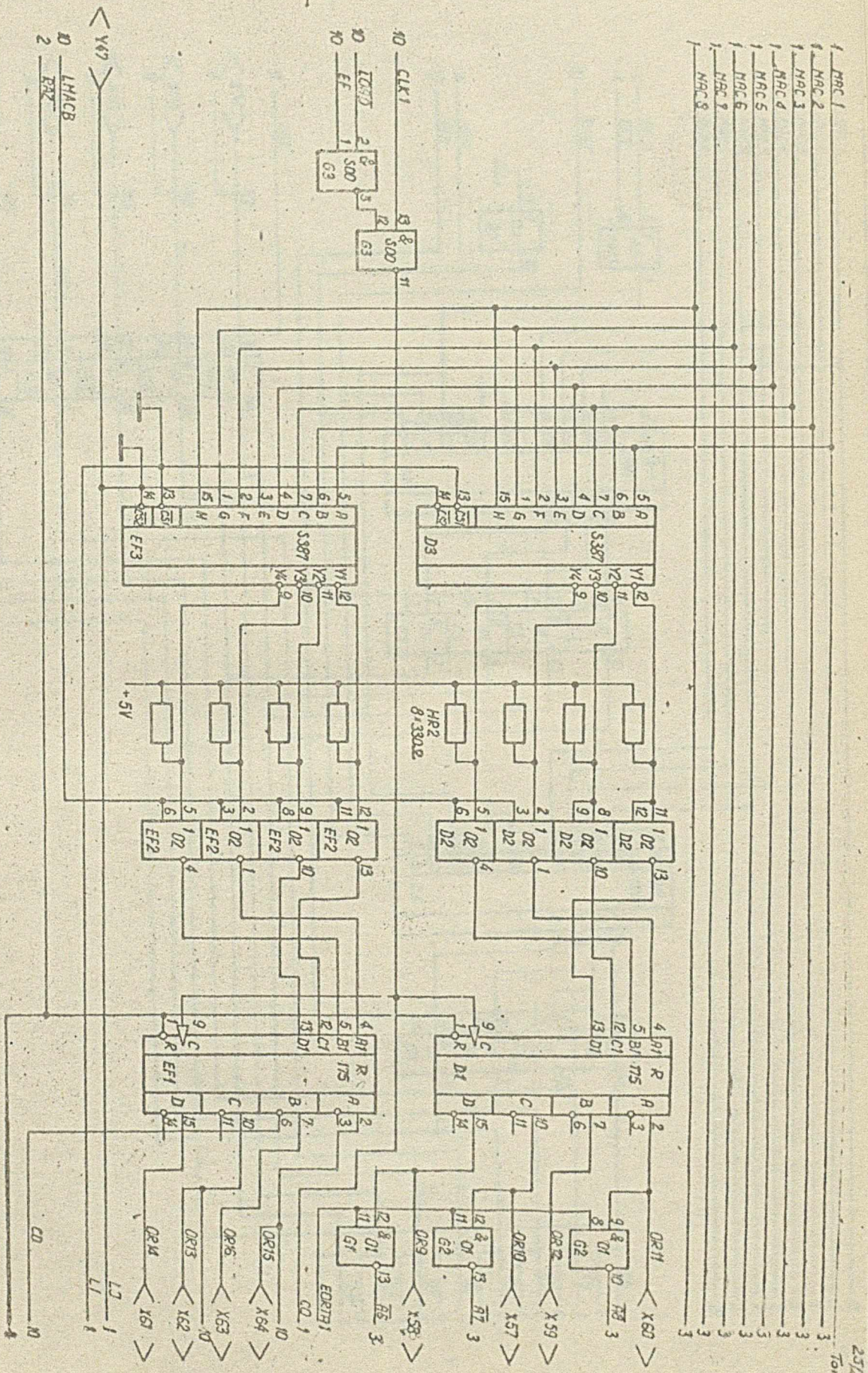

Typul rys. 135
Schemat ideowy - ark. 2/11
Nr rys. 3-L-36784

25/14
Tom II

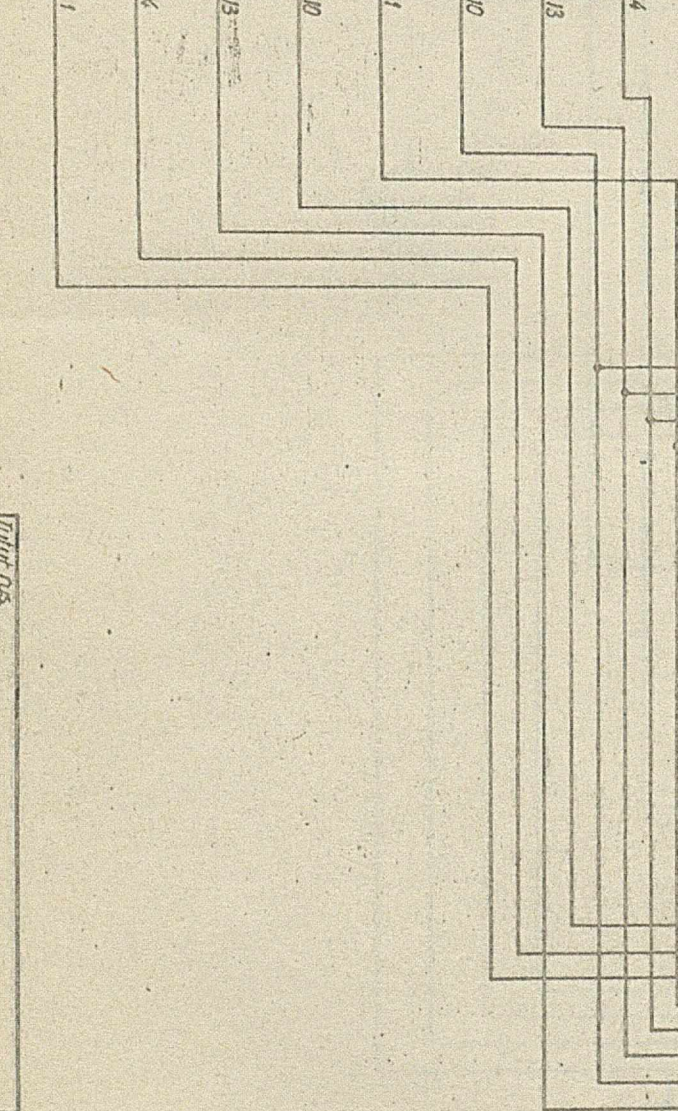
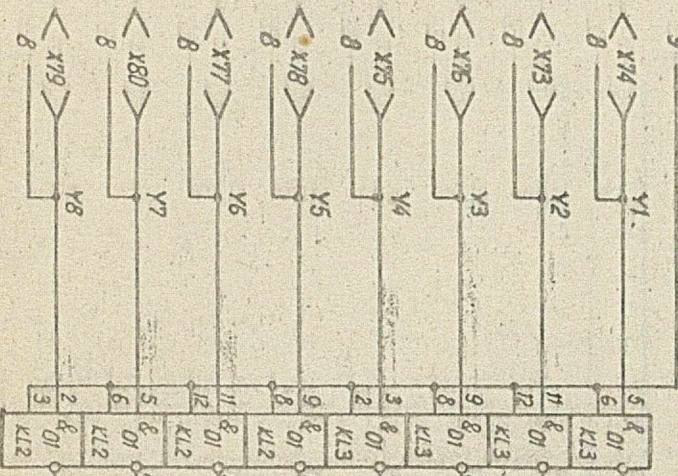
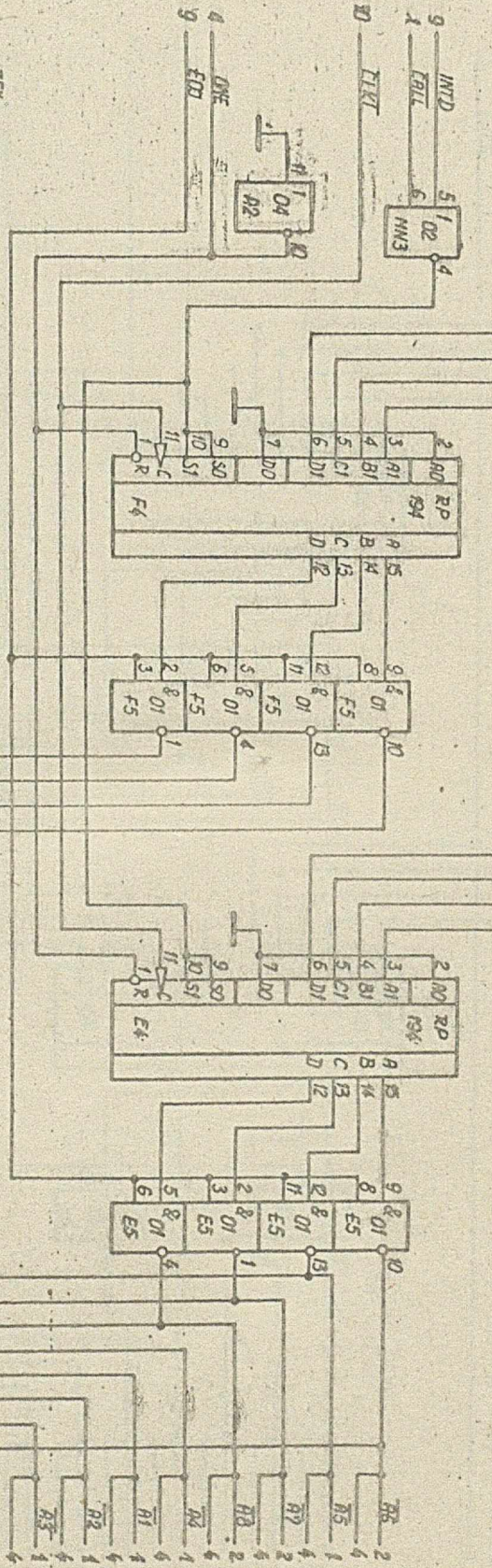
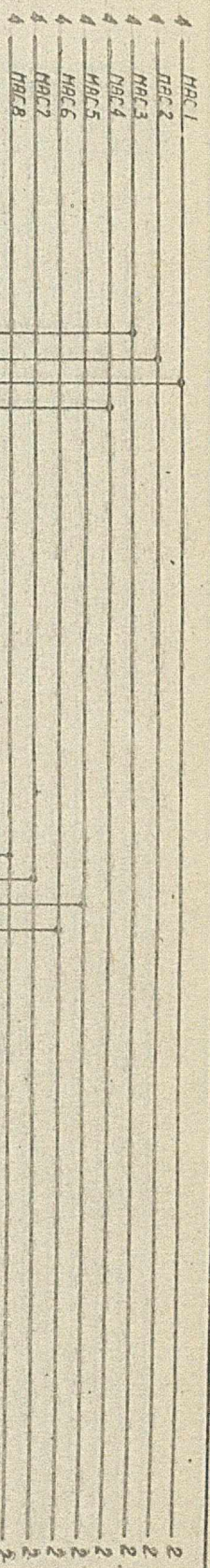

26/44
Tom II

Total nos
Phyto SP 45 ROM/ RAM
schemat ideowy-ark. 3/11

Wzrp
3-L-36784

5 MA01
 5 MA02
 5 MA03
 5 MA04
 5 MA05
 5 MA06
 5 MA07
 5 MA08

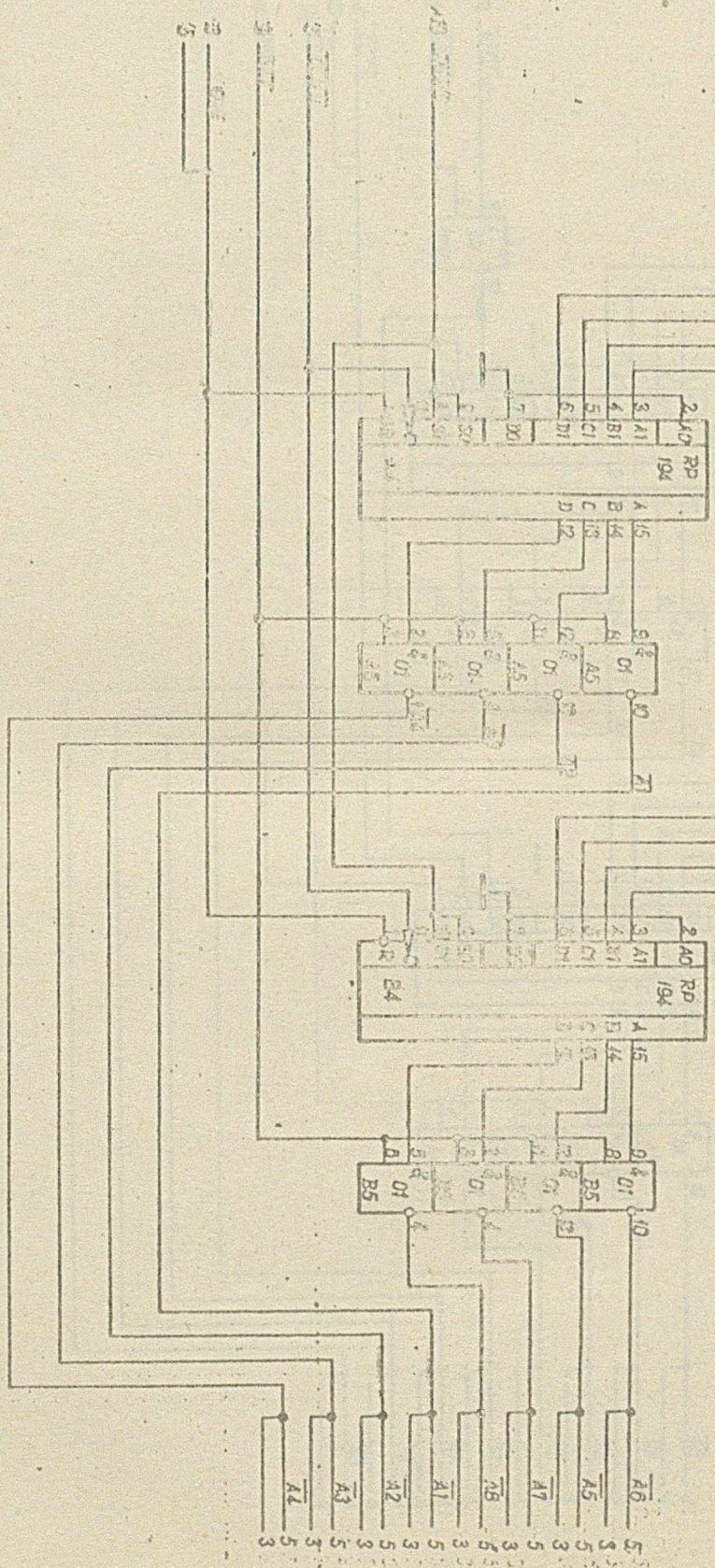

A0 5
 A1 5
 A2 5
 A3 5
 A4 5
 A5 5
 A6 5
 A7 5

27/4
 70-11

194 RP
 Płyta SP 45 ROM/RAM
 schemat ideowy - ark. 4/11

Nr rys.
 3-E-36784

135

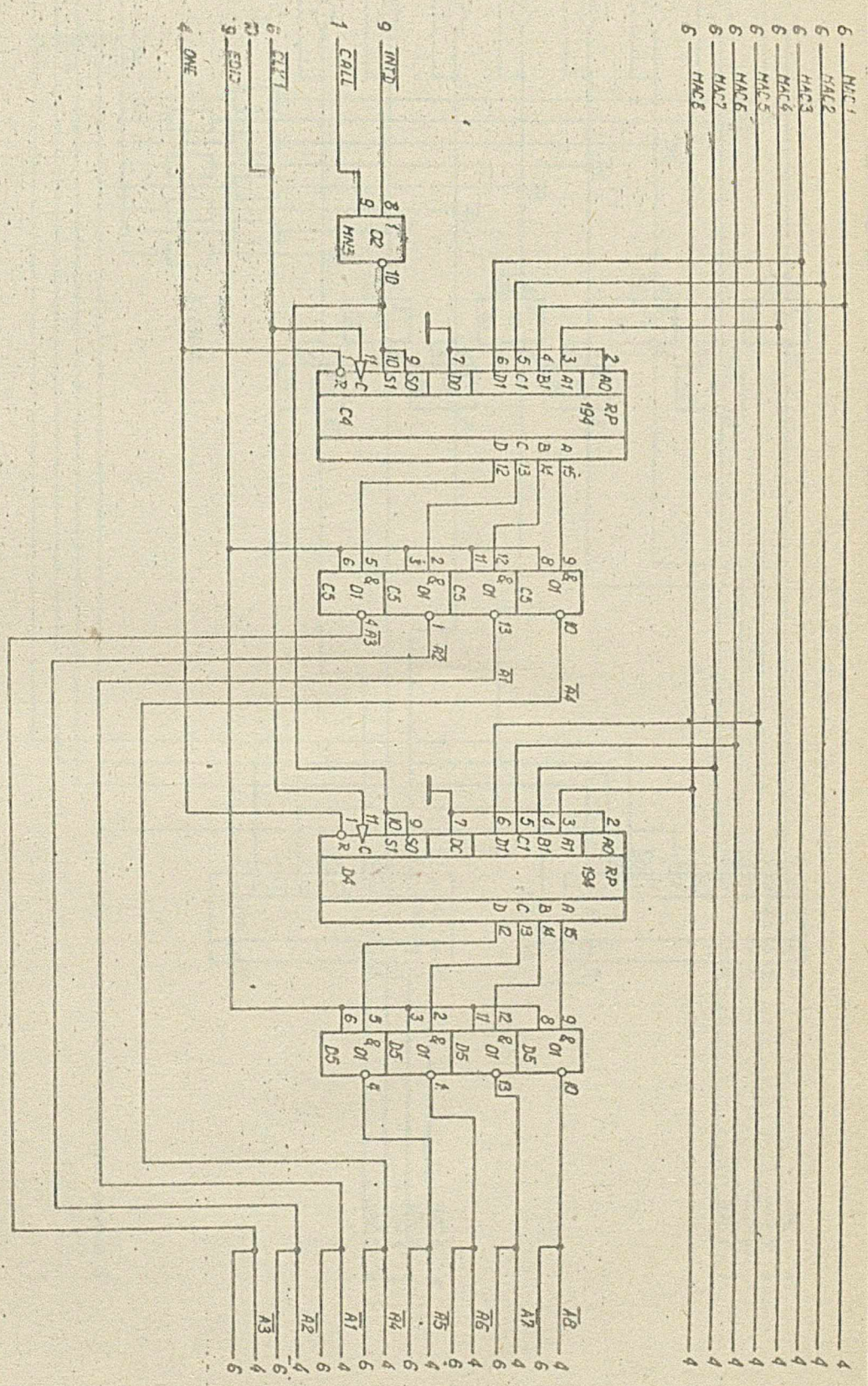

6 MAC1
6 MAC2
6 MAC3
6 MAC4
6 MAC5
6 MAC6
6 MAC7
6 MAC8

Titul rys. Płyta SP 45 ROM/RAM
schemat ideowy-ark. 5/11

№ rys. 3-L-36784

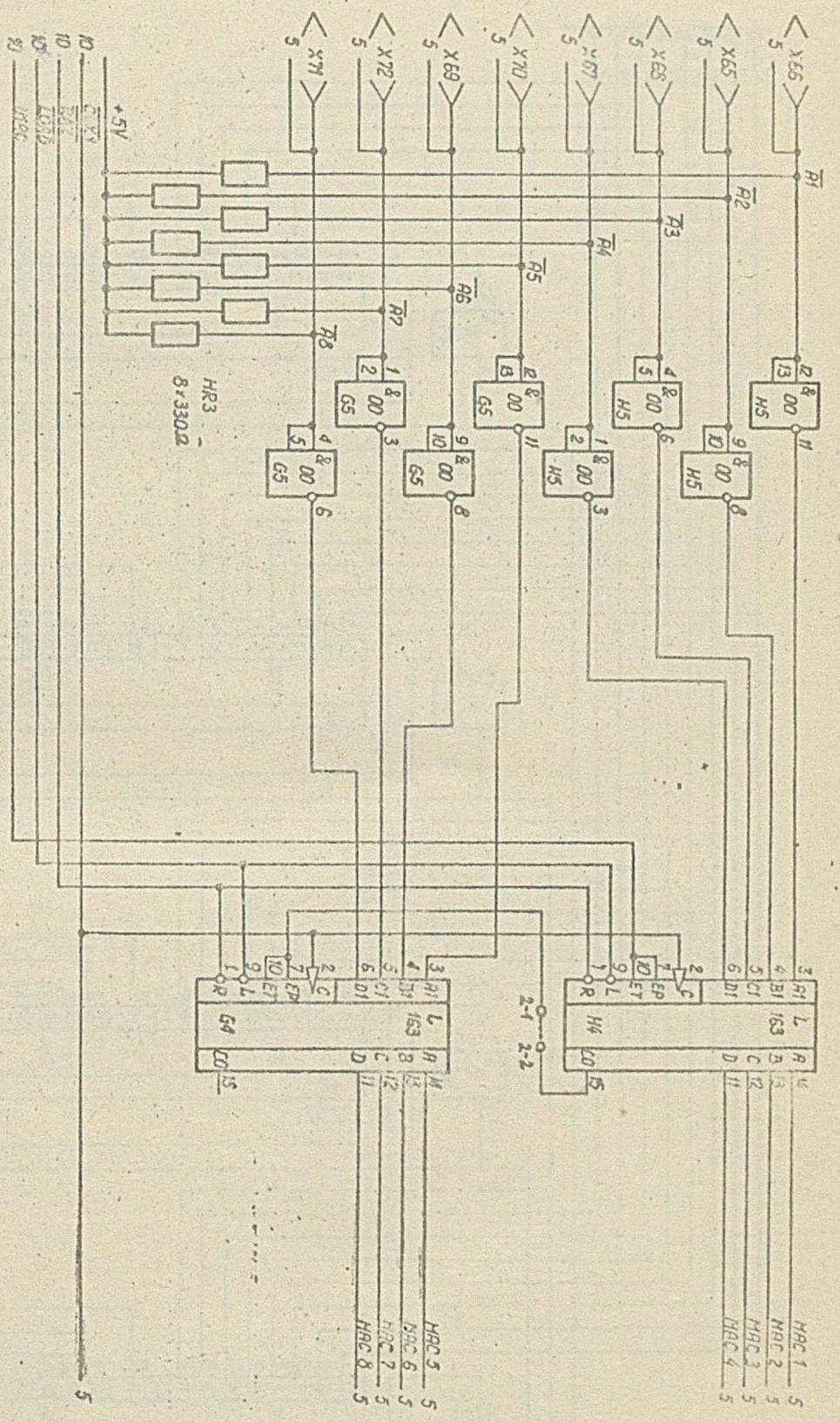

1977 r.a.
 Фото SP 45 ROM/RAM
 Схемат. идеовы-арк. 6/11
 3-Л-36784

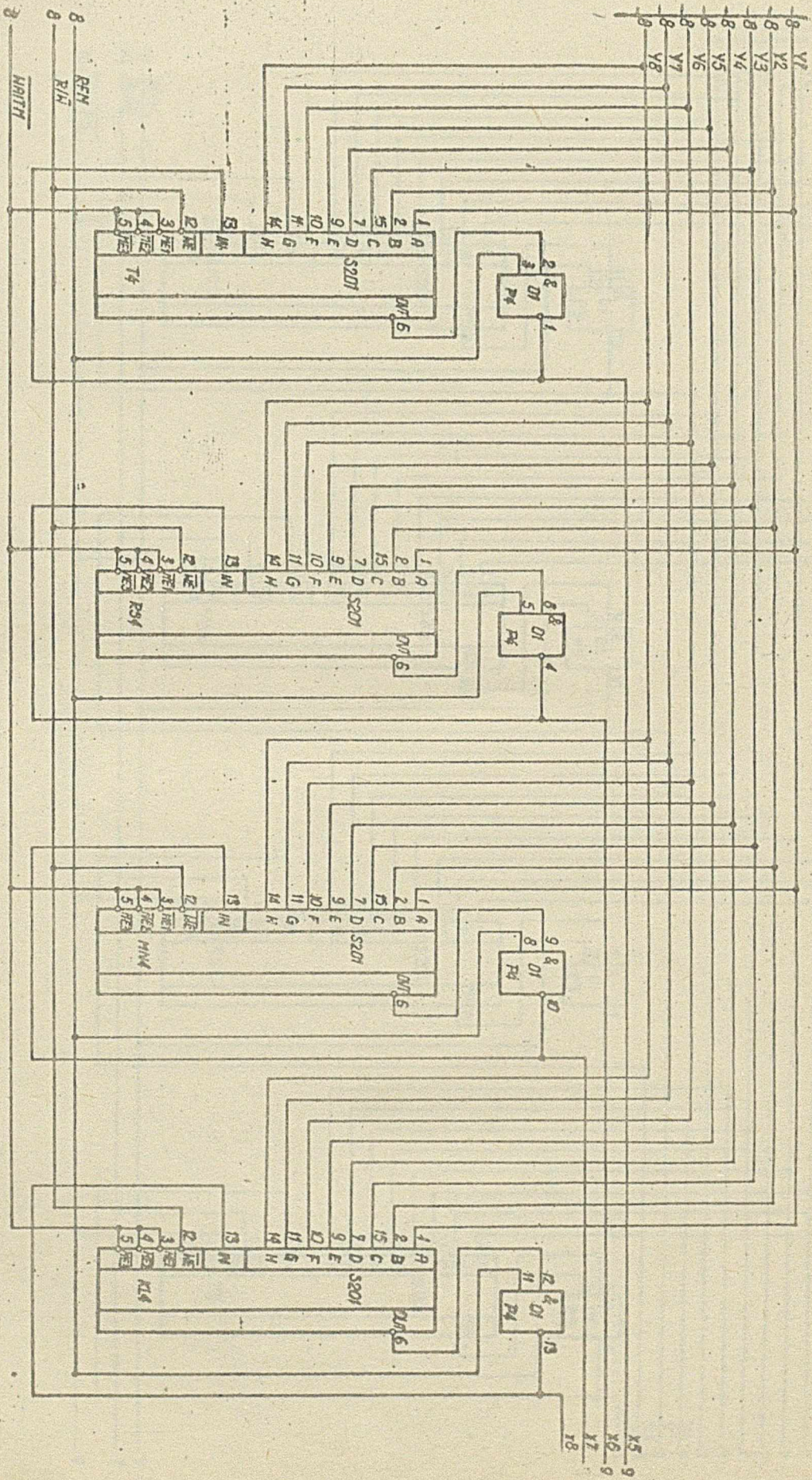

Tom II rgs
 Płyta SP 45 ROM / RAM
 Schemat ideowy - ork. 7/11

W rgs
 3-L-36784

Y1
Y2
Y3
Y4
Y5
Y6
Y7
Ye

10 R/W
10 R/W
10 WRITM

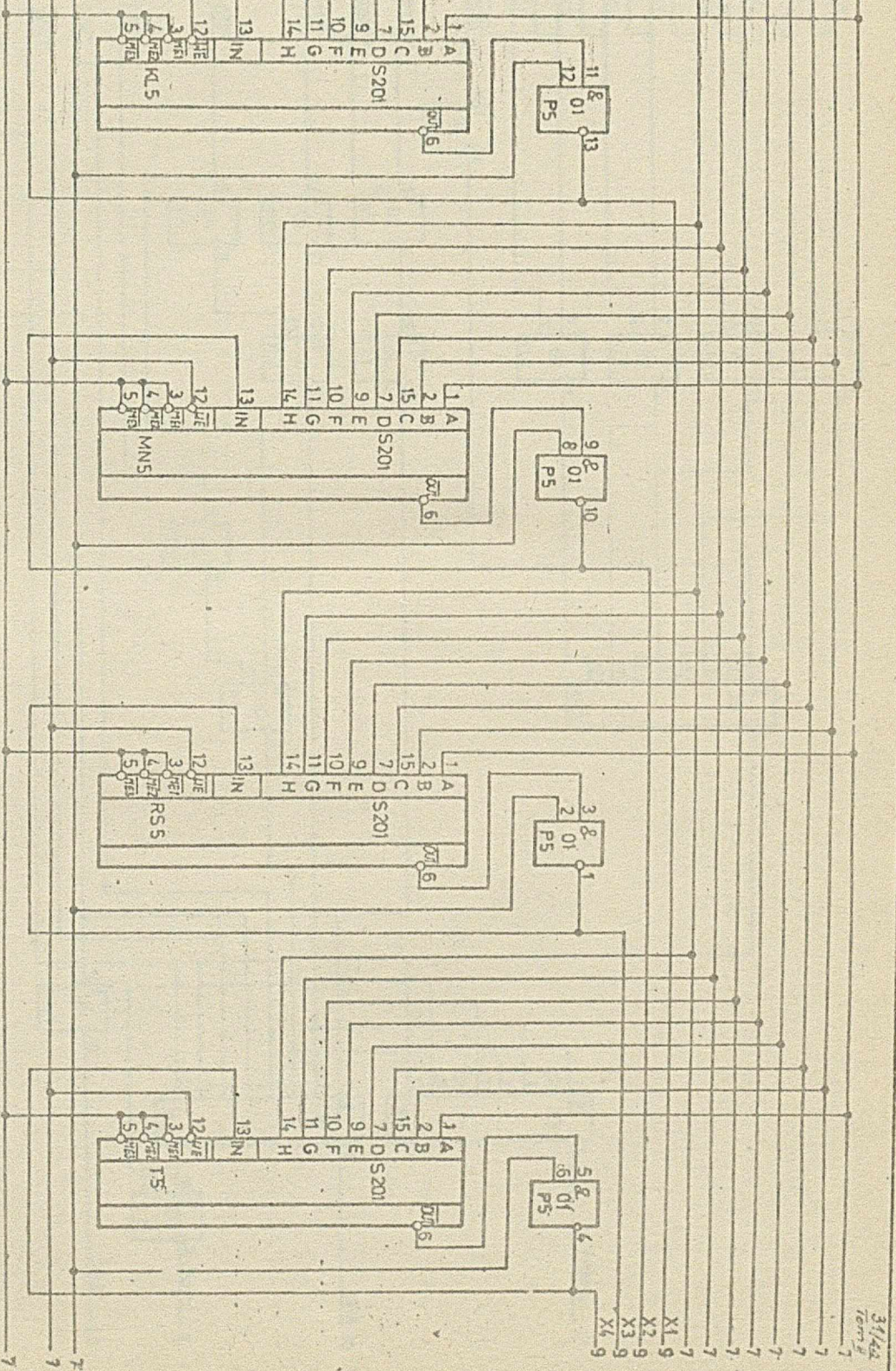

3/144
70m13
7

Typut. Ds. Pyta SP 45 ROM/RAM
schemat ideowy - ark. 8/11

Nr PMS
3-E-36784

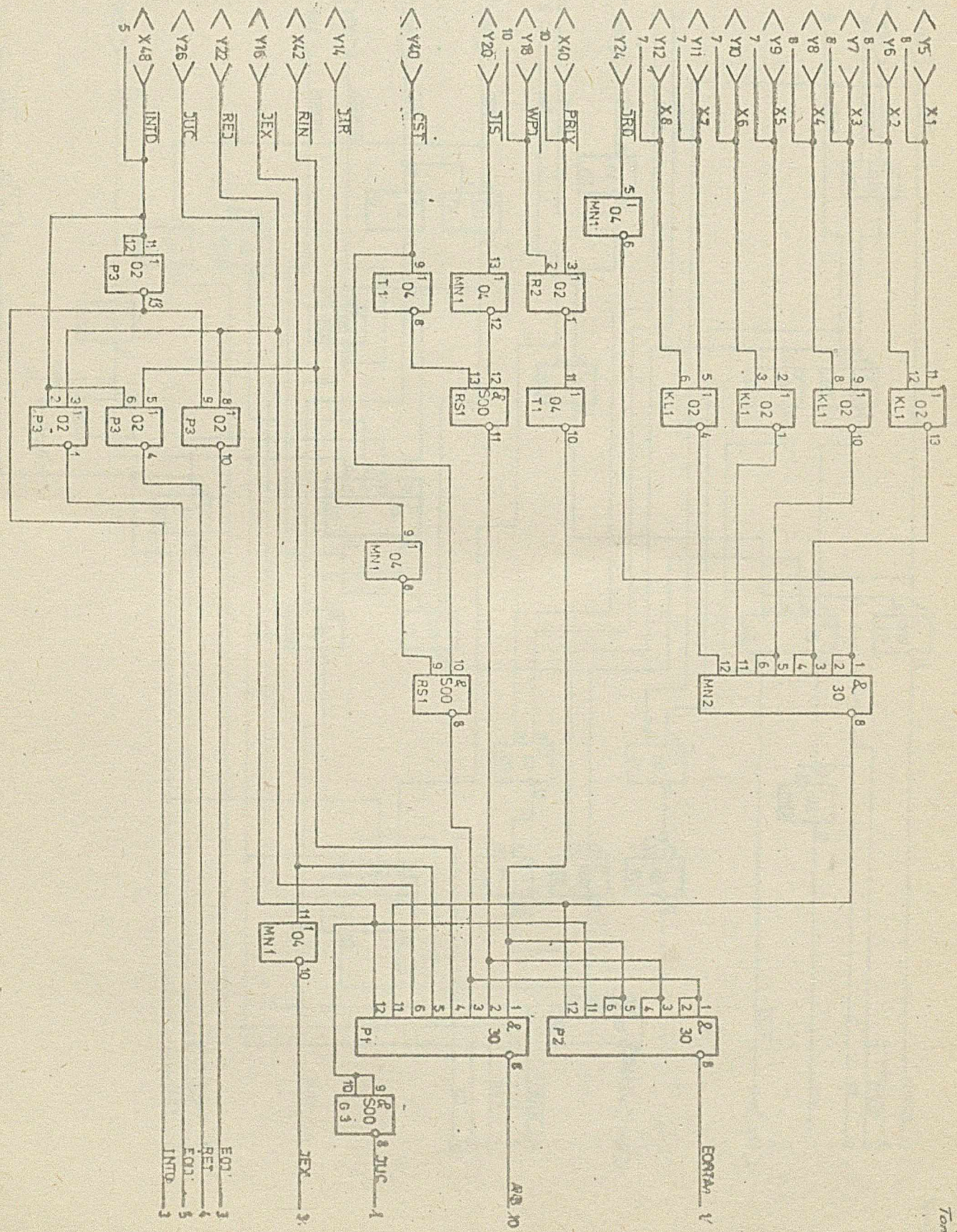

Phytolite
Phyto SP 45 ROM/RAM
schemat ideowy - ark 9/11
3-4-36784

40
A40

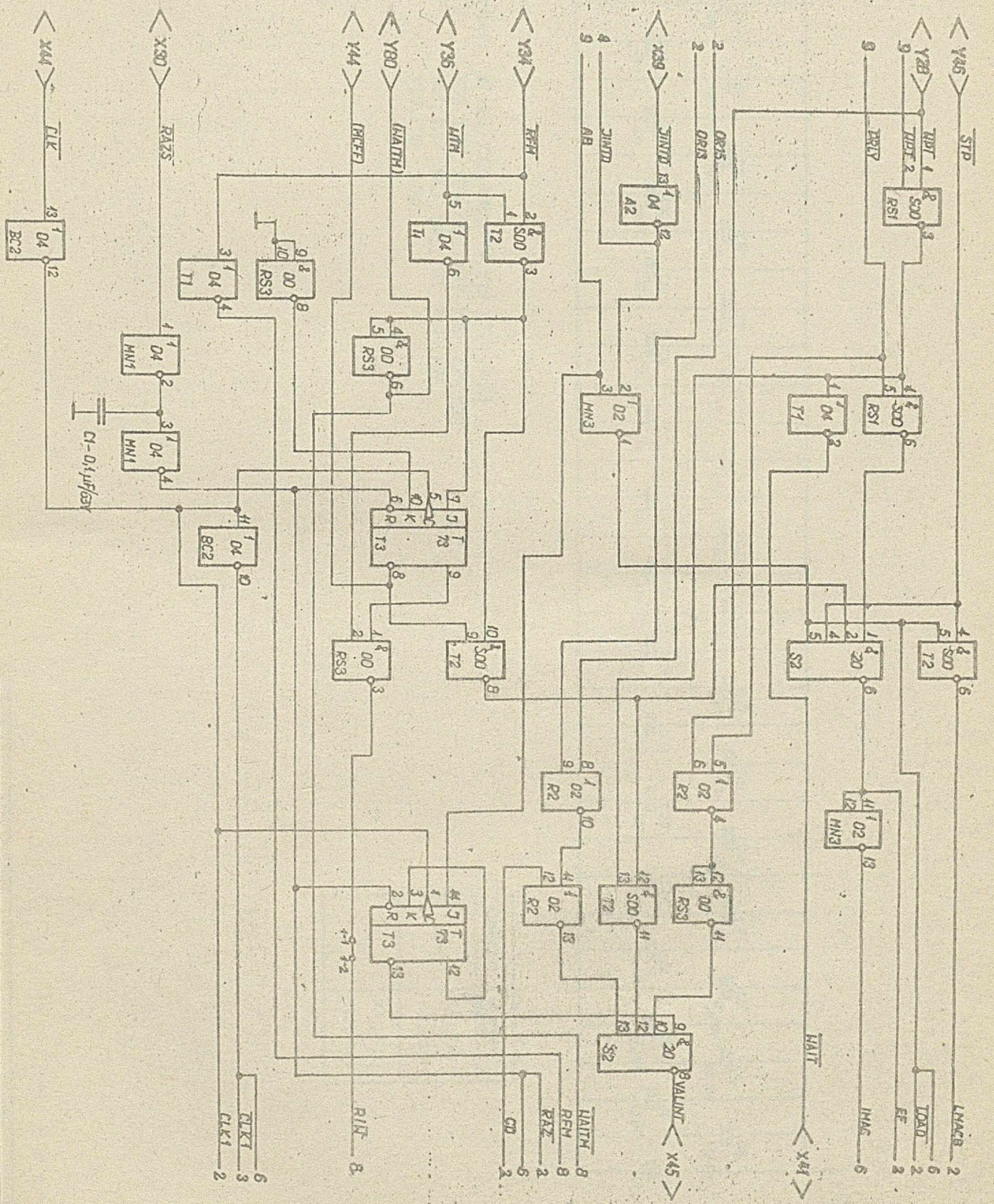

Intel
SP45 ROM/RAM
Schemat ideowy-ark.10/11

nr rys
3-L-36784

141
141

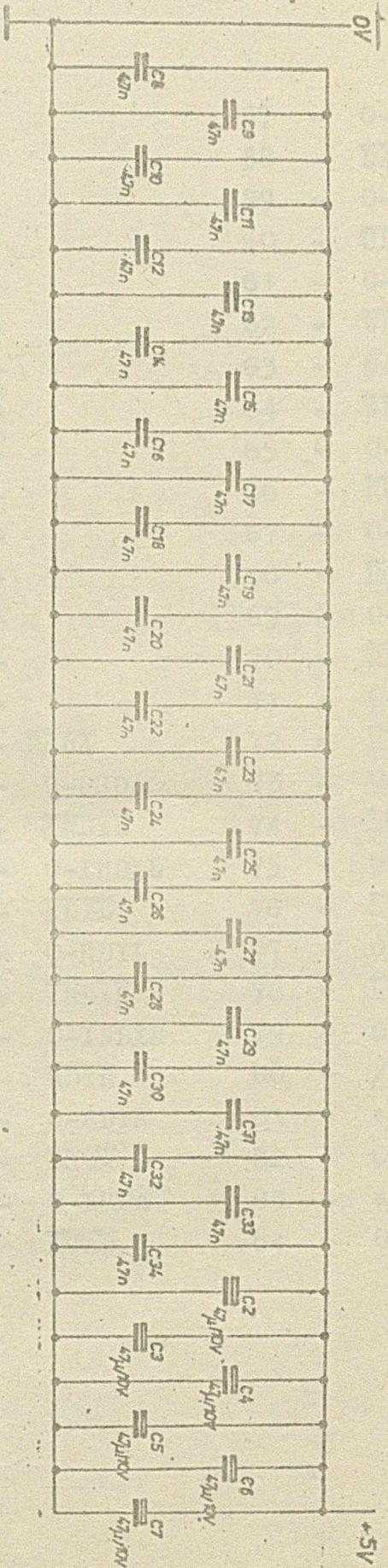

Ważne styki
złącza:

Y1, Y3, Y13, Y15, Y17, Y19, Y21, Y23
 Y25, Y27, Y29, Y31, Y33, Y35, Y37, Y39
 Y41, Y42, Y43, Y45, Y47, Y49 - Y75
 Y77, Y78, Y79

Zasilanie	Na styku Złącza
+5V	X1; X3; Y81; Y83;
0V	X2; X4; Y82; Y84;

Płyta SP45 SEL - wykaz sygnałów złącza X

1 -		29 -		57 -	O-LOAD
2 -	OV	30 -		58 -	DISKR
3 -		31 -		59 -	O-DISKR
4 -	OV	32 -		60 -	CDATA
5 -		33 -		61 -	O-CDATA
6 -		34 -		62 -	WRTD
7 -		35 -		63 -	O-WRTD
8 -		36 -		64 -	WRITEN
9 -		37 -		65 -	O-WRTEN
10 -		38 -		66 -	RUN
11 -		39 -		67 -	O-RUN
12 -		40 -		68 -	RCLK
13 -		41 -		69 -	O-RCLK
14 -		42 -		70 -	RDATA
15 -		43 -		71 -	O-RDATA
16 -		44 -	RSDA	72 -	HOME
17 -		45 -	O-RSDA	73 -	O-HOME
18 -		46 -	INDXL	74 -	STPOUT
19 -		47 -	O-INDXL	75 -	O-STPOUT
20 -		48 -	RDYL	76 -	STPIN
21 -		49 -	O-RDYL	77 -	O-STPIN
22 -		50 -	INDXR	78 -	EG
23 -		51 -	O-INDXR	79 -	O-EG
24 -		52 -	RDYR	80 -	/OV/
25 -		53 -	O-RDYR	81 -	+5V
26 -		54 -	LSDA	82 -	OV
27 -		55 -	O-LSDA	83 -	+5V
28 -		56 -	LOAD	84 -	OV

36/44
Tom II

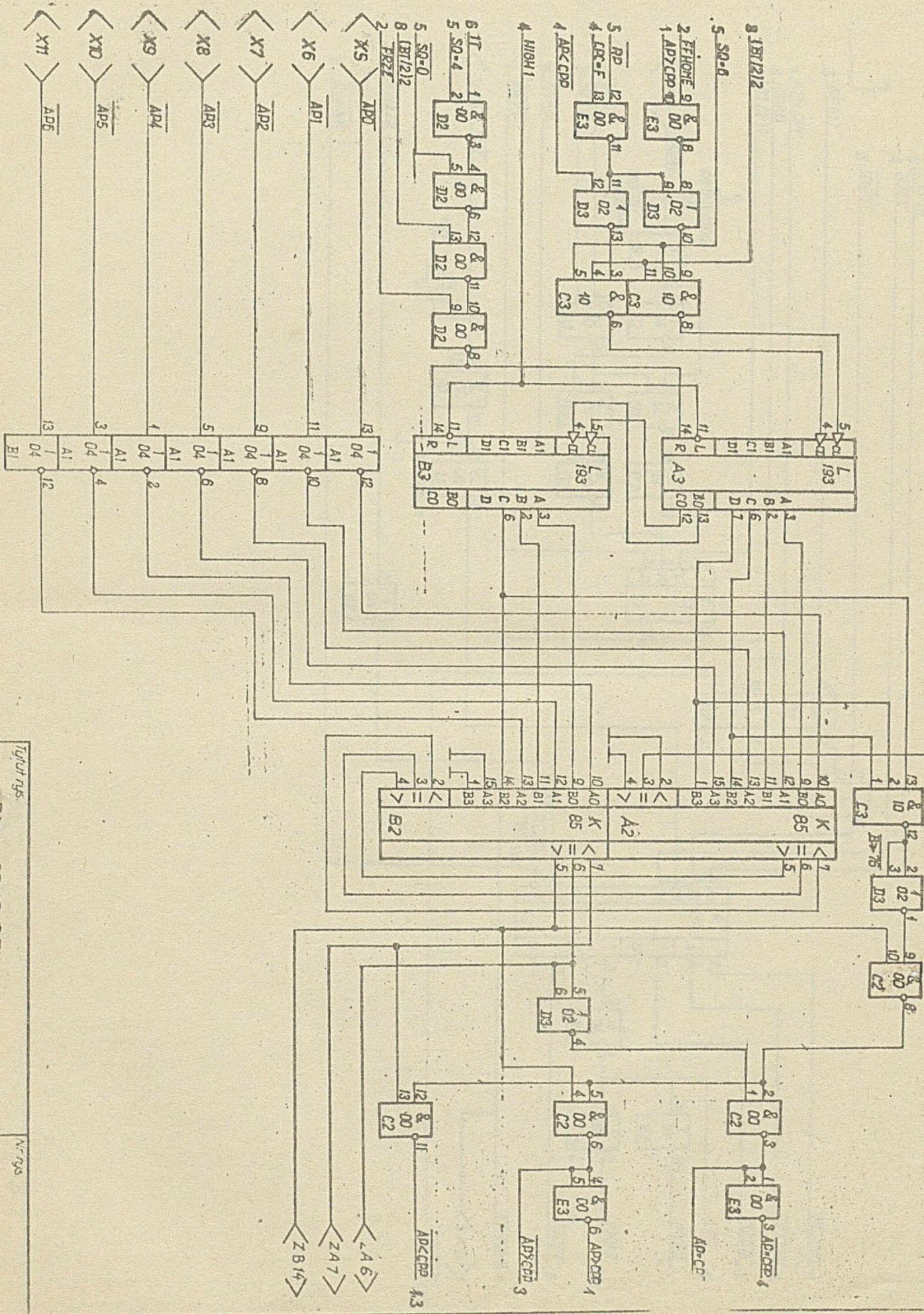

Typu rgs
 Płyta SP 45 SEL
 schemat ideowy-ark. 1/9
 Nr rgs
 3-L-36782

144

144

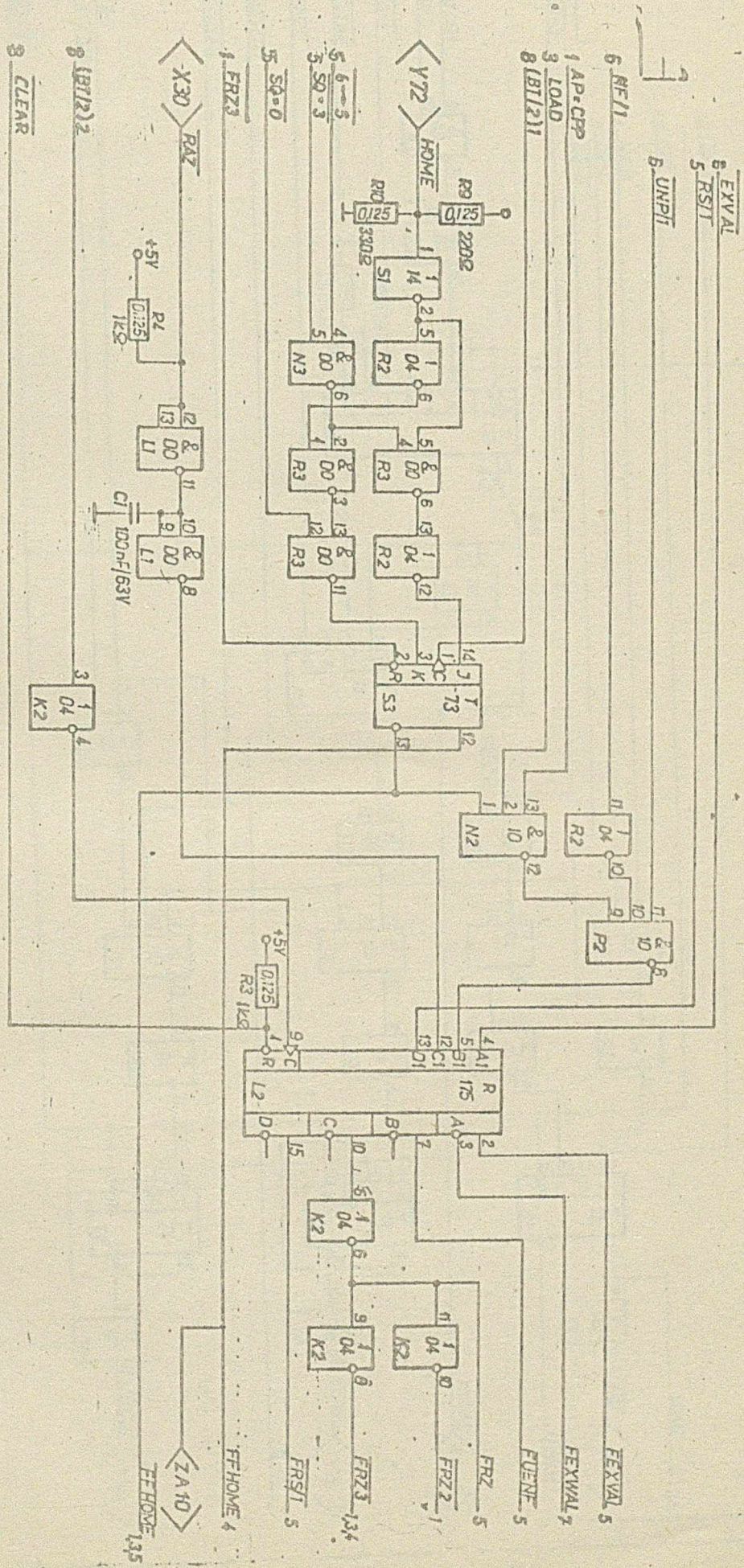

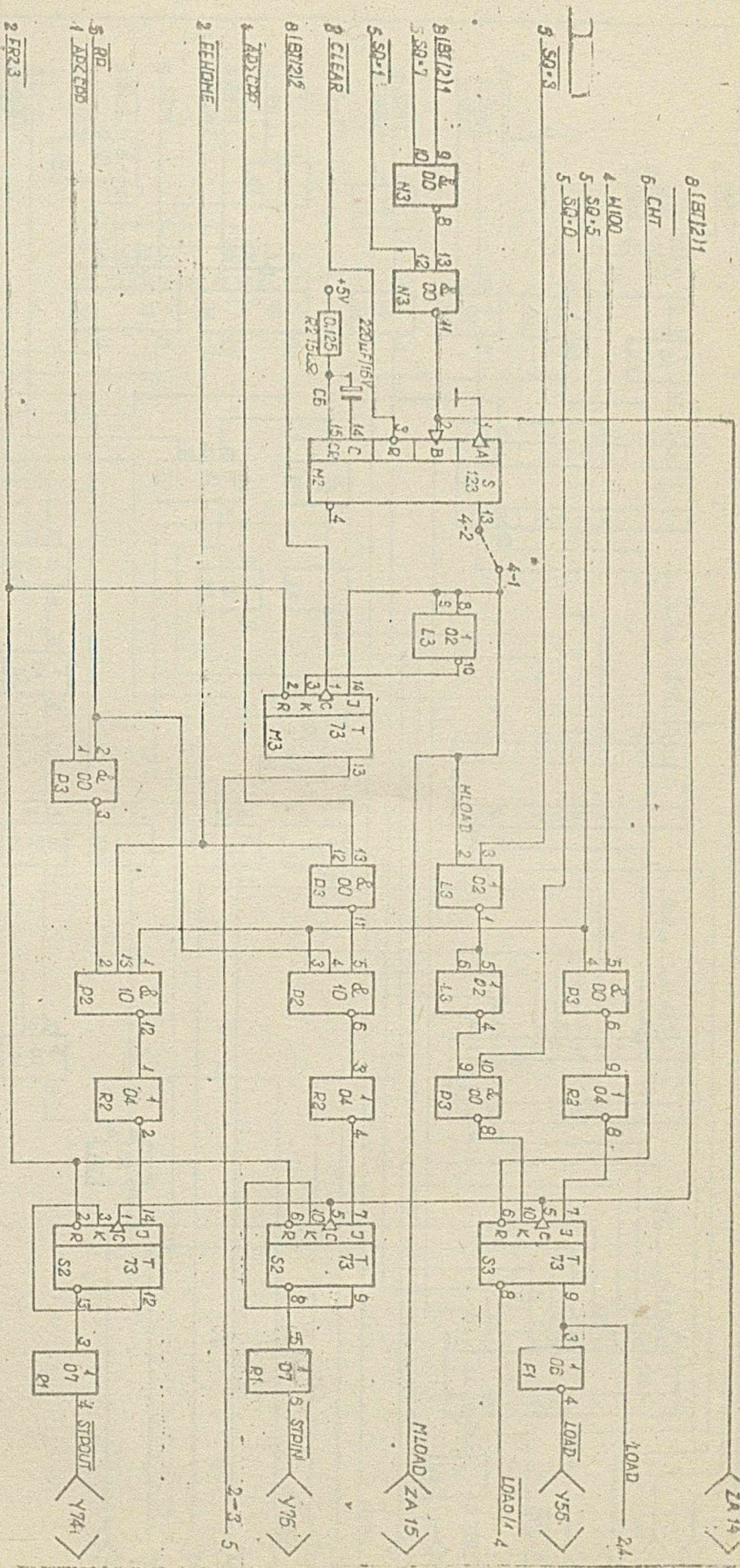

146

146

Pyta SP45 SEL
schemat ideowy-ark. 3/9

3-2-36782

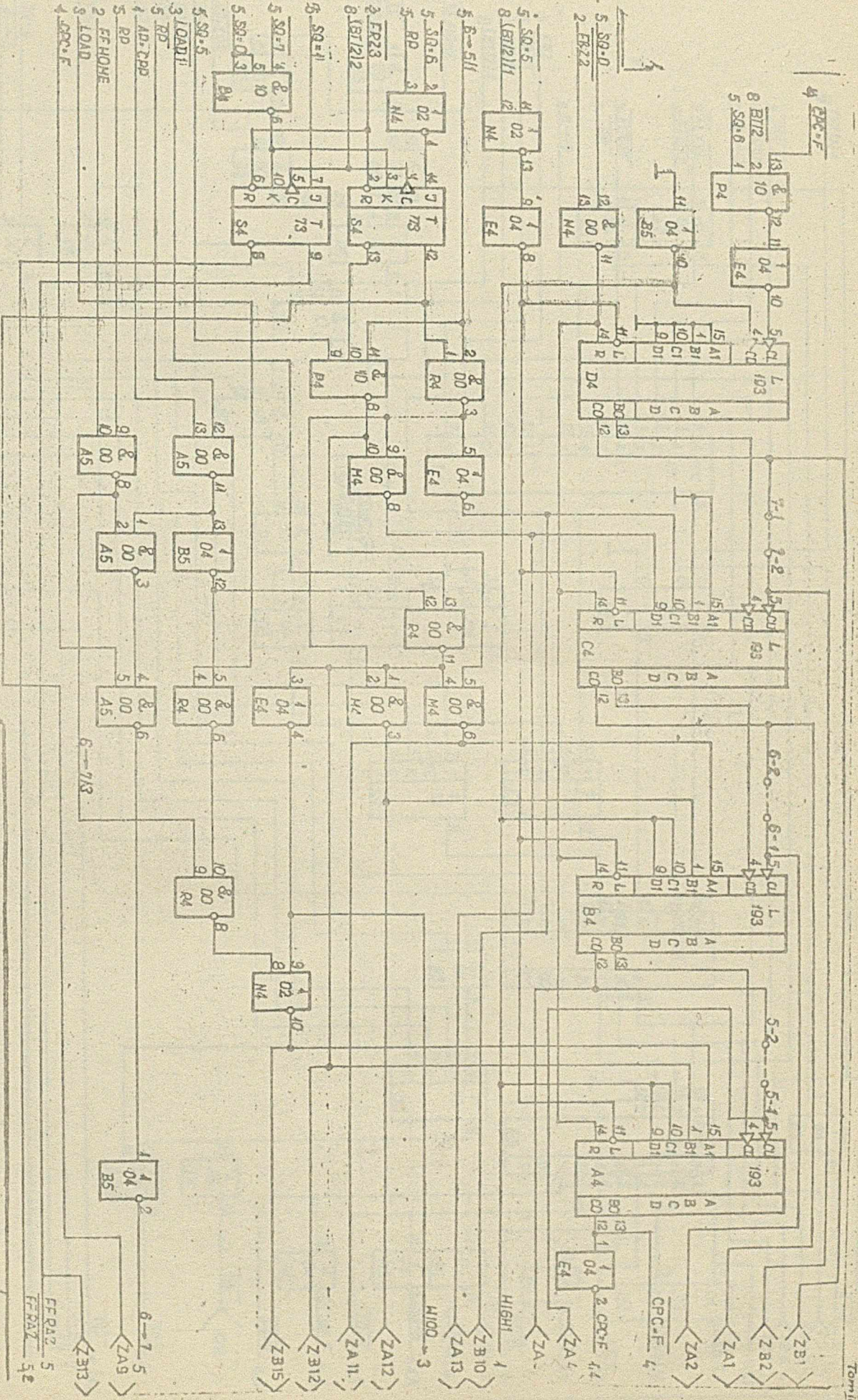

Typul rys. 39/41
Tom II

Pyta SP 45 SEL
schemat ideowy - ark. 4/9

Nr rys. 3-6-36782

148
148

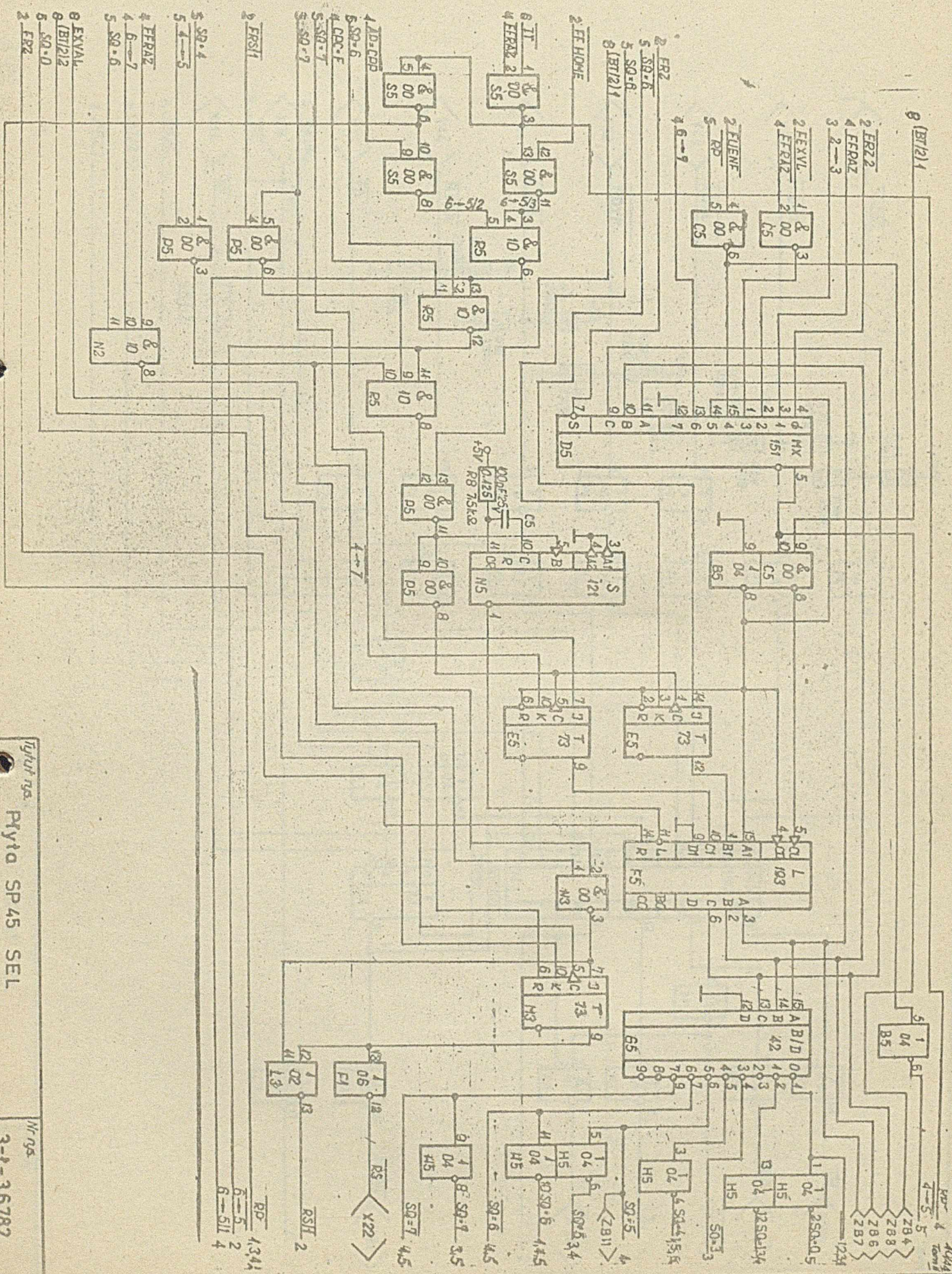

Typu rgs. Płyta SP45 SEL
schemat ideowy-ark. 5/9
Mr rgs. 3-L-36782

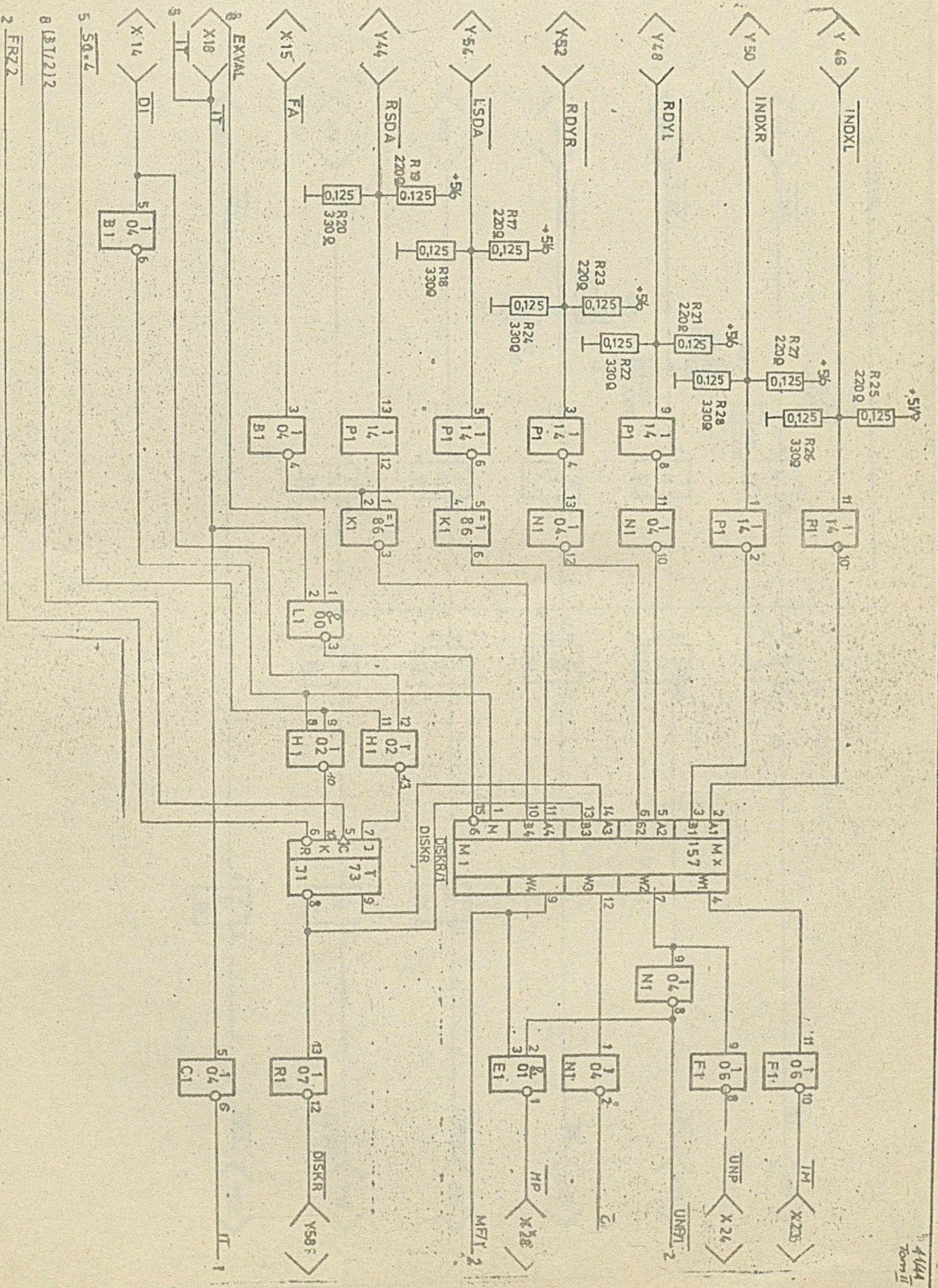

149

149

Typul rys.
Plyta SP 45 SEL
schemat ideowy-ark. 6/9

Nrys
3-2-36782

2 FEXVAL

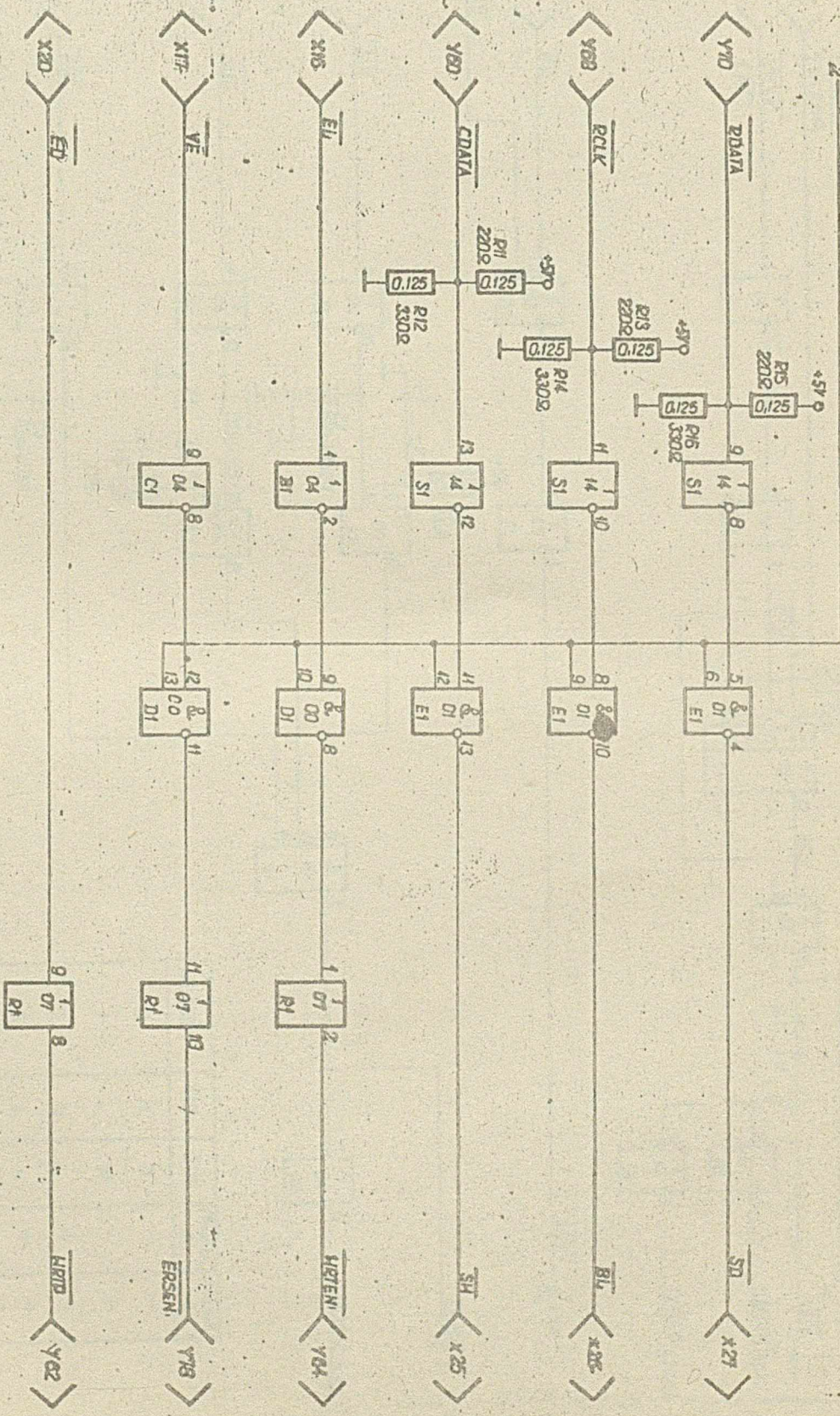

42/44
10mm II

150

150

Tytuł rys

Pyta SP 45 SEL

schemat ideowy - ark. 7/9

Nr rys

3-1-26782

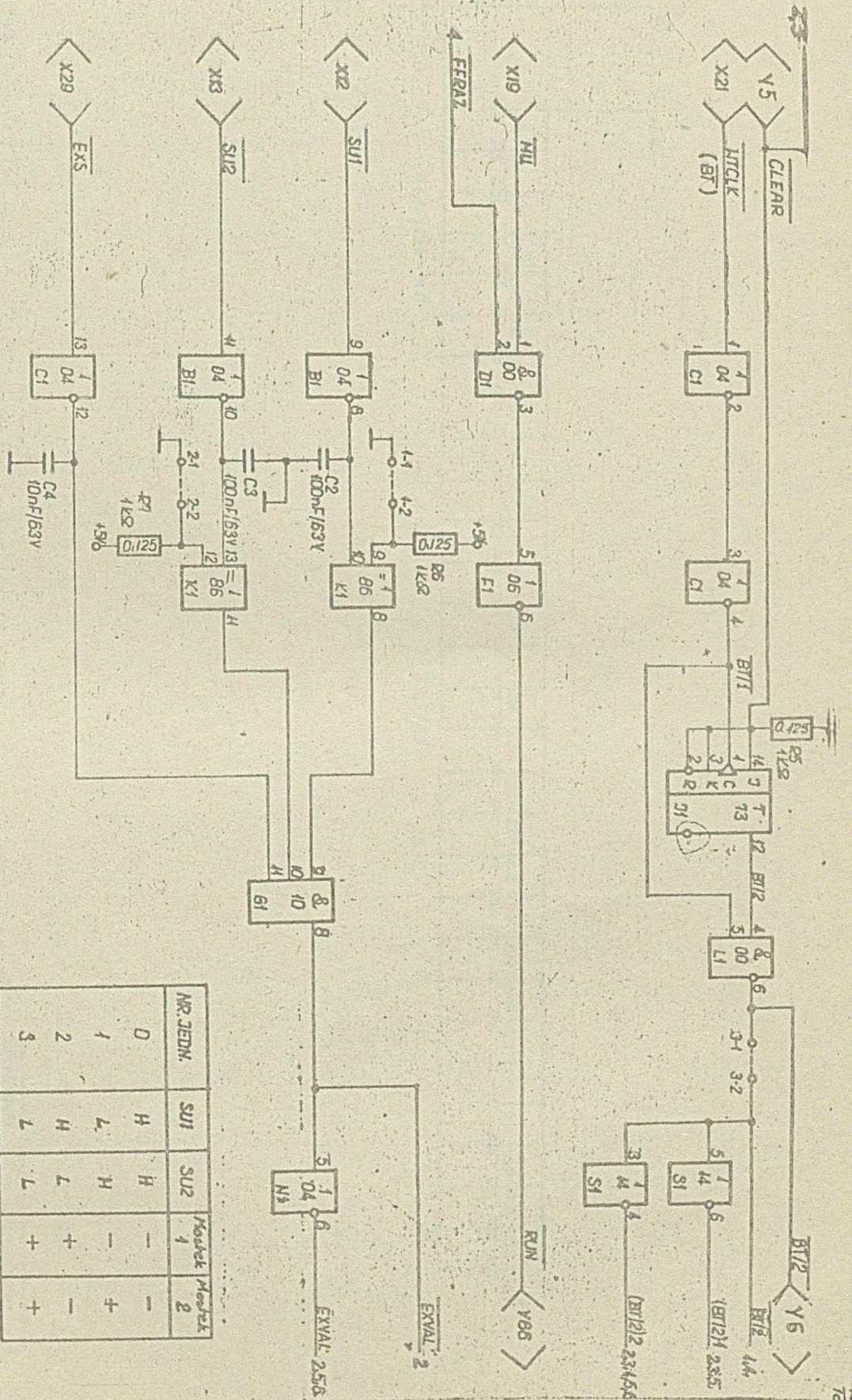

NR. JEDN.	SU1	SU2	Model 1	Model 2
0	H	H	-	-
1	L	L	+	+
2	H	L	+	-
3	L	L	+	+

151

151

Typid Ds
 Phytika SP 45 SEL
 schemat ideowy - ark 8/9

Nr Ds
 3-L-36782

13/44
 Tom II

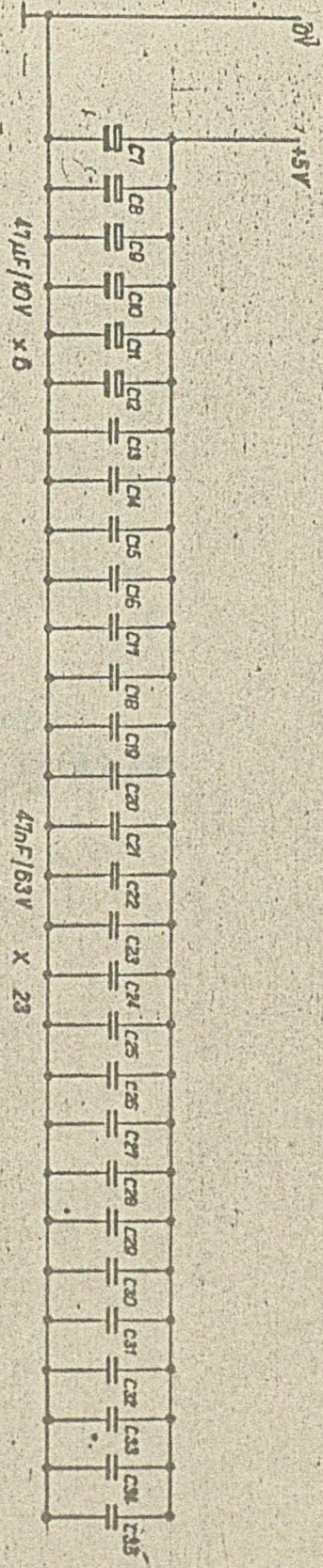

Uwaga:
 Hोंने style: Y1, Y3, Y7 + Y43.
 złączeń:

Wartość	Nr sztuk w zestawie
+5V	X1; X3; Y81; Y83;
0V	X2; X4; X22; X24; Y2; Y4; Y82; Y84;

Tytuł rys.

Płyta SP 45 SEL

Schemat ideowy - ark. 9/9

Nr rys.

3-L-36782