

## OPTIMIZATION OF COMPOSITE STRUCTURES BY THE COUPLED BOUNDARY AND FINITE ELEMENT METHOD

RADOSŁAW GÓRSKI

*Department for Strength of Materials and Computational Mechanics, Silesian University of Technology*

Abstract. The aim of the paper is to present the formulation and application of the coupled boundary and finite element method (BEM/FEM) and the evolutionary algorithm (EA) to optimization of composite structures. Plates reinforced by stiffeners, statically or dynamically loaded and analyzed by the dual reciprocity BEM and the FEM, are considered. The aim of optimization is minimization of stress concentration factor or maximization of stiffness of plates by finding an optimal length and location of stiffeners.

### 1. INTRODUCTION

Optimization is very important in practical engineering. The aim of optimization is to improve some characteristic features of structures and materials and to satisfy proper requirements. In order to increase strength, stiffness and stability, reinforced structures are used instead of non-stiffened ones. An effectiveness of reinforcement can be additionally improved in optimization process, for instance by the optimal choice of the number of stiffeners, their properties and location in a structure.

The coupling of the BEM and the FEM in elastodynamic analysis of plates stiffened by beams is presented for instance in [3]. Static analysis of plates with stress concentrators in the form of holes and cracks and reinforced by stiffeners is presented in [12] and [13]. Reinforced structures were analyzed and optimized by Górski and Fedeliński [5-10]. They were optimized by the EA using stiffness and strength criteria. The reinforcement was applied at the outer boundaries or in the interior of plates. The shape of a simply supported plate strengthened at the boundary is shown in [5]. The stiffeners position located in the interior of the above mentioned plate was searched in [8]. The shape of a homogeneous cantilever plate reinforced at the boundary and subjected to dynamic loads was optimized in [6] and [7].

In the paper, the application of the EA in conjunction with the coupled BEM/FEM in optimization of statically or dynamically loaded reinforced plates is presented. The plates are analyzed by the dual reciprocity BEM (DRBEM) [4] and the stiffeners by the FEM using beam finite elements [2]. The stiffeners are attached along the lines in the interior of the plate and during the motion they interact with the plate along the lines of attachments. The matrix equations of motion are created for the plate and the stiffeners. The transformation of the FEM nodal forces to the equivalent BEM distributed tractions is performed by using a special transformation matrix [3]. After this transformation, the finite and the boundary element equations have a similar form. The BEM and the FEM equations are coupled using compatibility of displacements and equilibrium of tractions along the attachment lines [1]. After

the boundary conditions are applied, the final set of equations is solved step-by-step giving the unknowns of the problem.

To show the application of the proposed method, numerical examples of optimization are presented. The optimal length and location of stiffeners in the plate weakened by a hole are searched in order to minimize stress concentration factors at selected points or maximize stiffness of the structure. The evolutionary optimization of this plate was presented in [9] and [10], but the stiffeners were located entirely inside a model of the plate. In the present paper, the ends of stiffeners can be located not only inside a model but also at the outer boundary of this model. The coordinates of characteristic points of stiffeners are design variables, on which the constraints are imposed. The optimization problem is solved by an evolutionary method [11]. The results of optimization are compared with the solutions obtained for the plate without reinforcement and before optimization, showing a reduction of values of objective functions.

## 2. COUPLED BOUNDARY AND FINITE ELEMENT METHOD

In the literature several methods of combining of the BEM with FEM are presented. One of these approaches, which is used in the present paper, consists in treating the finite element region as an equivalent boundary element region.

The method can be used in analysis of composite structures consisting of many domains of different homogeneous materials. Consider for instance the plate reinforced by the stiffener and subjected to dynamic load, shown in Fig.1. The structure consists of two different materials occupying regions  $\Omega^1$  and  $\Omega^2$ .

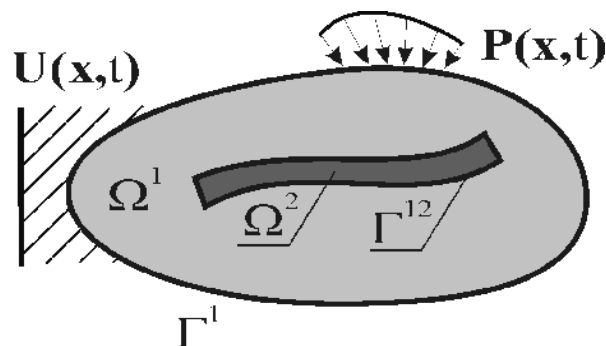

Fig.1. A plate reinforced by a stiffener

The plate ( $\Omega^1$ ) is a predominant domain modeled by the DRBEM [4] and the stiffener ( $\Omega^2$ ) is modeled by the FEM [2]. The external boundary is  $\Gamma^1$  and the attachment line (the interface connecting two materials) is  $\Gamma^{12}$ . The numerical solution is obtained after discretization of the structure. The outer boundary  $\Gamma^1$  of the plate and the attachment line  $\Gamma^{12}$  are divided into the boundary elements and the stiffener  $\Omega^2$  into the finite elements. The boundary quantities of the plate are interpolated using 3-node quadratic elements and the stiffeners are modeled by 2-node beam straight elements (3 degrees of freedom in a node). At the attachment line, each boundary element is connected with two finite elements. For the  $\Omega^1$  region, the DRBEM allows the formulation of the following system of equations of motion in a matrix form [4]:

$$[M^1 \quad M^{12}] \begin{Bmatrix} U^1 \\ U^{12} \end{Bmatrix} + [H^1 \quad H^{12}] \begin{Bmatrix} U^1 \\ U^{12} \end{Bmatrix} = [G^1 \quad G^{12}] \begin{Bmatrix} P^1 \\ B^{12} \end{Bmatrix} \quad (1)$$

and for the  $\Omega^2$  region the governing FEM equations are:

$$\mathbf{M}^{21} \ddot{\mathbf{U}}^{21} + \mathbf{K}^{21} \mathbf{U}^{21} = \mathbf{T}^{21} \mathbf{B}^{21} \quad (2)$$

where:  $\mathbf{M}$  – the mass matrices,  $\mathbf{H}$  and  $\mathbf{G}$  – the BEM coefficient matrices,  $\mathbf{K}$  – the FEM stiffness matrix,  $\mathbf{T}$  – the matrix, that expresses the relationship between the FE nodal forces and the BE tractions,  $\mathbf{U}$ ,  $\ddot{\mathbf{U}}$  are respectively displacement and acceleration vectors, and  $\mathbf{P}$ ,  $\mathbf{B}$  are vectors of tractions and body forces applied at the outer boundary  $\Gamma^1$  and the interface  $\Gamma^{12}$ , respectively. The superscripts denote the matrices which correspond to the appropriate boundaries.

The body forces are not distributed over the whole domain but they are applied along the interior line  $\Gamma^{12}$  [12]. The coefficients of the  $\mathbf{H}$ ,  $\mathbf{G}$  and  $\mathbf{M}$  BEM matrices are computed by applying of the boundary integral equations for the boundary nodes and the nodes along the attachment. If the structure is subjected to boundary conditions, the interaction forces between the plate and the stiffener act along the connection line  $\Gamma^{12}$ . These domain body forces are additional unknowns of the problem [13]. In order to couple the plate with the beam, the following displacement compatibility conditions and the traction equilibrium conditions over the interface  $\Gamma^{12}$  are used:

$$\mathbf{U}^{12} = \mathbf{U}^{21} ; \mathbf{B}^{12} = -\mathbf{B}^{21} \quad (3)$$

The above conditions used in equations (1) and (2) give the following system of matrix equations of motion for the structure in Fig.1:

$$\begin{bmatrix} \mathbf{M}^1 & \mathbf{M}^{12} \\ 0 & \mathbf{M}^{21} \end{bmatrix} \begin{Bmatrix} \ddot{\mathbf{U}}^1 \\ \ddot{\mathbf{U}}^{12} \end{Bmatrix} + \begin{bmatrix} \mathbf{H}^1 & \mathbf{H}^{12} & -\mathbf{G}^{12} \\ 0 & \mathbf{K}^{21} & \mathbf{T}^{21} \end{bmatrix} \begin{Bmatrix} \mathbf{U}^1 \\ \mathbf{U}^{12} \\ \mathbf{B}^{12} \end{Bmatrix} = \begin{bmatrix} \mathbf{G}^1 & 0 \\ 0 & \mathbf{T}^{21} \end{bmatrix} \begin{Bmatrix} \mathbf{P}^1 \\ \mathbf{P}^{12} \end{Bmatrix} \quad (4)$$

where  $\mathbf{P}^{12}$  denotes prescribed tractions at the interface. The above system of equations is modified according to the boundary conditions and solved step-by-step using the Houbolt direct integration method. The unknowns of the problem are displacements and tractions for all the boundary and the domain nodes in each time step (including non-coupled degrees of freedom, i.e. rotations of nodes for beam). The method can be used for the static analysis by assuming that the accelerations of all nodes are equal to zero.

### 3. EVOLUTIONARY ALGORITHM

The evolutionary algorithm used in the paper is a modified simple genetic algorithm which uses modified genetic operators and the floating point representation [11]. The computations start using the initial population of chromosomes randomly generated from the feasible solution domain. Each chromosome consists of genes (design variables) and represents exactly one potential solution. An objective function plays the role of a fitness function. The value of this function is computed for each chromosome in the population and some of them (usually the best) are selected for the next generation. In such algorithm, the genetic operators like mutations, crossovers and the selection are applied in order to modify populations. On each gene appropriate constraints are imposed. The procedure is repeated until the optimal solution

is reached. The optimal design is the best chromosome of all generations. Genes of this chromosome define geometry of an optimal structure.

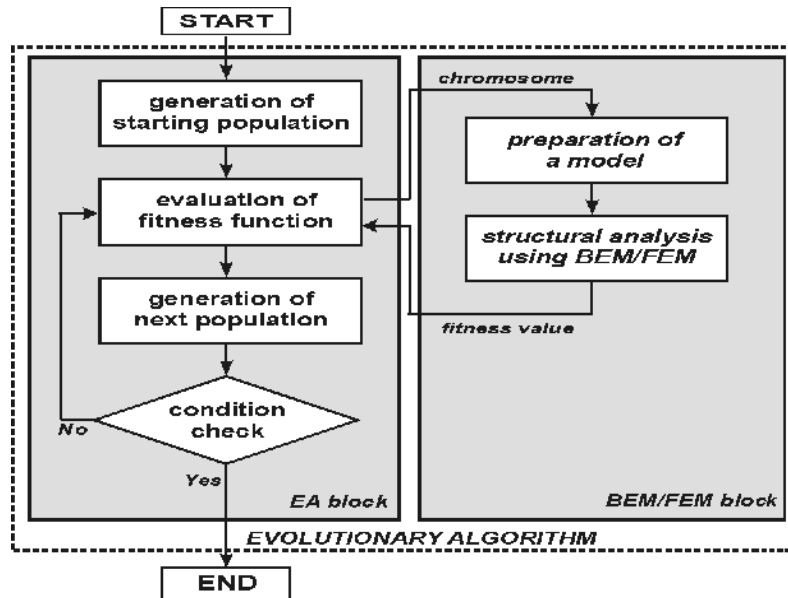

Fig.2. Evolutionary algorithm

A scheme of the evolutionary algorithm used in the paper is shown in Fig.2. To evaluate a fitness function for each chromosome, first the parameters which specify the geometry of a structure are randomly generated. Then a BEM/FEM model is prepared and the structure is analyzed. The objective function is computed using displacements, tractions and stresses obtained in the analysis.

#### 4. NUMERICAL EXAMPLE

The aim of the example is optimization of the rectangular plate [9] with a hole, reinforced by 4 beams of circular cross-section and statically or dynamically loaded as shown in Fig.3. The plate is stretched by the uniformly distributed load applied at the left and the right edge. For the dynamic case the load  $p(t)$  is defined by a Heaviside impulse. The value of the load is  $p=10 \text{ MPa}$ . The length and the height of the structure and the hole radius are respectively  $L=10 \text{ cm}$ ,  $H=5 \text{ cm}$  and  $R=1 \text{ cm}$ . The thickness of the plate is  $t=1 \text{ cm}$  and the diameter of each beam is  $d=0.3 \text{ cm}$ . The materials of the plate (p) and the beams (b) are epoxy and steel in plane stress, respectively. The materials are homogeneous, isotropic and linear elastic. The values of mechanical properties are as follows: modulus of elasticity  $E_p=4.5 \text{ GPa}$  and  $E_b=210 \text{ GPa}$ , Poisson's ratio  $\nu_p=0.37$  and  $\nu_b=0.3$ , density  $\rho_p=1160 \text{ kg/m}^3$  and  $\rho_b=7860 \text{ kg/m}^3$ .

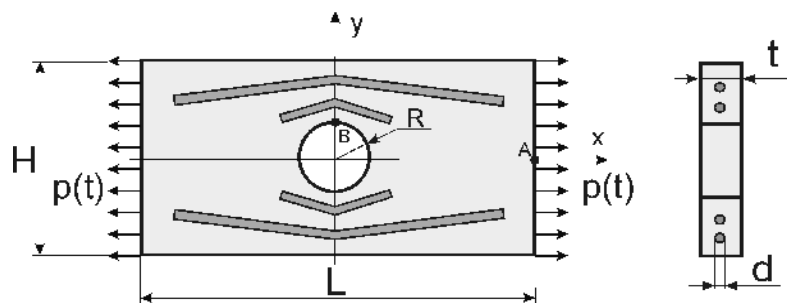

Fig.3. Reinforced plate with a hole

The aim of optimization is to find the location of the reinforcement (the beams) at the interior of the plate. The following objective functions  $J$  for statics and dynamics are used:

- minimization of the stress concentration factor  $K$  at the point B (see Fig.3)

$$J = K = \frac{S_{max}^B(t)}{S_{nom}} \quad (5)$$

- minimization of the average horizontal displacement along the loaded edge in the analyzed time (maximization of stiffness)

$$J = \frac{1}{N} \sum_{n=1}^N \frac{1}{M} \sum_{m=1}^M u_x^{nm} \quad (6)$$

where  $S_{max}^B(t)$  is a static or maximal dynamic normal stress at the point B,  $S_{nom}$  is a nominal static stress at the weakened cross-section, defined as a ratio of the applied load to the area of this cross-section,  $u_x^{nm}$  is a horizontal displacement at a node  $m$  at the loaded edge and at the time step  $n$ ,  $M$  is a number of all nodes at the loaded edge,  $N$  is a number of time steps and  $t$  is a time.

It is assumed that during optimization the reinforcement is symmetrical with respect to two symmetry axes thus only the quarter of the structure (the upper right part) with two beams and the appropriate boundary conditions at the symmetry axes is modeled.

The objective functions given by (5) and (6) are minimized with respect to design variables  $(X_i, Y_i, i=1,2)$ , defining the coordinates of the end of the  $i$ -th beam (see Fig.4). The coordinates of the beginning of 2 beams at the symmetry line are fixed: the  $x$  coordinates are equal to 0 cm and the  $y$  coordinates are equal to 1.5 cm and 2 cm for the beam near the hole and the outer boundary, respectively. The number of design variables is 4 on which the constraints are imposed. The ends of the beams can move inside the area of the dashed-line pentagon shown in Fig.4. The connection or intersection of beams is not admissible and the distance between two ends of the beams and the boundary can not be lower than 0.5 cm.

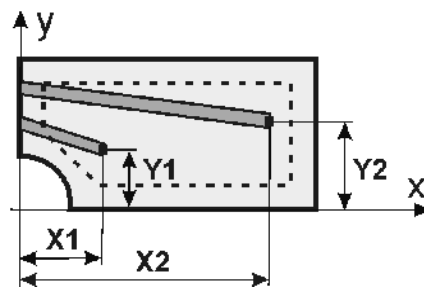

Fig.4. Design variables and constraints

The total number of boundary and finite elements in the BEM/FEM analysis is 92 and 64, respectively (each beam is discretized into 32 finite elements). The time of analysis is 300 ms and the time step  $Dt=3$  ms. The number of chromosomes in the population is 10 and the number of generations of the EA is 200.

The values of the objective functions  $J$  for the optimal designs and the plate before optimization, called the reference plate (design variables for this plate are given in Table 1 and Table 2), are compared with the values for the plate without reinforcement.

#### 4.1. Minimization of the stress concentration factor $K$ at the point B

The results of optimization obtained by the evolutionary algorithm for the static and dynamic problem are presented. The criterion of optimization is minimization of the stress concentration factor  $K$  given by (5). The values of design variables for the optimal solutions, the values of the stress concentration factors ( $SCF$ ) and their reduction  $R=(K_o-K)/K_o \cdot 100\%$  (where:  $K_o$  is the  $SCF$  for the plate without stiffeners and  $K$  is the  $SCF$  for the reference or the optimal plate), are presented in Table 1.

It can be observed that the reduction  $R$  for the reference plate and the optimal designs is significant in comparison with the plate without reinforcement. The values of the  $SCF$  are similar for the reference and the optimal plates, as for the static as for the dynamic load. It is due to similar location and the length of the reinforcement in the interior of the plate. The optimal structures for statics and dynamics are shown in Fig.5a and Fig.5b. For the optimal designs the beams are parallel to the direction of the applied load.

Table 1. Values of design variables,  $SCF$  and  $R$

Plate	Statics						Dynamics					
	Design variables [cm]				$SCF$	$R$ [%]	Design variables [cm]				$SCF$	$R$ [%]
	X1	X2	Y1	Y2			X1	X2	Y1	Y2		
Non-stiffened	-				2.23	-	-				5.16	-
Reference	4.5	4.5	1.5	2.0	0.59	73.5	4.5	4.5	1.5	2.0	1.27	75.4
Optimal	2.81	4.5	1.5	2.0	0.57	74.4	1.65	4.28	1.5	2.0	1.20	76.7

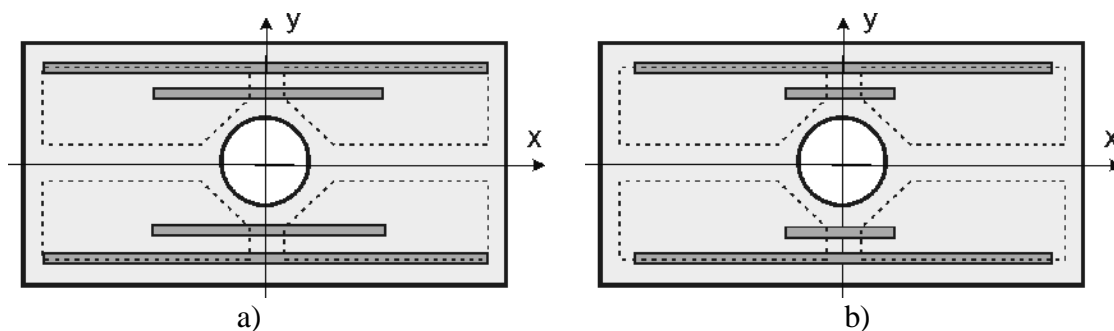

Fig.5. Optimal structures: a) statics, b) dynamics

#### 4.2. Minimization of the average horizontal displacement along the loaded edge

The results of optimization obtained by the EA, when the criterion of optimization is minimization of the average horizontal displacement ( $U_{aver}$ ) along the loaded edge given by (6), are presented. The values of design variables for the optimal designs, the values of  $U_{aver}$  and its reduction  $R=(J_o-J)/J_o \cdot 100\%$  (where:  $J_o$  is the  $U_{aver}$  for the plate without stiffeners and  $J$  is the  $U_{aver}$  for the reference or the optimal plate), are shown in Table 2.

As in the previous example, the reduction  $R$  for the reference plate and the optimal designs is significant in comparison with the plate without reinforcement. Due to similar location and the length of the stiffeners for the reference and the optimal plate, the values of the average displacements are similar, as for the static as for the dynamic load. The optimal structures for statics and dynamics are shown in Fig.6a and Fig.6b.

Table 2. Values of design variables,  $U_{aver}$  and  $R$ 

Plate	Statics						Dynamics					
	Design variables [cm]				$U_{aver}$ [ $10^{-4}$ cm]	$R$ [%]	Design variables [cm]				$U_{aver}$ [ $10^{-4}$ cm]	$R$ [%]
	X1	X2	Y1	Y2			X1	X2	Y1	Y2		
Non-stiffened	-				133	-	-				126	-
Reference	4.5	4.5	1.5	2.0	53	60.2	4.5	4.5	1.5	2.0	53	57.9
Optimal	4.5	4.5	0.89	2.0	50	62.4	4.5	4.28	0.92	2.0	51	59.5

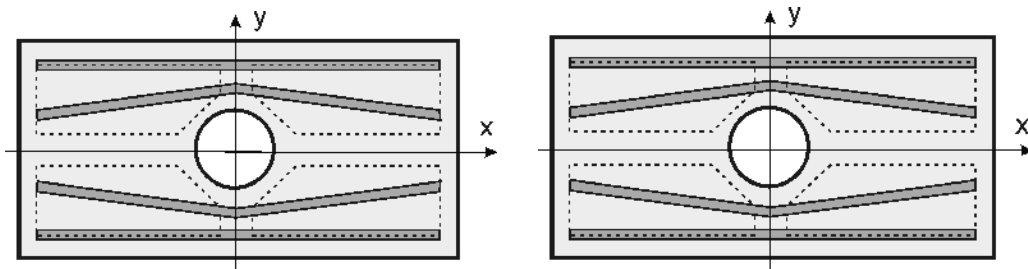

a)

b)

Fig.6. Optimal structures: a) statics, b) dynamics

## 5. CONCLUSIONS

In the paper, the coupled boundary and finite element method and the evolutionary algorithm are used in optimization of statically and dynamically loaded plate, weakened by a hole and reinforced by stiffeners. The criterion of optimization is minimization of a stress concentration factor at a selected point of the structure or maximization of its stiffness. The reinforcement has improved static and dynamic stiffness and strength. For the optimal designs an improvement of static or dynamic response is obtained in comparison with the initial solutions and with structures without reinforcements.

## REFERENCES

1. Brebbia C.A. and Dominguez J.: Boundary elements. An introductory course. 2<sup>nd</sup> ed., CMP and McGraw-Hill, Southampton and New York 1992.
2. Chandrupatla T.R. and Belegundu A.D.: Introduction to finite elements in engineering. Prentice-Hall, Inc., New Jersey 1991.
3. Coda H.B., Venturini W.S. and Aliabadi M.H.: A simple coupling of 2D BEM and FEM bar model applied to mass matrix elastodynamic analysis. Boundary Elements XIX (Marchetti M., Brebbia C.A., Aliabadi M.H. eds), CMP, Southampton, UK, Boston, USA 1997, p. 137-146.
4. Dominguez J.: Boundary elements in dynamics. CMP, Southampton 1993.
5. Górski R. and Fedeliński P.: Optimization of stiffened plates by the coupled BEM/FEM and the evolutionary algorithm. In Proceedings of the 6<sup>th</sup> World Congress on Computational Mechanics in conjunction with the 2<sup>nd</sup> Asian-Pacific Congress on Computational Mechanics, Beijing, China, Abstract, Vol. II. Tsinghua University Press,

- Springer-Verlag (Yao Z.H., Yuan M.W., Zhong W.X. eds), 2004, p. 448 (CD-ROM Proceedings - 7 pages).
6. Górski R. and Fedeliński P.: Evolutionary shape optimization of reinforced plates. Methods of Artificial Intelligence (Burczyński T., Cholewa W., Moczulski W. eds), Gliwice 2004, p. 69-70.
  7. Górski R. and Fedeliński P.: Evolutionary shape optimization of plates with reinforcements. In the Proceedings of the Third MIT Conference on Computational Fluid and Solid Mechanics, Cambridge, USA, Elsevier Ltd. UK (ed Bathe K.J.), 2005, p. 239-242.
  8. Górski R. and Fedeliński P.: Optimal reinforcement of dynamically loaded plates. 16<sup>th</sup> International Conference on Computer Methods in Mechanics CMM-2005, CD-ROM Proceedings, Częstochowa 2005, 4 pages.
  9. Górski R.: Dynamic analysis and optimization of composite materials by the boundary element method. PhD Thesis, Supervisor: Prof. P. Fedeliński, Gliwice 2005.
  10. Górski R. and Fedeliński P.: Evolutionary optimal reinforcement of a weakened plate. Methods of Artificial Intelligence (Burczyński T., Cholewa W., Moczulski W. eds), Gliwice 2005, p. 55-56 (CD-ROM Proceedings – 4 pages).
  11. Michalewicz Z.: Genetic algorithms + data structures = evolution programs. Springer-Verlag, Berlin 1996.
  12. Salgado N.K.: Boundary element method for damage tolerance design of aircraft structures. Topics in Engineering, Computational Mechanics Publications, Southampton-Boston, Vol. 33, 1998.
  13. Salgado N.K. and Aliabadi M.H.: The application of the dual boundary element method to the analysis of cracked stiffened panels. Engineering Fracture Mechanics, Vol. 54, No. 1, 1996, p. 91-105.

## **OPTIMALIZACJA UKŁADÓW KOMPOZYTOWYCH ZA POMOCĄ POŁĄCZONEJ METODY ELEMENTÓW BRZEGOWYCH I SKOŃCZONYCH**

Streszczenie. Celem pracy jest przedstawienie sformułowania i zastosowania połączonej metody elementów brzegowych i skończonych (MEB/MES) oraz algorytmu ewolucyjnego (AE) w optymalizacji układów kompozytowych. Rozpatrywane są tarcze wzmacnianie elementami usztywniającymi, obciążone zarówno statycznie, jak i dynamicznie. Celem optymalizacji jest minimalizacja współczynnika spiętrzenia naprężeń lub maksymalizacja sztywności układu, poprzez optymalny dobór długości i położenia elementów usztywniających.