



Welding of girders to insert plates of composite steel-concrete structure of tower in Kuwait

A. Klimpel ^{a,*}, A. Lisiecki ^a, J. Szlek ^b

^a Welding Department, Silesian University of Technology,
ul. Konarskiego 18a, 44-100 Gliwice, Poland

^b Castolin, ul. Robotnicza 2, 44-100 Gliwice, Poland

* Corresponding author: E-mail address: andrzej.klimpel@polsl.pl

Received 15.04.2007; published in revised form 01.07.2007

ABSTRACT

Purpose: A study of influence of preheating and MMA welding technique of tee-joints of plate girders to insert plates of a composite steel-concrete structure of the telecommunication tower, on the properties and quality of the concrete in the region of the insert plate has been carried out.

Design/methodology/approach: Studies of thermo-mechanical phenomena during manual arc welding MMA of tee-joints between plate girders and insert plates were carried out to identify possible sources of the concrete damage due to high welding temperature and stresses.

Findings: It was shown that MMA welding at vertical-up position, by a rutile coated electrode of diameter 3,2 [mm], at welding current 110-120 [A], of the butt welds of tee-joints of girders and the insert plate does not cause any harmful and damaging effect to concrete, which temperature in a region of the contact with the bottom surface of the insert plate does not exceed 240 [°C] during full cycle of welding. Tensile and compression stresses of concrete are transmitted mainly by anchoring bars, fixed in concrete and also by reinforcing fabric of concrete, and do not cause any cracks of concrete.

Research limitations/implications: To achieve more consistent results of the numerical analysis of stresses and deformation distribution in the insert plate with experimental results, it is necessary to calculate plastic deformation of materials and also take into consideration nonlinear change of yield point (plasticity) as a function of temperature.

Practical implications: The technology was applied for welding of the girders to insert plates of the telecommunication tower in Kuwait.

Originality/value: Welding procedure specification ensuring high quality of the welded joints of girders and insert plate of composite steel-concrete structure.

Keywords: Welding; MMA; insert plate; Composite reinforces concrete

MATERIALS MANUFACTURING AND PROCESSING

1. Introduction

Composite steel reinforced concrete structures are commonly used for modern buildings, especially skyscrapers, such as office buildings, telecommunication towers and drilling platform [1,2,3,11]. Due to combination of specific, beneficial properties of

concrete and steel, it is possible to produce relatively cheap composite structural materials of high compressive strength, high corrosion resistance, high thermal isolation coefficient and simultaneously high tensile strength and high plasticity. This kind of structure was used in the project of the telecommunication center tower in Kuwait by main contractor Swiss companies

Electrowatt Engineering Service Ltd, Telesuisse Consulting and Tillyard AG, Fig. 1. But it was questioned by the customer, Ministry of Public Works, Government of Kuwait.

The customer technical representatives had some doubts about MMA welding technology of tee-joints of plate girders, that is a component of a screw joint of a beam and an insert plate, Fig. 1, claiming especially the risk of damage of the concrete in the area of insert plates as a result of detrimental effect of welding heat input and welding distortions of the insert plates [4-8,9,10,12].

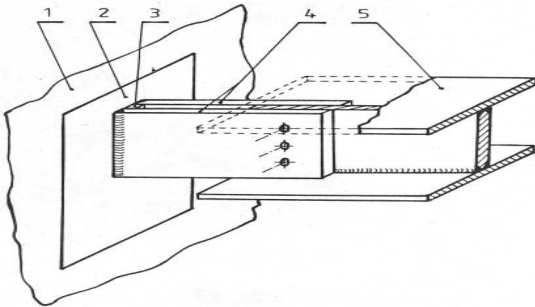

Fig. 1. A view of a joint of a steel beam and a composite reinforced concrete structure; 1 – a composite reinforced concrete core of the tower, 2 – an insert plate, 3 – backing distance of plate girders, 4 – plate girders of screw joints, 5 – a steel beam

2. Experimental

The study was ordered by the project contractor Electrowatt Engineering Service Ltd and one of subcontractors Mostostal Zabrze Poland, in order to work out the welding procedure of manual metal arc welding MMA of tee-joints of plate girders to the insert plates made of steel St37-3 (according to DIN 100/80), Table 1, Fig. 1. Welding procedure must eliminate any detrimental effect of welding on the concrete in the area of insert plate. Therefore studies of thermo-mechanical phenomena during manual arc welding MMA of tee-joints between plate girders and insert plates were carried out to identify possible sources of the concrete damage due to high welding temperature and stresses. The welding procedure specification (WPS) for welding of joints of plate girders to the insert plates was approved by Electrowatt Engineering Service Ltd. According to the worked out WPS of multi layer MMA welding at vertical-up position using rutile electrodes ER1.46 of diameter 4,0 [mm] and preheating up to 200 [°C], was applied. The temperature of preheating was set according to standard AWS D1.1 for defined shape of the joint, Fig. 1, and also for carbon coefficient (equivalent) of welded steel St37-3 (I melt $C_e=0,31$ and II melt $C_e=0,28$). Additional aim of preheating was to ensure drying of the components prior to welding in the conditions of extremely humid climate of Kuwait.

Table 1.
Chemical composition of the insert plate steel St37-3

Melt	Alloying elements content – [%]								
	C	Mn	Si	P	S	Cr	Ni	Cu	Al
I	0,15	0,72	0,29	0,013	0,019	0,11	0,15	0,10	0,03
II	0,13	0,67	0,23	0,022	0,022	0,12	0,17	0,09	0,03

Compressive strength of concrete depends on the type of concrete and it is in a range 5÷60 [MPa], however tensile strength of concrete is very low and hardly ever exceeds just 1,0 [MPa]. Compressive strength of concrete decreases significantly with increase of temperature. At temperature 200 [°C] compressive strength of concrete is 20 [%] lower and at temperature 400 [°C] it is 60 [%] lower than in ambient temperature. Very sudden decrease of tensile strength of concrete is observed at elevated temperatures and at temperature 200 [°C] tensile strength of concrete is 40 [%] lower and at temperature 400 [°C] as much as 75 [%]. Overheating of concrete above temperature 250 [°C] is considered as a case of failure. Concrete heated up to temperature 600 [°C] starts cracking itself and at temperature 900÷1000 [°C] concrete changes its color and spills during subsequent cooling down [1-3].

The initial analysis of thermo mechanical cycle of MMA welding process of tee-joints of girders and the insert plate embedded in the concrete showed that during the process of welding the bottom surface of the insert plate can be heated over the critical temperature of strength of concrete and also high compressive stresses can occur which can lead to cracking of the concrete. To select the proper technique and parameters of MMA welding of the tee-joints of girders and the insert plate, following criterions were chosen:

- temperature of the bottom surface of the insert plate, which is in direct contact with the concrete, can not exceed the critical temperature of 250 [°C],
- thermal distortions of the anchor plate can not cause any cracks of concrete.

Test concrete blocks were made of Portland cement type 350 and filler (sand and aggregate of ϕ_{max} 5 [mm]) in proportion 2 parts of cement and 3 parts of filler, the same as used in the telecommunication tower structure. The concrete blocks had following dimensions 450x350x200 [mm]. Concrete was reinforced by steel bars made of St3S steel, 12,0 [mm] in diameter.

At the first stage of the study, measurements of dislocations of the insert plate edges and temperatures of the bottom surface of the insert plate placed freely on the concrete were carried out.

A subsequent study was carried out for the insert plate embedded into concrete by four anchor bars made of St3S steel of diameter 12,0 [mm] and 50,0 [mm] in length, MMA welded to the bottom surface of the insert plate, similarly as in a case of a real insert plates of the telecommunication tower, Fig. 1. Two adjoining edges of the anchor plate were not covered by concrete, to make possible free deformation and measurements of the insert plate dislocations. As a result of applying four anchor bars, the plate was stiffened so strongly in the concrete that dislocation of its edges did not exceed 0,11 [mm] and the dislocation was in a range of elastic deformation. Temperature of the bottom surface of the insert plate in a region of middle point 0-0 was below 200 [°C]. The study showed that preheating of the insert plate prior to welding process does not cause any damages of concrete.

In the next stage of the study, measurements of dislocations and temperatures on bottom surface of the insert plate with anchor bars embedded into concrete during full welding cycle including preheating up to temperature 200 [°C] Fig. 2, were carried out. Similarly as in previous study, two adjoining edges of the insert plate were not covered by concrete. Test tee-joints of girders and insert plate embedded into concrete were welded according to WPS, at vertical down position, by cellulose electrode Castolin 6601 (E 38 0 RC 11 according to EN 499 or E 6013 according to AWS A5.1-91) of diameter 3,2 [mm], at welding current 110-120 [A]. Two thermo-elements Ni-NiCr were fixed in a middle region of the welded joint of girders and the insert plate, at point 0-0, Fig. 3. Measurements of the insert plate dislocation and temperatures of its bottom surface in a middle region were conducted after welding of every subsequent bead of the butt weld. Maximum temperature of the bottom surface of the insert plate in the middle region of joint, during full welding cycle, did not exceed 250 [°C]. No cracks of the concrete block were observed during welding.

For the next study a concrete block was reinforced by 4 ribbed bars of St3S steel 12,0 [mm] diameter welded to the insert plate fully embedded in the concrete, as in a case of a real composite structure of the telecommunication tower. The insert plate was preheated up to 200 [°C] and then both joints of girders and the insert plate were welded simultaneously at vertical-up position, according to WPS. During preheating and MMA welding process, temperature of the bottom surface of the insert plate did not exceed 240 [°C] in full thermal cycle of welding. After cooling down of the welded joint of girders and the insert plate, just narrow gaps between edges of the plate and concrete were observed. Width of the gaps did not exceed 0,02 [mm], so it is acceptable for this type of composite steel-concrete structure [1,3].

3. The numerical analysis

A numerical analysis by a finite elements method (FEM) using ANSYS software were carried out to evaluate the thermo-mechanical phenomena in welded joints of girders and the insert plate embedded in the composite steel-concrete material of the telecommunication tower structure. Because of symmetrical shape of the joint, calculations were done just for a half of the insert plate embedded rigidly in the concrete block. Nonlinear physical properties of steel and concrete depending on temperature were applied for calculations, but plastic deformations of materials were not taken into consideration. Also heat transfer to ambient as a result of convection on the top surface of the model was applied. The other surfaces of the numerical model were defined as adiabatic, because in real conditions the analyzed model is just a part of the composite steel-concrete structure. It was also assumed that, the heat during preheating by an acetylene-oxygen torch is evenly transferred through a whole surface in the preheating region of the insert plate and at the stage of welding the heat transfer take place on the contact surface of the insert plate and the girder. Results of the numerical analysis of temperature distribution during preheating of the insert plate are fully consistent with results of experimental measurements. After 35 minutes of preheating, the temperature in the whole preheated region reached not more than 200 [°C], at the same time the

temperature of the concrete being in the direct contact with the bottom surface of the insert did not exceed 180 [°C], Fig. 2. There is a high gradient of temperature in the contact area of the concrete and the insert plate during welding, but thanks to a thermal balance the temperature of concrete, temperature in this area do not exceed 240 [°C], Fig. 2.

Results of the analysis of deformations and stresses in the insert plate differ from the recorded empirically, because the plastic deformations of materials were not taken into consideration in the numerical analysis. However in a case of the real structure the plastic deformations of materials are a reason of relaxation of stresses and deformation. Results of the calculation of deformations and stresses can be a base just for a qualitative analysis, Fig. 3.

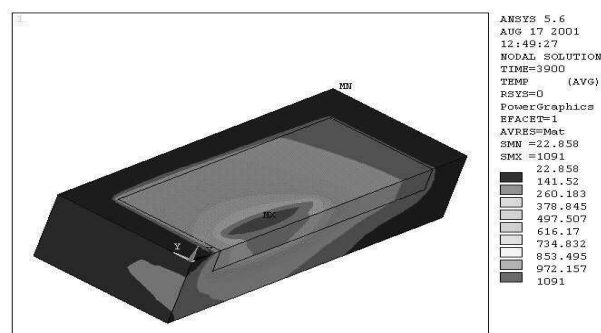

Fig. 2. 3-D temperature distribution during preheating – a) and MMA welding of the insert plate embedded in the concrete – c) d)

4. Results

Measurements of deformations and temperature distribution on the bottom surface of the insert plate which was freely placed on the concrete block, reinforced by steel bars of diameter 12 [mm], showed that preheating of the welding region of the tee-joint of girders and the insert plate up to temperature 200 [°C], Fig 1, leads to significant linear deformations up to 0,70 [mm]. So high linear deformations of freely placed of the insert plate, in case of fixing the plate, would lead to high stresses of 350-400 [MPa], significantly higher than plasticity (yield point) of St37-3 steel - 277 [MPa] and compression strength of concrete - max 60 [MPa]. Measurements of deformations of the plate fixed by anchors in the concrete block showed that anchors transmit most of thermal stresses so deformations of the insert plate embedded in concrete are limited to max. 0,11 [mm]. Temperature of the bottom surface of the insert plate does not exceed 200 [°C].

A study of manual MMA welding of joints of girders and the insert plate fixed and fully embedded in concrete, as in a case of the real structure of the telecommunication tower, Fig. 1, 2 and 3, at vertical up position by a coated electrode Castolin 6601 of diameter 3,2 [mm], at welding current 110-120 [A], showed that temperature of the bottom surface of the insert plate does not exceed 240 [°C], Fig. 2 and 3, during full thermal cycle of welding. So there is no any risk of overheating and damage of concrete during welding process. It was showed also that, thermal stresses in the insert plate do not cause any cracks of the concrete

block, just narrow gap of width below 0,02 [mm], between edges of the plate and concrete, are formed. These narrow gaps are acceptable for this type of structures [1].

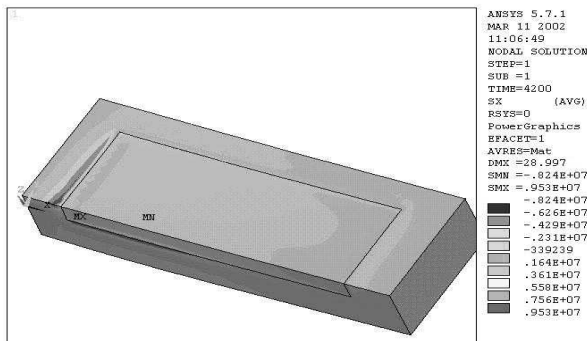

Fig. 3. A view of deformations and stresses in the concrete block and the insert plate as a result of MMA welding process

Results of the numerical analysis of temperature distribution during welding of the insert plate embedded in the concrete block are fully consistent with results of experimental measurements of temperature of the bottom surface of the insert plate and confirm that the analyzed welding procedure eliminate a risk of overheating of concrete over 250 [°C], even for a short period of time, Fig. 2 and 3.

The numerical analysis of stresses and deformations during welding of the analyzed structure showed that, similarly as the experimental study, maximum stresses concentration (and deformations) are localized in the contact area between the concrete block and the edge of the insert plate, nearest the welding region, Fig. 3.

5. Conclusions

MMA welding at vertical-up position, by a rutile coated electrode of diameter 3,2 [mm], at welding current 110-120 [A], of the butt welds of tee-joints of girders and the insert plate, Fig. 2 and 3, does not cause any harmful and damaging effect to concrete, which temperature in a region of the contact with the bottom surface of the insert plate does not exceed 240 [°C] during full cycle of welding, Fig. 2. Tensile and compression stresses of concrete are transmitted mainly by anchoring bars, fixed in concrete and also by reinforcing fabric of concrete, and do not cause any cracks of concrete.

Thermal and stress affection to concrete can be limited by applying a welding vertical down technique of MMA welding providing lower heat input, using the same rutile electrode or cellulose electrode E 42 3 C 25 according to EN 499 (E 6010 according to AWS A5.1-91) or semiautomatic arc welding by self shielding flux cored wire.

Results of the numerical analysis of temperature and stress fields distribution in the insert plate, carried out by the finite elements method and ANSYS software, showed that it is possible to identify regions where the thermal stresses and deformations reached maximum values and can lead to damages of the concrete structure, Fig. 2 and 3. These results are consistent with results recorded during preheating and welding of the insert plate

embedded in the concrete block. To achieve more consistent results of the numerical analysis of stresses and deformation distribution in the insert plate with experimental results, it is necessary to calculate plastic deformation of materials and also take into consideration nonlinear change of yield point (plasticity) as a function of temperature.

References

- [1] W. Staropolski, Calculations of concrete anchoring. Engineering and Constructions, Warsaw 1991 (in Polish).
- [2] S. Oingyu, L. Anli, Z. Haiyan, W. Aiping, Development and application of the adaptive mesh technique in the three-dimensional numerical simulation of the welding process, Journal of Materials Processing Technology 121 (2002) 167-172.
- [3] P. Maropoulos, Z. Yao, H. Bradley, K. Paramor, An integrated design and planning environment for welding: Part 1: Product modelling, Journal of Materials Processing Technology 107 (2000) 3-8.
- [4] A. Bachorski, M. Painter, A. Smailes, M. Wahab, Finite-element prediction of distortion during gas metal arc welding using the shrinkage volume approach, Journal of Materials Processing Technology 92-93 (1999) 405-409.
- [5] A. Marco, G. Trapaga, J. McKelliget, A comparison between different numerical formulations for welding arc representations, Journal of Materials Processing Technology 155-156 (2004) 1634-1640.
- [6] I. Kim, A. Basu, A mathematical model of heat transfer and fluid flow in the gas metal arc welding process, Journal of Materials Processing Technology 77 (1998) 17-24.
- [7] H. Beshr, A. Almusallam, M. Maslehuddin, Effect of coarse aggregate quality on the mechanical properties of high strength concrete, Construction and Building Materials 17 (2003) 97-103.
- [8] C. Cheng-Chih, N. Lin, Analytical model for predicting axial capacity and behavior of concrete encased steel composite stub columns, Journal of Constructional Steel Research 62 (2006) 424-433.
- [9] E. Oztekin, S. Pul, M. Husem, Determination of rectangular stress block parameters for high performance concrete, Engineering Structures 25 (2003) 371-376.
- [10] K. Lau, L. Zhou, Mechanical performance of composite-strengthened concrete structures, Composites B32 (2001) 21-31.
- [11] M. Husem, S. Gozutok, The effect of low temperature curing on the compressive strength of ordinary and high performance concrete, Construction and Building Materials 19 (2005) 49-53.
- [12] E. Karadeniz, U. Ozsarac, C. Yildiz, The effect of process parameters on penetration in gas metal arc welding processes, Materials and Design 28 (2007) 649-656.
- [13] J. Hou, W. Chung, Effect of admixtures in concrete on the corrosion resistance of steel reinforced concrete, Corrosion Science 42/9 (2000) 1489-1507.
- [14] M. Kaszynska, Early age properties of high-strength/high-performance concrete, Cement and Concrete Composites 24/2 (2002) 253-261.
- [15] T. Merikallio, R. Mannonen, V. Penttala, Drying of lightweight concrete produced from crushed expanded clay aggregates, Cement and Concrete Research 26/9 (1996) 1423-1433.