

MOSTY KRATOWE ŻELAZNE

NAPISAŁ

D^{R.} MAKSYMILIAN THULLIE,

DYPLOMOWANY INŻYNIER, PROFESOR SZKOŁY POLITECHNICZNEJ WE LWOWIE.



B. ATLAS.

=====
Cena za tekst i atlas 27⁰⁰ K.



INŻ. I. STELLA-SAWICKI

WE LWOWIE;

SKŁAD GŁÓWNY W KSIĘGARNI SEYFARThA I CZAJKOWSKIEGO.

Z I. Związkowej drukarni we Lwowie ul. Lindego 1. 4.

1905.

S. 67

S. 69

S. 70

S. 73

SPC

S. 05

SPIS TABLIC

DO MOSTÓW KRATOWYCH ŻELAZNYCH.

Tabl.	1. Most nad ul. Tolbiac w Paryżu.	Tabl.	52. Połączenie pasów z krzyżulcami.
"	2. Kształt belek głównych. Most nad koleją Batazowo-Charkowską.	"	53. " " " " "
"	3. Belki wieloboczne.	"	54. " " " " "
"	4. Kształt belek.	"	55. " " " " "
"	5. Mosty wspornikowe.	"	56. Kształt belek.
"	6. Kształt belek.	"	57. Ustrój krzyżulców.
"	7. Kształty belek.	"	58. Przeguby w belkach.
"	8. Most kolei Peruwiańskiej.	"	59. " " " "
"	" na Hudsonie 666 m rozp.	"	60. Kształt pasów.
"	" " kanale La Manche.	"	61. Krzyżulce i połączenie.
"	" " Sarinie w Fryburgu.	"	62. " " " "
"	9. Belki ciągłe.	"	63. " " " "
"	10. Kształty belek.	"	64. Most drogowy na Ohrzy w Pürsteinie.
"	11. Kształty belek.	"	65. Rozkład materyału.
"	12. Krata równoboczna.	"	66. Zakończenie kraty.
"	13. Układ kraty.	"	67. Portal nad filarem wiaduktu na Salcachu między Oberndorf i Laufen.
"	14. Kraty równoramienne.	"	68. Narożniki.
"	15. Most w Rocheckiem.	"	69. " "
"	16. Mosty włoskie.	"	70. " "
"	17. Krata równoboczna.	"	71. " "
"	18. " równoramienna.	"	72. Zakończenie belek zbieżnych.
"	19. " " "	"	73. " " " "
"	20. Krata i pasy.	"	74. Węzeł górny narożnika.
"	21. Krata.	"	75. Most kolei Arulańskiej na Innie.
"	22. Pasy.	"	76. Zakończenie belek zbieżnych.
"	23. " "	"	77. Narożniki.
"	24. " "	"	78. Zakończenie belek zbieżnych.
"	25. Belki wieloboczne.	"	79. Przekroje poprzeczne mostów.
"	26. Belki główne.	"	80. " " " "
"	27. Kształt belek głównych.	"	81. Narożniki.
"	28. Pasy.	"	82. " "
"	29. " "	"	83. Most przez Wilcze gardło na Dnieprze.
"	30. Krzyżulce.	"	84. Narożniki i progi bezpieczeństwa.
"	31. Krzyżulce ciśnione.	"	85. Pomost.
"	32. Przekroje krzyżulców i pasów.	"	86. " "
"	33. Połączenie kraty z pasem.	"	87. Połączenie podłużnie z poprzecznicami.
"	34. Pasy.	"	88. Przekrój poprzeczny mostu.
"	35. Krzyżulce.	"	89. Most w Holeszowicach.
"	36. Kształt belek głównych.	"	90. Przekroje poprzeczne.
"	37. " " " "	"	91. " " " "
"	38. Ustrój krzyżulców.	"	92. " " " "
"	39. Kształt belek.	"	93. Most drogowy na Ohrzy w Domiceulu.
"	40. Połączenie pasów.	"	94. Most na Izerze.
"	41. Ustrój pasów.	"	95. Ustrój poprzecznie.
"	42. " " " "	"	96. Utwierdzenie poprzecznic.
"	43. " " " "	"	97. Chodniki.
"	44. " " " "	"	98. " "
"	45. Połączenie mimośrodkowe.	"	99. Łożyska mostu kolei Syberyjskiej na Obie.
"	46. Blachy węzłowe.	"	100. Łożyska mostów.
"	47. Wiadukt na Wełtawie pod Czerweną.	"	101. Łożyska.
"	48. Połączenie krzyżulców.	"	102. " "
"	49. Połączenie pasów.	"	103. " "
"	50. Połączenie pasów i krzyżulców.	"	104. Przekrój poprzeczny mostu.
"	51. Połączenie pasów z krzyżulcami.	"	105. Zakończenie belek zbieżnych.



10924/2

024.3

SPIS TABLIC

DO MOSTÓW KRATOWYCH ŻELAZNYCH

ZESZYTU II.

<p>Tabl. 106. Pomost mostów kolejowych.</p> <p>" 107. Most na Dunaju pod Czarnowodą.</p> <p>" 108. Przekrój poprzeczny.</p> <p>" 109. Łożyska i przekrój poprzeczny mostu.</p> <p>" 110. Chodniki i pomost.</p> <p>" 111. Połączenie poprzeczne i belki główne.</p> <p>" 112. Łożyska kołyskowe.</p> <p>" 113. Podłużnica.</p> <p>" 114. Drogowy most kratowy na Otawie w Strakowicach.</p> <p>" 115. Przekroje poprzeczne.</p> <p>" 116. " " "</p> <p>" 117. Odstęp belek głównych.</p> <p>" 118. Połączenie łożyska z murem.</p> <p>" 119. Ubezpieczenie przeciw wykołaceniu.</p> <p>" 120. Odgraniczenie drogi od chodnika.</p> <p>" 121. Odbojnice.</p> <p>" 122. Ustrój pomostu mostów drogowych.</p> <p>" 123. Połączenie podłużnic z poprzecznkami.</p> <p>" 124. " " " "</p> <p>" 125. Odgraniczenie drogi i chodnika.</p> <p>" 126. Most na Woldze pod Twerem.</p> <p>" 127. " na Saarze pod Saarbrücken.</p> <p>" 128. Odgraniczenie drogi od chodnika.</p> <p>" 129. Tężniki.</p> <p>" 130. " "</p> <p>" 131. Przekrój poprzeczny mostu.</p> <p>" 132. Tężniki i łożyska.</p> <p>" 133. Łożyska.</p> <p>" 134. " "</p> <p>" 135. Poprzecznice.</p> <p>" 136. Podłużnice.</p> <p>" 137. Łożyska.</p> <p>" 138. " "</p> <p>" 139. Tężniki i łożyska.</p> <p>" 140. Most drogowy na Wecharze pod Mannheim.</p> <p>" 141. Latarnie.</p> <p>" 142. Tężniki.</p> <p>" 143. Połączenie tężników.</p> <p>" 144. Most na Saarze pod Brugg.</p> <p>" 145. Połączenie i skrzyżowanie tężników.</p> <p>" 146. Tężniki; ruchome połączenie podłużnicy.</p> <p>" 147. Łożyska i przekroje poprzeczne mostu.</p> <p>" 148. Poprzecznice.</p>	<p>Tabl. 149. Utwierdzenie poprzecznic.</p> <p>" 150. " " "</p> <p>" 151. Poprzecznice.</p> <p>" 152. Utwierdzenie poprzecznic.</p> <p>" 153. Łożyska.</p> <p>" 154. " wałkowe.</p> <p>" 155. " "</p> <p>" 156. " "</p> <p>" 157. Dokładka mostowa.</p> <p>" 158. Tężniki poziome.</p> <p>" 159. Łożyska wałkowe.</p> <p>" 160. " "</p> <p>" 161. " "</p> <p>" 162. " "</p> <p>" 163. Most na rzece Matt koło Braunau nad Innem.</p> <p>" 164. Łożyska.</p> <p>" 165. " "</p> <p>" 166. Poprzecznice.</p> <p>" 167. Łożyska.</p> <p>" 168. " "</p> <p>" 169. " i tężniki poprzeczne.</p> <p>" 170. Przegub mostu nad dworcem w Dreźnie.</p> <p>" 171. Tężniki.</p> <p>" 172. Przegub przy miejskim moście na Woldze w Nowogrodzie.</p> <p>" 173. Łożyska.</p> <p>" 174. Przeguby.</p> <p>" 175. Łożyska.</p> <p>" 176. " "</p> <p>" 177. Tężniki.</p> <p>" 178. " "</p> <p>" 179. " "</p> <p>" 180. " "</p> <p>" 181. " "</p> <p>" 182. " "</p> <p>" 183. " "</p> <p>" 184. " "</p> <p>" 185. } Zakotwienie mostu jarowego na Wełtawie</p> <p>" 186. } w Mirzonowicach.</p> <p>" 187. Dokładki mostowe.</p> <p>" 188. Mosty w spadzie.</p> <p>" 189. " " "</p> <p>" 190. Most Treskow w Oberschöneweide obok Berlina.</p> <p>" 191. Tężniki.</p>
--	--



Widok.

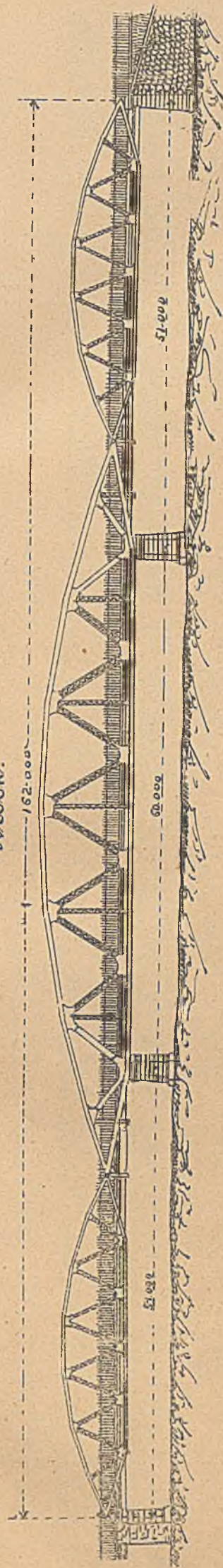

Rys. 2. Lozysko ruchome belki środkowej

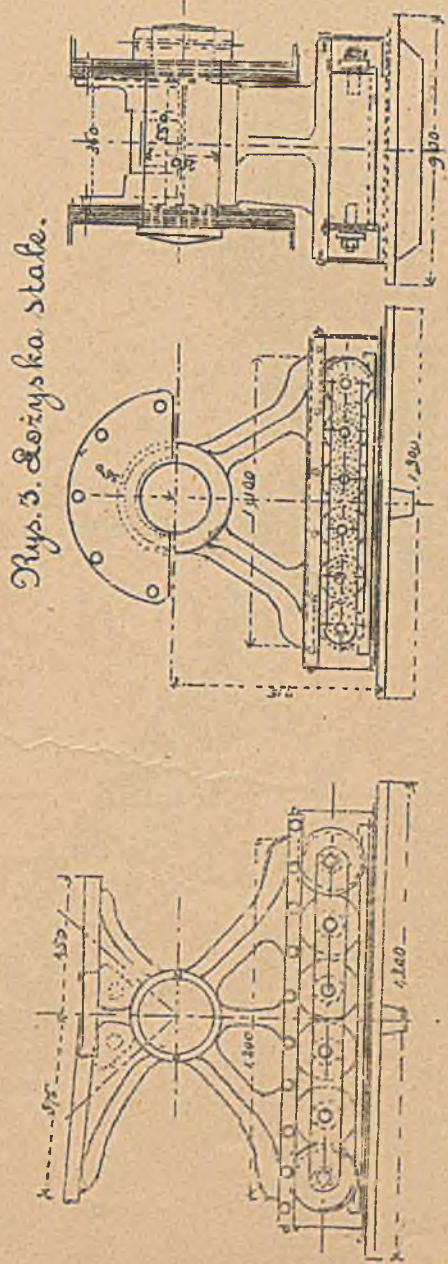

Rys. 4. Szeregół przegubu.

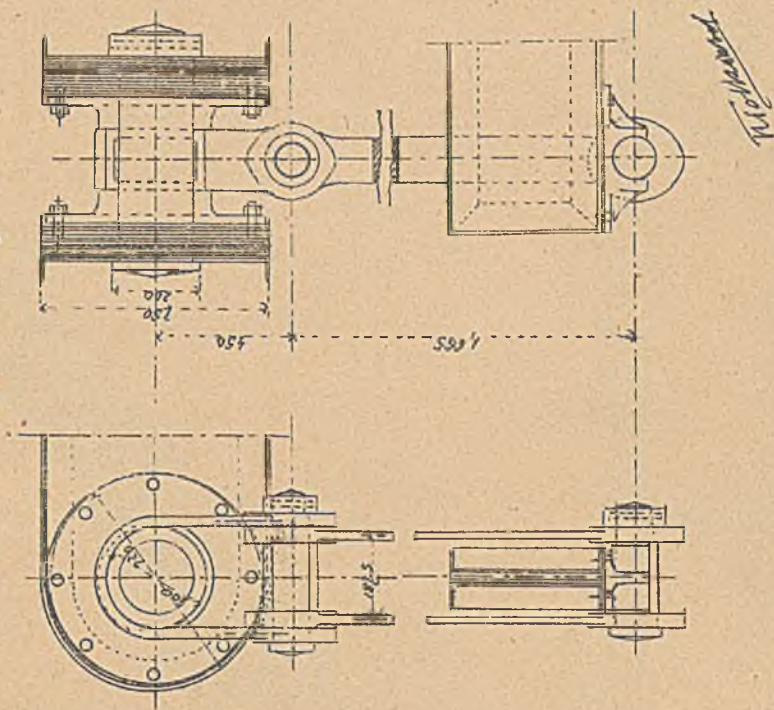

Rys. 5. Siatytwierdzenie ruchome poprzecznic.



Rys. 1. Most przejazdowy nad koleją Bafaszewo-Charłkowska.

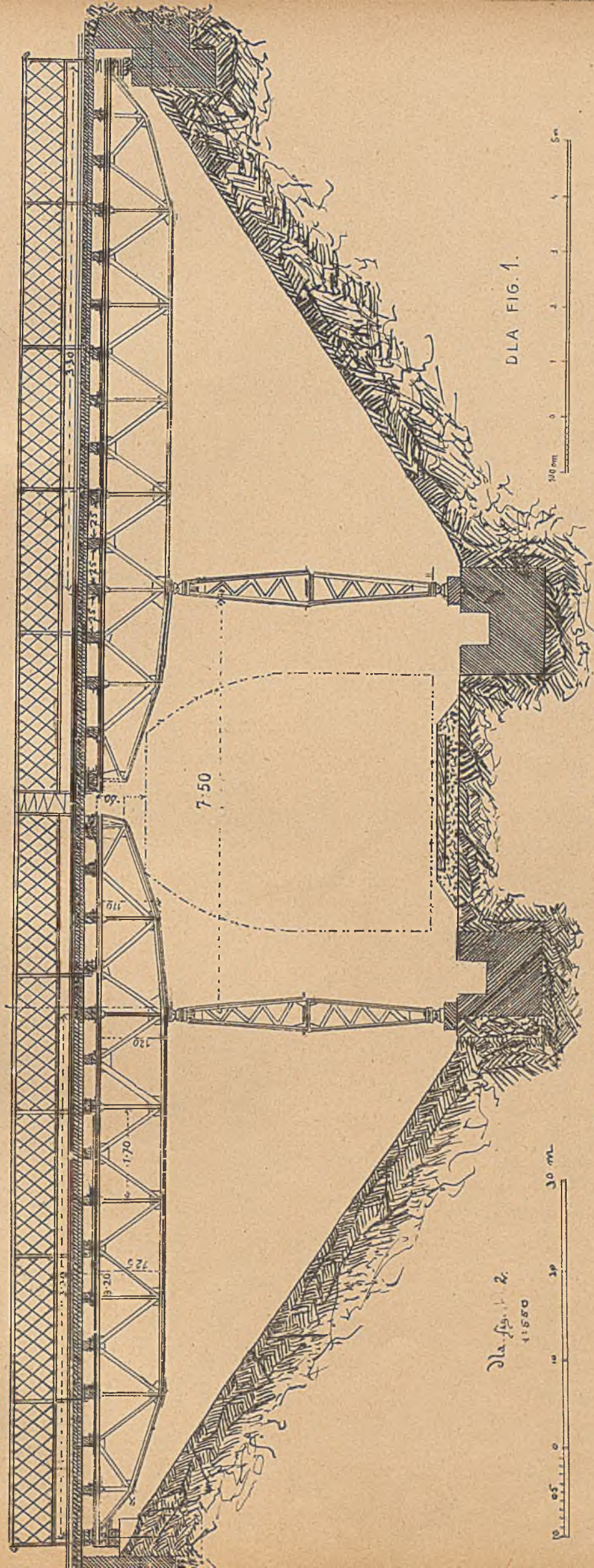

Rys. 2. Most nad Lezą pod Conz (Kolej Morska).

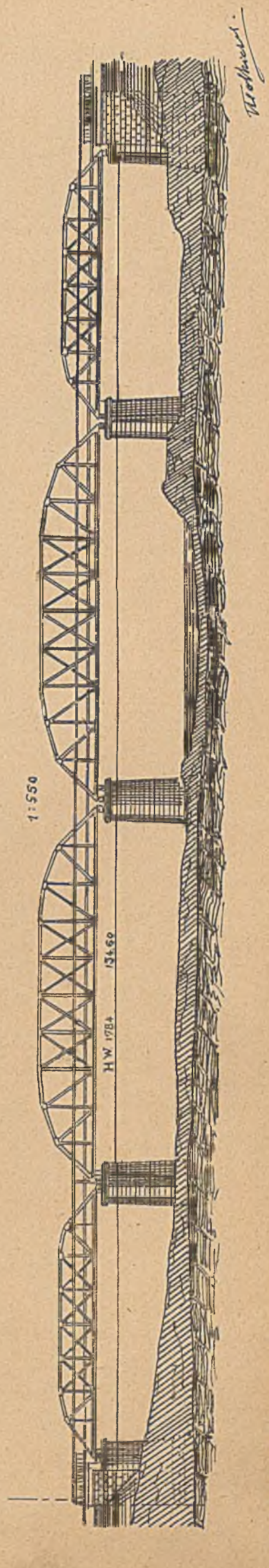

Belki wieloboczne

Rys. 1. Most kolejowy nad Dunajem w Stambach

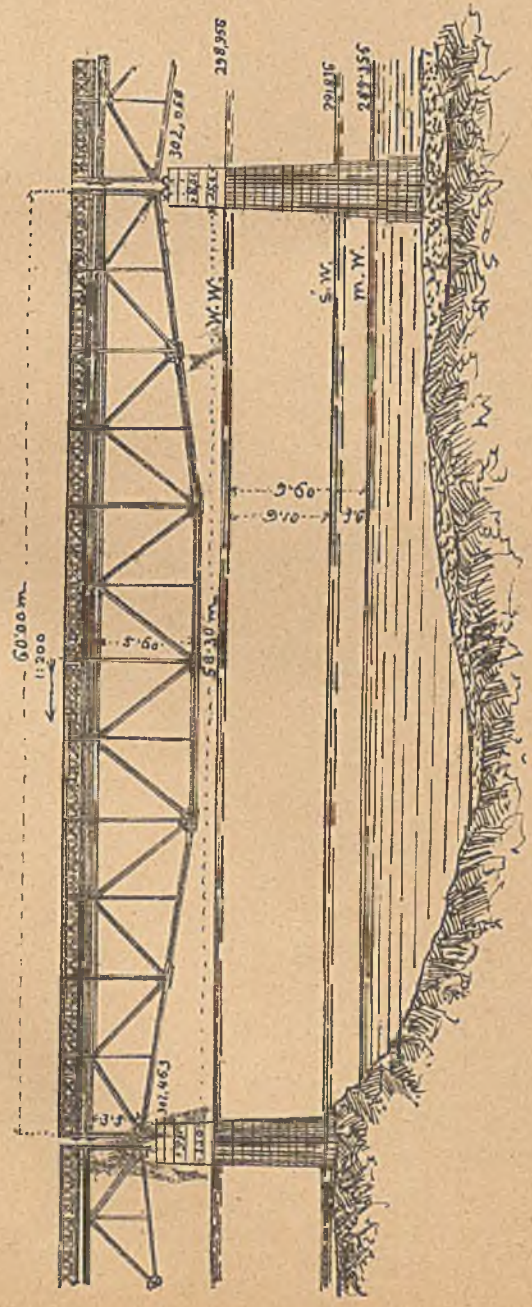

1:500

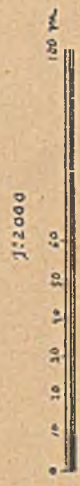

Rys. 5. Most kolei transandepskiej Buenos-Ayres-Valparaiso.

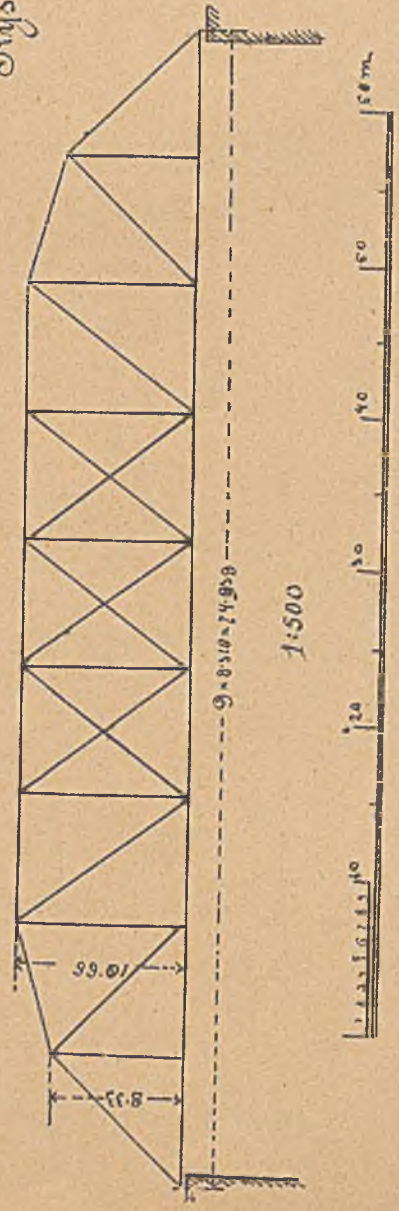

1:500

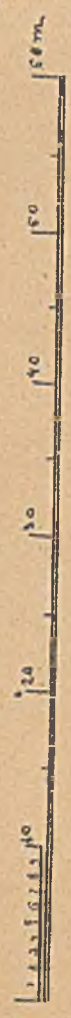

Rys. 2. Most Zofii nad kanałem w Wiedniu.

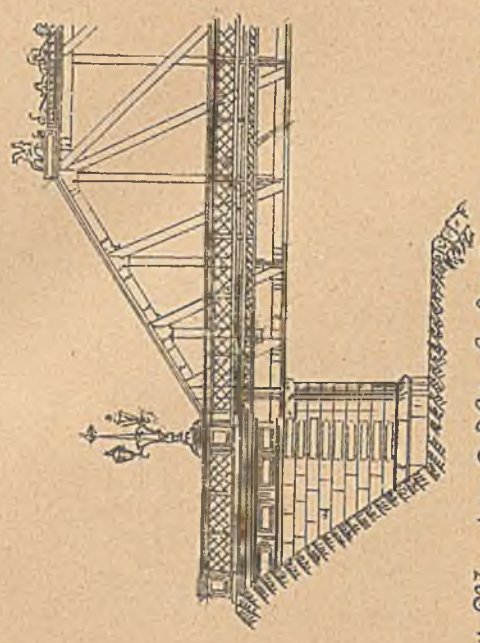

Rys. 4. Most nad Obis kolei Cincinnati-Covington

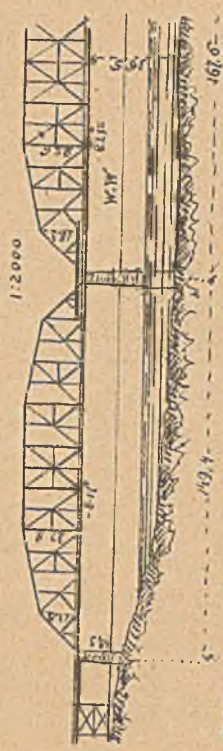

1:2000

Rys. 6. Most nad Dunajem między Stein i Montorn.

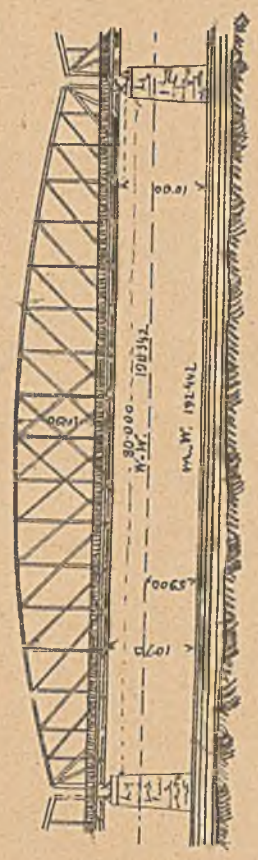

1:200

Wiedeń

Rys. 1a. Belki ciągłe Gebera.

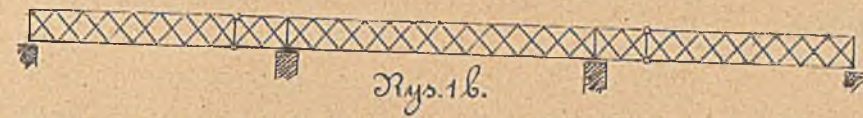

Rys. 1b.

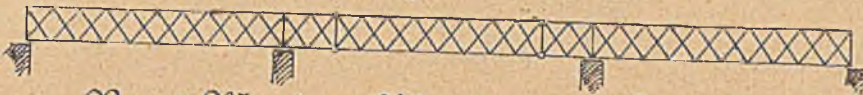

Rys. 2. Most na Mbenie w Hassfurcie.

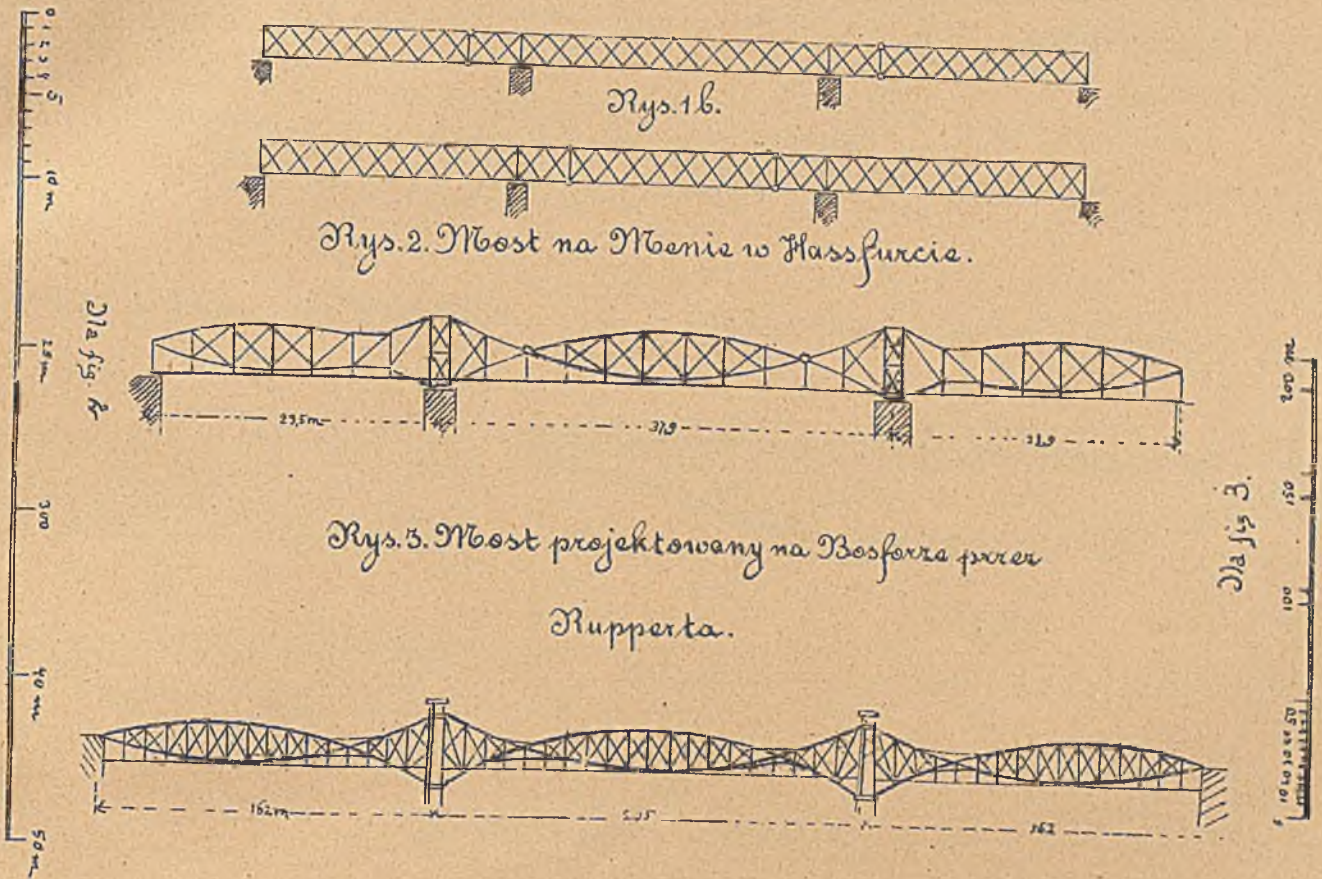

Rys. 3. Most projektowany na Bosforze przez Rupperta.

Rys. 4. Nowy most na Renie w Normacji.

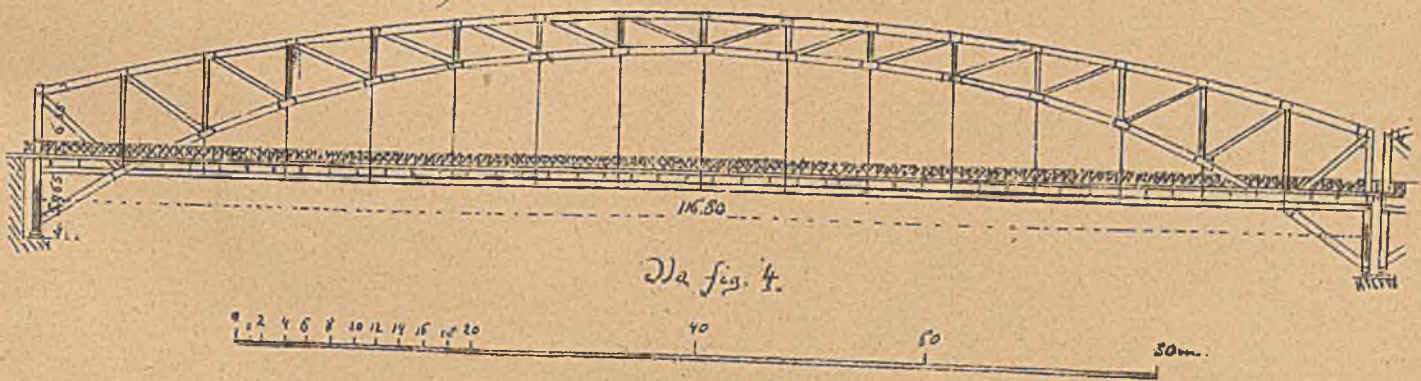

Rys. 5. Most jubileuszowy w Hoogbly w Indjach wschodnich.

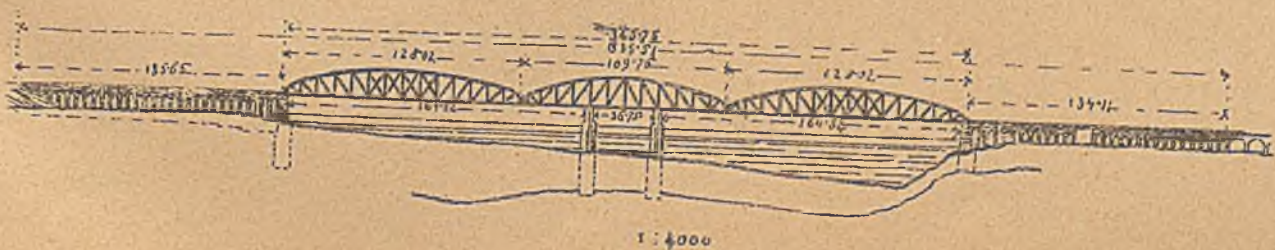

Mosty wspornikowe.

Rys. 1. Most na rzecze Sgo Jana w Ameryce północnej.

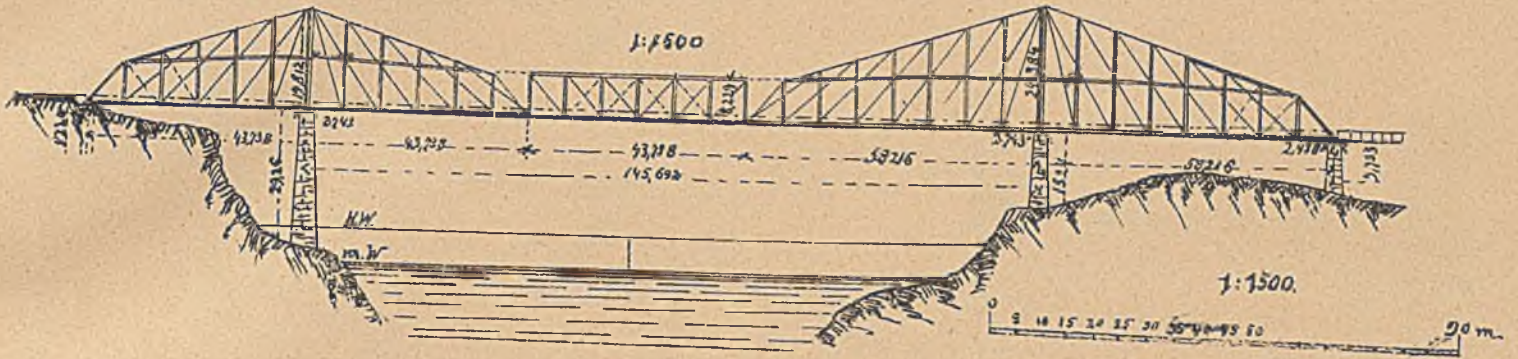

Rys. 2. Most nad rzeką Kanawha kolei Okio.

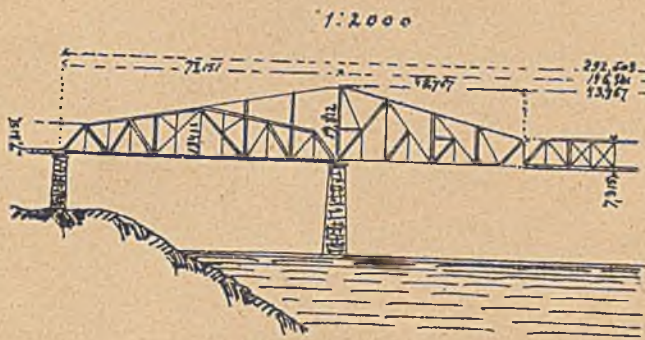

Rys. 3. Most drogowy w Albany Nowym Jorku.

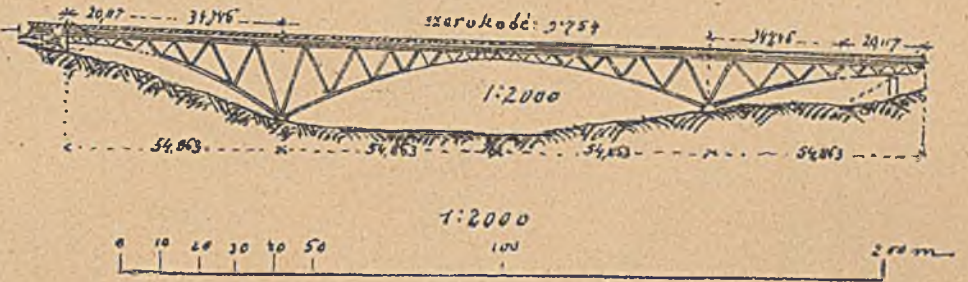

Rys. 4. Most w Louisville.

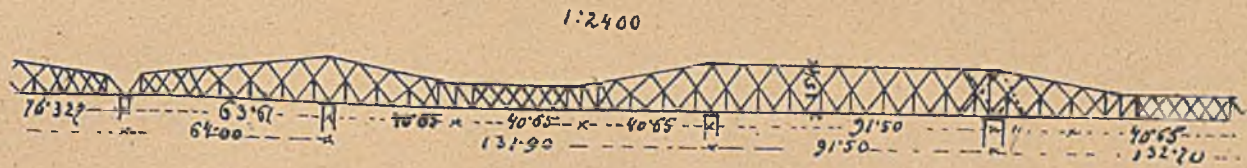

Rys. 4. Most na Niagarze.

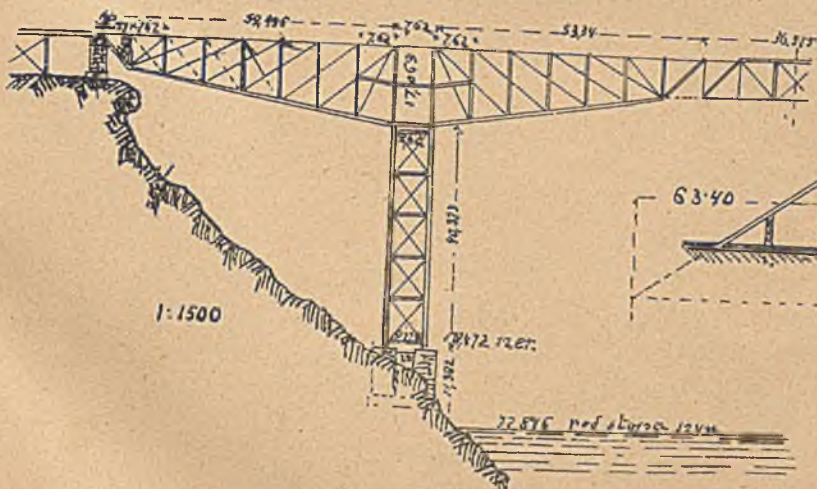

Rys. 5. Most w Sukkurze na Indusie.

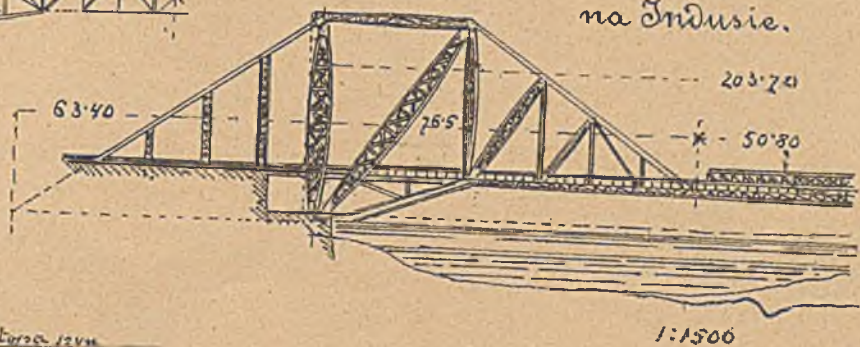

Wotho

Kształt belek.

Rys. 1. Most na Ciężym Dmajcu w Nowym Targu

kelei Chaboioka - Zakopane.

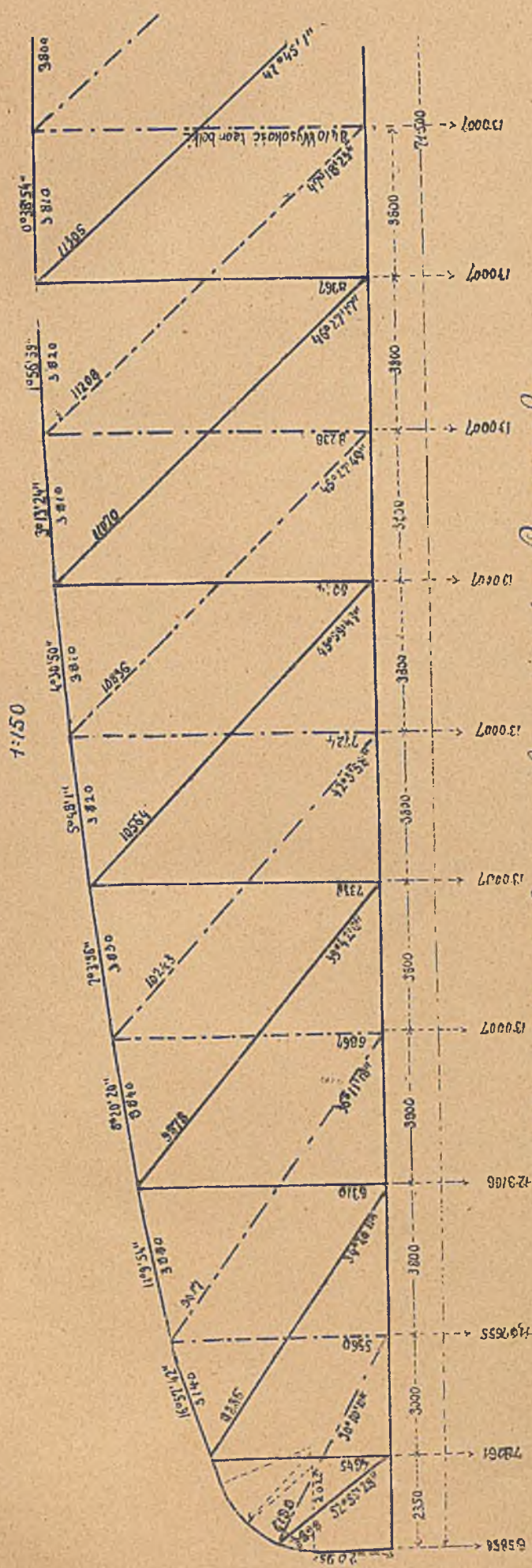

Rys. 2. Most dla pieszych na stacji w Strzaworsku.

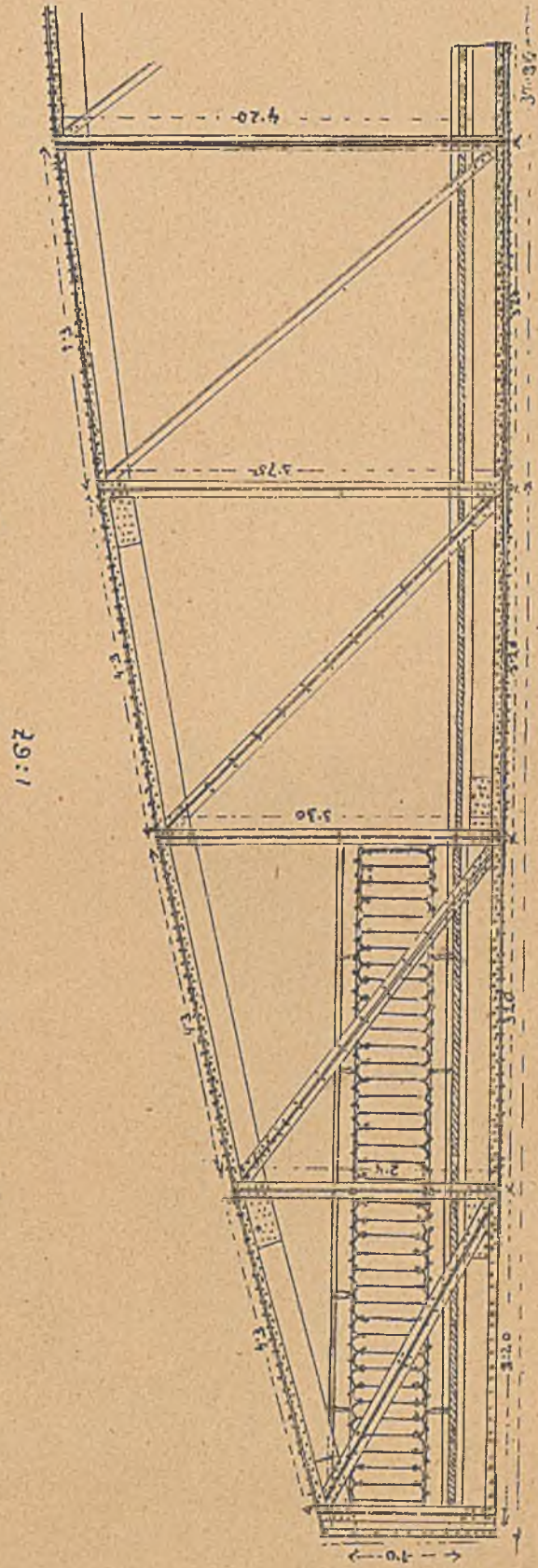

Rys. 1. Most na rzece Fortb.

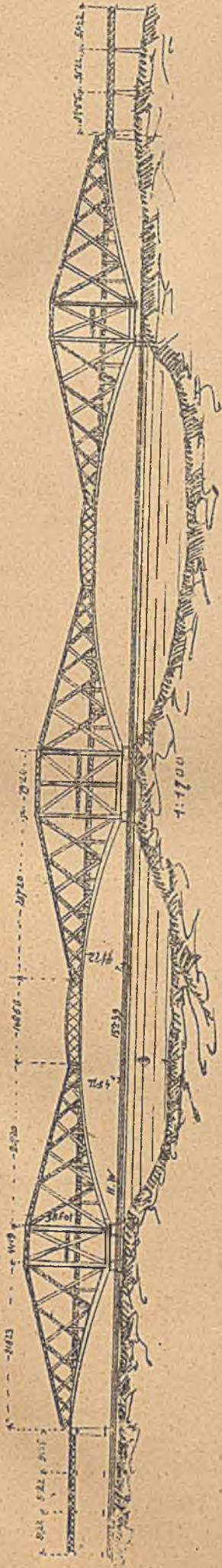

Rys. 2. Most na rzecce Św. Wawrzynca 124.25 m. rozpiętości.

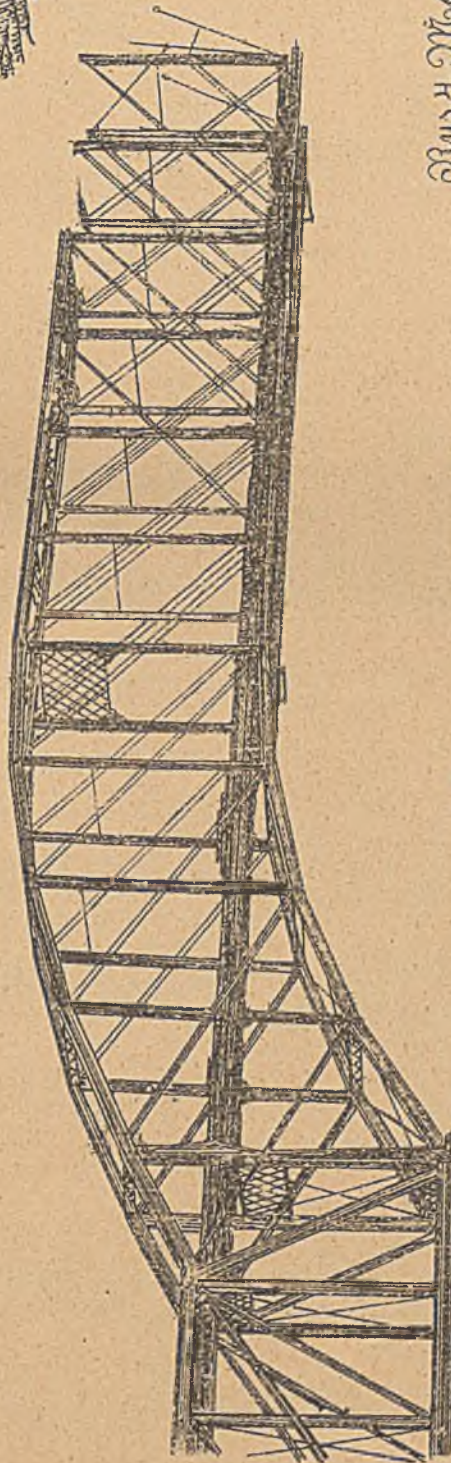

Rys. 3. Most na rzece Viar w Francyi.



Rys. 4. Most na Dunaju w Granie.

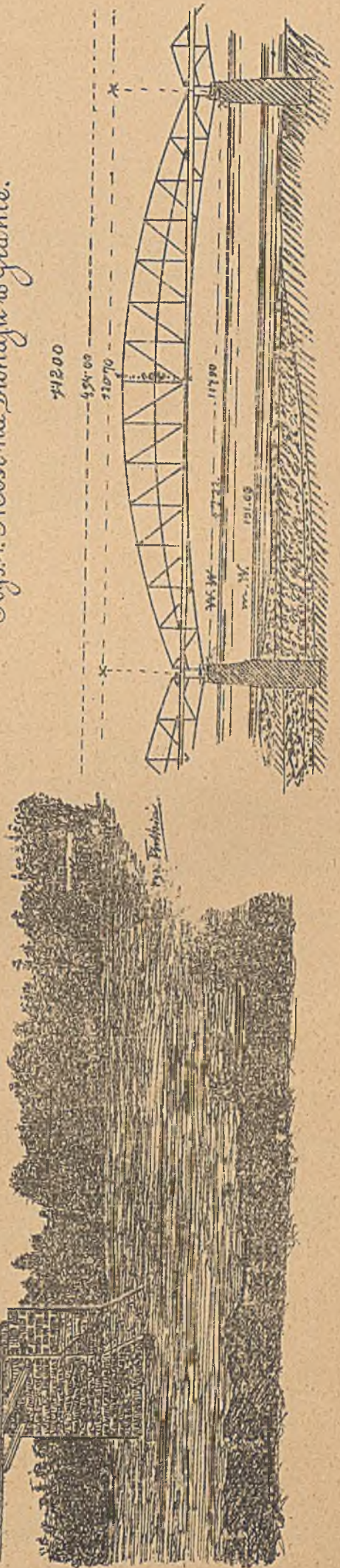

Rys. 1. Nowy most na rzece Verrugas kolei północno Peruwianiskiej.

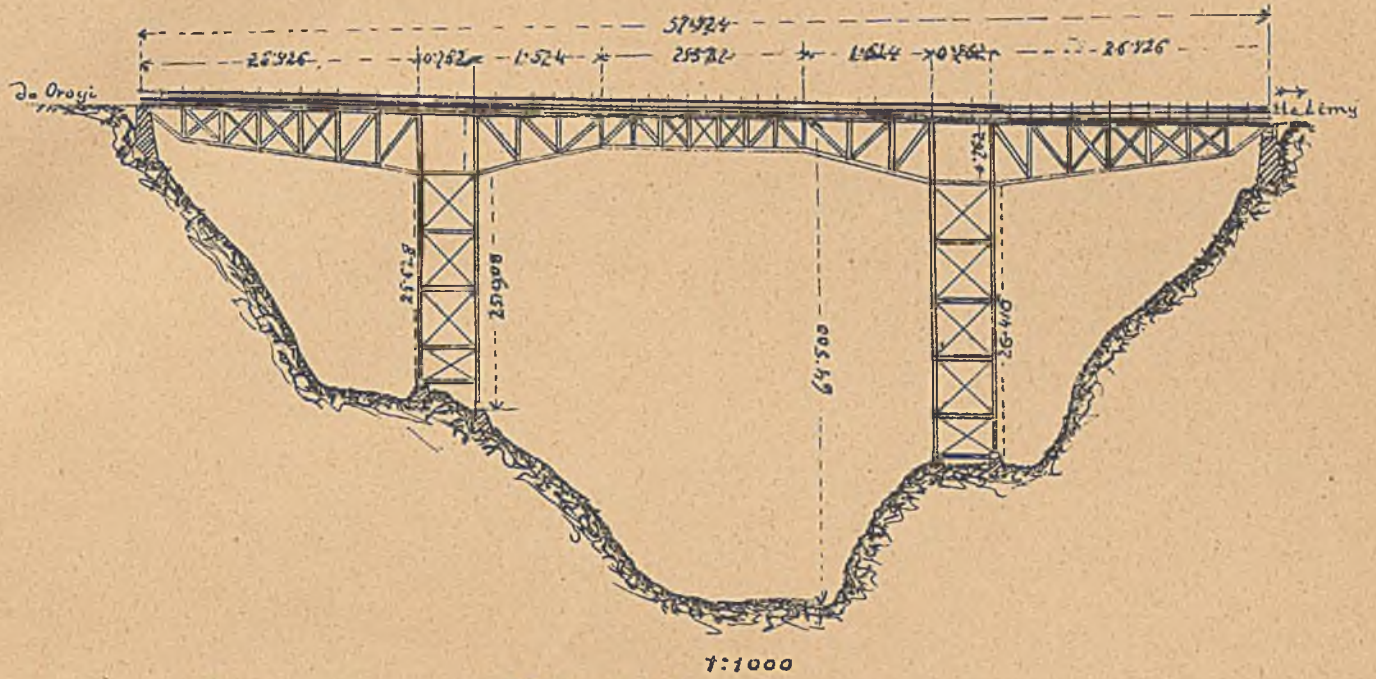

Rys. 2. Most na Hudsonie 666 m. rozpiętości.



Rys. 3. Most projektowany na kanale La Manche.



Rys. 4. Most na Sarinie w Fryburgu.

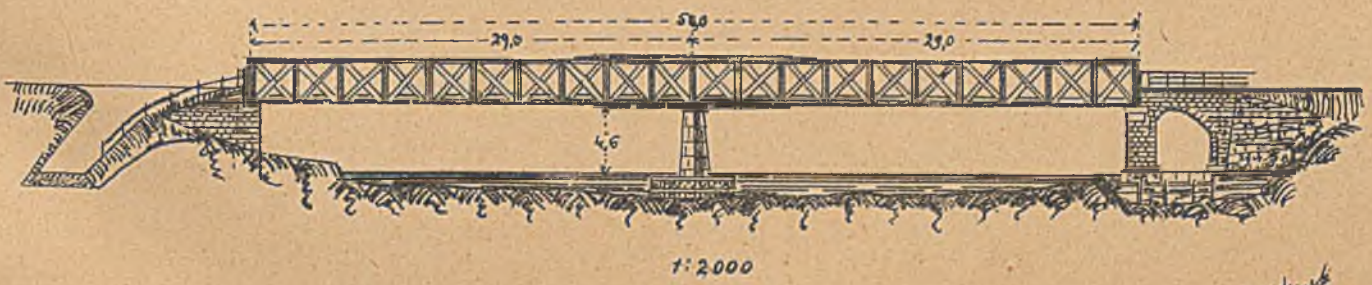

Handwritten signature or mark.

Belki ciagle.

Rys. 1. Most Troickiego w Petersburgu.

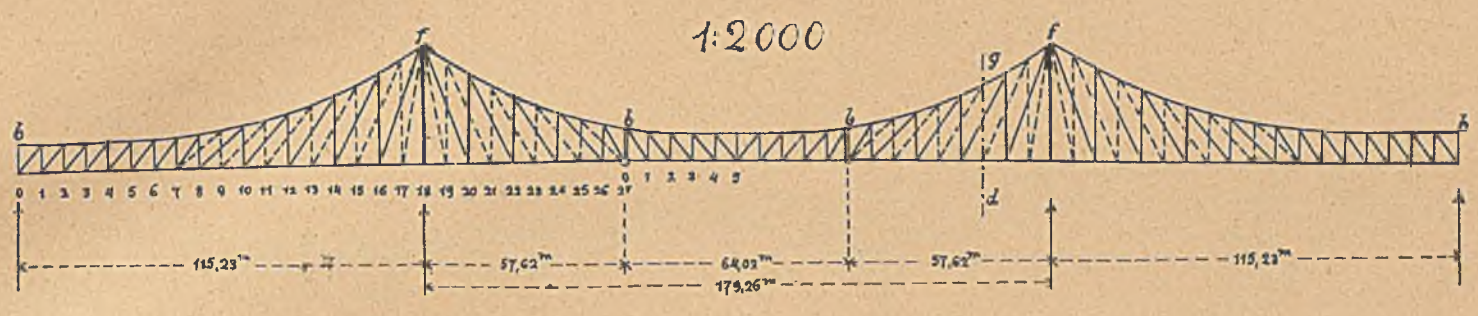

Rys. 2. Most na Colorado w Red-Rock.

1:5 mm. = 1 m.

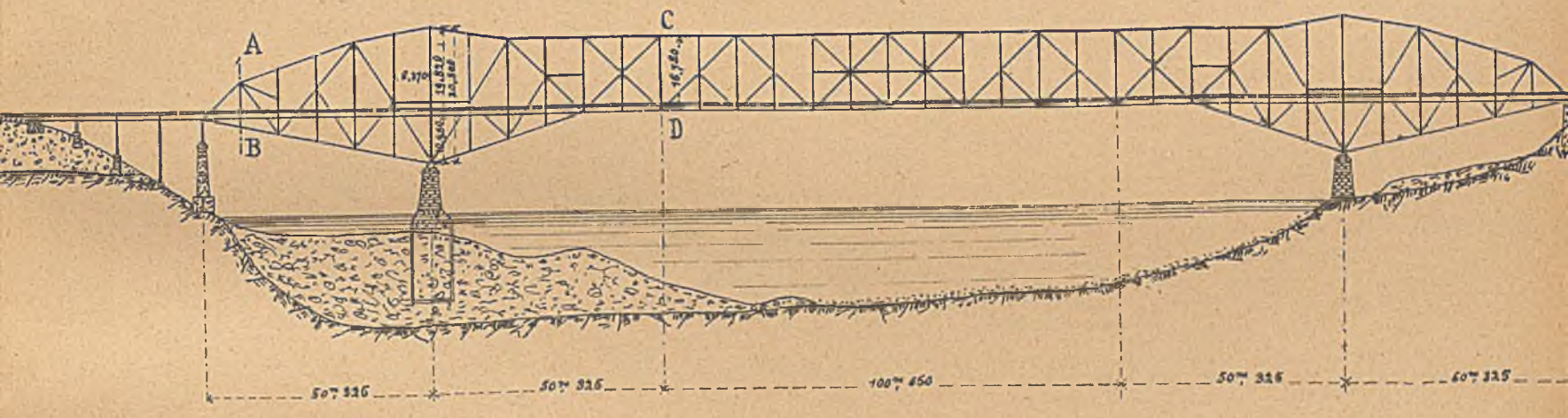

Rys. 3. Kładka w Bry-sur-Marne.

Belka ciagle.

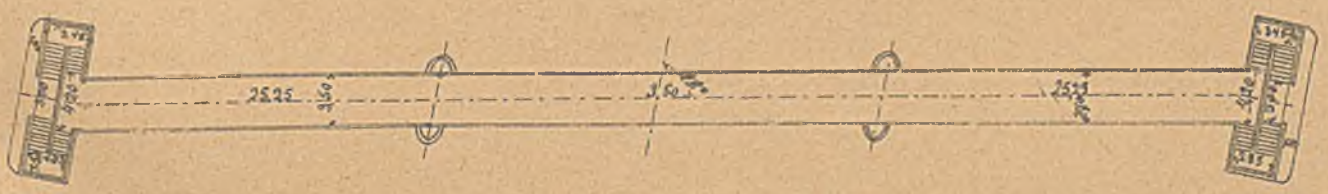
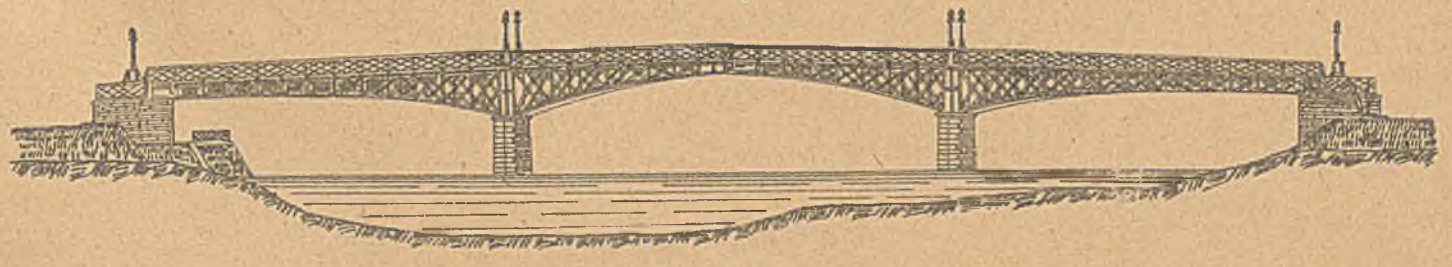

1:500

Rys. J. J. J.

Kształty belek.

Rys. 1. Most na potoku Findeln kolei żelaznej.

1 m. = 1.5 mm.

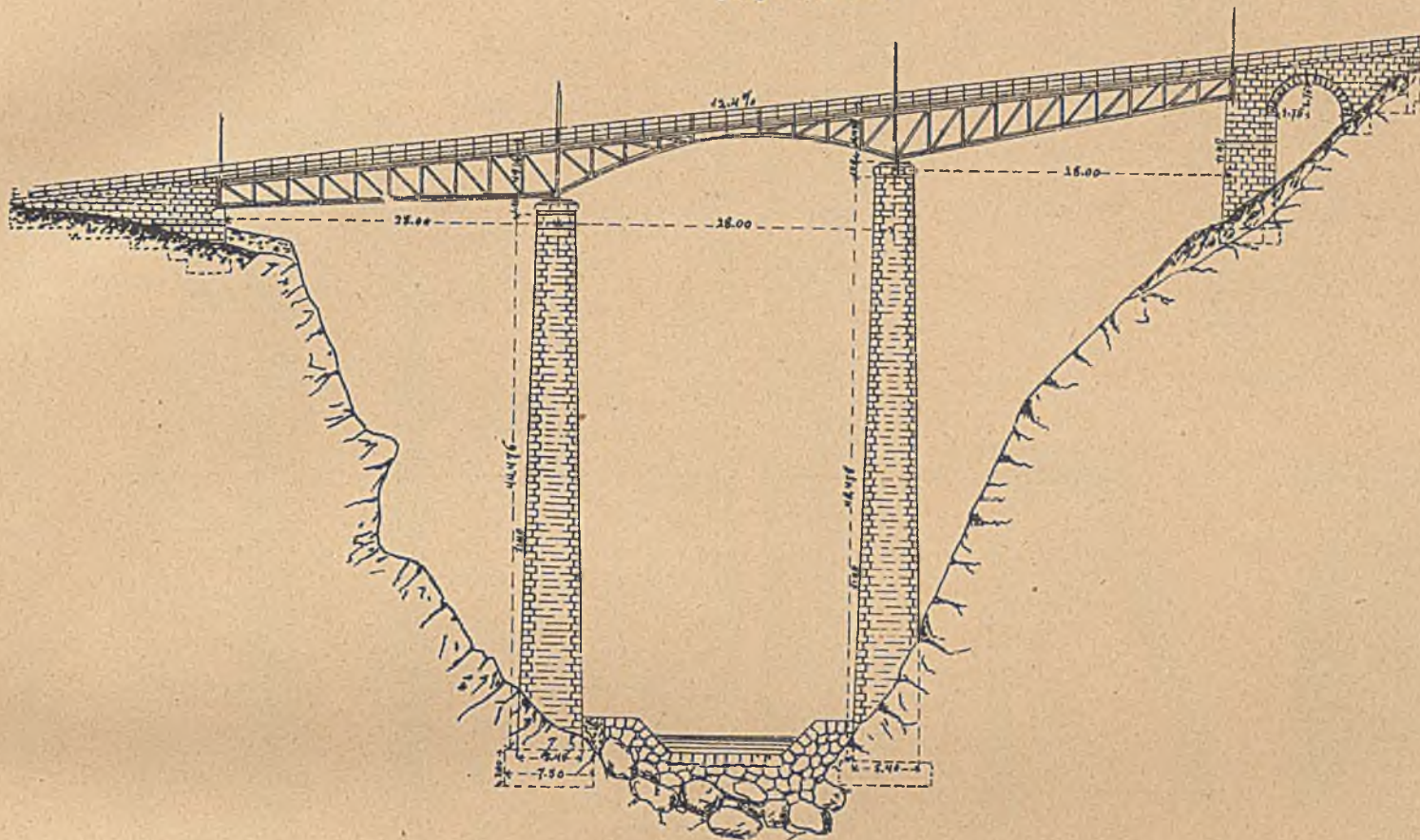

Rys. 2a. Norm. kolei państwowych dla rozpiętości od 15-50 m.

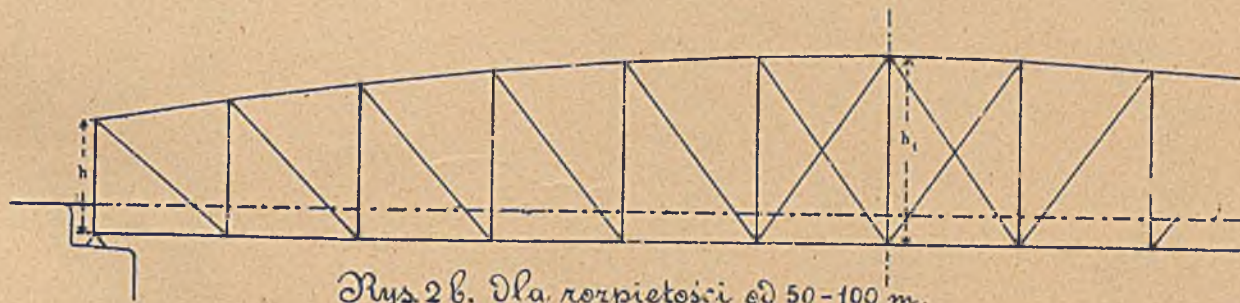

Rys. 2 b. Dla rozpiętości od 50-100 m.

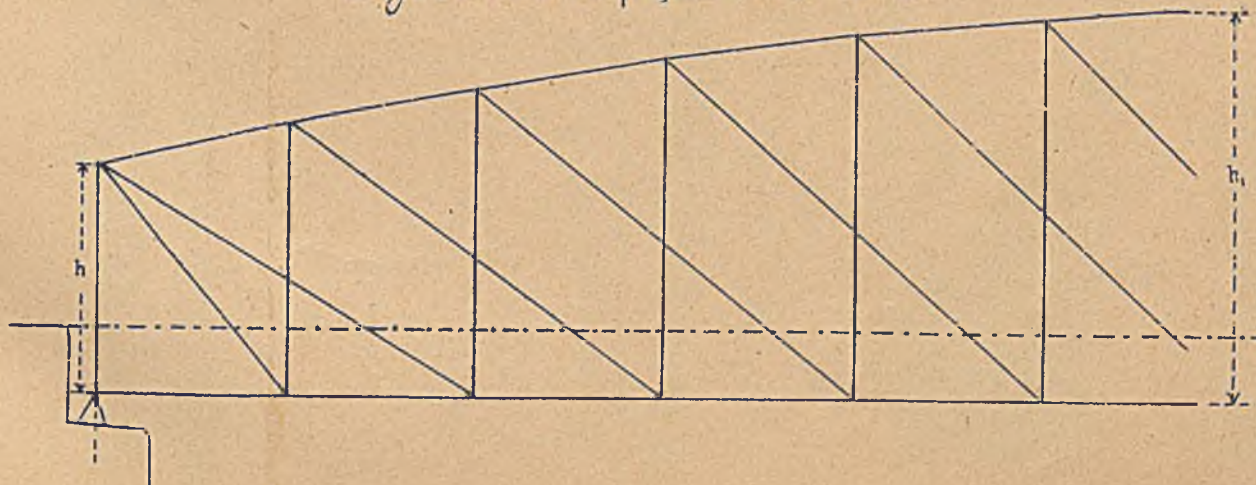

Rys. 1. Nowy most na Drze w Studzienkach.

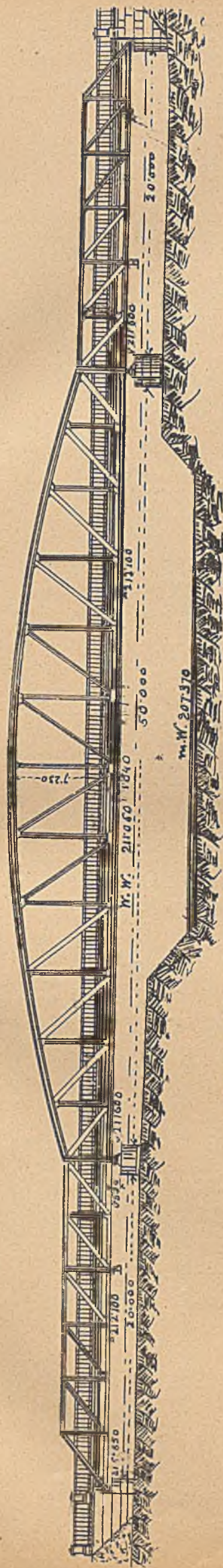

Rys. 2. Most 1680 m. Dł. na rzecze Czerwonej kolei Hanoi - Cbiny.

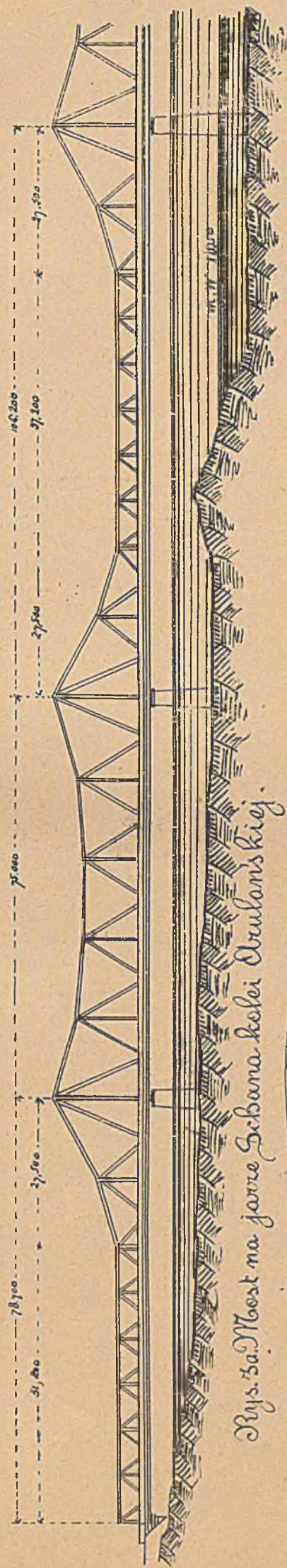

Rys. 3a. Most na jarze Sehana kolei Oulanskiej.

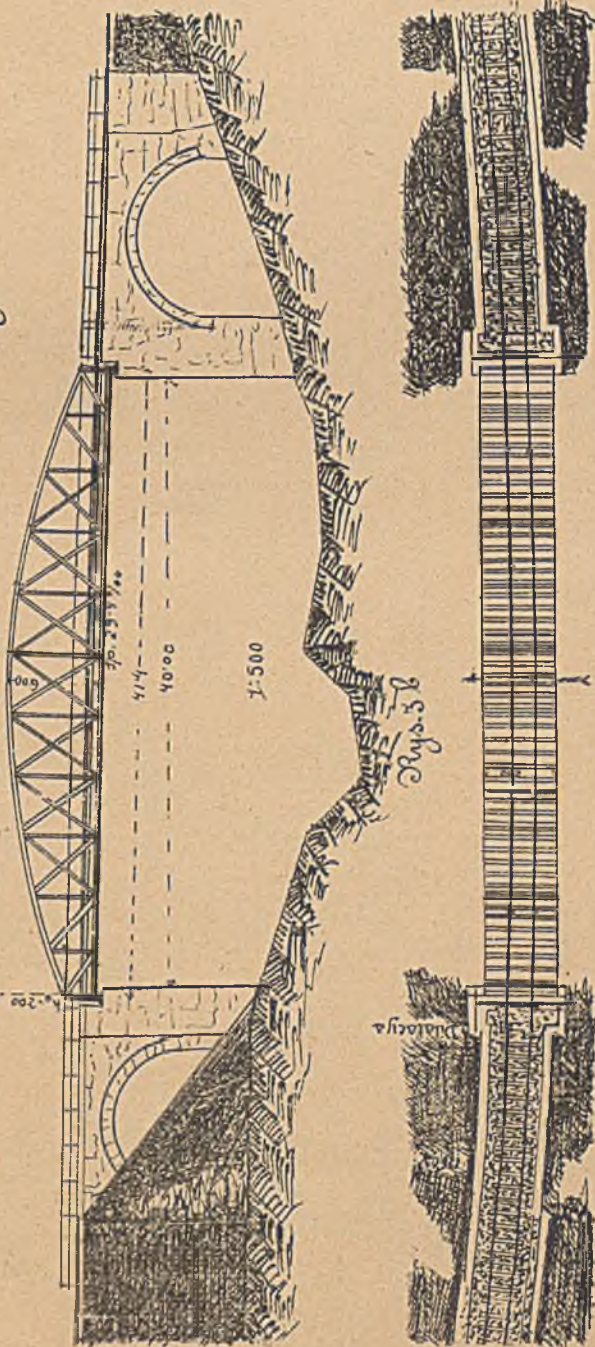

Rys. 4. Most na stacyi Dallos kolei Amulariskij

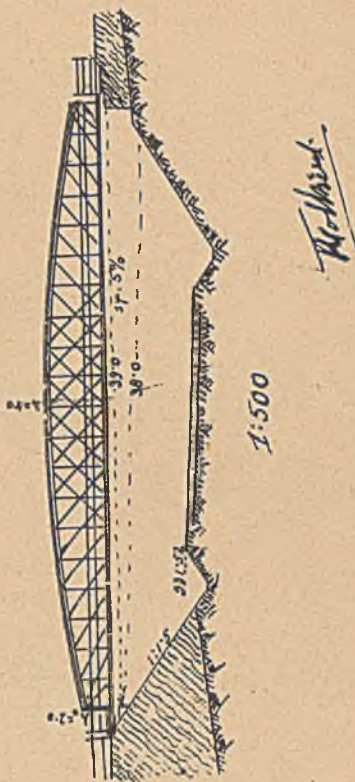

Krata równoboczna.

Rys. 1. Most na rzece Hernardzie w Abos.
kolei Koszycko-Bogumińskiej.

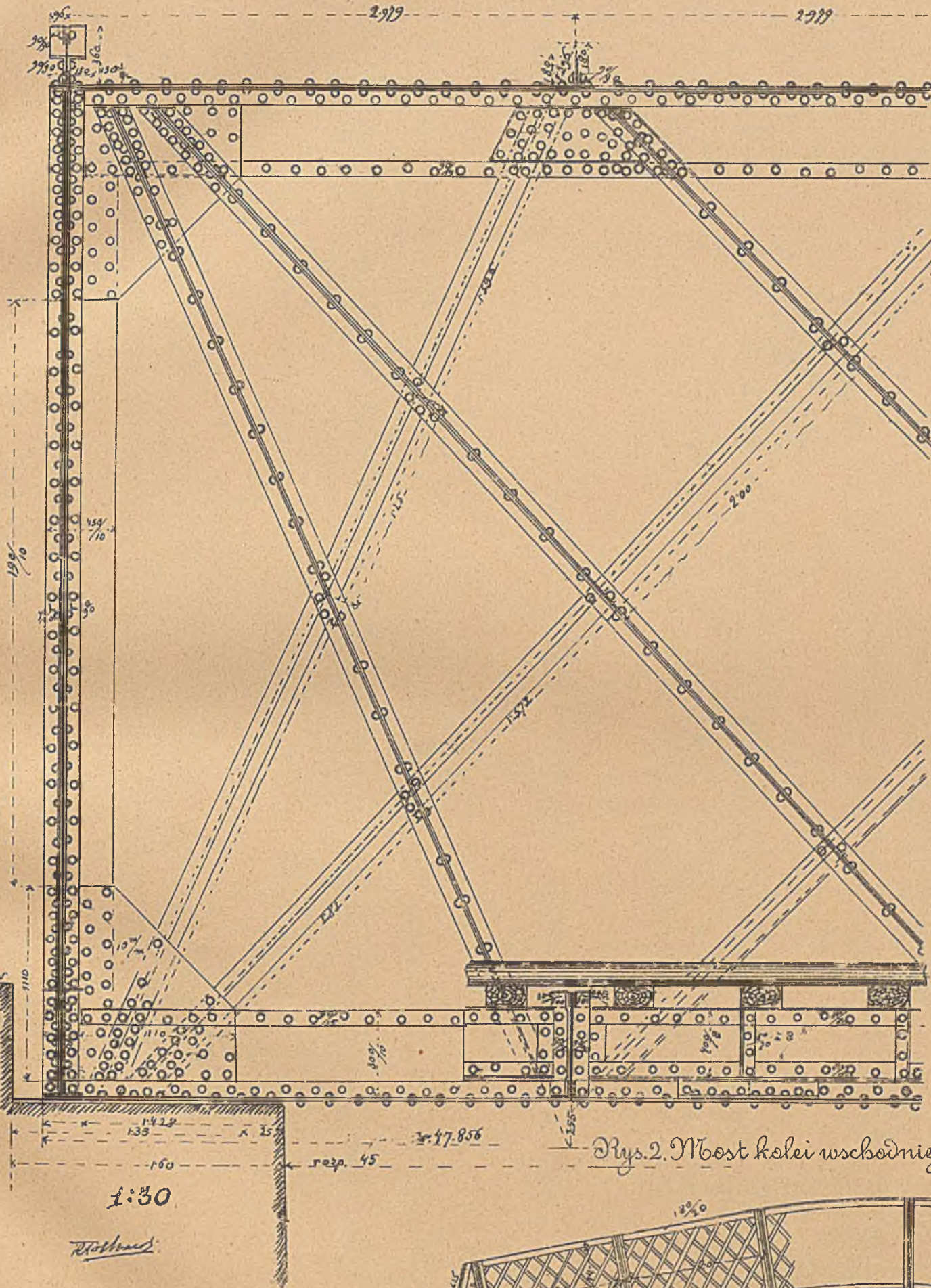

Rys. 2. Most kolei wschodniej angielskiej.

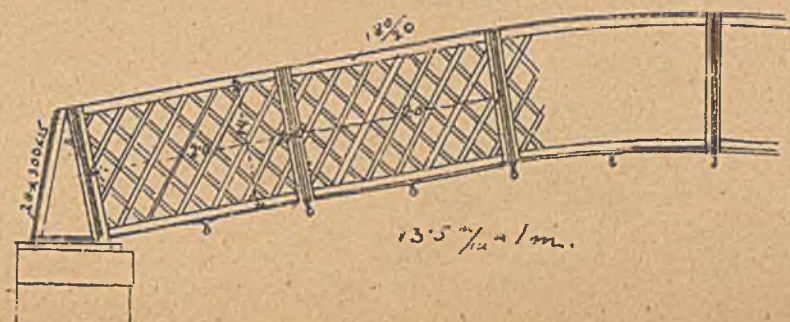

Rys. 1. Most na rzecze Charente we Francji.

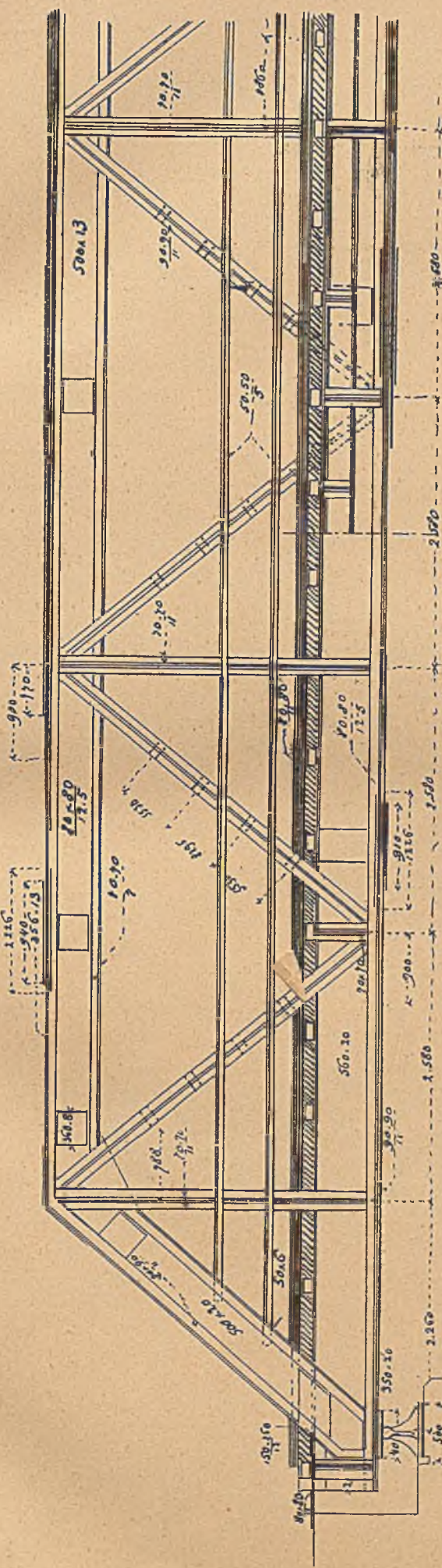

Rys. 2. Most na rzecze Anouère w Monney we Francji.

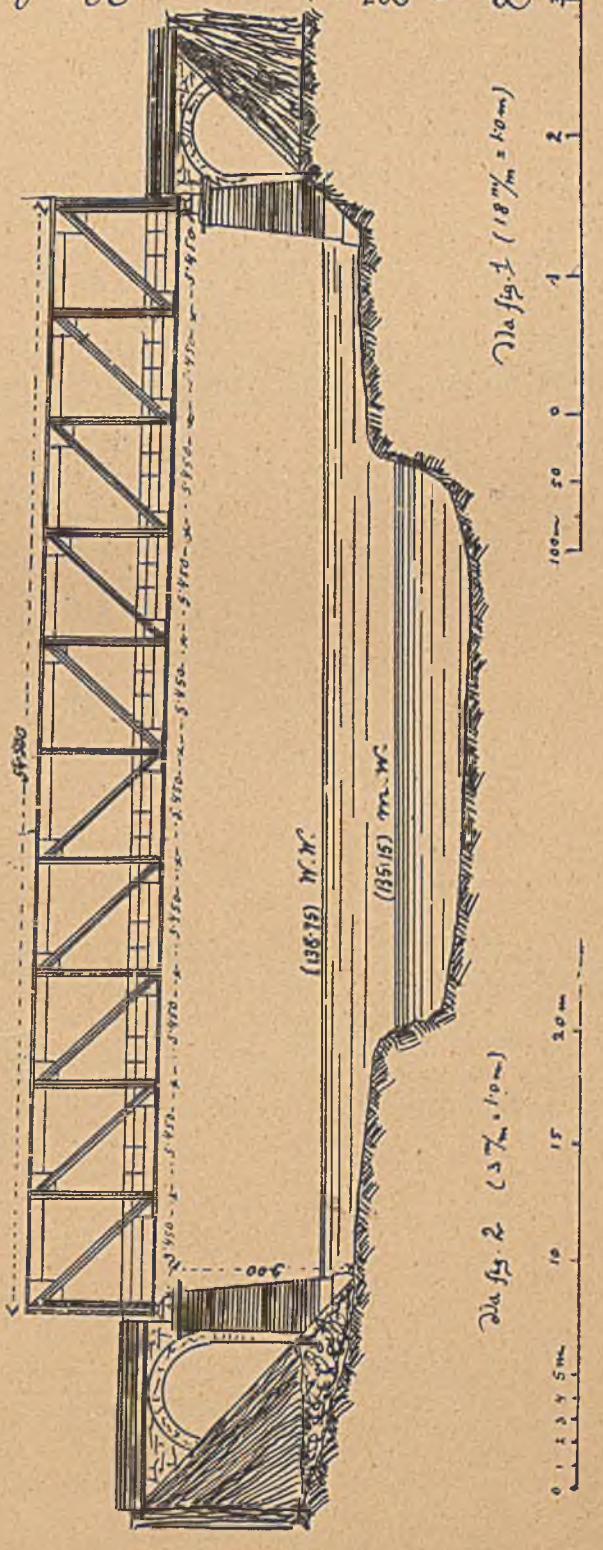

Rys. 3. Most na rzecze Skainfield.

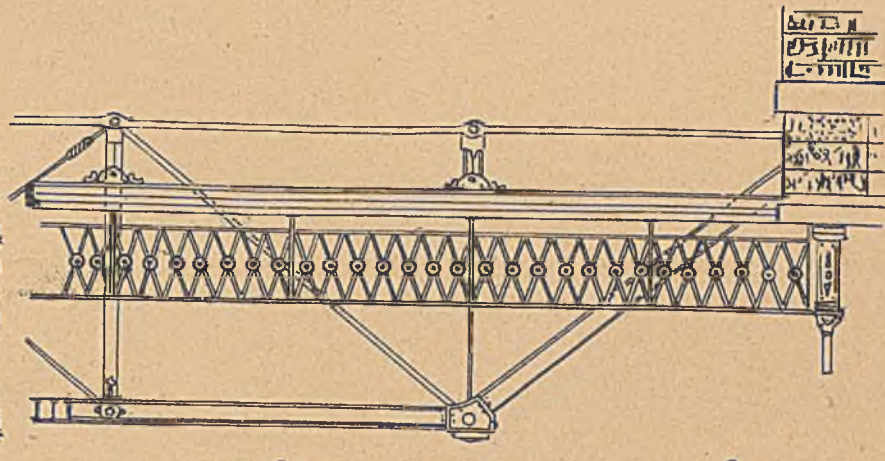

Krata równoramienne.

Rys. 1. Most na Cieranance kolei Korycko-Bogumínskiej.

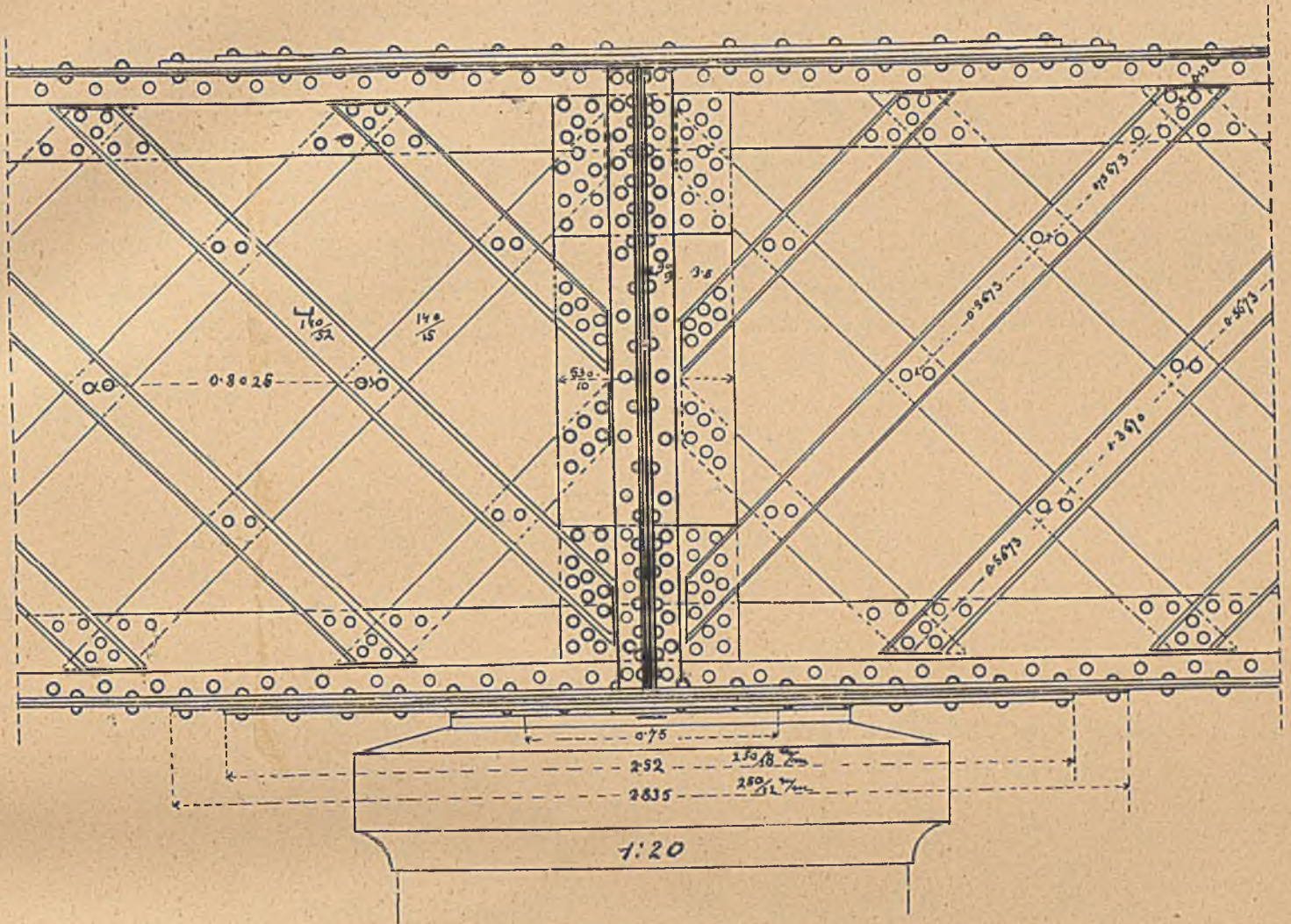

Rys. 2. Most na Słowence w Krompach kolei Korycko-Bog.

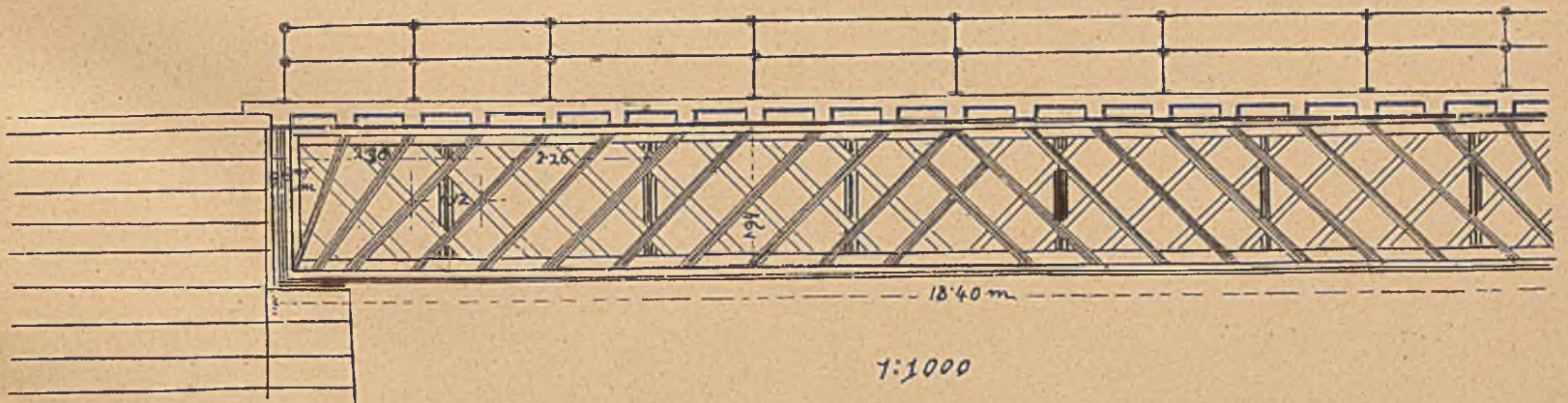

Rys. 3. Mosty włoskie.

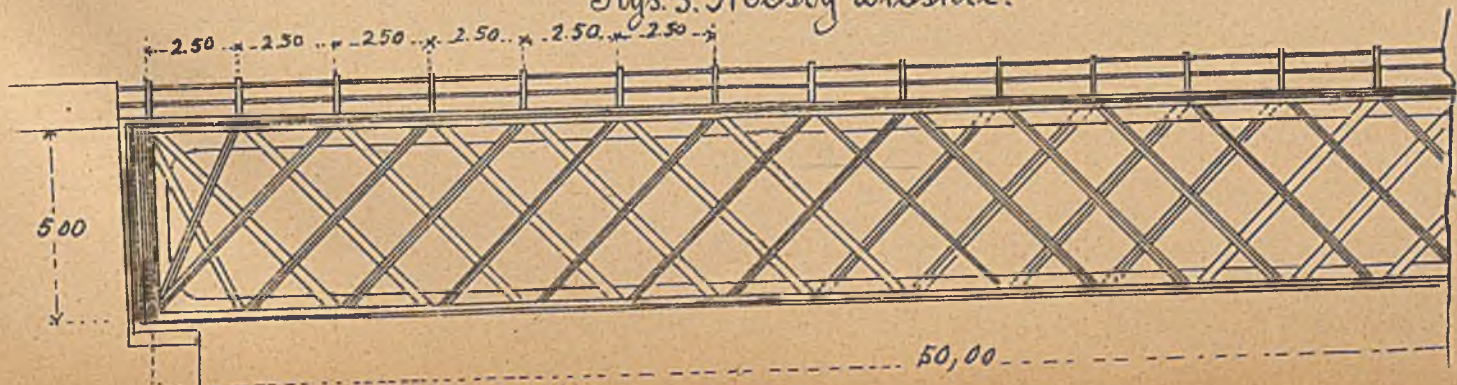

Rys. 1. Most w Rocheckiem.

Skala: $\frac{8\text{mm}}{1\text{m}}$.

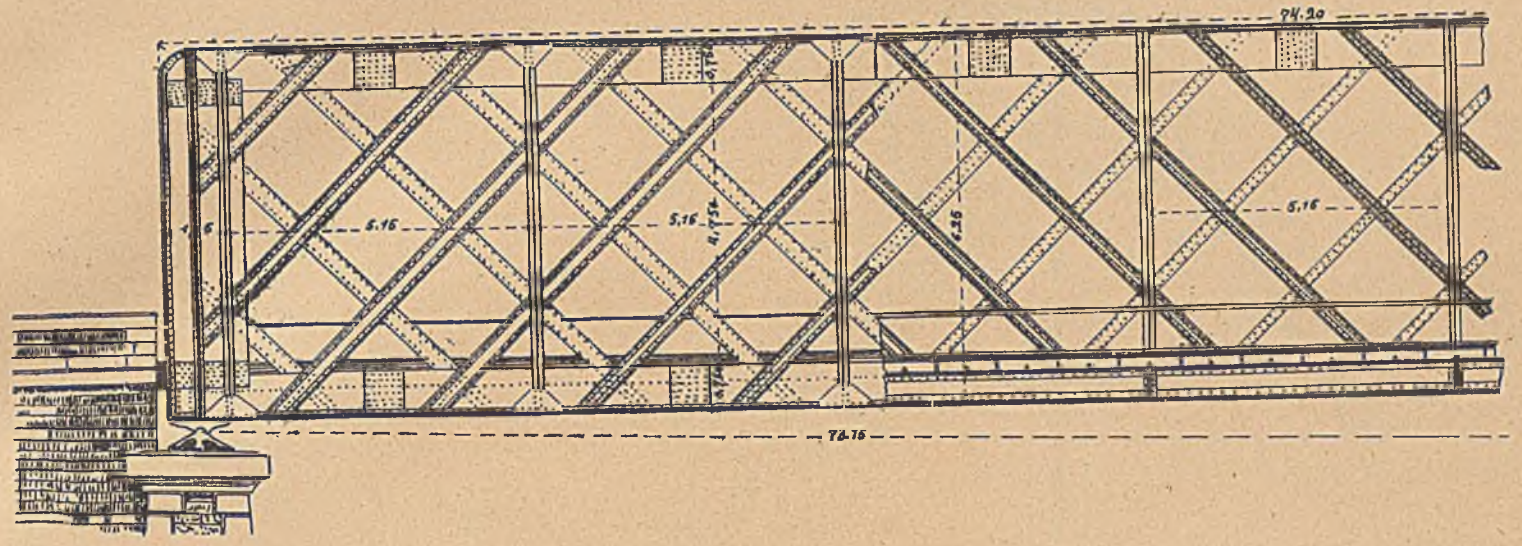

Rys. 2. Most na Hernadrie pod Abos.

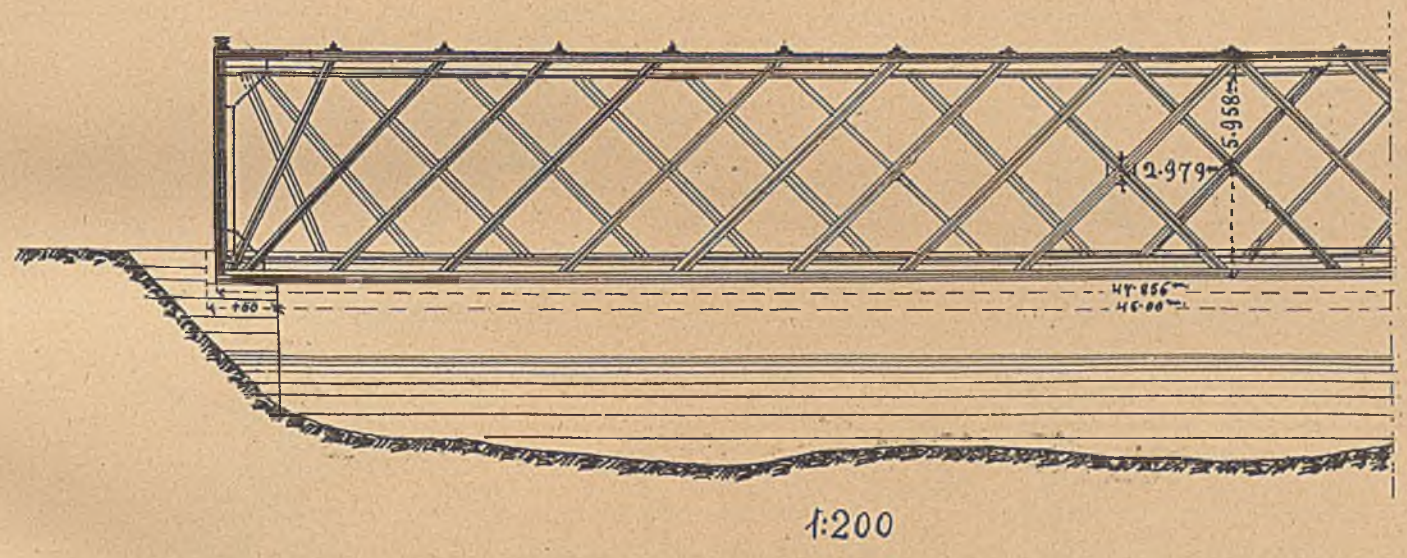

Rys. 3. Most na Cernance.

1:200

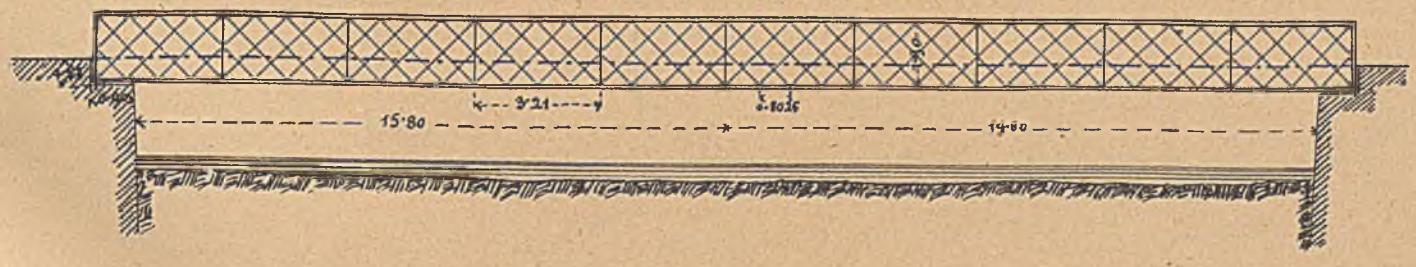

Cieżar zelaza 872 kg/m.
 " pomostu 454 kg/m.

Kratarównoramienna.

Rys. 1. Most włoski.

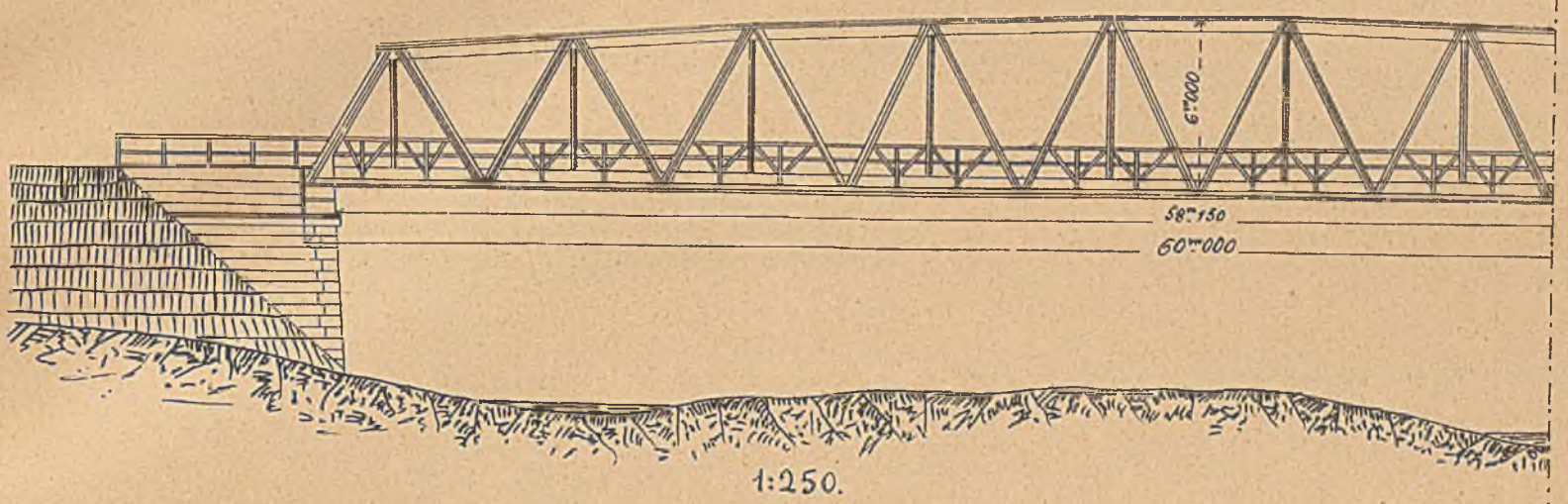

Rys. 2. Most na Hernadric w Margerariack.

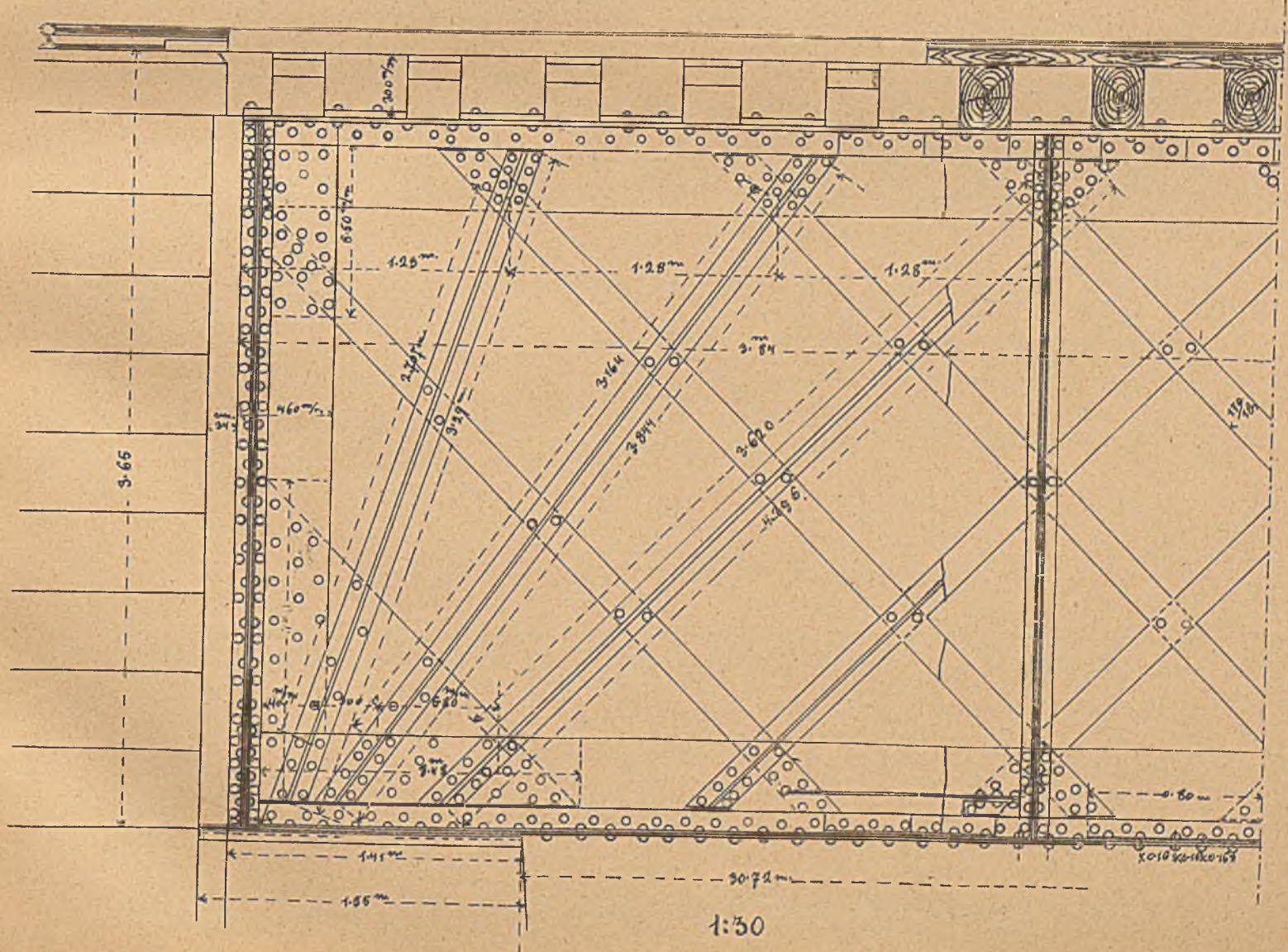

Krata równoramienna.

Rys. 1. Most na Arwis.

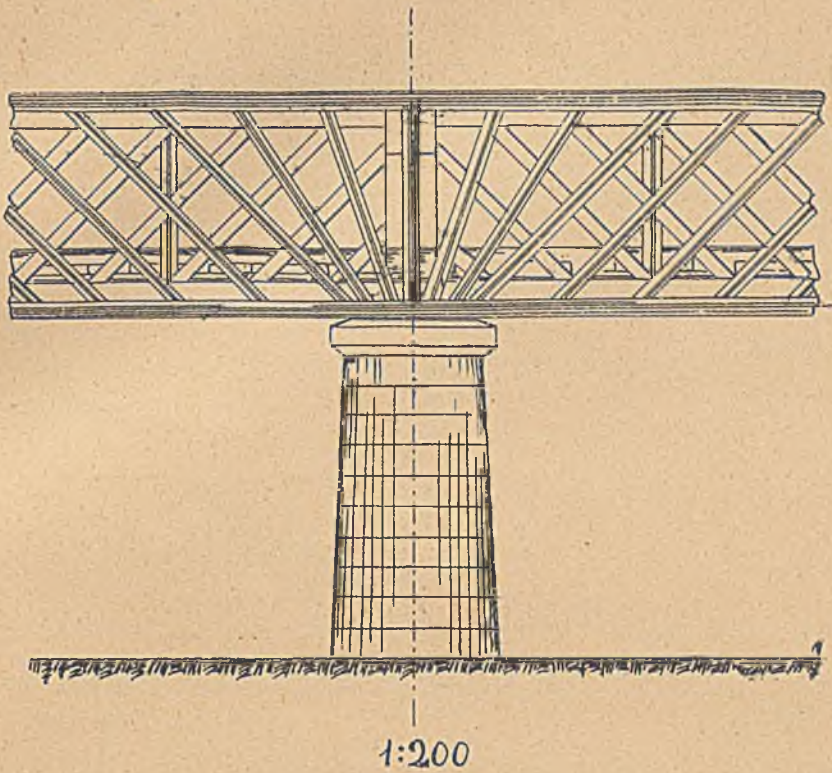

Rys. 2. Most w Hellenburg nad ul. Singlair

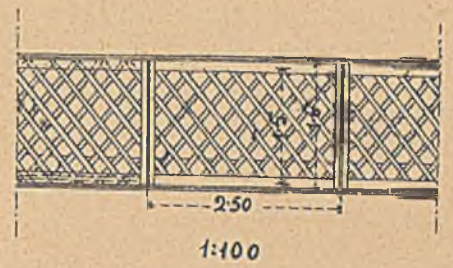

Rys. 3. Most na Marnie między St. Mawr i Bonneuil.

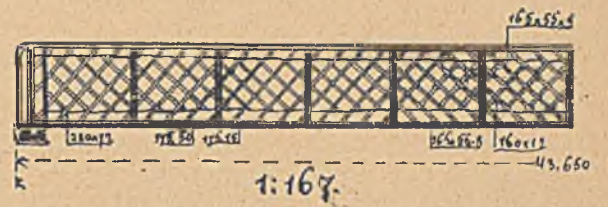

Rys. 4. Wiadukt na Sekwanie w Manceur.

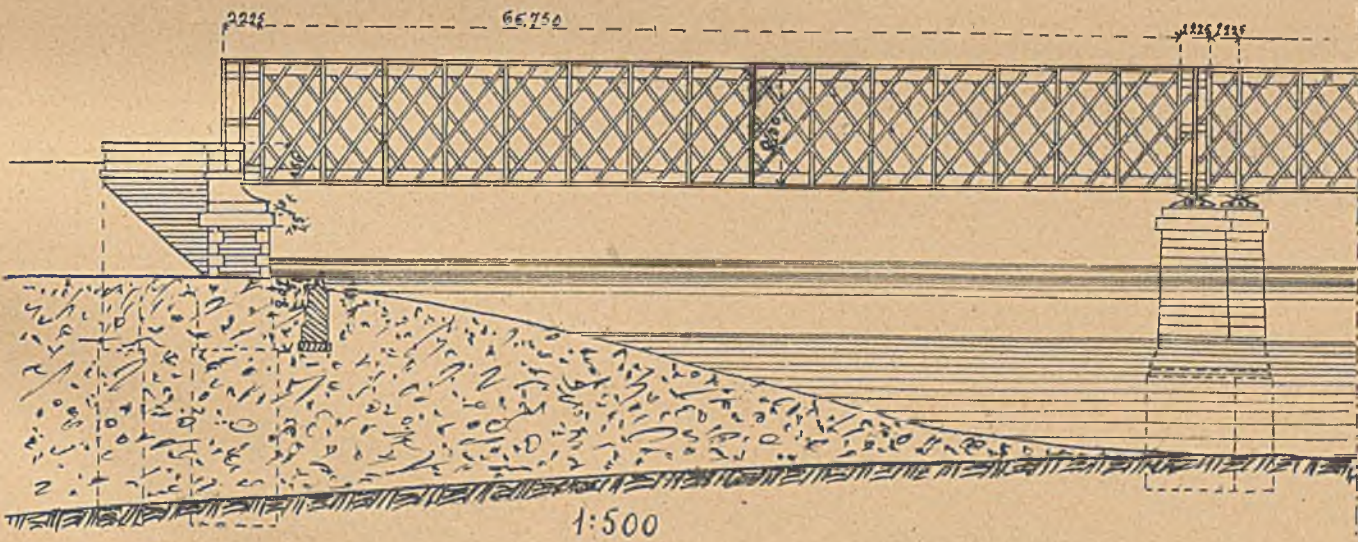

Rys. 5. Most na kanale Manches terskim.

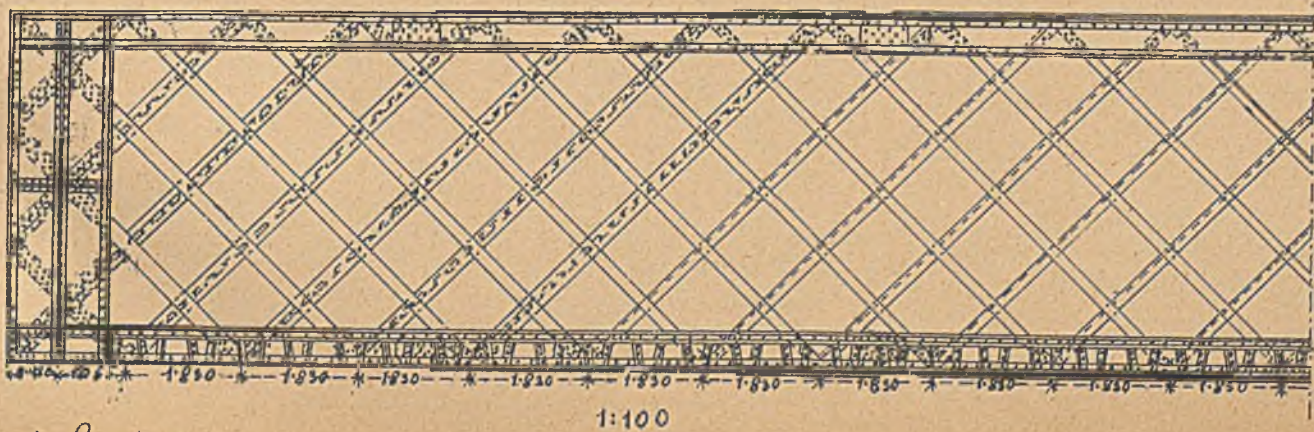

Krata i pasy.

Rys. 1. Most Orleaniski w Saryju nad ulica, Legendre.

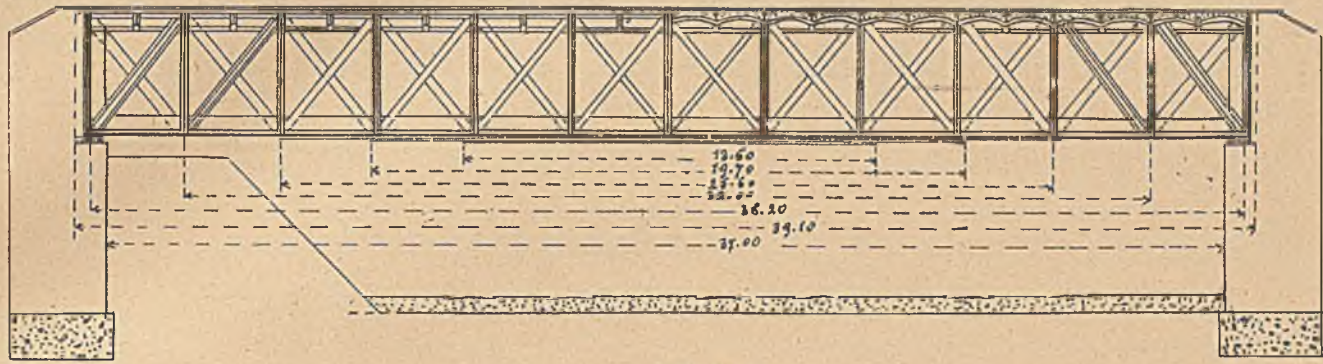

1:250

Rys. 2. Most pod Wertbenstein.



Rys. 3. Most w Diege.

1:400



Rys. 4. Most na Rodach kolei Flochstadt - Storkheim.

Widok

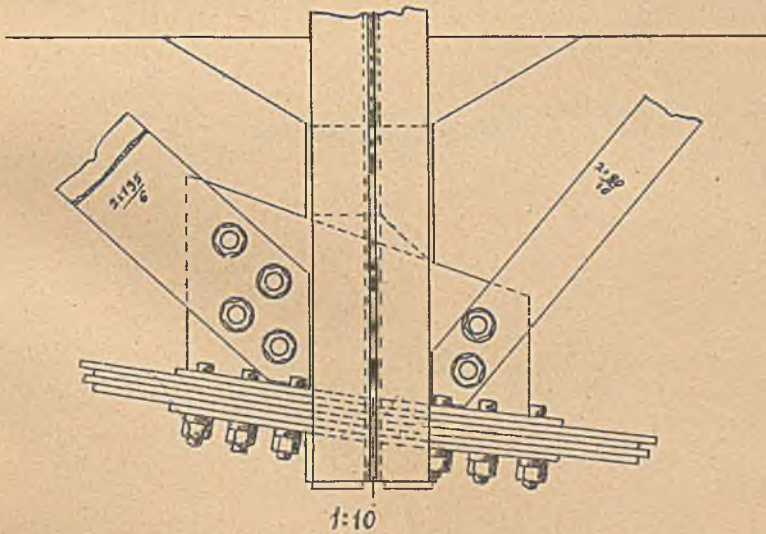

Strzałkowy

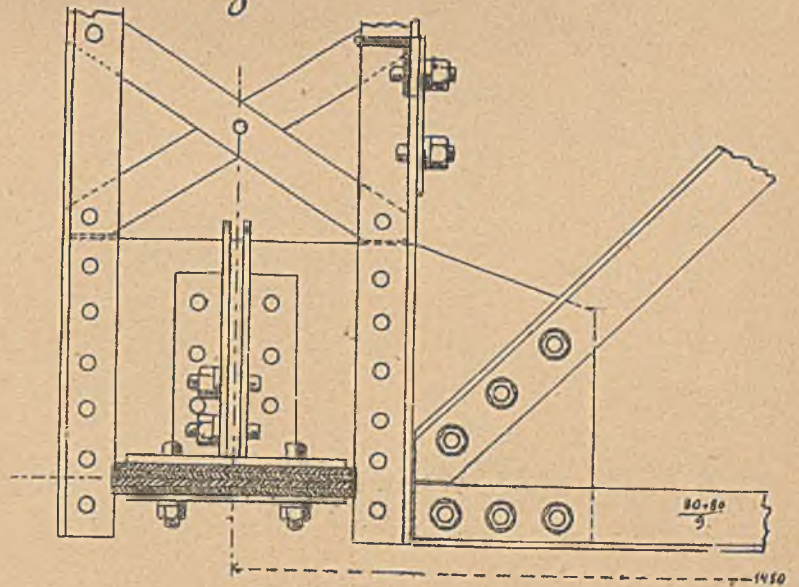

Rys. 5. Most na Trarre pod Blatting.

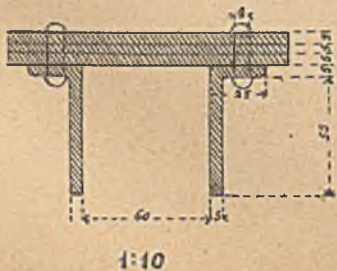

Rys. 6. Most na Dunaju pod Rechtenstein.

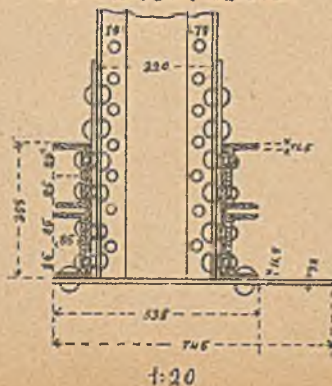

Rys. 7. Most na Süderalbe pod Harburgtem.

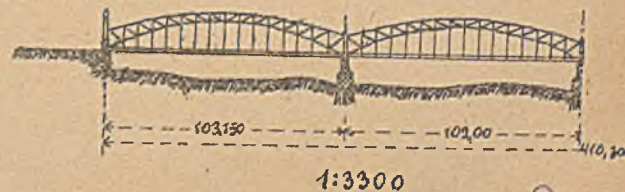

Rys. f.d.

Rys. 1. Most Fairbairna St. Louis.

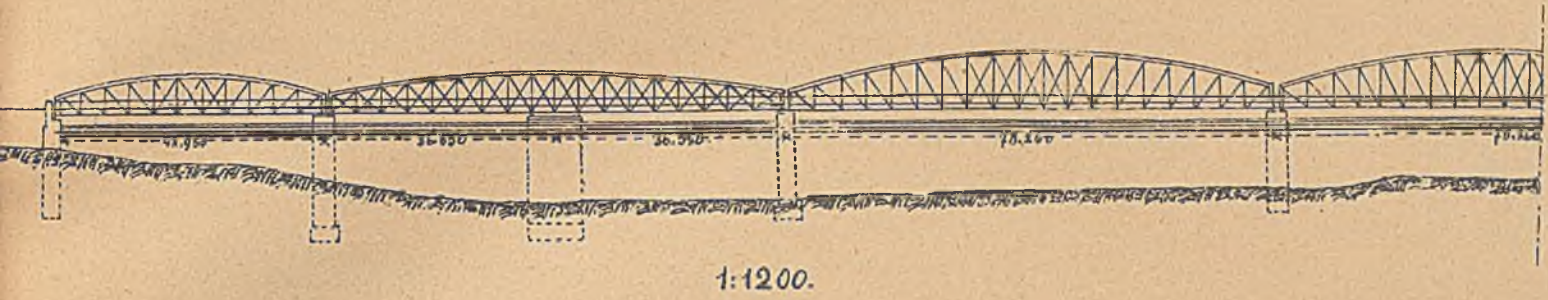

Rys. 2. Most na Renie kolei Albula pod Tibusis.

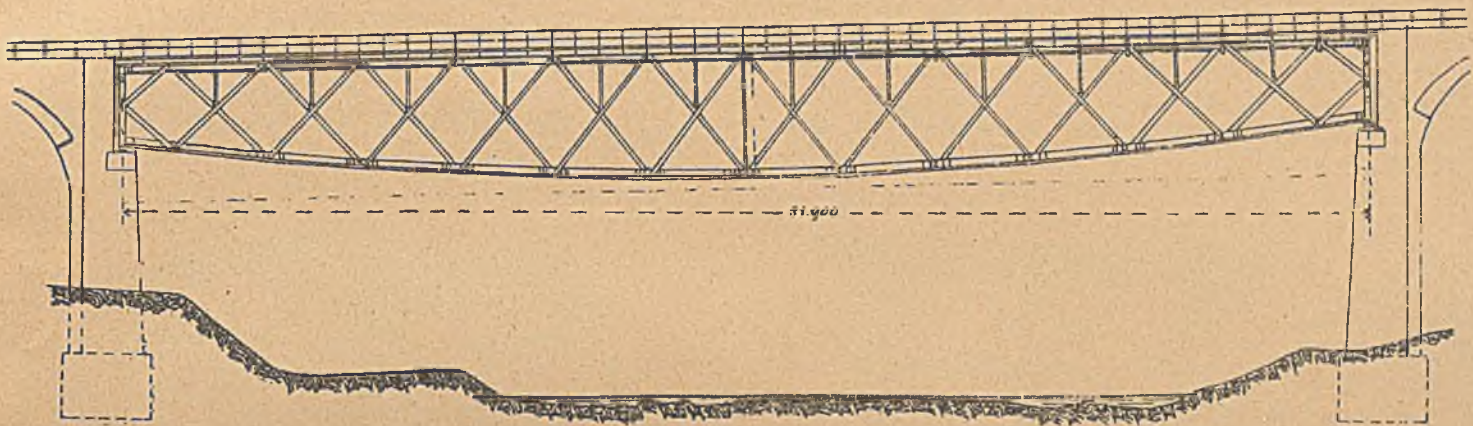

Rys. 3. Most na Nye pod Chepstow.

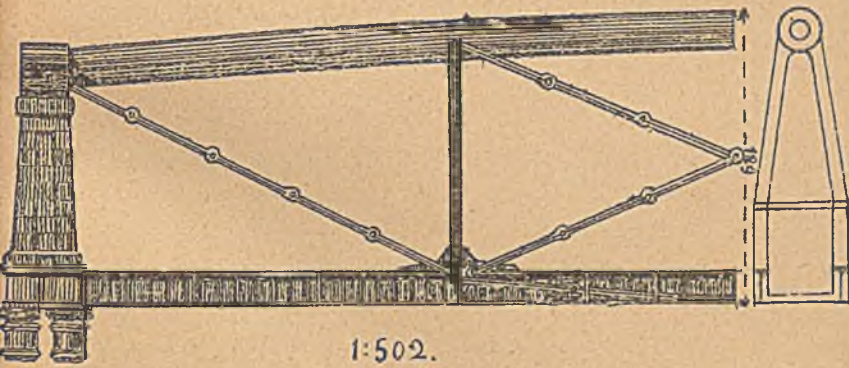

Rys. 4. Most pod Saltasb.

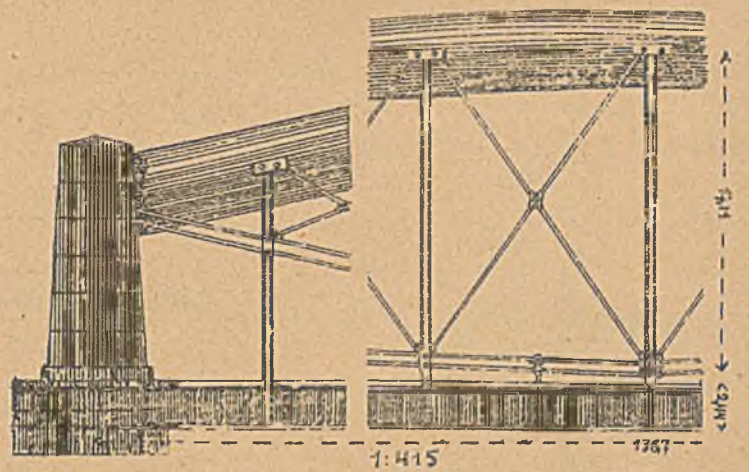

Rys. 6. Most na Bialej.

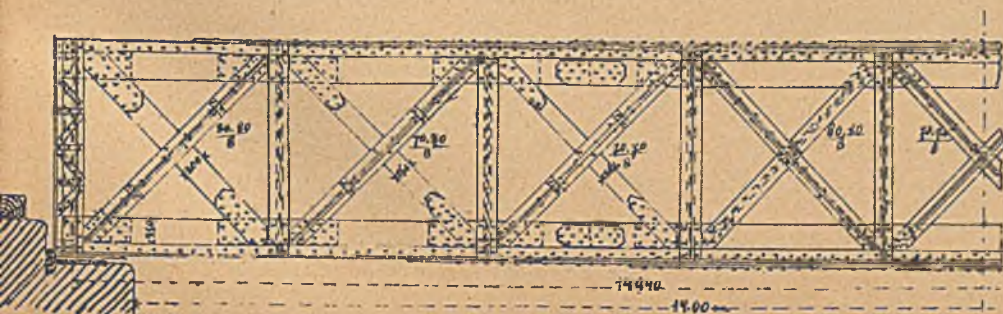

Rys. 7. Most na Kanale w Biluelu pbi.

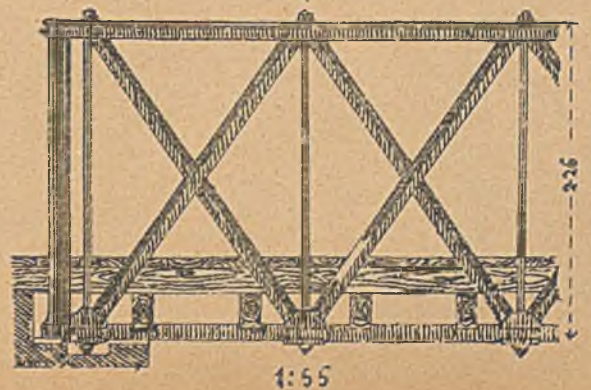

Pasy.

Rys. 1. Most kolei lokalnej
d'Angoulême a Rouillac.

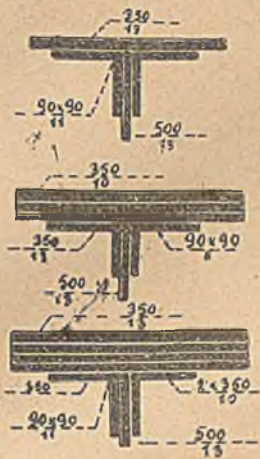

Rys. 2. Most na Tynie Kolei Banista

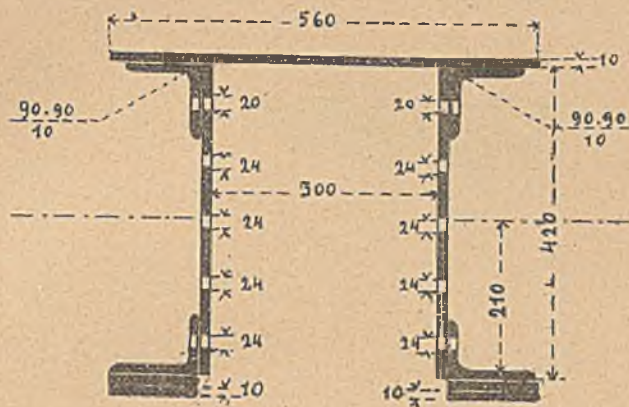

Rys. 3. Most k' Wiedniu
kolei Glibisty

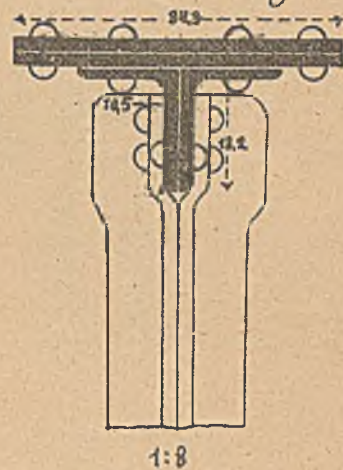

Rys. 4. Most na Dnieprze w Brestu.

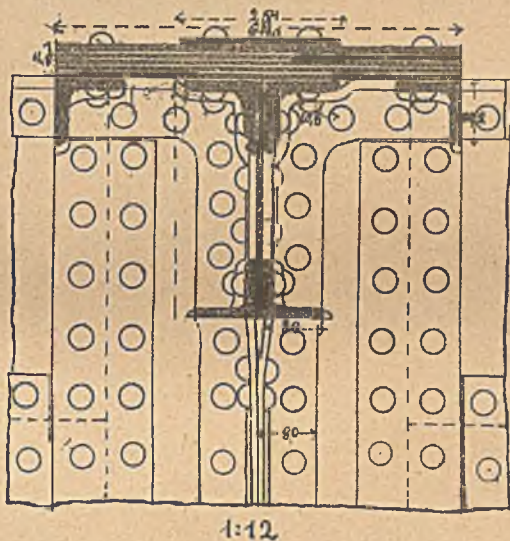

Rys. 5. Most na Garonnice w Langon.

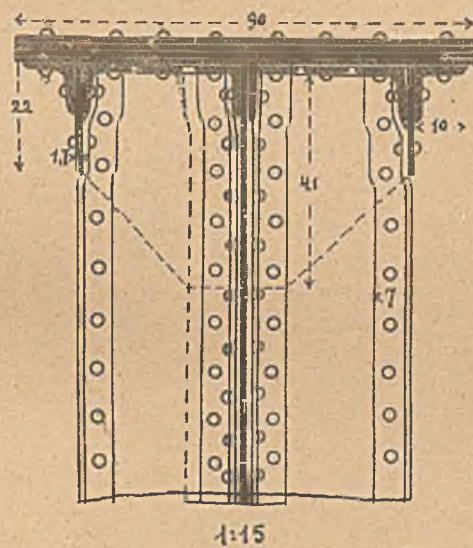

Rys. 6. Most na Renie
w Grieshausen.

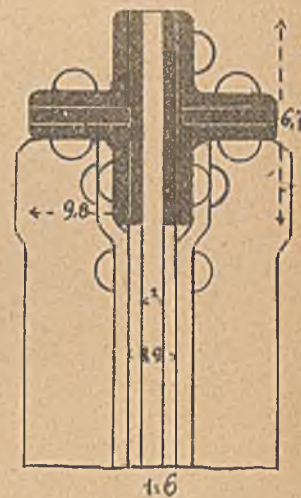

Rys. 7. Most na Renie pod Moguncya

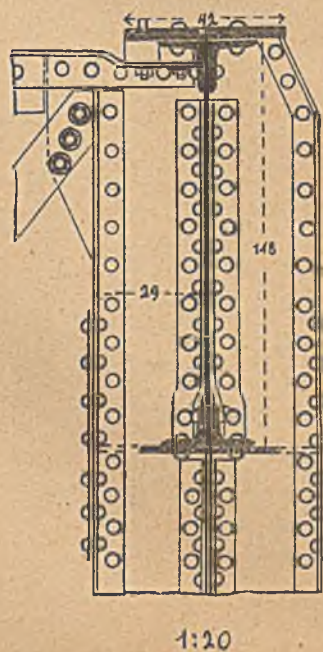

Rys. 8. Most Skarmon

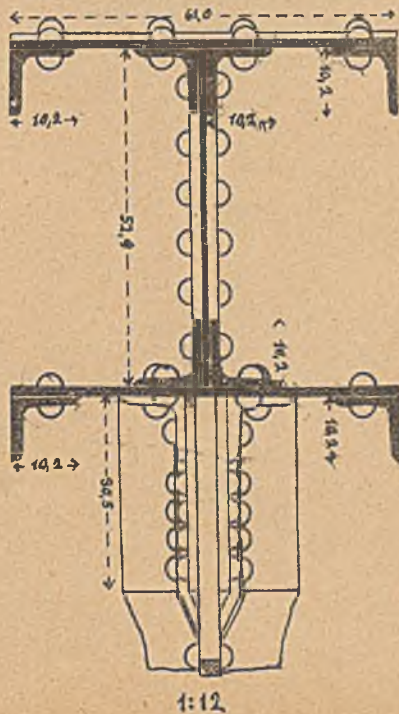

Rys. 9. Most na Tamizie w Windsorze

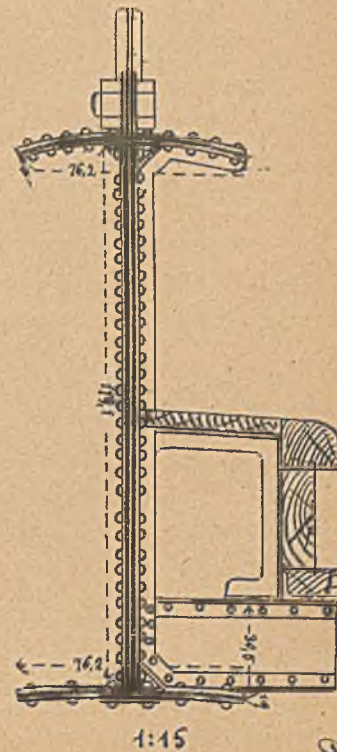

Basz.

Rys. 1. Most na Renie w Moguncji

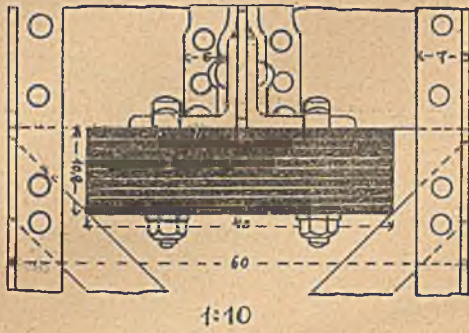

Rys. 2. Małe mostki

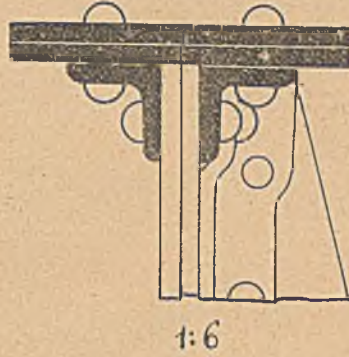

Rys. 3. Kolej szwajc. centralna.

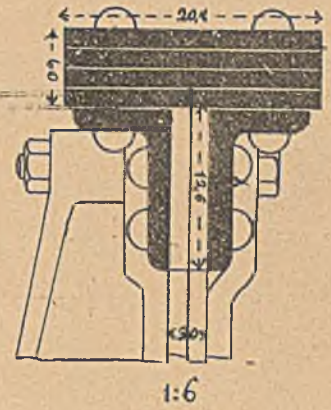

Rys. 4. Urząd zwykły



Rys. 5. Most na Renie w Waldsbu. Rys. 6. Most kolei Rudol

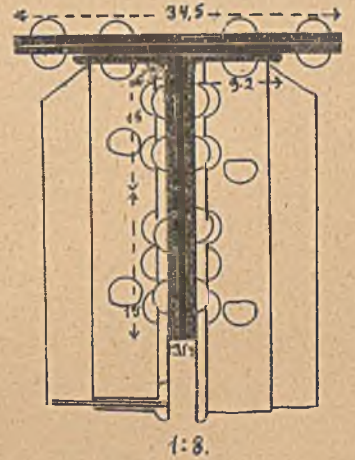
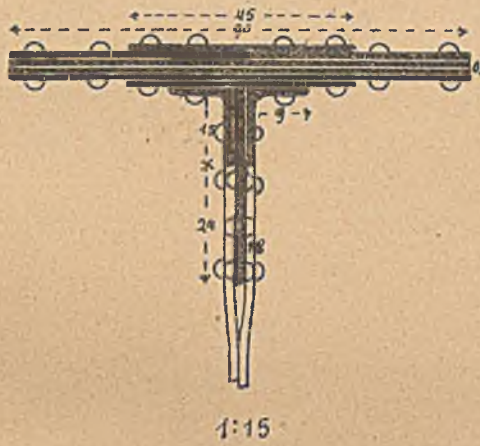

Rys. 7. Most na Dunaju w Stadlau

Rys. 8. Most na Renie w Kebl. Rys. 9. Kolej austri. połud.

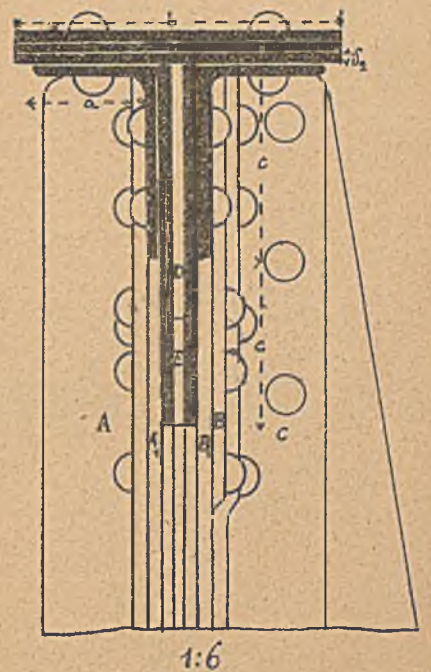
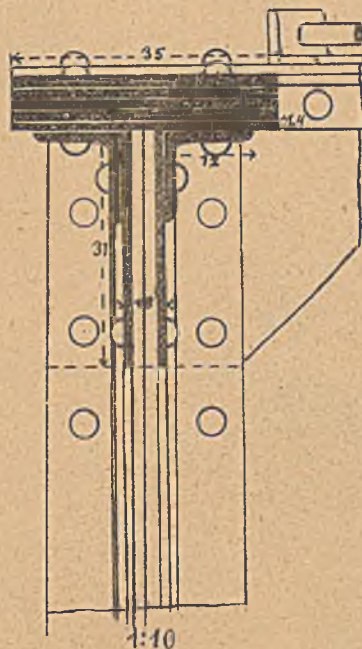
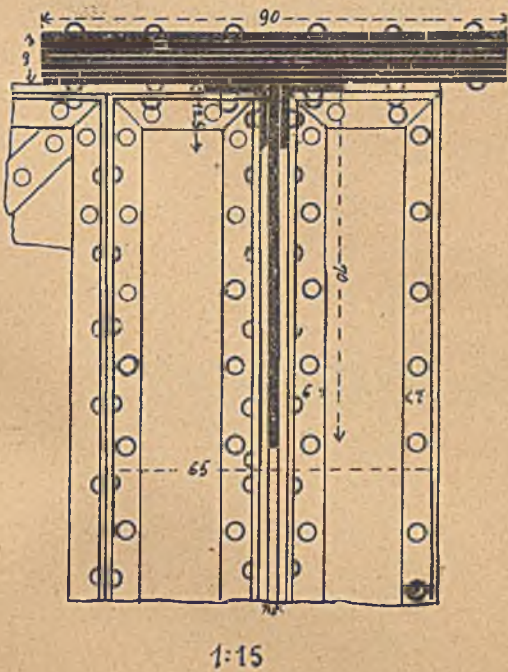

Rys. F. G.

Bazy.

Rys. 1. Most na Elbie pod Weissen

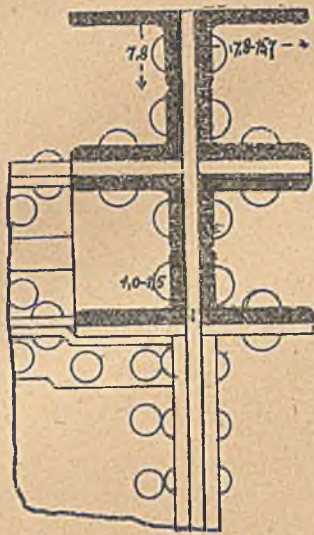

1:8

Rys. 2. Most na Wiśle pod Dirschau.

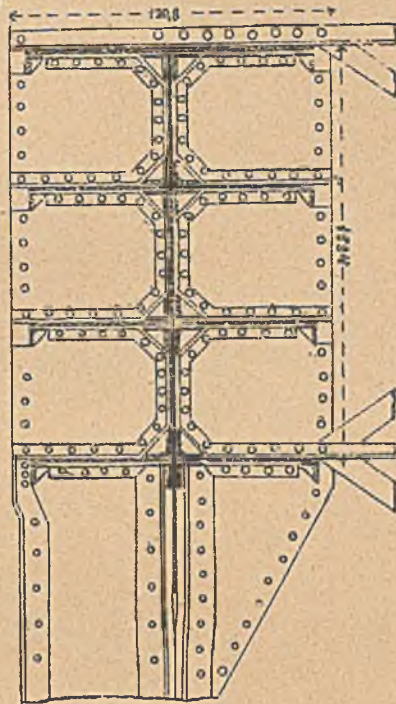

1:53

Rys. 3. Most na Renie w Kolonii

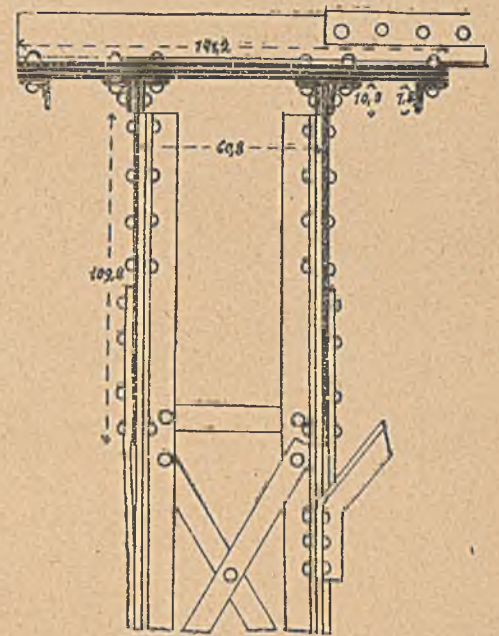

1:25

Rys. 4. Most pod Labenstein

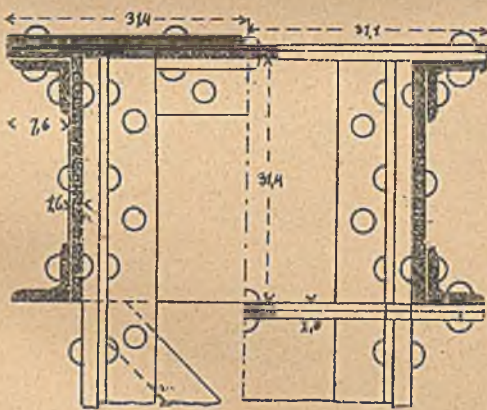

1:10

Rys. 5. Viadukt w Kleparowie pod Lwowem.

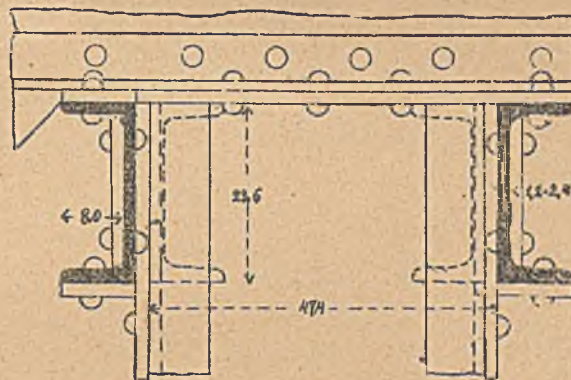

1:10

Rys. 6. Most w Wrocławiu

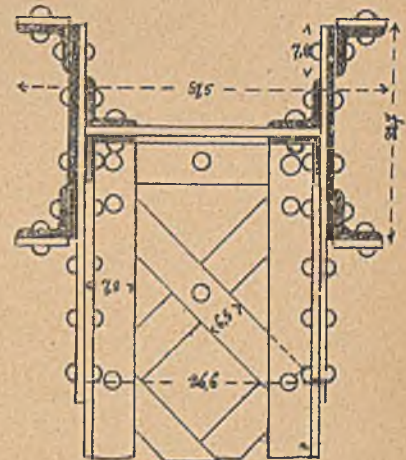

1:12

Rys. 7. Most w Londynie.

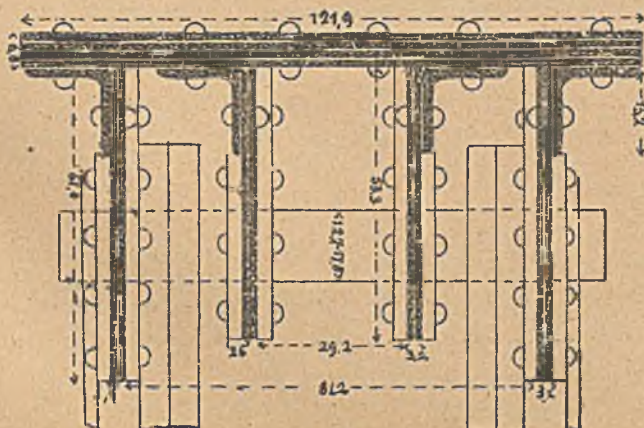

1:15.

Rys. 8. Most pod Blackfriars.

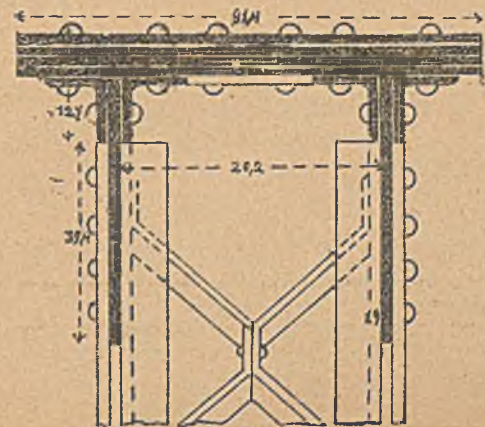

1:16.

Rys. 7. S.

Bełki wieloboczne.

Rys. 1.



Rys. 2. Most pod Klassefurtam na Mben

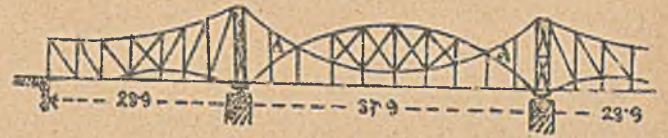

Rys. 3. Most na Narcie w Bernanie

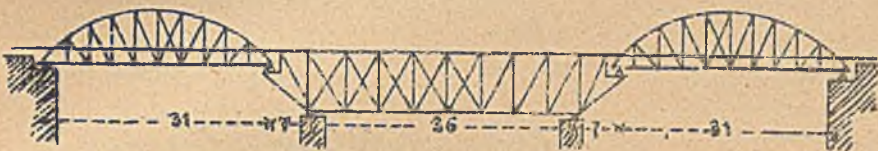

Rys. 4.



Rys. 5. Most na zatoce Dork w Anglii

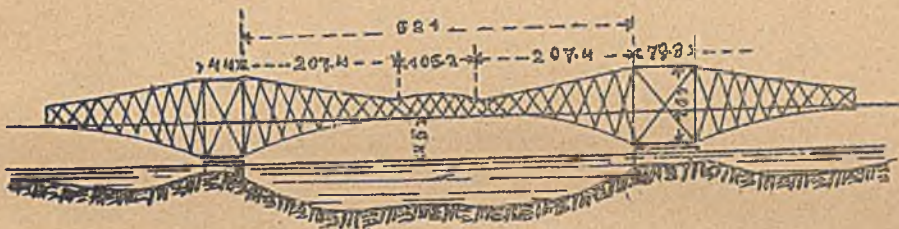

Rys. 6.

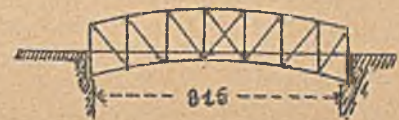

Rys. 7. Most nad Indem pod Sukkur.

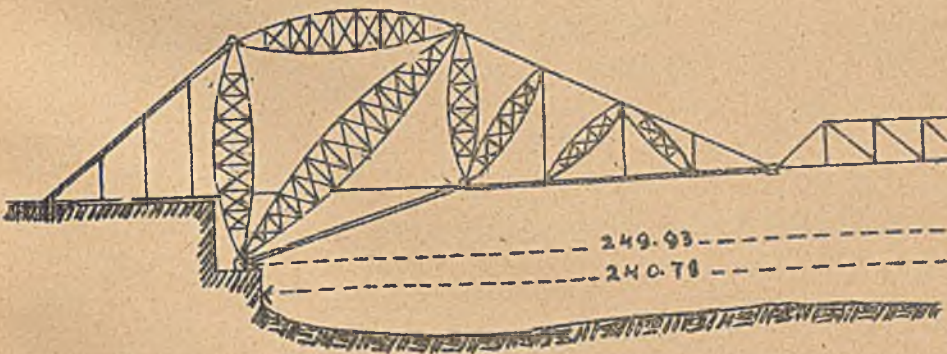

Rys. 8.



Rys. 9. Most na Dunaju pod Cernowoda,

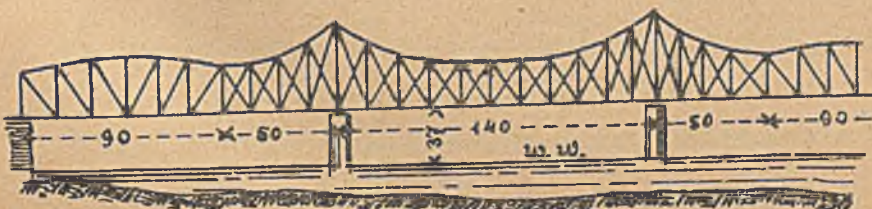

Rys. 10.



Rys. J. D.

Rys. 1.



Rys. 2.

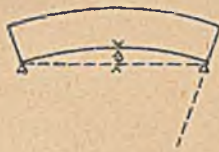

Rys. 3.

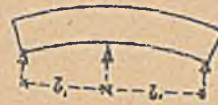

Rys. 4.



Rys. 5 a.



Rys. 5 b.

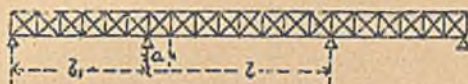

Rys. 6.

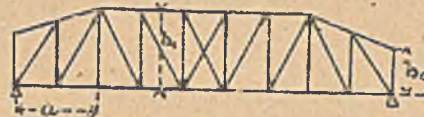

Rys. 7.

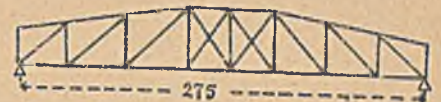

Rys. 8.



Rys. 9.

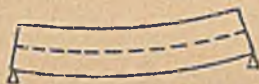

Rys. 10.



Rys. 11.

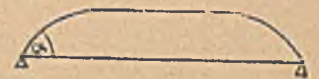

Rys. 12.

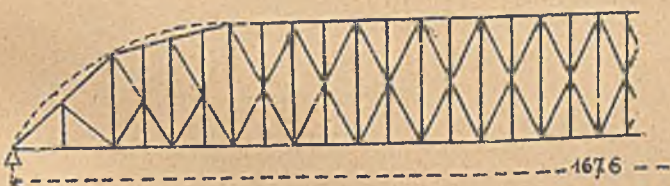

Rys. 13 a.



Rys. 13 b.

Rys. 14.

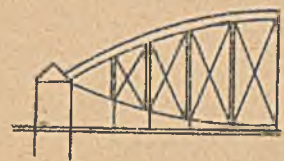

Rys. 15. Projekt mostu na Kanale La Manche.

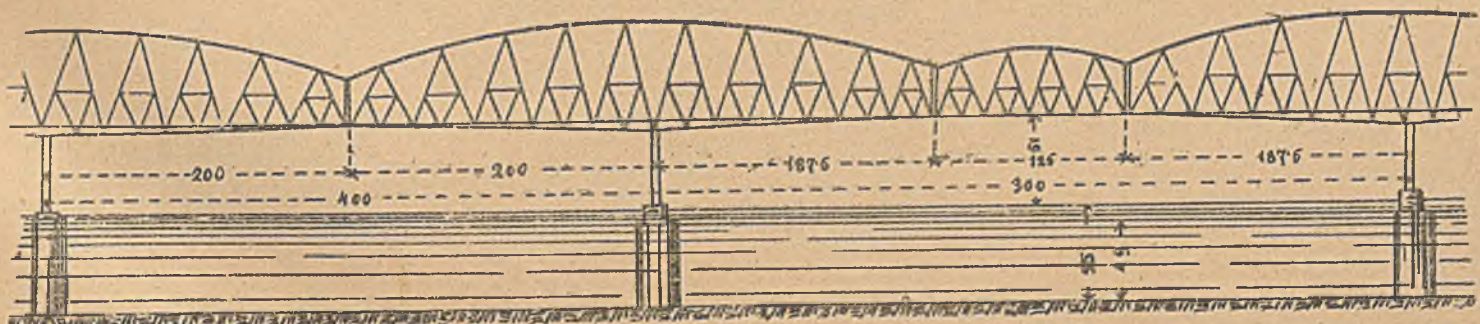

Rys. 15.

Kształt belek głównych

Rys. 1. Most na Hudsonie w New-Yorku

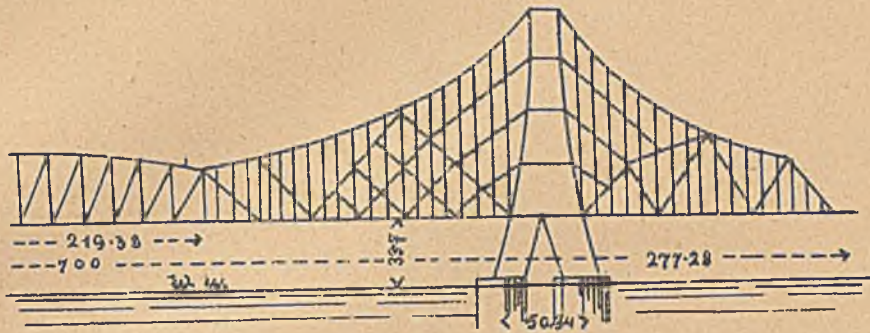

Rys. 2a. Odstęp kryżulców i nachylenia



Rys. 2 b.



Rys. 2 c.



Rys. 3. Most Franciszka Józefa na Dunaju w Peszcie.

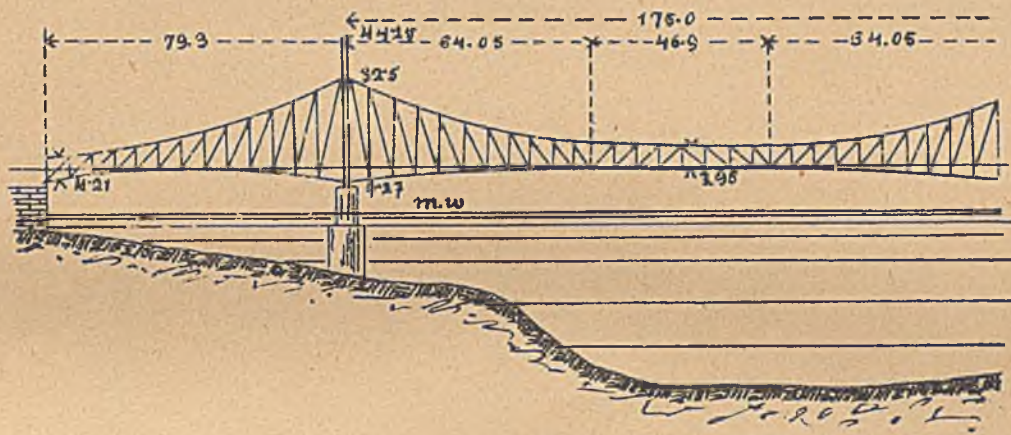

Nachylenie kryżulców

Rys. 4a.



Rys. 4 b.



Rys. 4 c.

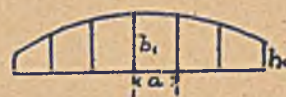

Rys. 4 d.



Rys. 5. Most kolei centr: szwajc.



Rys. 6. Krata koroz radka.



Rys. 7. Most pod Newark nad Trentem.

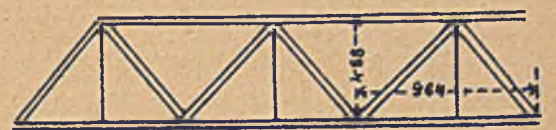

Rys. f. d.

Paryz

Rys. 1. Nowy most na Wiśle pod Screwem.

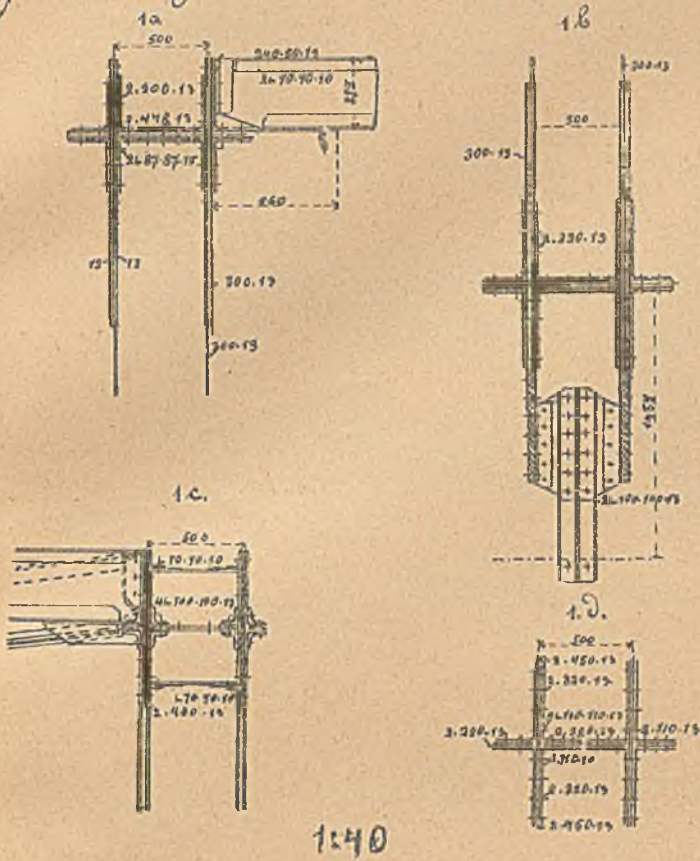

1:40

Rys. 2. Most na Tamizie w Charing-Cross.

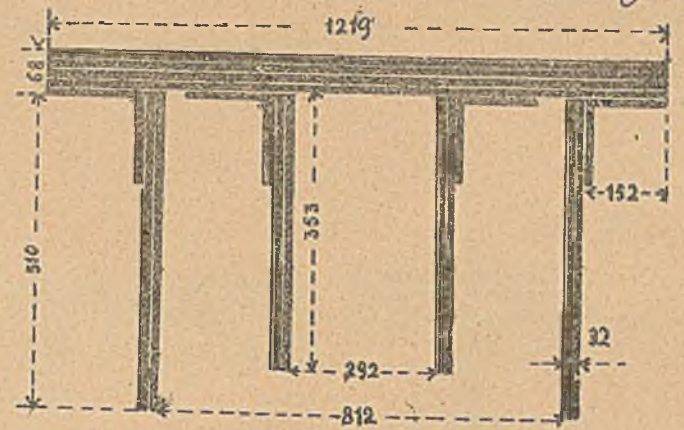

Rys. 3. Most pod Czernawodą na Dunaju.

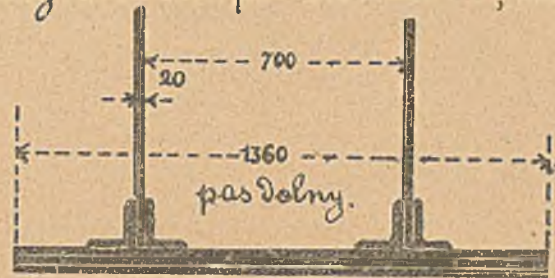

Rys. 4. Przekroje amerykańskie.

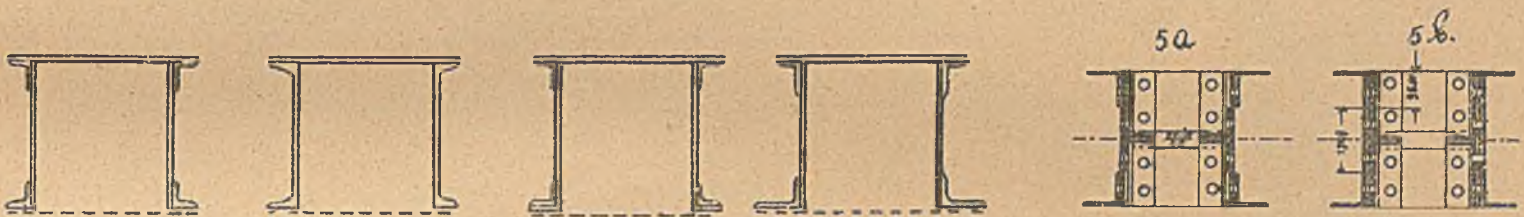

Rys. 5. Most na Dreze w Studrienkach.

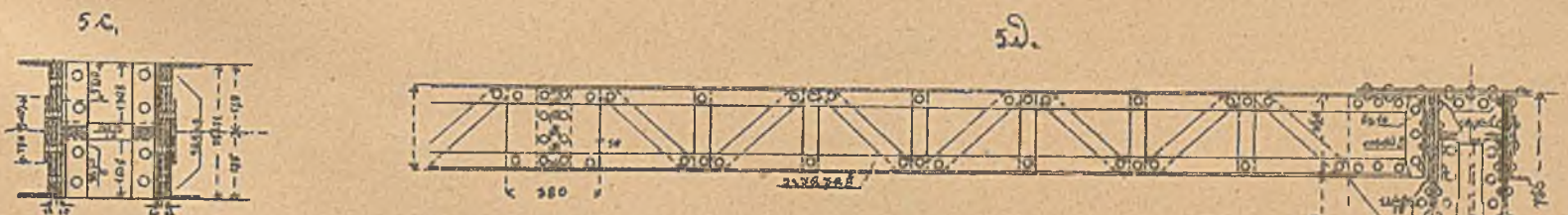

Rys. 6. Most Mirabeau na Senie w Paryżu.

Zakotwienie belki.

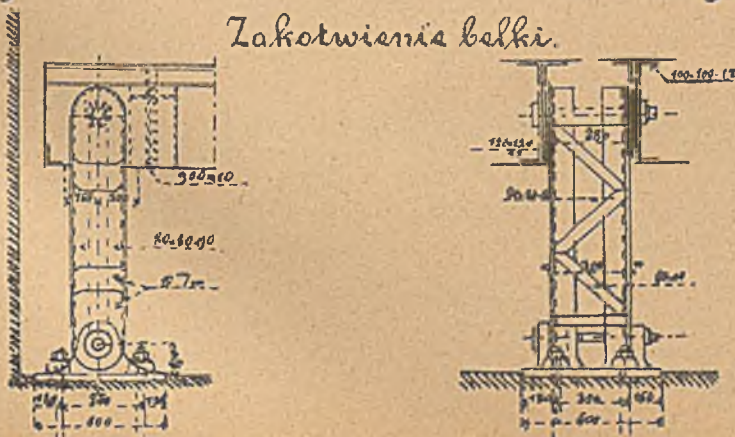

Rys. 7.

Skullie. Mosty kratowe zel.

Rys. 1. Nowy most na Wisle pod Torowem.

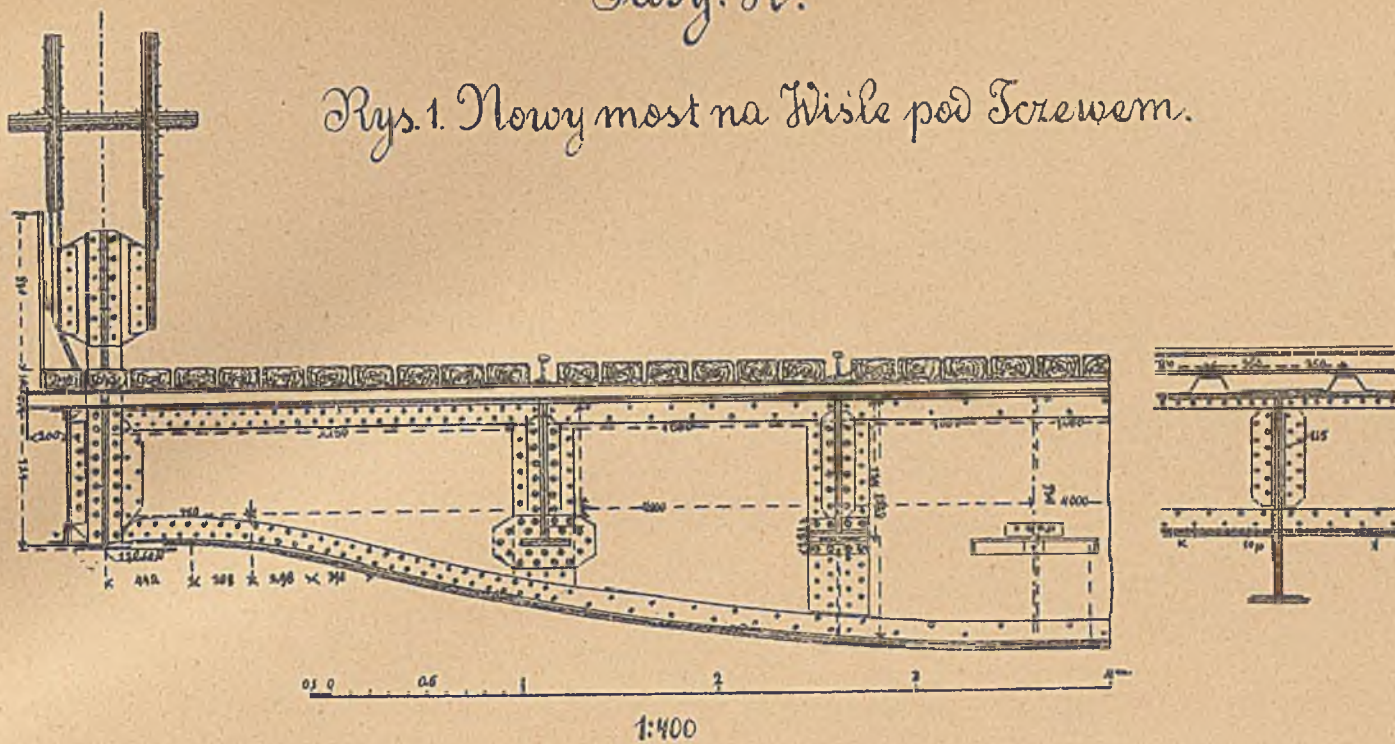

Rys. 2a. Most na Saali w Bernburgu.

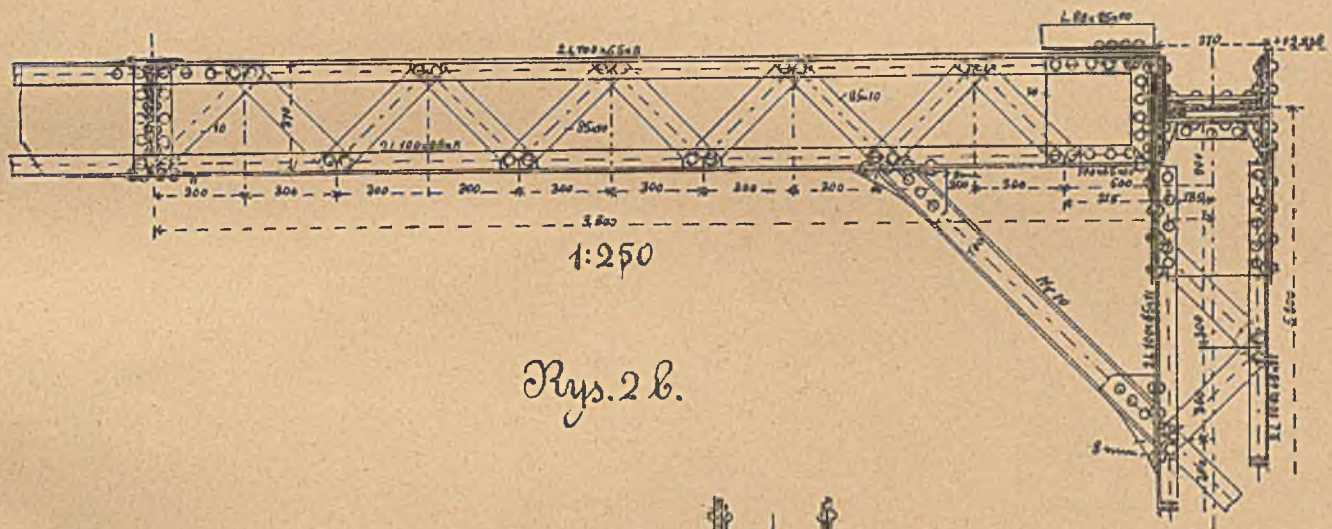

Rys. 2 b.

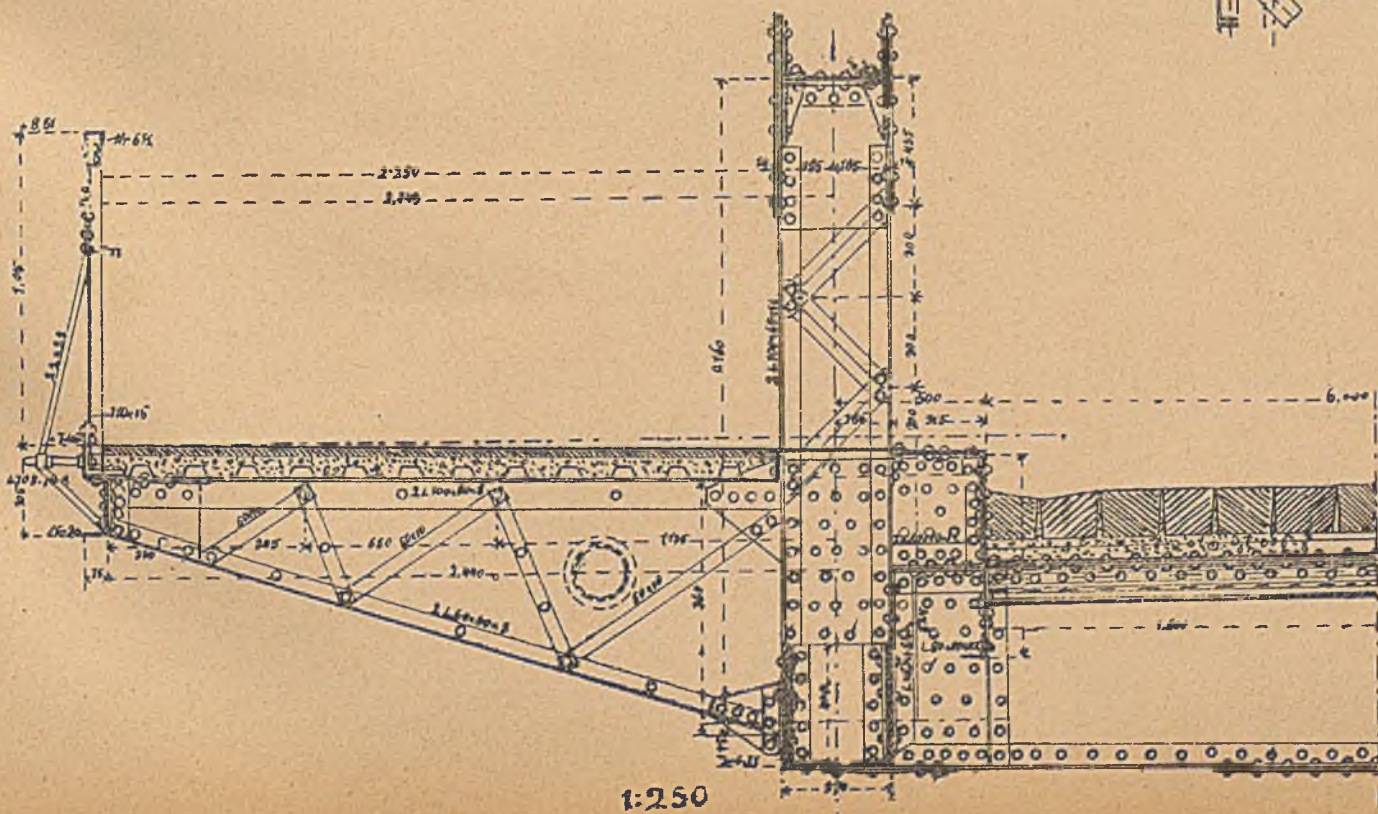

Rys. J. D.

Krzyżulce.

Ustroj angielski.

Rys. 1.

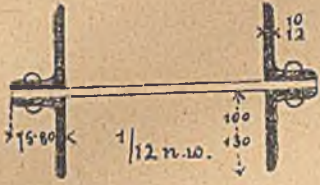

Rys. 2. Most na Allegbanj.

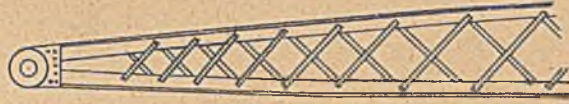

Rys. 3.

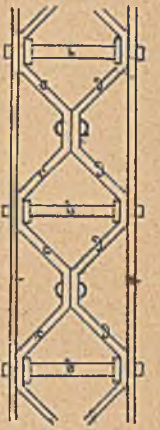

Rys. 4. Zastrzał Schiffkorna.

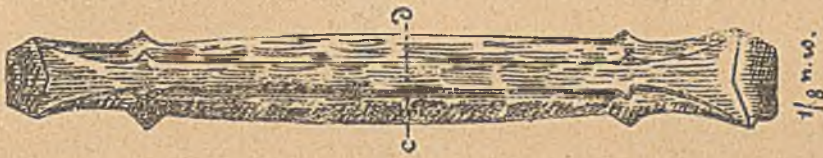

Rys. 5.



Rys. 6.

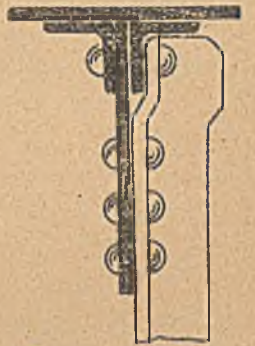

Krzyżowanie się krzyżulców.



Rys. 9.

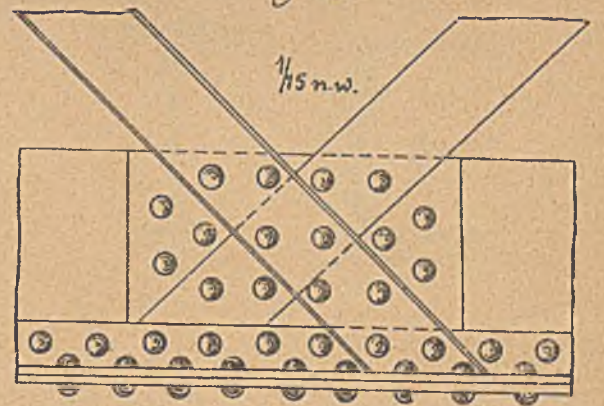

Rys. 7. Podkładki



Rys. 8.

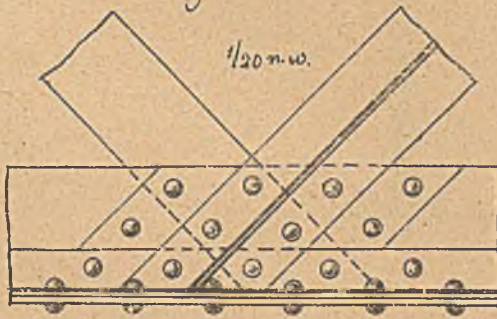

Rys. 10. Most na Mborzeli pod Koblencyą

1/15 n.w.

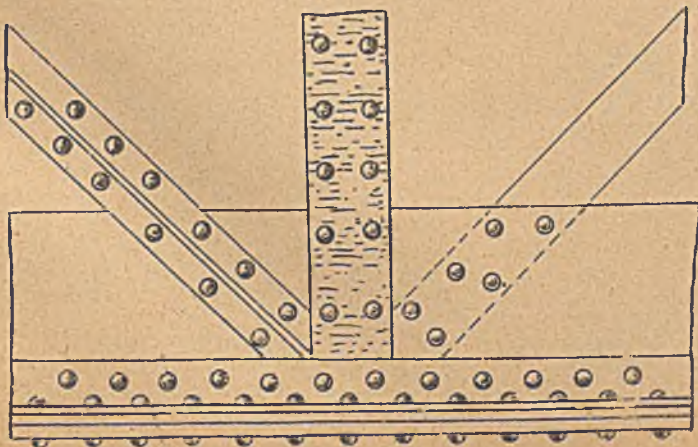

Rys. 11. Most na Wiedence w Wiedniu

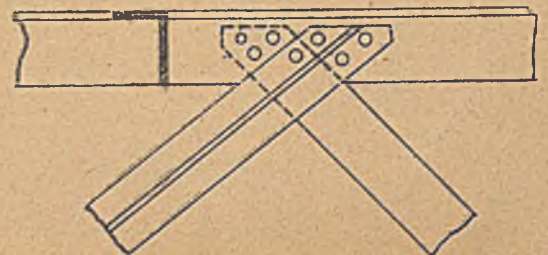

Rys. f. d.

Konstrukcje cislone.

Rys. 1.

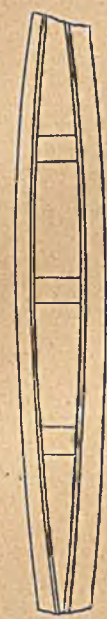

Rys. 2.



Rys. 4 a.



Rys. 4 b.

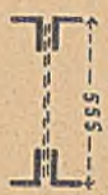

Rys. 3. Most nad Saara,



Rys. 5.



Rys. 6. Most na Iniew Sa
1/10 n.w.

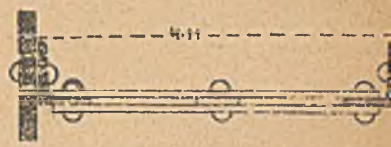

Rys. 8. Most na Sprewie
w Berlinie.

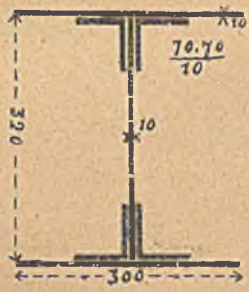

Rys. 9. Most na Garonne
pod Bordeaux.



Rys. 11. Most na
Ebrze.



Rys. 7. Most na delinie

Mielke.



Rys. 10. Most na Seracie
pod Basikanami w Rumunii



Rys. 12.



Rys. 14. Most na Renie pod Mannheim
1/15 n.w.

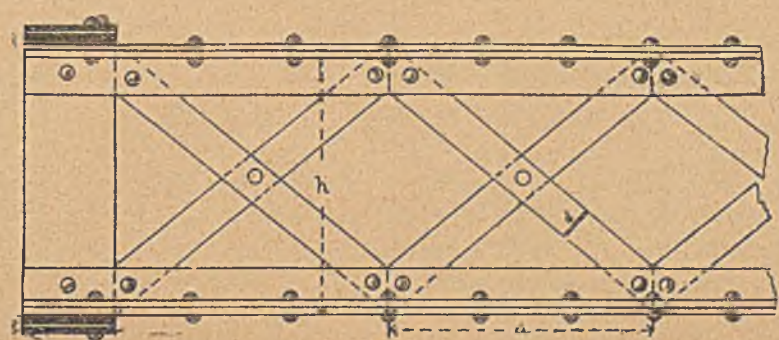

Rys. 15.



Rys. 13. Most na Sabnie w
Sabnstein..

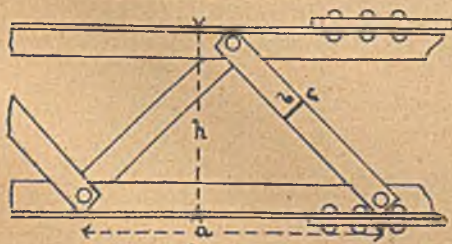

Skullie. Mosty kratowe zelarne.

Rys. 13.

Przekroje krzyżulców i pasów.

Mosty włoskie. (KRZYŻULCE)

Rys. 1a.

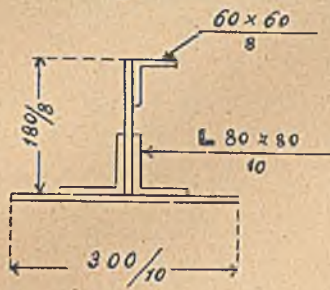

Rys. 1b.

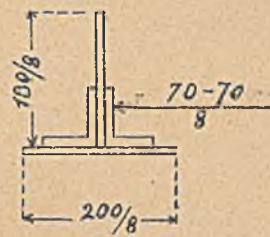

Rys. 2. Wiadukt na Bławois pod Gerbausem. (KRZYŻULCE)



Most na Forth pod Queensferry.

Rys. 3a. Pas górny.

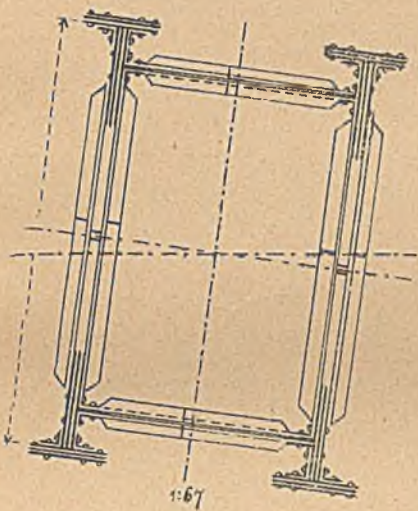

Rys. 3b. Pas dolny.

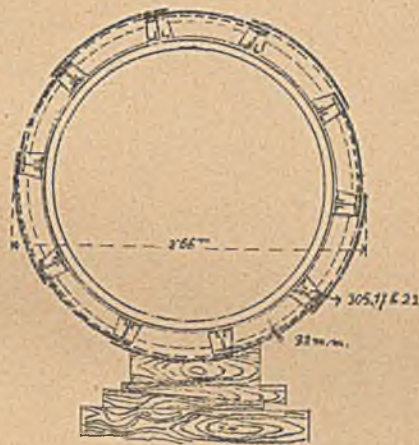

Rys. 4. Mosty włoskie. (PAS)

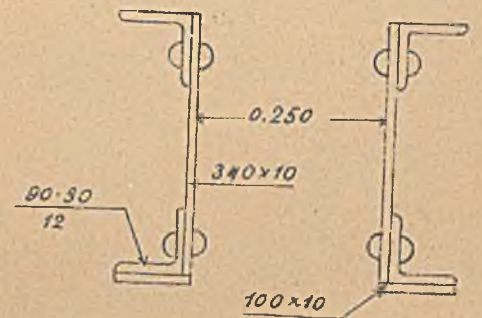

Most kolei Izmid-Angora

Rys. 5a.

l. 20

Rys. 5b.

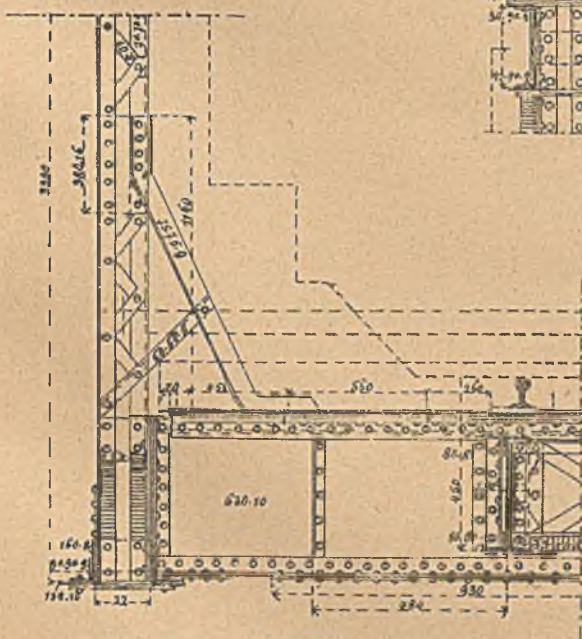
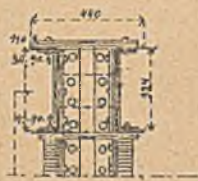

1:30

Rys. 5c.

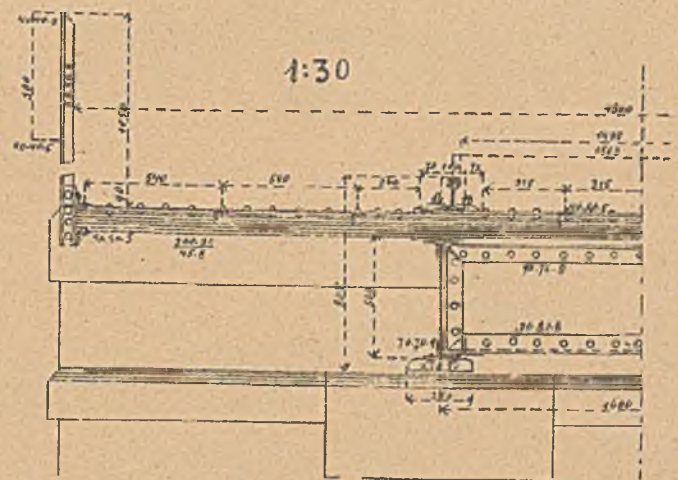

Rys. 6. Most Fatberbew S^t. Louis (Senegal)

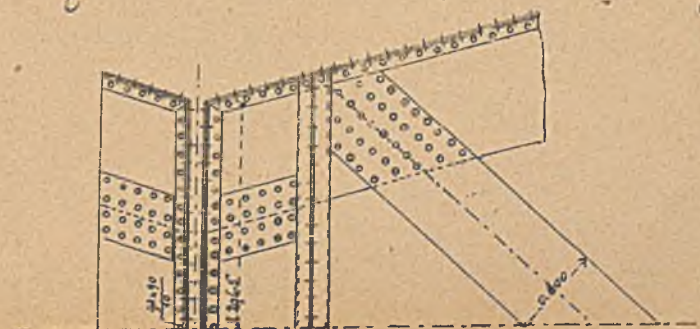

Rys. 6.

Rys. 1. Most na Gbrze 1/20 n.w.

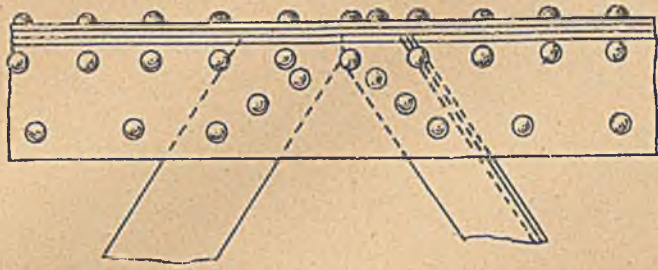

Rys. 2. Most na Łabie pod Uściem. 1/10 n.w.

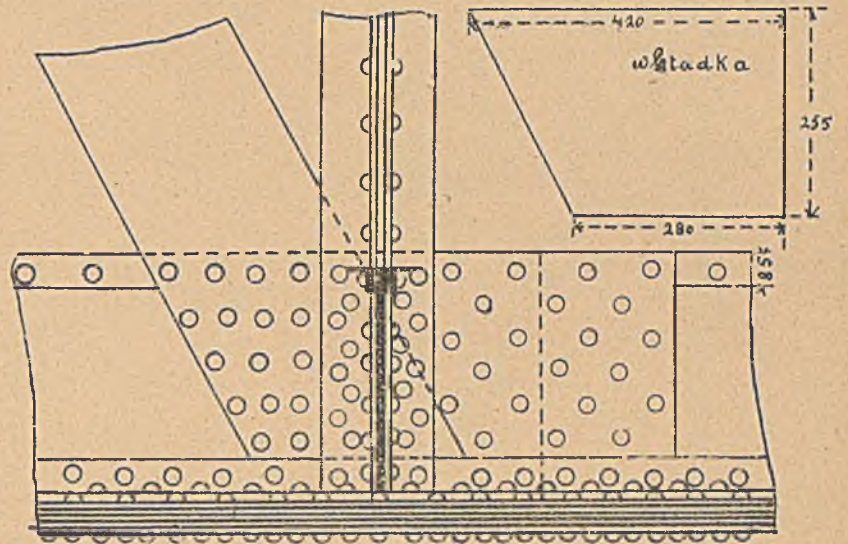

Rys. 3.

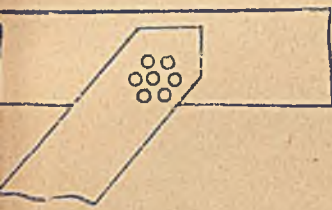

Rys. 4.

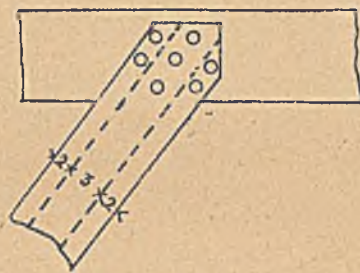

Rys. 5. Most na Kanale Dunaju w Wiedniu.

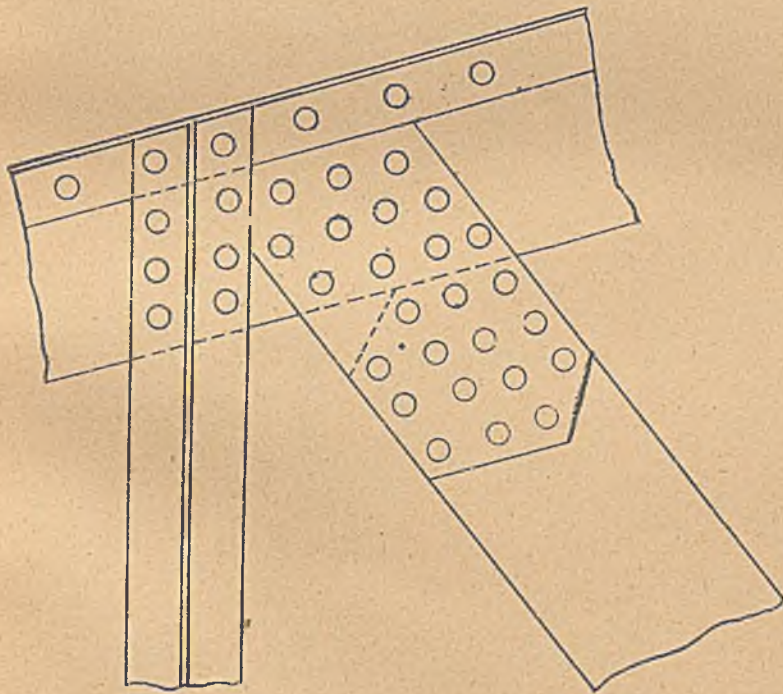

Rys. 6. Most na Warcie w Poznaniu. 1/20 n.w.

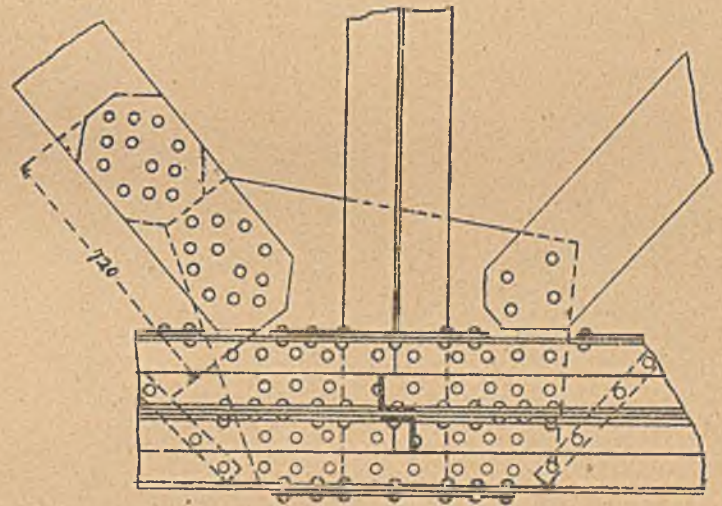

Rys. 7. Most na Rennie pod Grietbansen. 1/12 n.w.

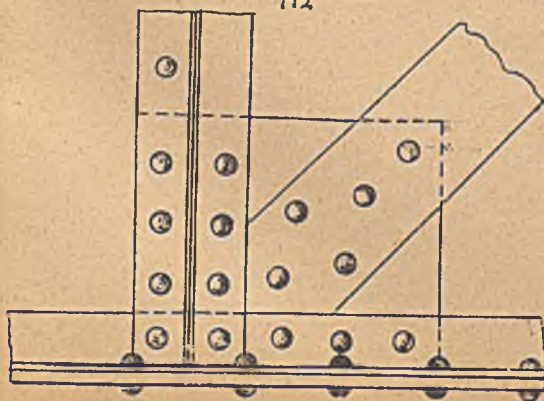

Rys. 8. Most na Innie pod Imstem.

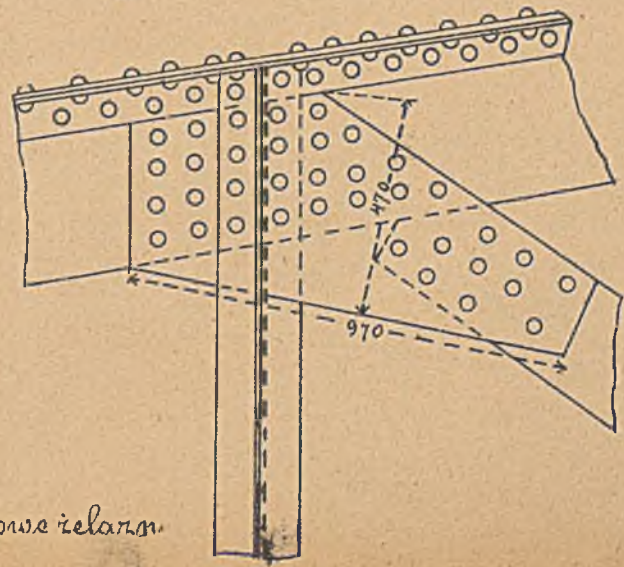

Skullie. Mosty kratowe zelazn.

Rys. 4. 5

Rys. 1. Most na Dunaju w Strygonii

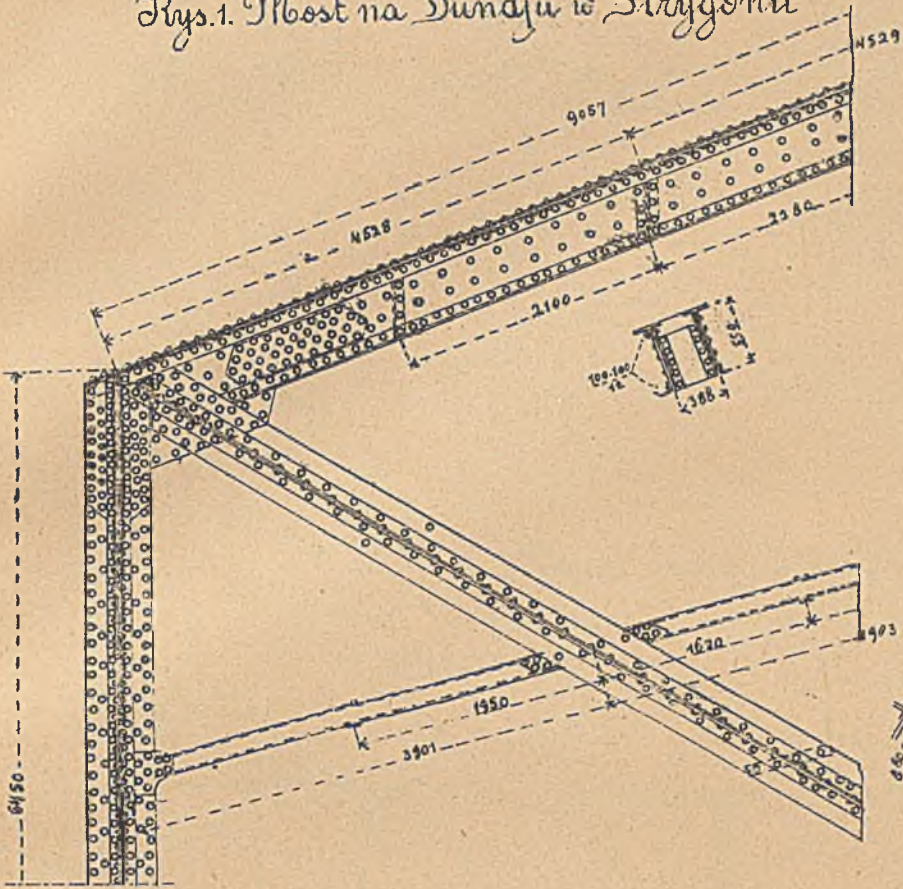

Rys. 2. Most na Belai kol. Samara-Ufa

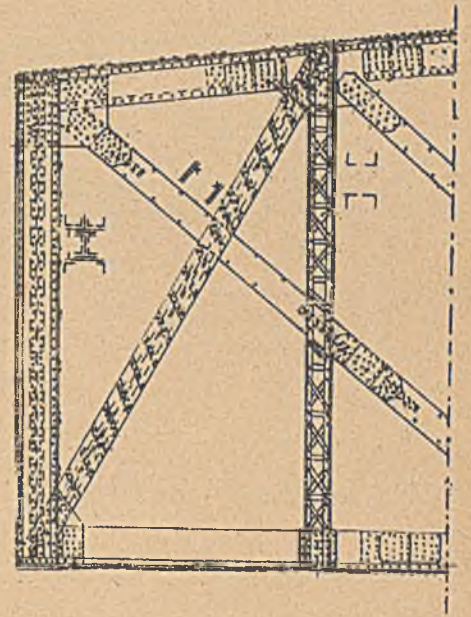

Rys. 3. Most na kanale des Rapides.

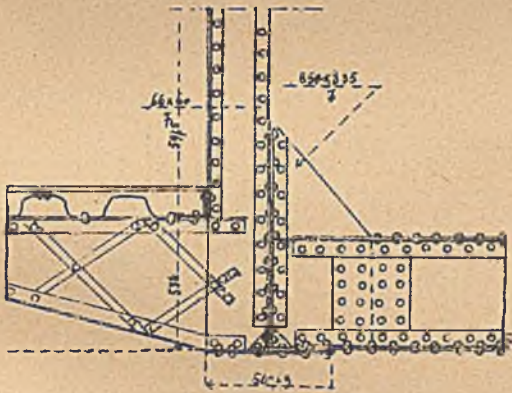

Rys. 4. Most na Labie w Jaroměř

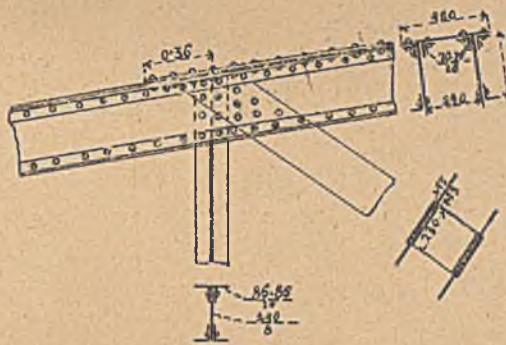

Rys. 5. Mosty.

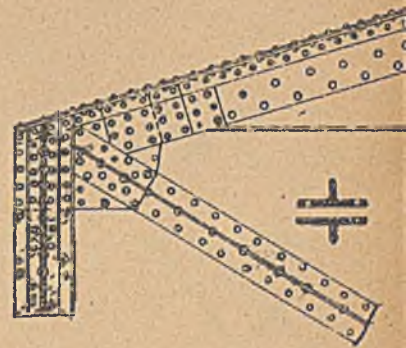

Rys. 6. Most kolei Rudolfa

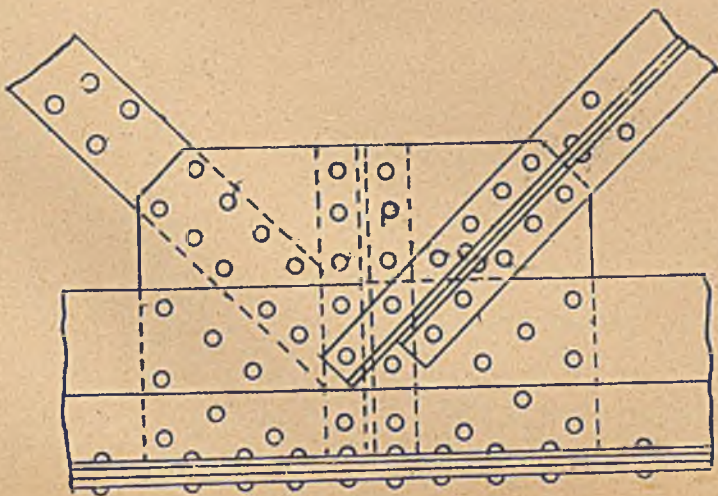

Rys. 7.

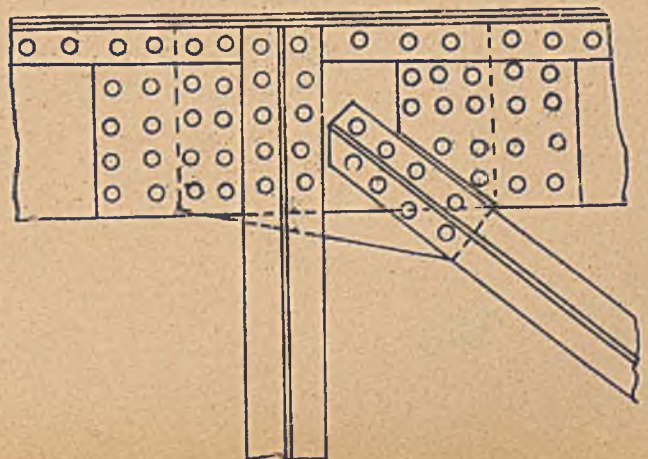

Rys. 1.

Strzał proj. mostu na kanale la Manche.

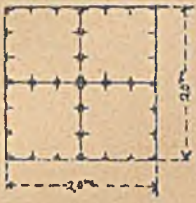

Rys. 2.

Zastrot mostu na Emmie w Dolkusen.

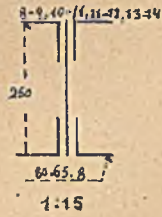

Rys. 3. Połączenie poziome korpor. gornych mostu na Innie pod Telfs.

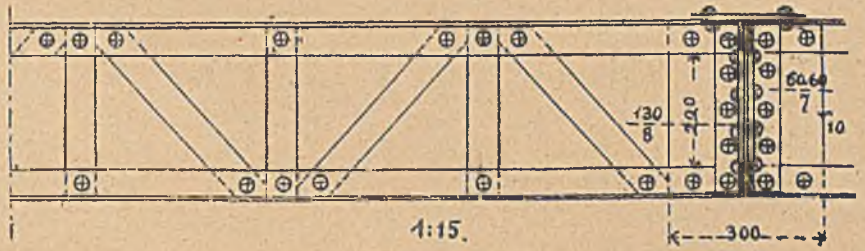

Rys. 4. Most na Skawie w Dadowicach.

Przekrój pasu

Przekrój narożnika

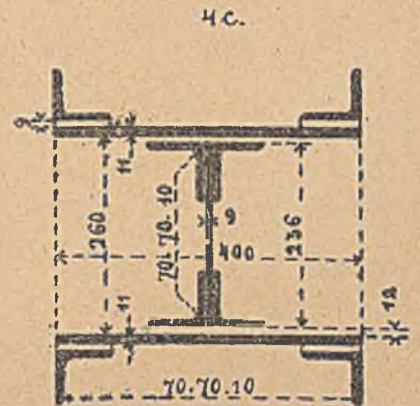
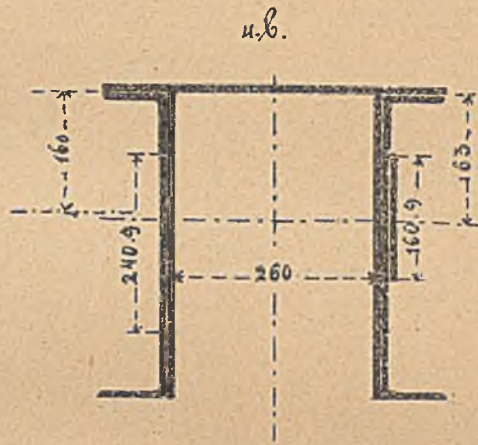
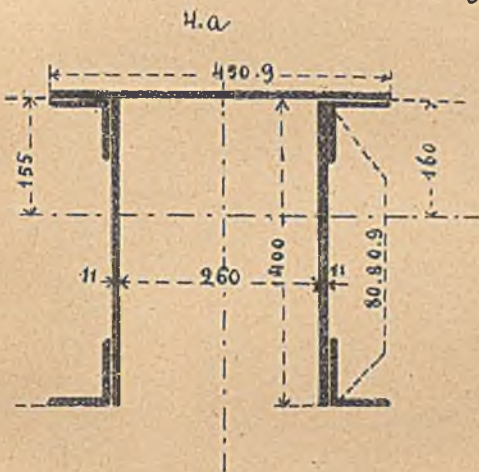

4.d. Widok słupa.

Rys. 5. Ornazenie nitów.

Rys. 6.

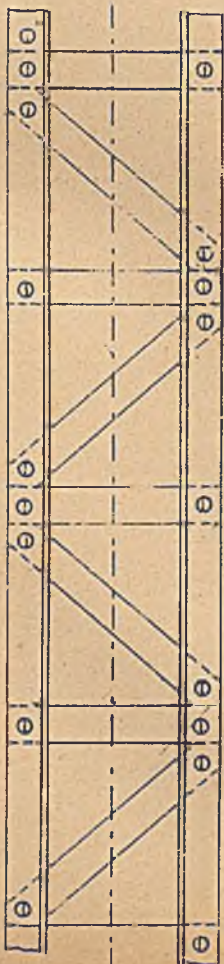

Nit grubości	○	◐	20 m.m.
" "	⊗	◑	18 m.m.
" "	◉	◒	22 m.m.
" "	⊗	◓	24 m.m.
" "	◎	◔	26 m.m.



- głowa zewnątrz wypuszczonea ⊗
- " wewnątrz " ⊗
- obie głowy wypuszczone ⊗
- głowa wewnątrz spłaszczonea ○

Rys. 7

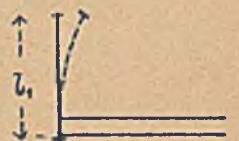

Rys. 8.

Rys. 9.

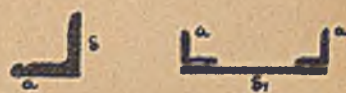

Rys. 10.

Kształt belek.

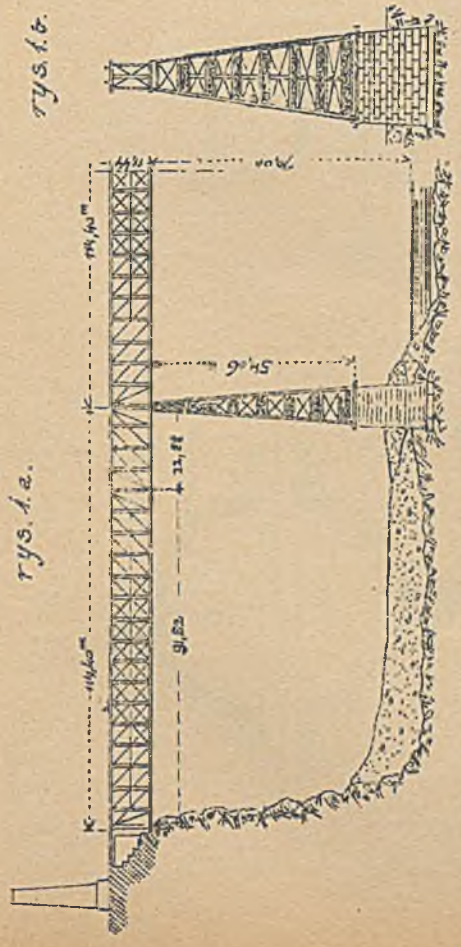

Wiadukt n. Kentucky kol. Cincinnati Southern.

rys. 2.2

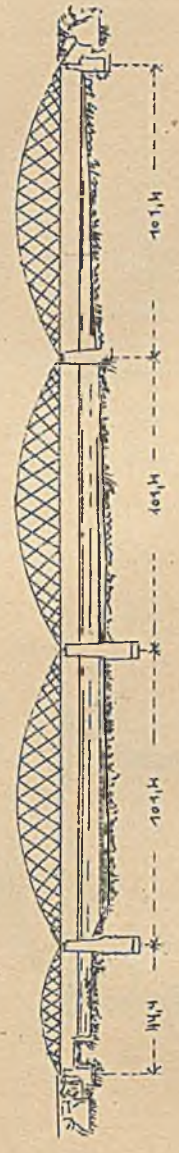

M. na Łabie pod Ricsą.

rys. 2.b.

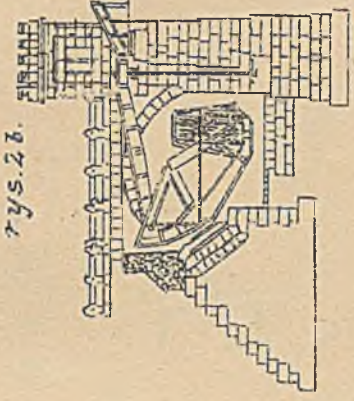

rys. 2.c.

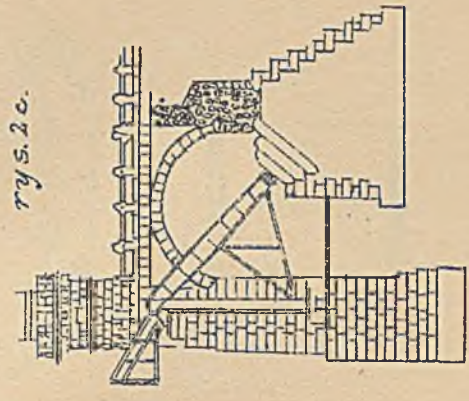

rys. 3.

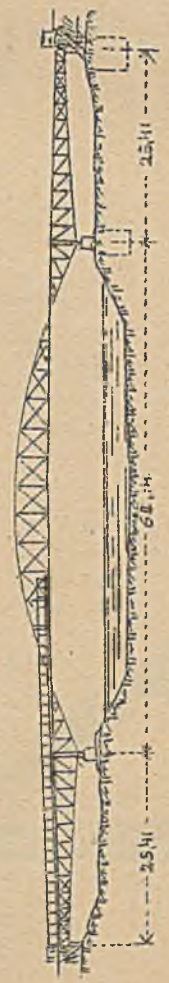

M. na Amizie pod Tunxdorf.

rys. 4.

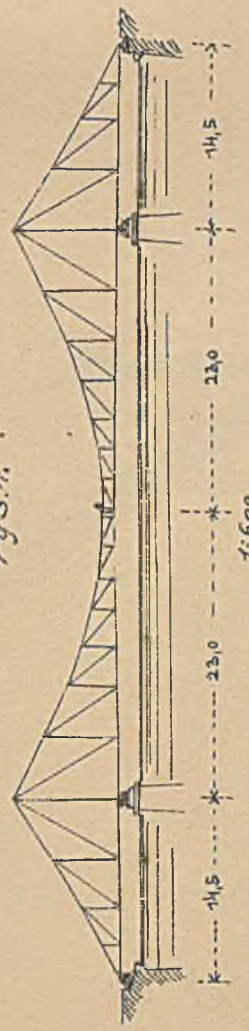

M. na Wezerze w Hameln.

rys. 5.



M. na Licking koto Cincinnati.

Dr. M. Thullie: Mosty kratowe zelazne.

rys. 1

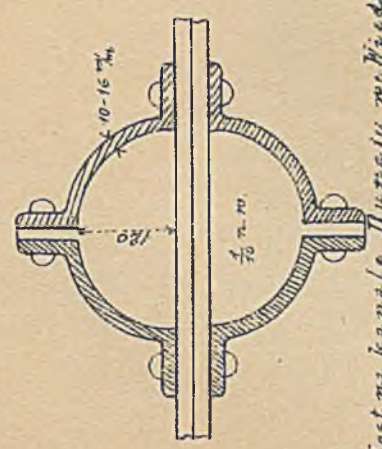

Most na kanale Dunaju w Wiedniu.

rys. 2.



M. na Obrzy w Łatcu.

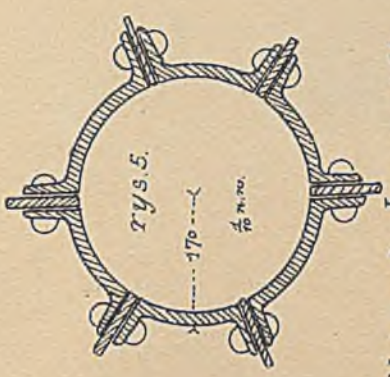

M. na Ohio pod Louisville.

rys. 3.

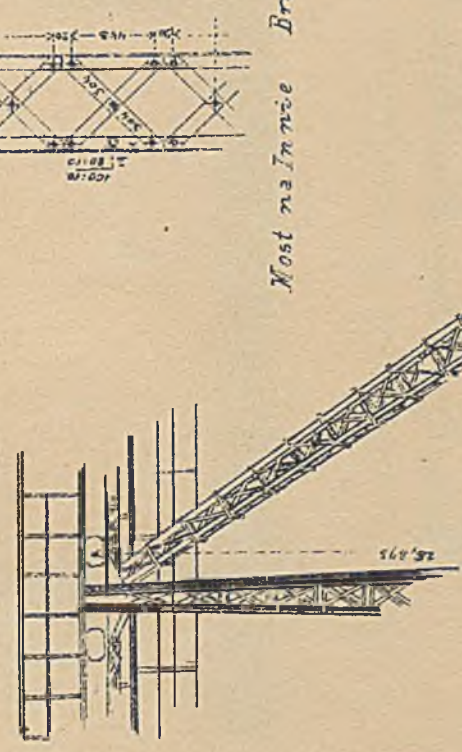

Most na Innie Braunau-Sambach.

rys. 6.

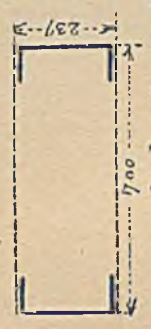

M. na Dunaju kolpóm. w Wiedniu.

rys. 4.

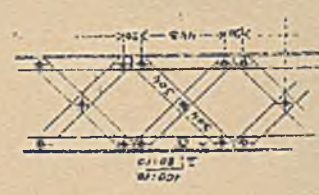

M. na Dunaju w Mauteriu.

rys. 8.

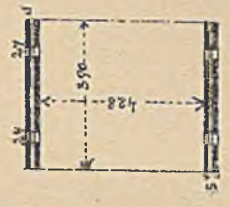

M. na Dunaju w Mauteriu.

rys. 10.

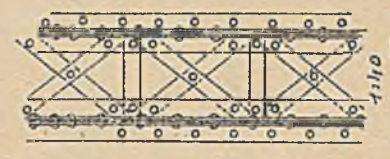

M. na Dunaju w Mauteriu.

rys. 11.



Dr. M. Thullie: Mosty kratowe zel.

M. na Innie p. Passarua.

Kształt belek

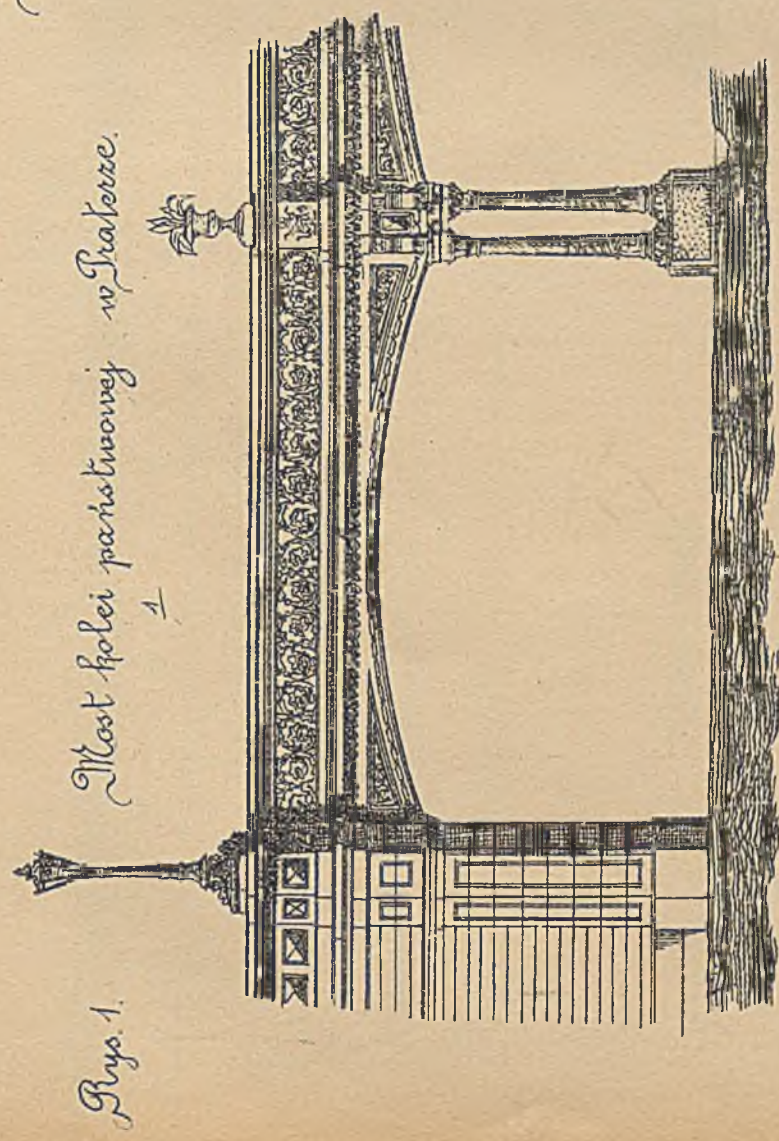

Rys. 1. Most kolei parostawowej w Praterze.

Rys. 2

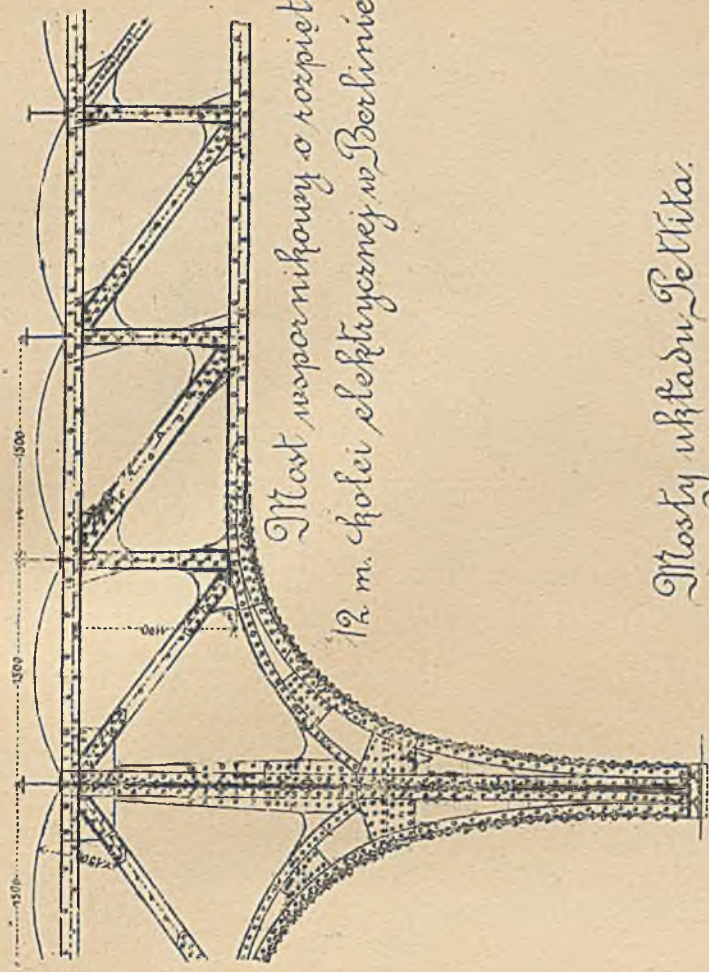

Most wspornikowy o rozpiętości 12 m. kolei elektrycznej w Berlinie.

Mosty wkładu Tetita.

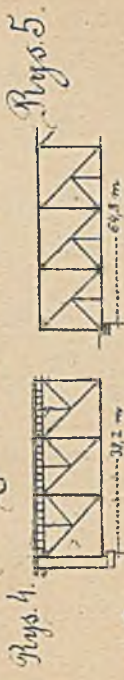

Rys. 4.

Rys. 5.

Rys. 6 Most nad portem Humboldta w Berlinie.

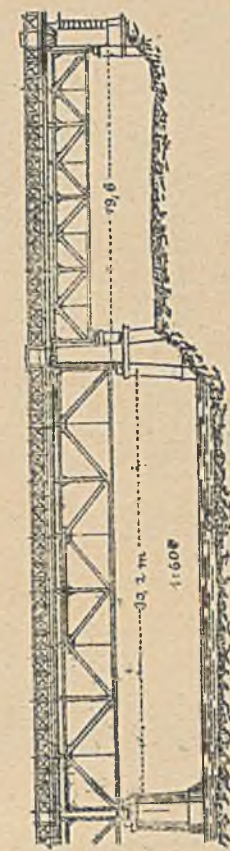

Rys. 7. Most kolei Szwajcarskiej.



Most kolei Szwajcarskiej. Rys. 8.

Rys. 1.

Most na Ohio kolei Cincinnati Southern.

Rys. 3 Most na Ohio pod Louisville. 130 m. w.

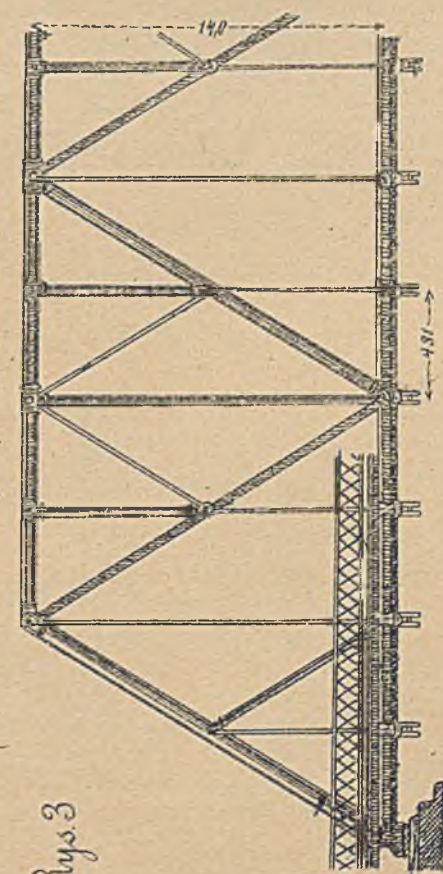

Rys. 3

Rys. 9. Most na Dunaju pod Gross-Siebersdorf. 1800 m. w.



rys. 1.

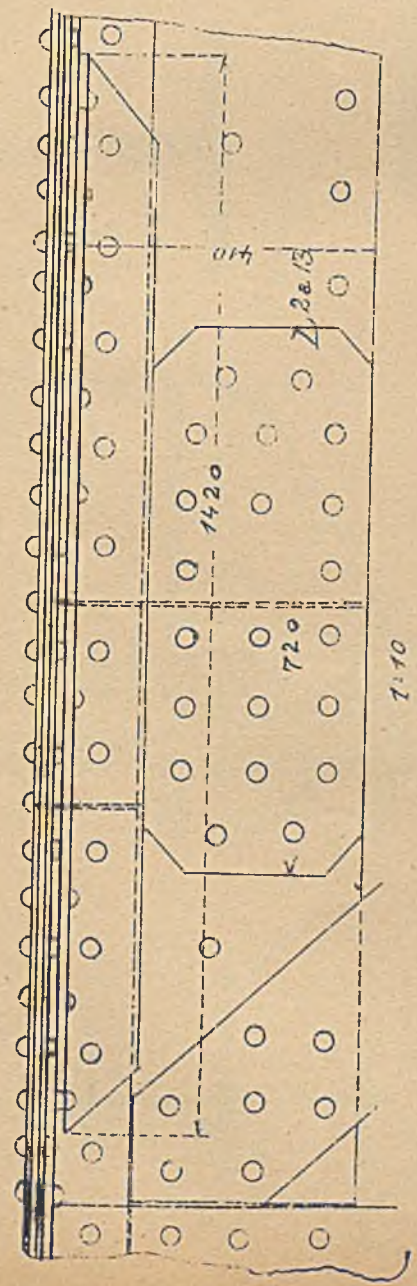

М. на Лягу р. Калесханами.

1:10

rys. 2.



М. на Ирие р. Пассава.

rys. 3.



rys. 4.



rys. 5.



rys. 6.

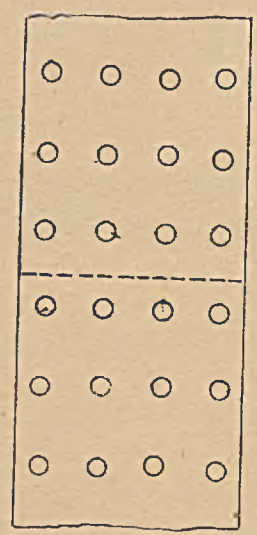

rys. 7.

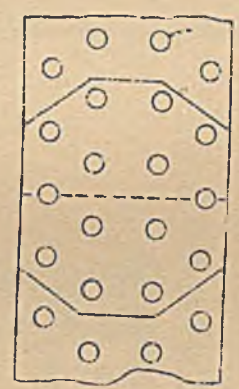

1/2 n.v.

rys. 8.

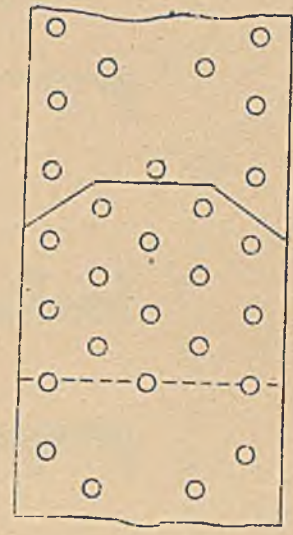

1/5 n.v.

rys. 9.

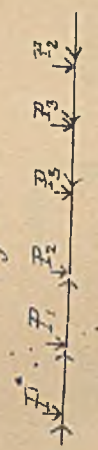

D. M. Thullie: Mosty kratome zel.

rys. 1.

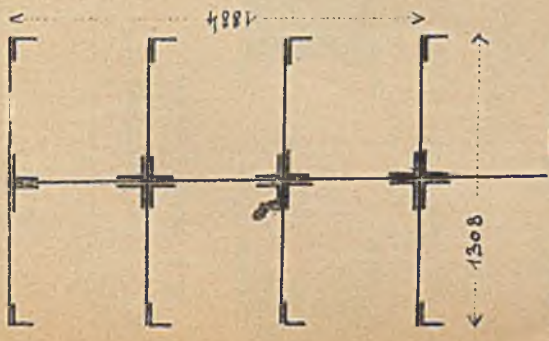

M. na Wiśle pod Troszowem

rys. 2.

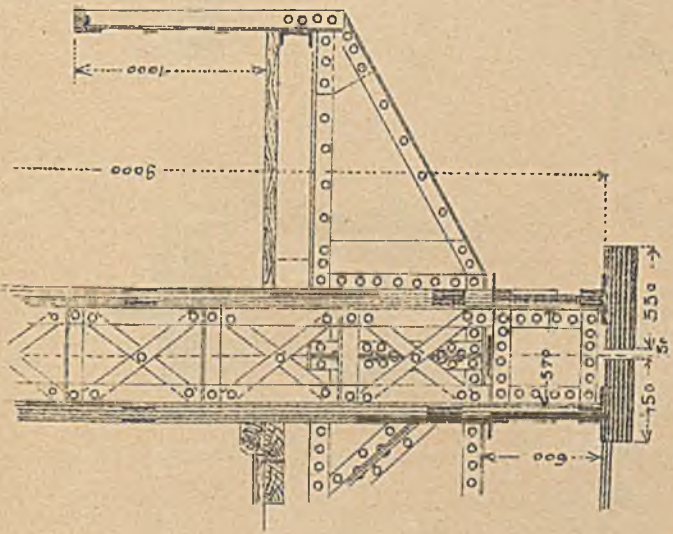

M. kol. Inwangröd-Dąbrowa.

rys. 3.



Wiadukt p. Czerwoną na Wollawie.

rys. 6.



M. pod Czernawodą na Durawju.

rys. 4a.

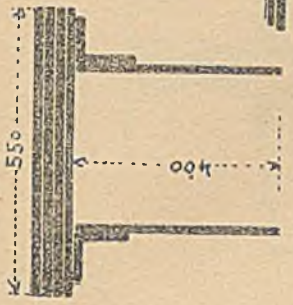

rys. 4b.



M. na Dun. p. Maria-Orl w Bawaryi.

rys. 7.

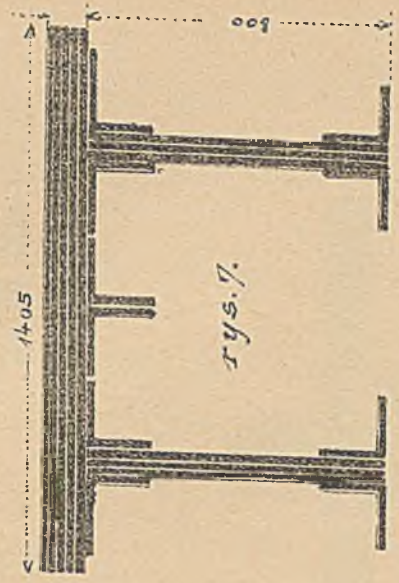

M. Fran. Józefa w Peczcie.

rys. 11.



rys. 12.

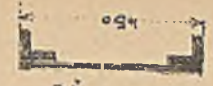

M. n. Belaja kol. Samara-Ufa.

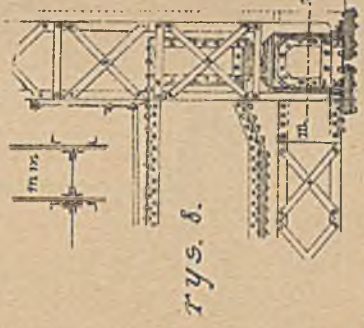

rys. 10.

M. na Dun. w Sigmaringen. M. n. Reuchw. Ban.

Mast na Renie w Kolonii.

rys. 14.



rys. 13.



rys. 5.



Pas ameryk.

rys. 9.

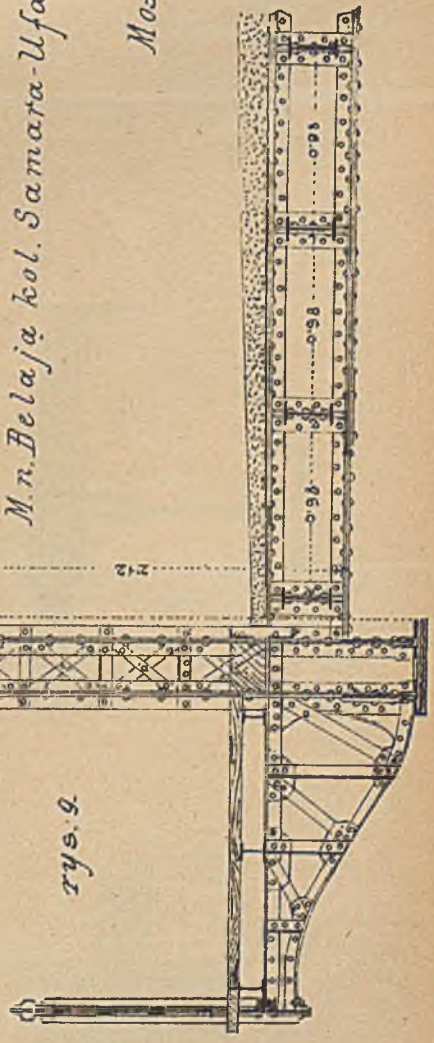

rys. 12.



Pas łączący.

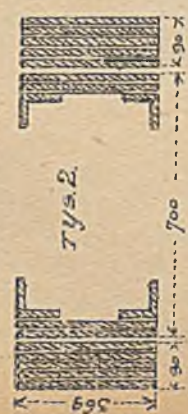

Most na Dunaju.

rys. 1. b.

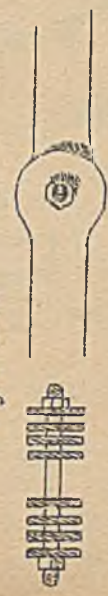

M. na Trenčie pod Neu mark.

rys. 6.

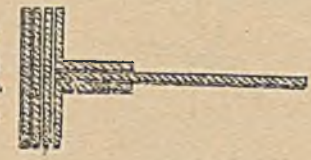

col. contr. w Szewcarych

rys. 5.



rys. 3.



M. na Renie w Mogunycy.



M. na Lahnie.

rys. 7.

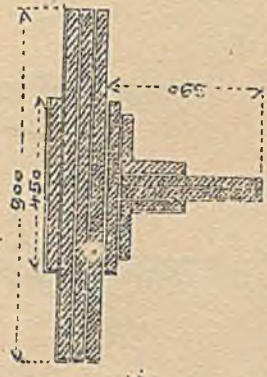

M. n. Renie p. Wéldhut.

rys. 8.

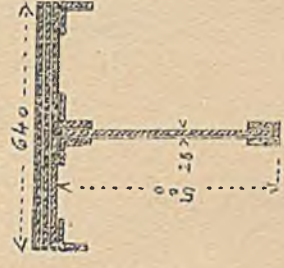

M. na Dunaju.

rys. 16.

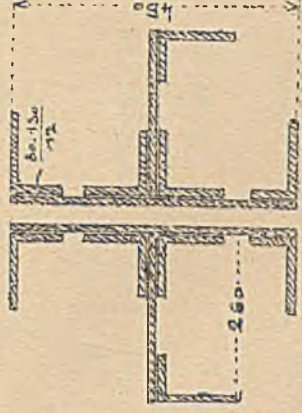

M. na Dunaju p. Jgolstadt.

rys. 14.

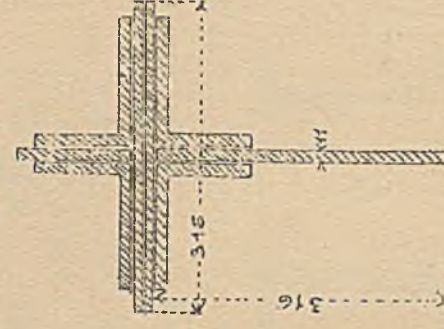

M. n. Renie w Mogunycy. M. p. Dupel n. Węgrzech.

rys. 12.

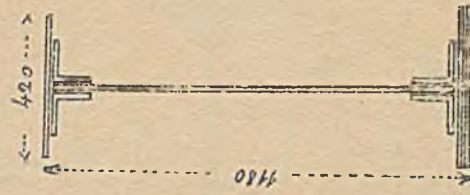

rys. 9.

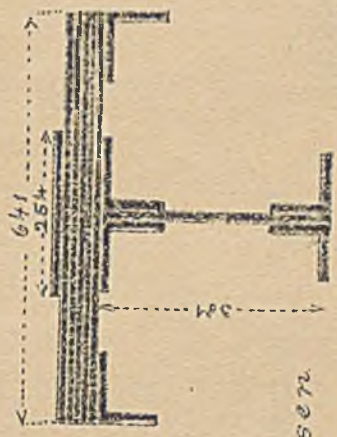

M. na Renie p. Griethausen.

M. n. Wezrze w Bremie.

rys. 13.

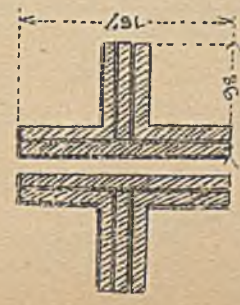

D. M. Thullie: Mosty kratowe.

rys. 15.

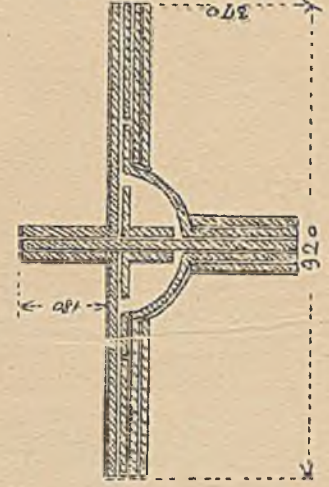

M. n. kan. Dun. p. Wiedniem.

rys. 11.

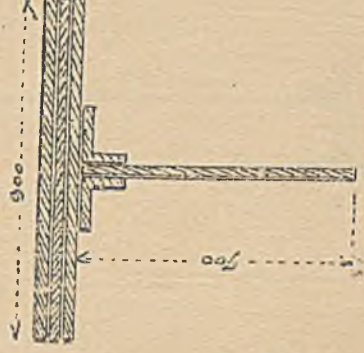

M. na Dun. k. Stadlau.

rys. 17.

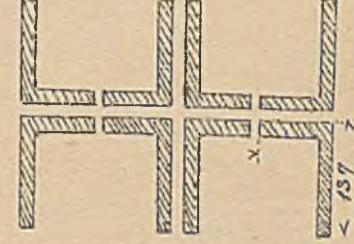

M. na Labie p. Misna.

Ustrój pasów

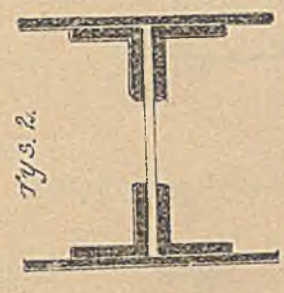
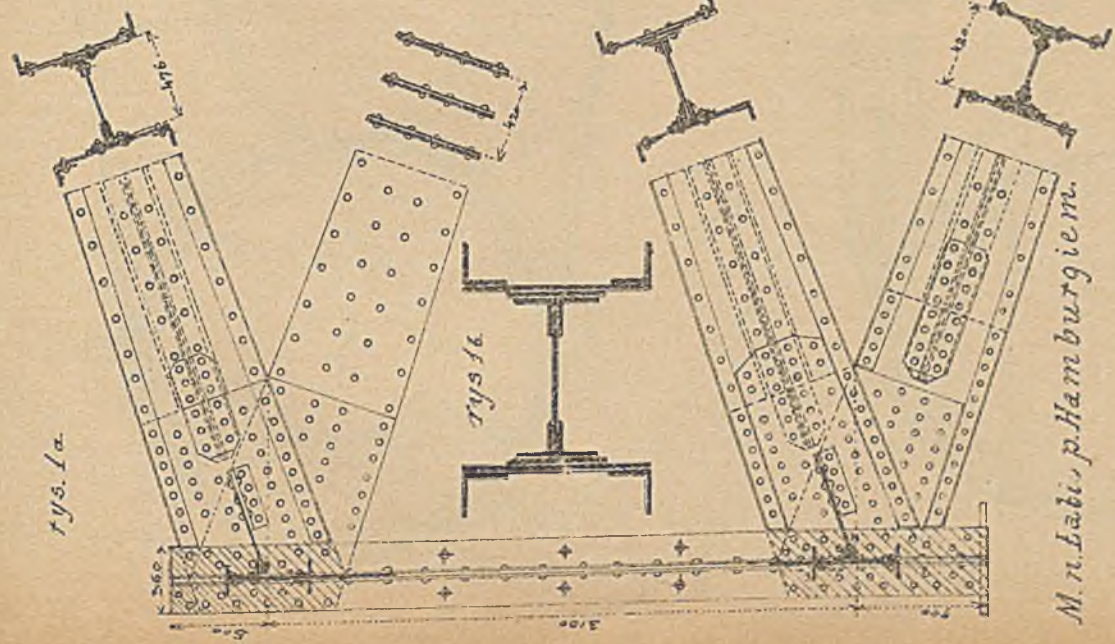

M. na Odrze we Wrocławiu

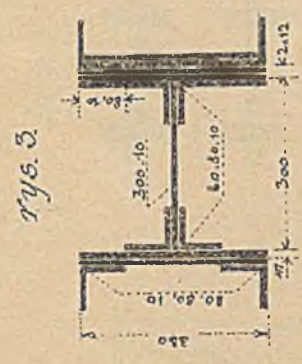

22 b.



M. kol. berl. (port Humboldt)



Pas tancuchowy



Wiad. n. dolina Mólke. (Śląsk)



M. k. miej. w Berlinie

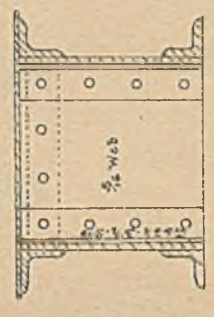

Most kol. transandyjskiej

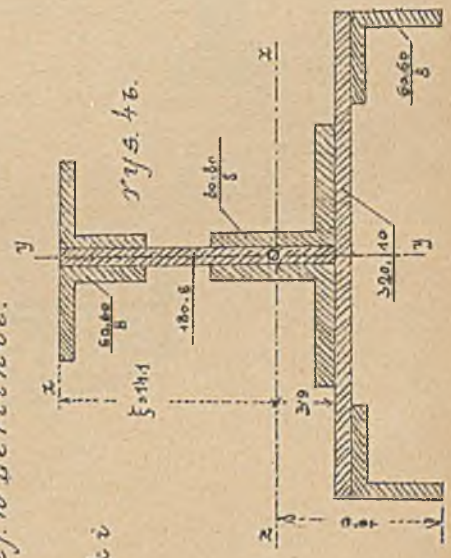

Most w Łoski

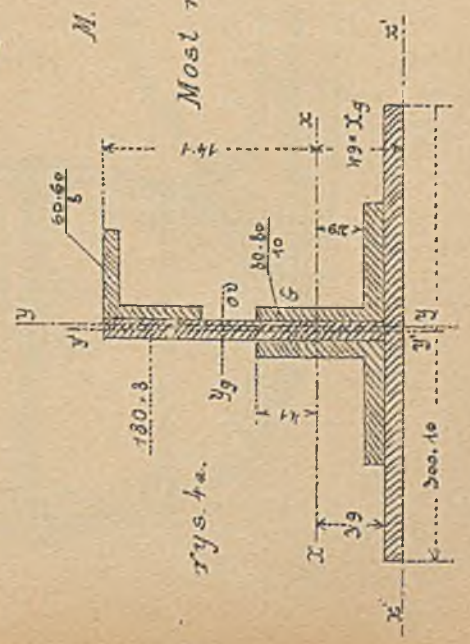

D. M. Thullie: Mosty kratowe.

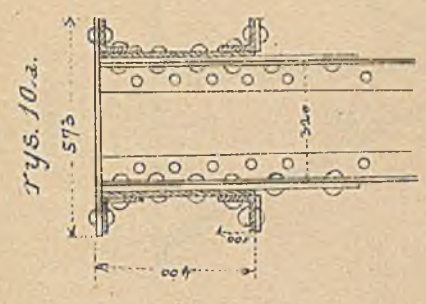

Most na Dun. p. Rechtenstein

rys. 10b

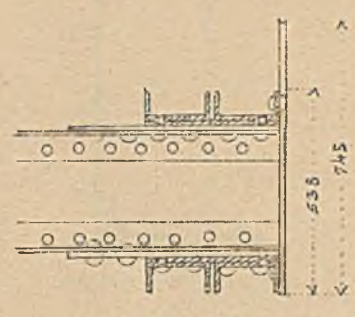

Pasy amerykańskie

Most Lepnia

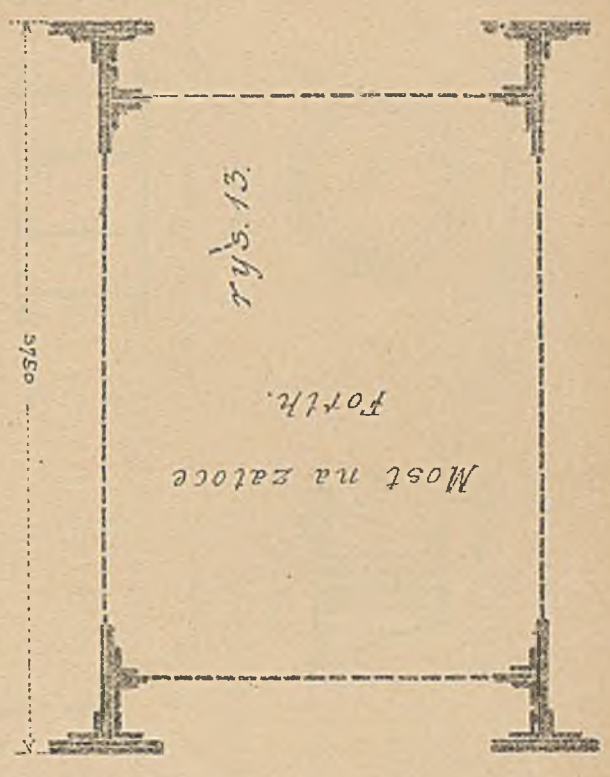

Most na zatoczce Fortk.

rys. 4



Ústroj pasón.

Tabl. 44.

rys. 1a.

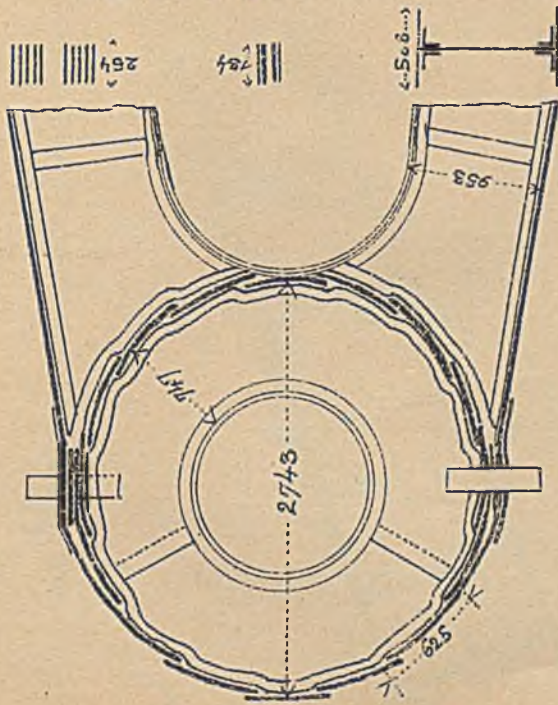

Most nad Wye pod Chepstow.

rys. 2a.

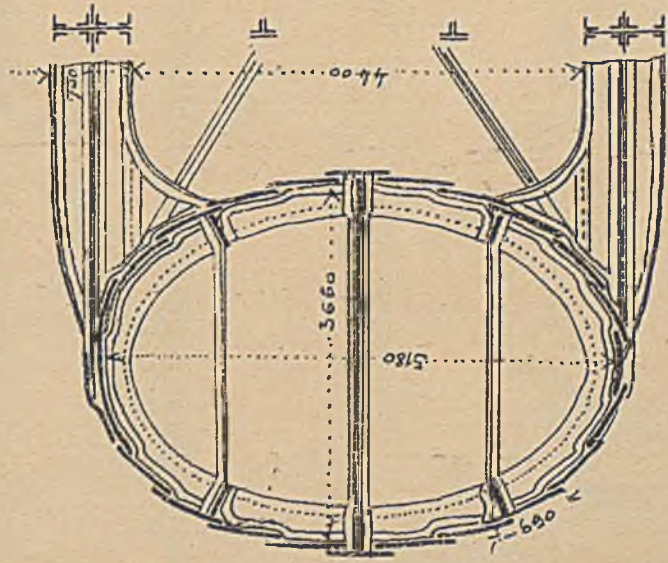

Most na Saltash.

D. M. Thullie: Mosty kratome.

rys. 1b.

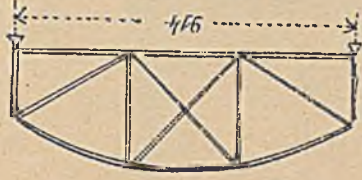

rys. 3.



M. n. Iabie w Szpandowie.

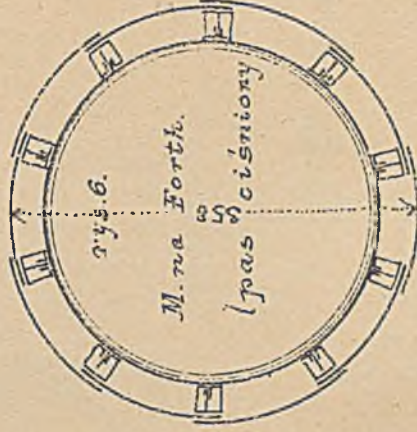

rys. 7.



rys. 2b.



rys. 5.



M. na kenale La Manche.

rys. 12.



Pas Schifkorna.

M. p. Newark.

rys. 4.

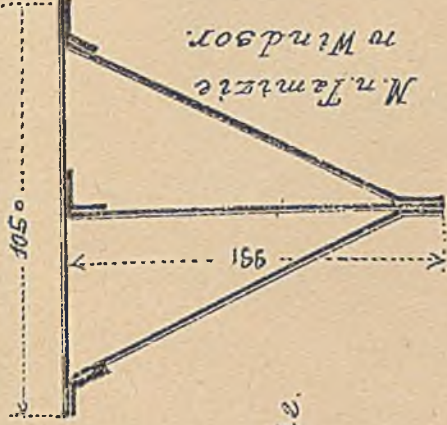

rys. 5.

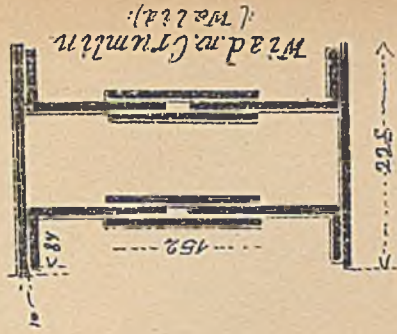

rys. 8.



P. Grosskesseloh.

rys. 10.



M. k. Pitsburg-Chicago.

rys. 13.



M. p. Newark.

rys. 11.



rys. 14.



M. n. Ohio p. Louisville.

Polaczenie mimośrodowe.

Most na Dnieprze pod Przeczyca.

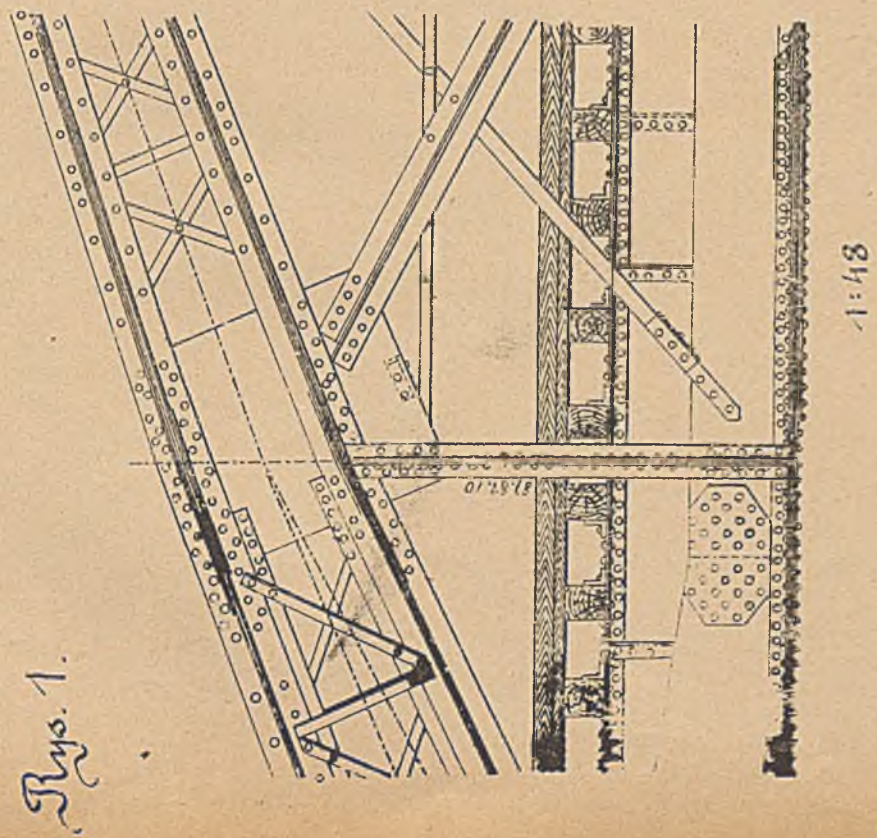

Most Stefana na kanale Dunaju w Wiedniu.

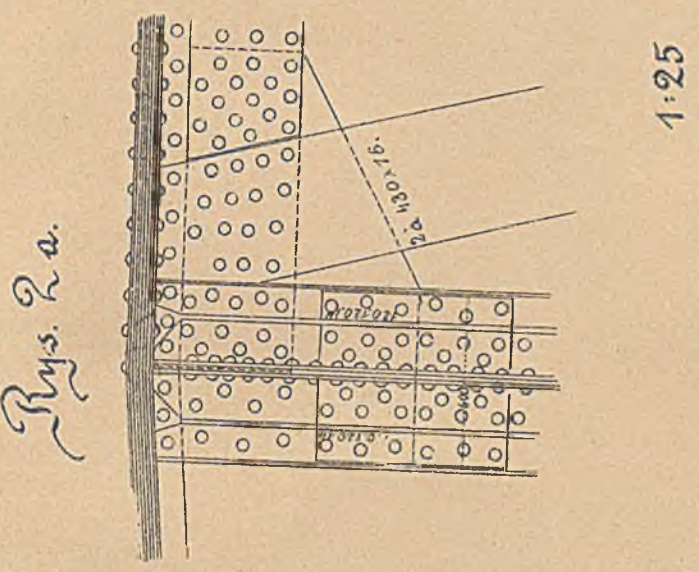

Rys. 2 b

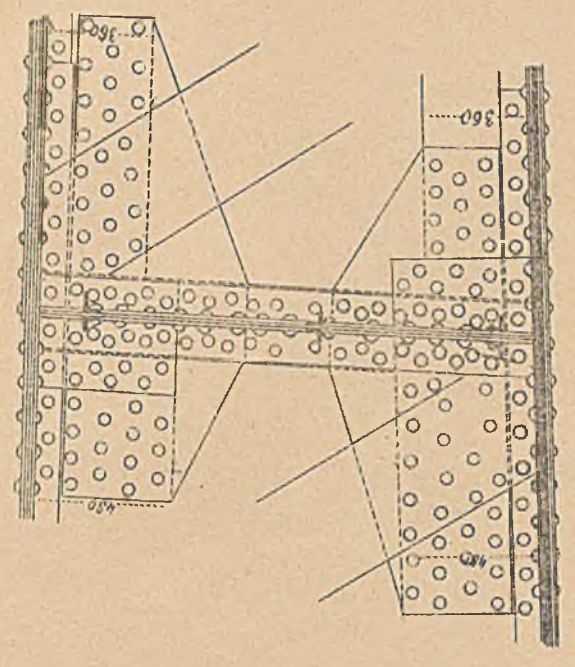

Most na Birs pod Mönchenstein.

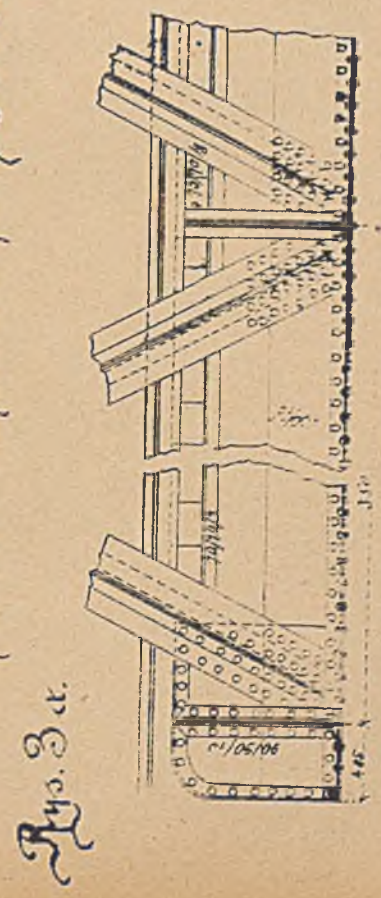

Most kolei Nowojarskiej.

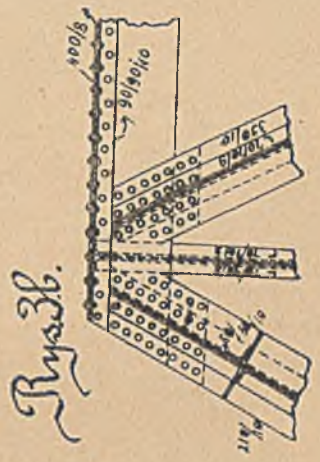

Rys. 4.

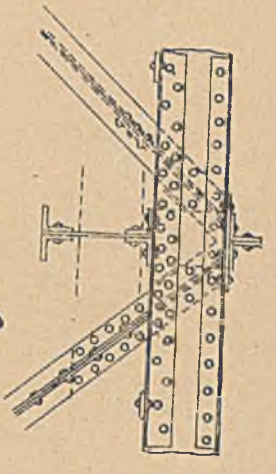

Mt. Thullie Mosty zeslane spalone.

Blachy wrotowe.
Most na Dunaju w Cernawodzie.

Rys. 1.

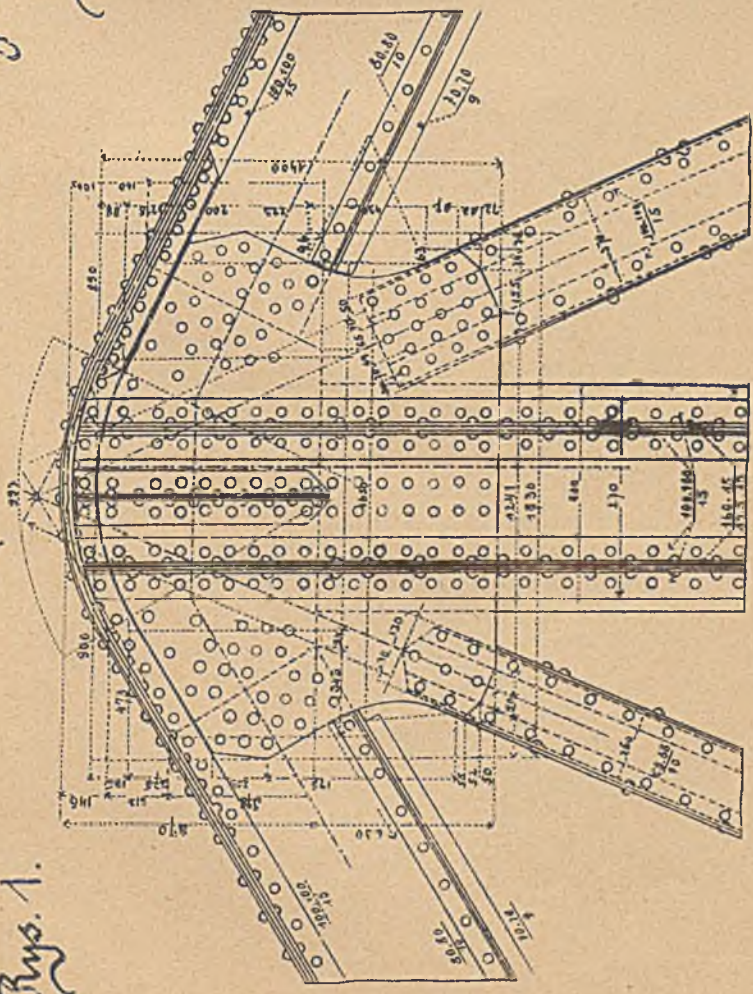

Rys. 2

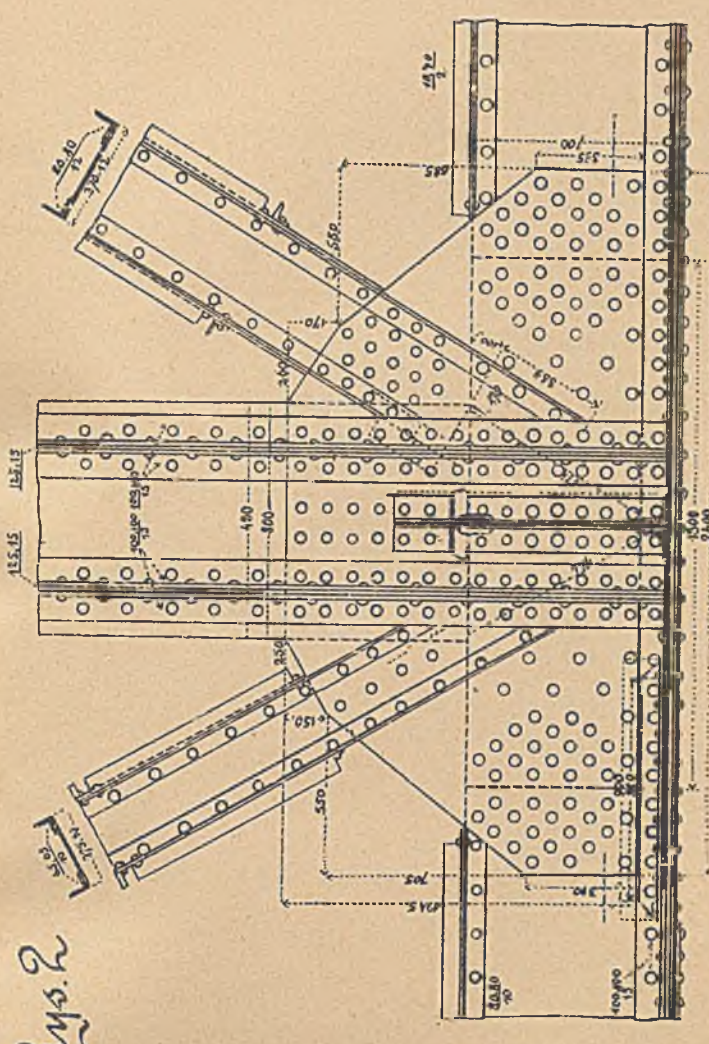

Most na Dunaju w Cernawodzie.

Rys. 3.

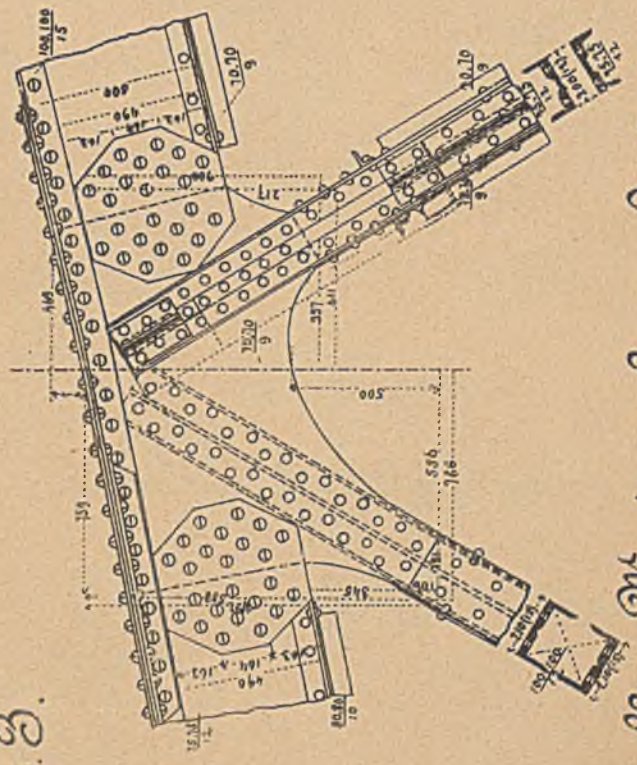

Rys. 4.

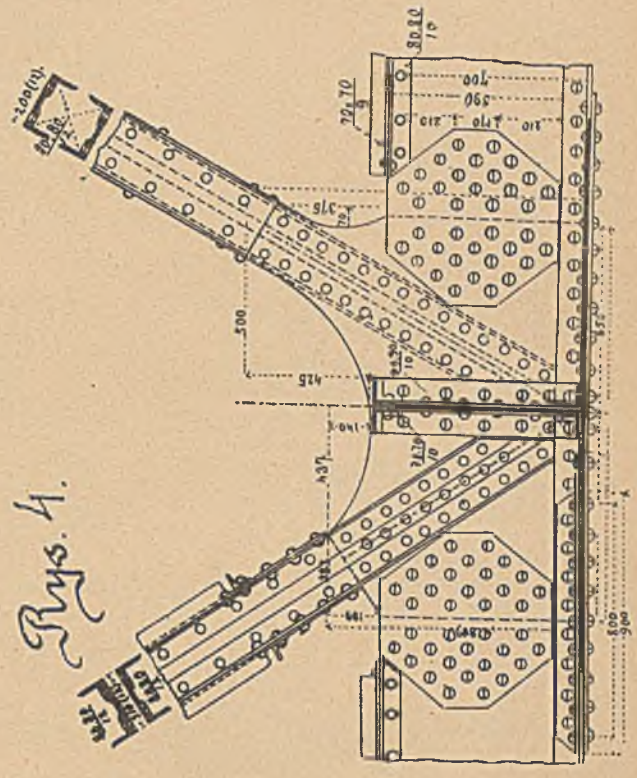

1:25

M. Thullie. Mosty relarne kratowe.

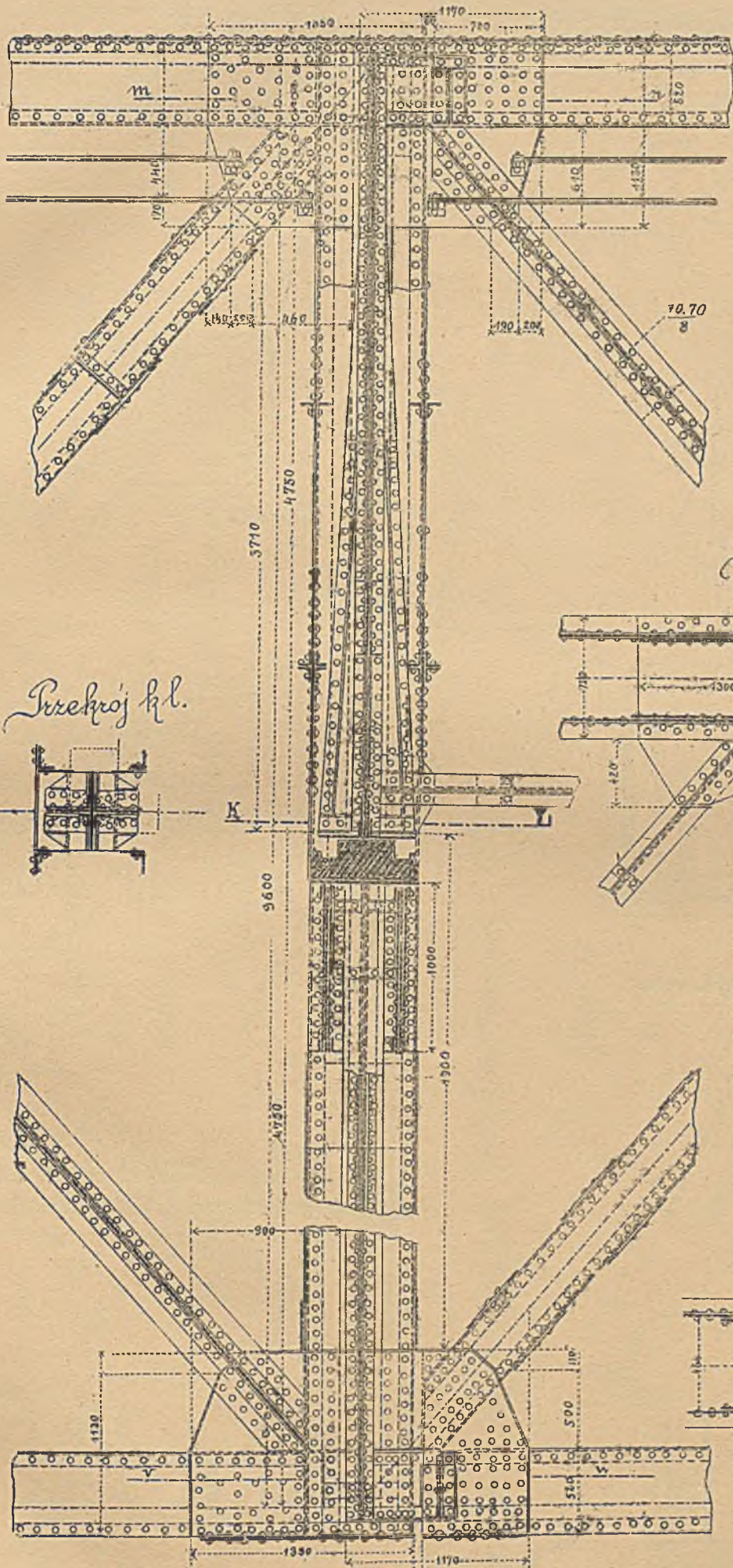

Viadukt
na Veltavie pod
Cervenu.

1:36

Przekrój v.w.

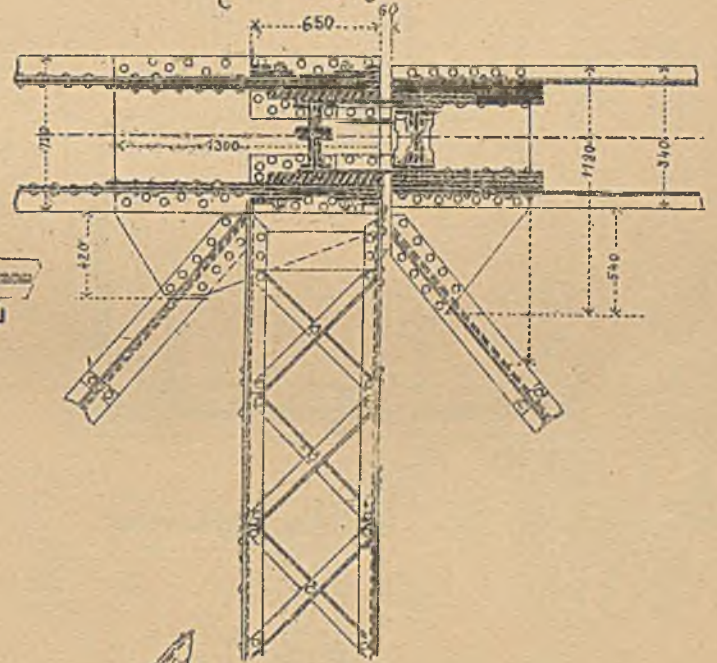

Przekrój k.l.

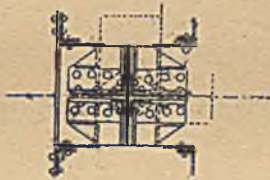

Przekrój m.v.

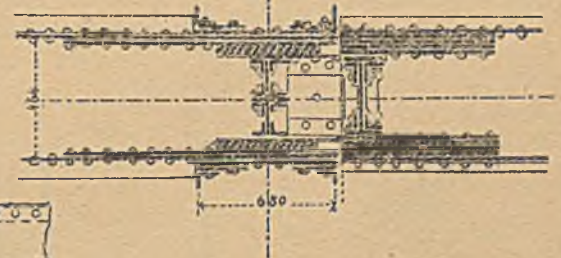

Rys. 1.

Most nad
Lechjem pod
Kuilenburgiem.
1/30 n.w.

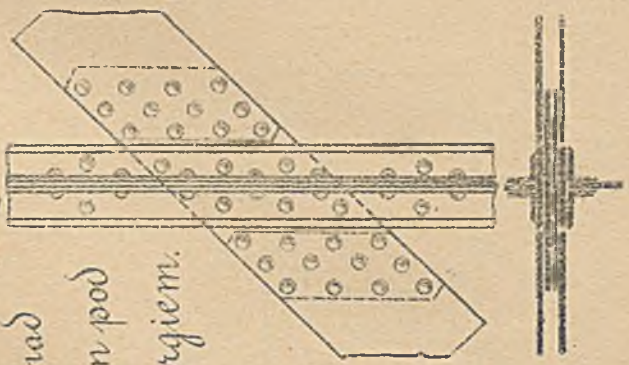

Rys. 2.

Most na
Dunaju pod
Staurham-
sen.
1/25 n.w.

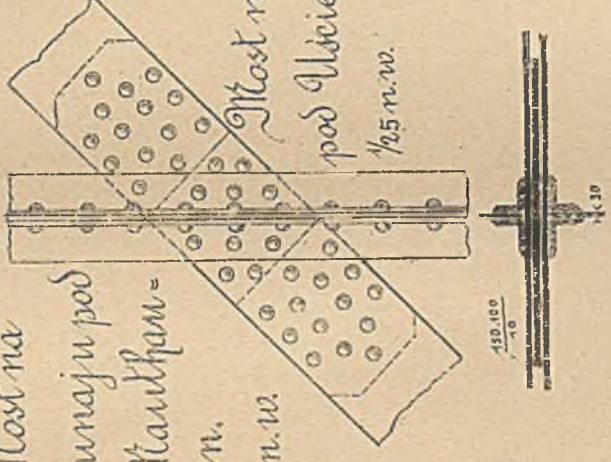

Rys. 3.

Most na
Dunaju pod
Staurham-
sen.
1/25 n.w.

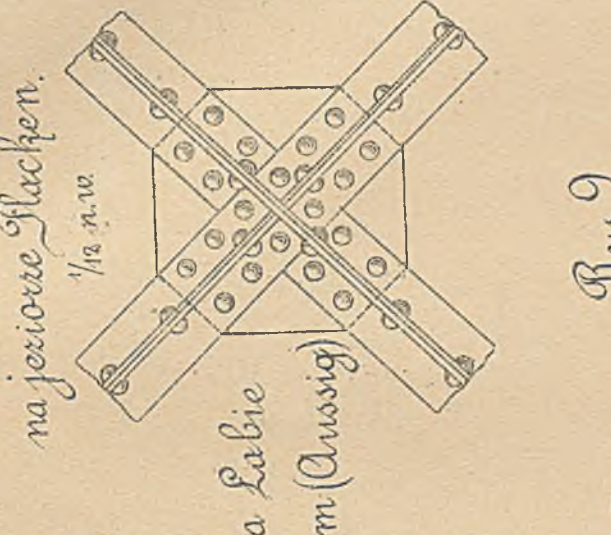

Rys. 4.

na jerozolimskie
Flaschen.
1/12 n.w.

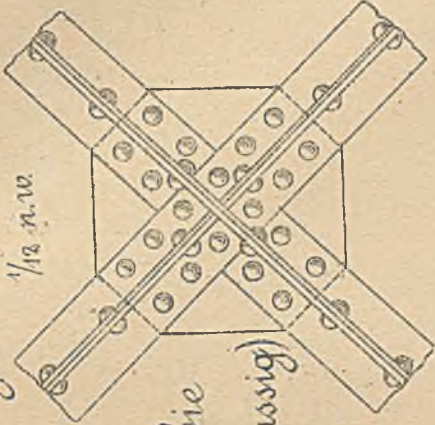

Rys. 5.

Most na
Czere pod
Busswyl.

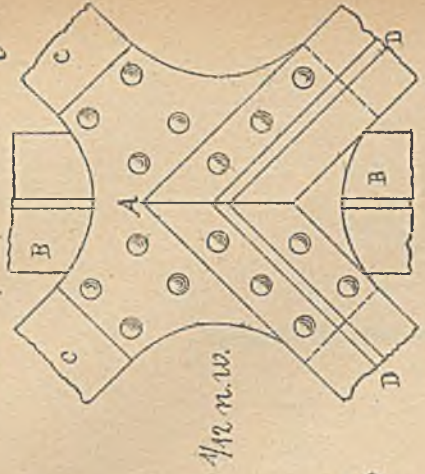

Rys. 6.

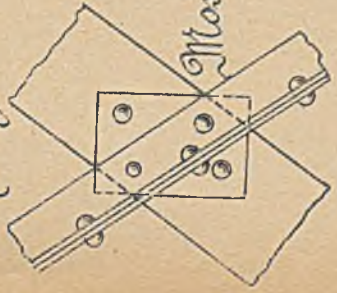

Most na Dunaju pod
Vilsofen. 1/15 n.w.

Rys. 8.

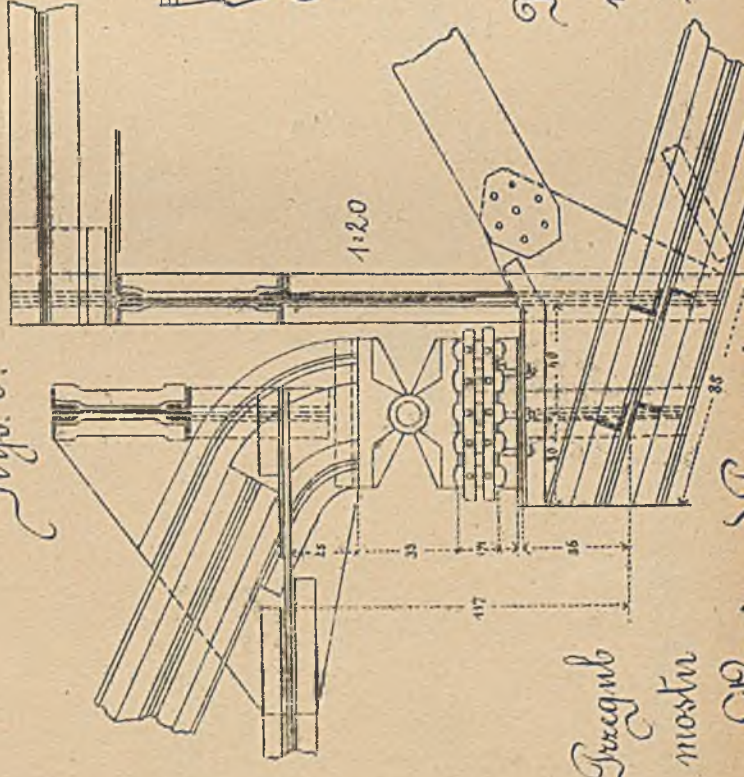

Pręgnął
mostu

na Parcie nad Tornaniem

Rys. 7.

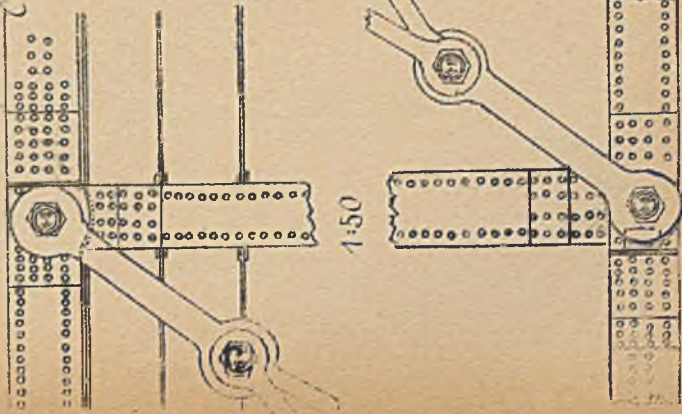

Rys. 9.

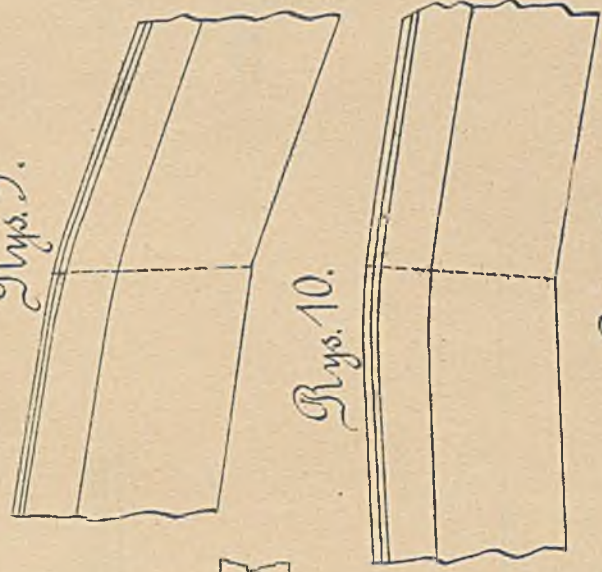

Rys. 10.



Rys. 11. a.

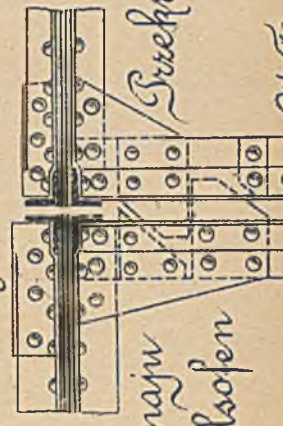

Most
na Dunaju
pod Vilsofen

Rys. 11. b.

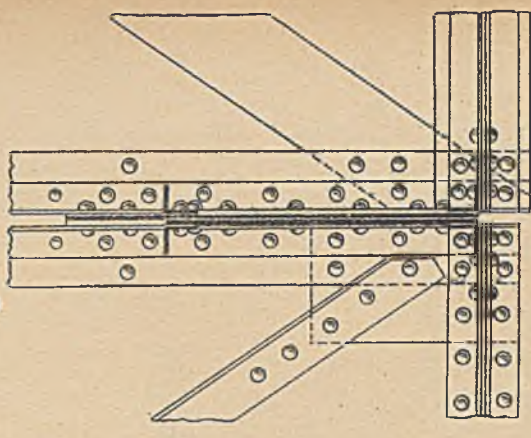

Widok pasu dolnego.

Przekrój poziomy pasu górnego.

Przekrój pionowy pasu górnego.

Podaczenie pason.

rys. 1.

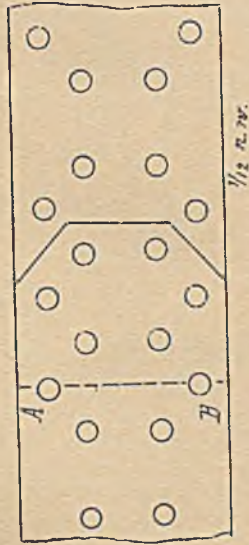

rys. 4.



rys. 2.

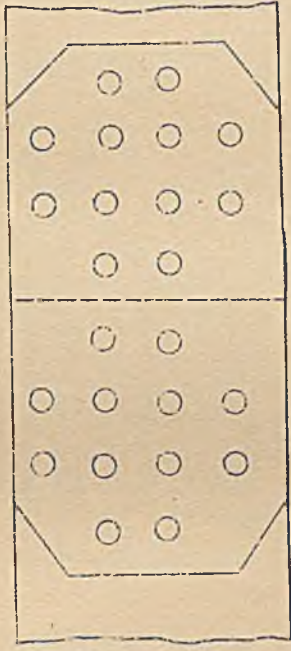

rys. 5.



rys. 7.

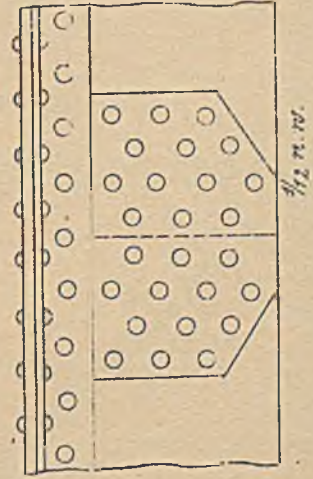

rys. 6a.

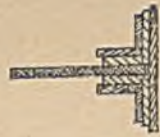

rys. 6b.



rys. 3.

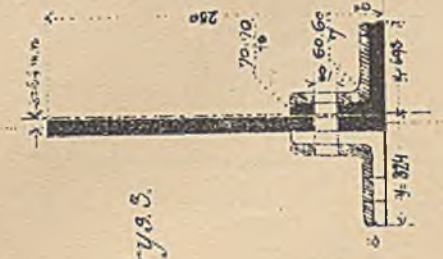

rys. 6.



rys. 9.



Podłączenia pasów z krzyżulcami.

Most na Dwiestrze w Radstowicach.

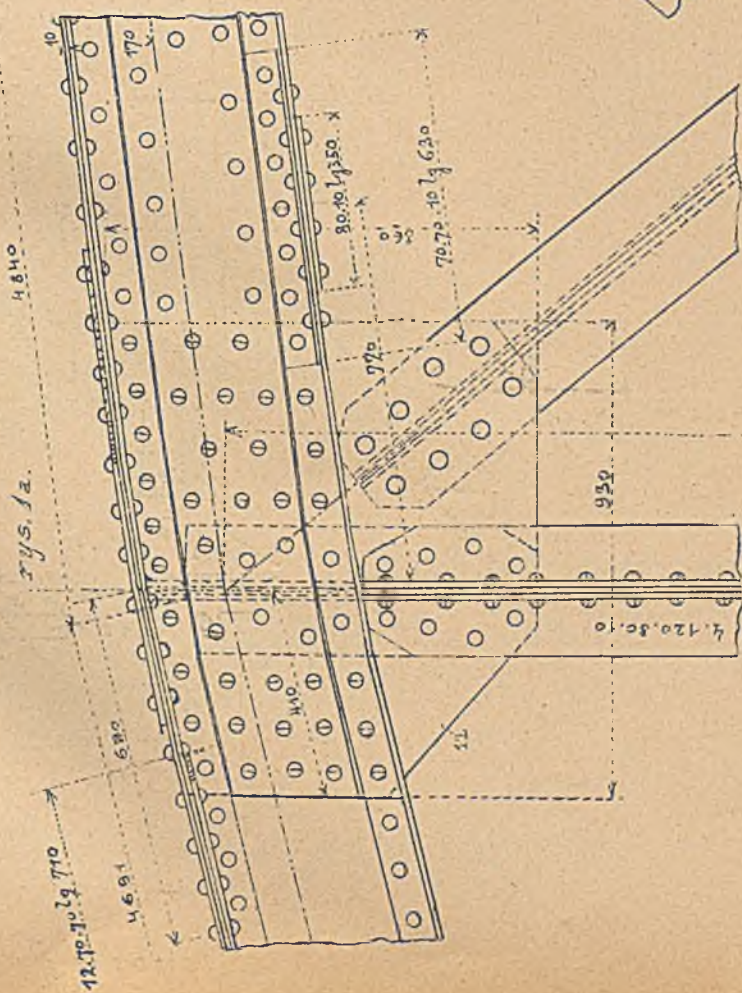

rys. 1a.

Most na Legu pod Zaleszaniem.

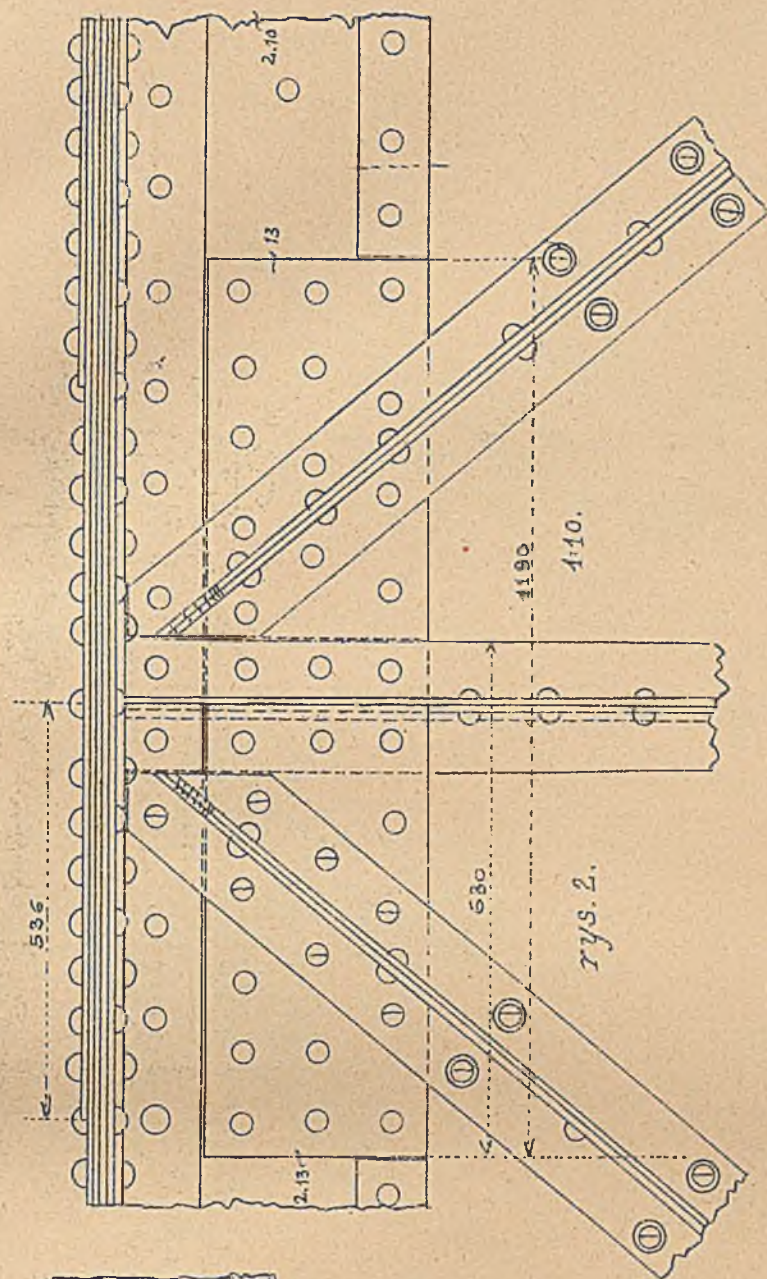

rys. 2.

1:15

rys. 1b.

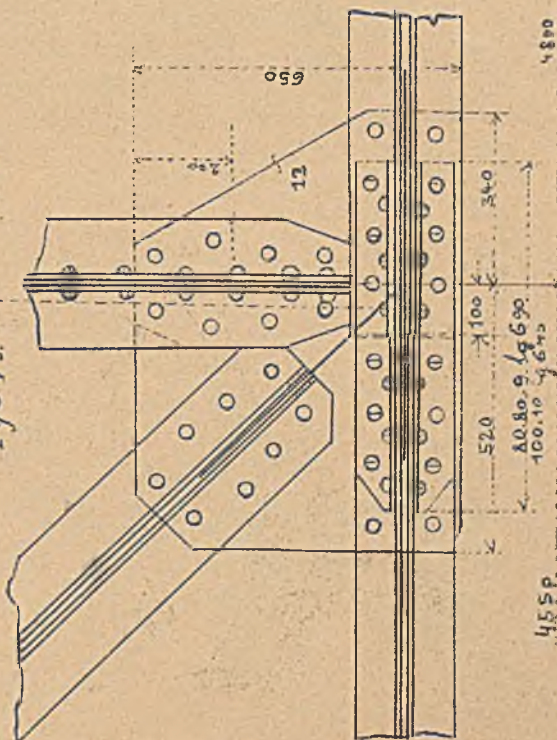

Most na Biatce między Bielskiem a Białą.

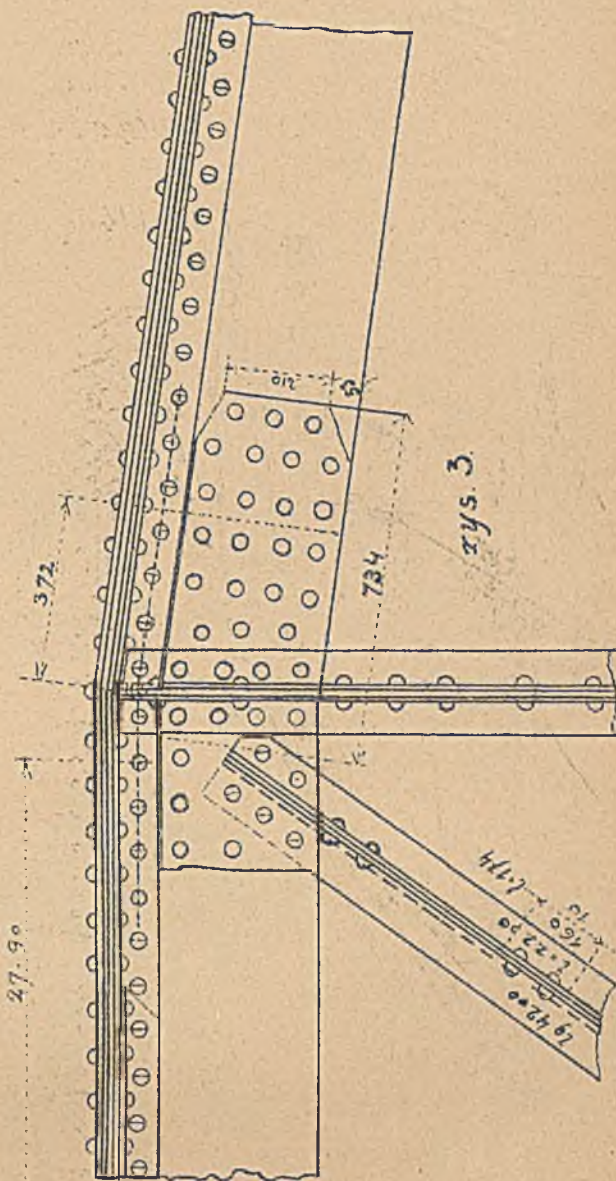

rys. 3.

Polaczenia pasow z krzyzulcami.

Polaczenia przegibne.

Tabl. 51.

Most kolei bawarskiej pod Landshut.

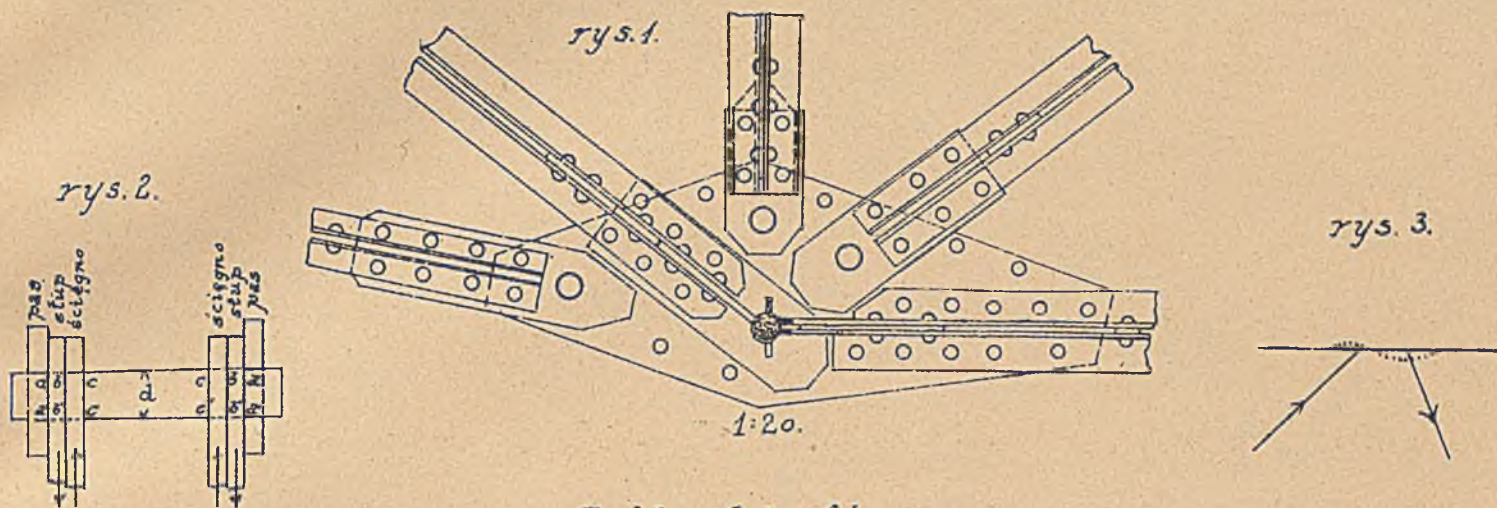

Belka Schifkorna.

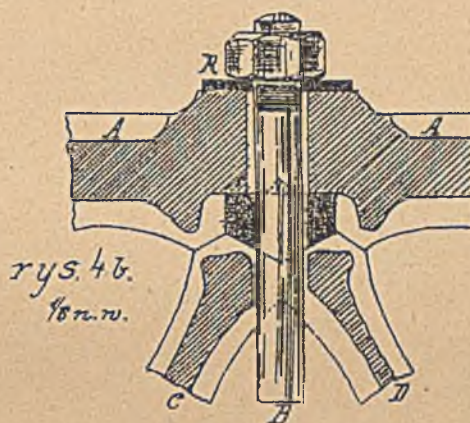
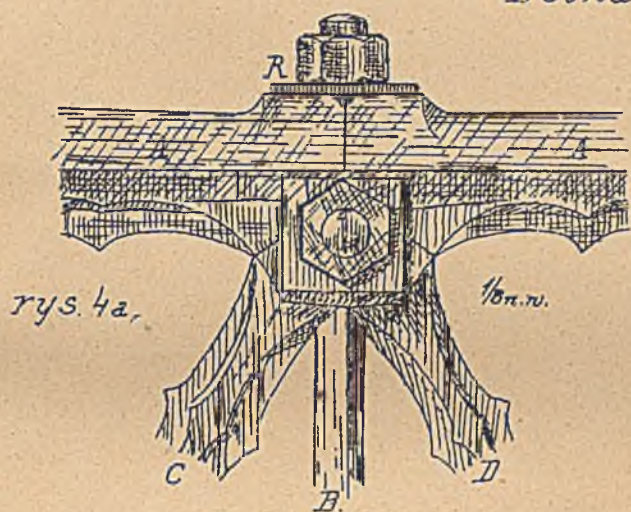

rys. 4c.

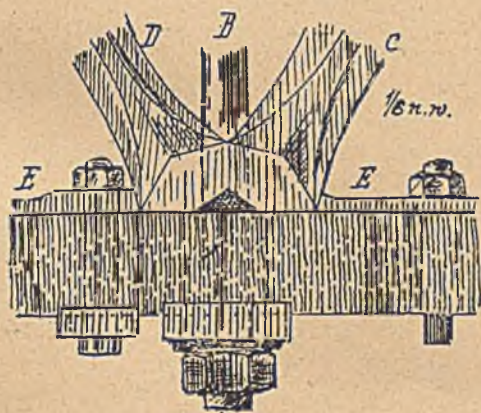

rys. 5.
1/40 n.v.

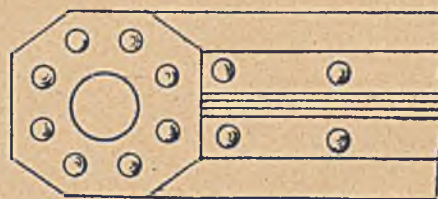

rys. 7.

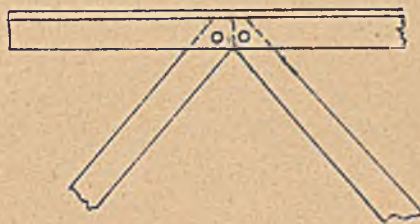

rys. 8.

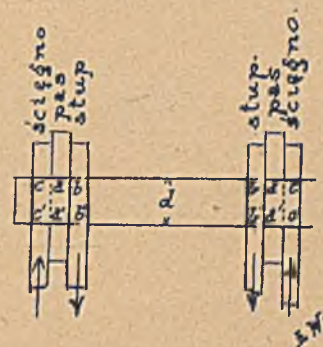

rys. 6.

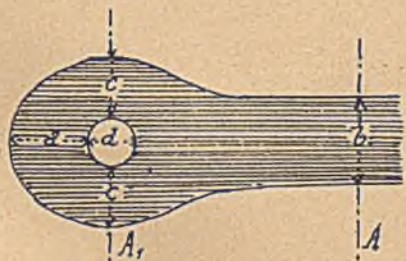

Most na Oranie pod Świątostawiem

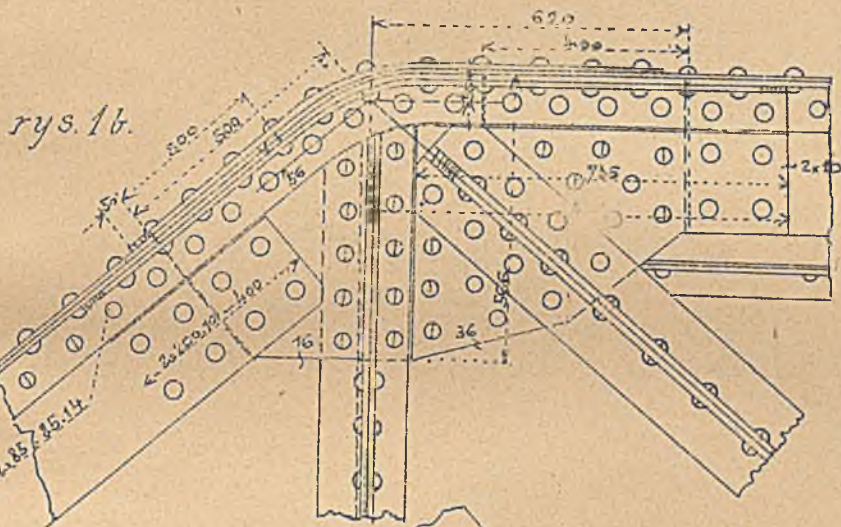
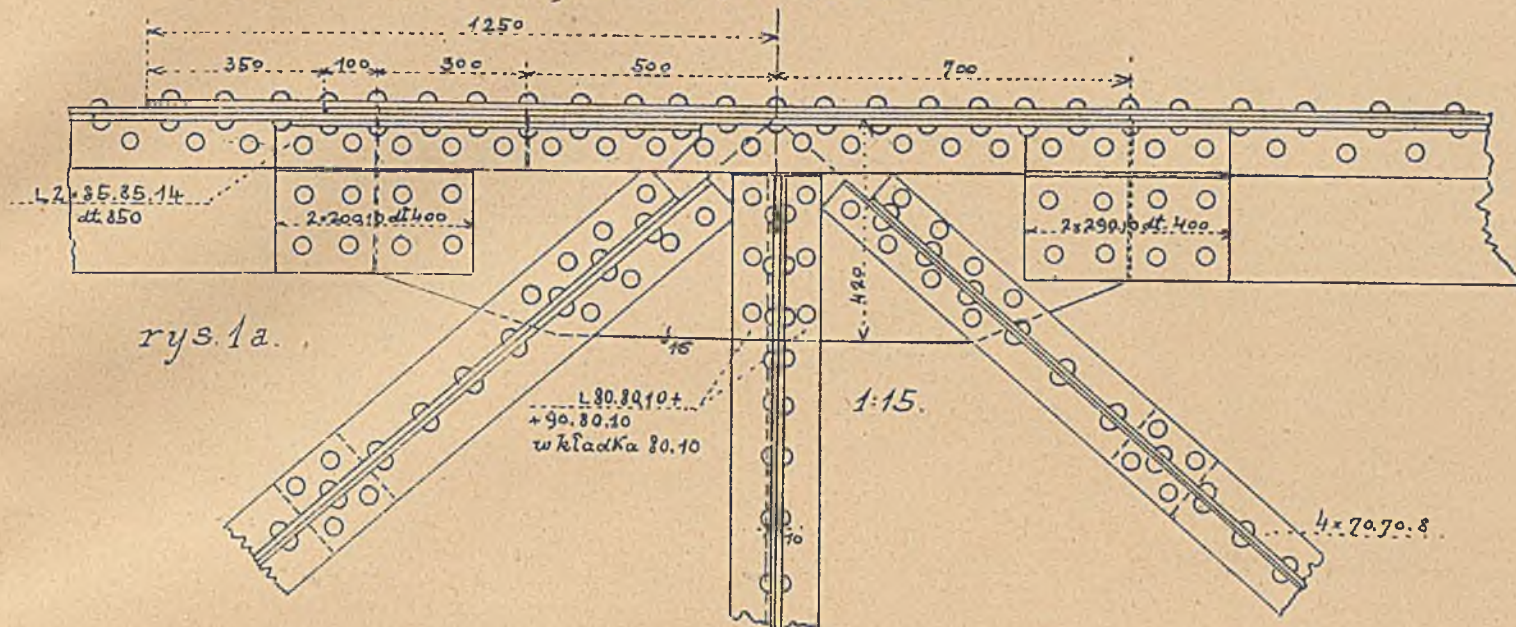

M. na Missisipi w Altonie.

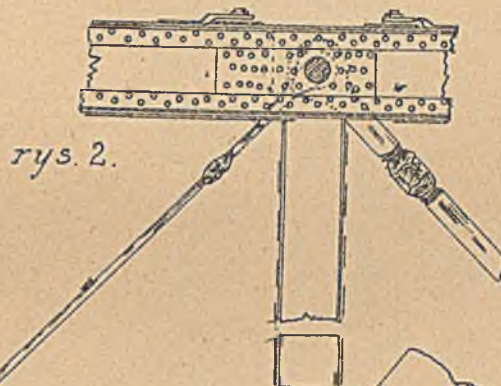

Most na Łęgu p. Zaleszanami.

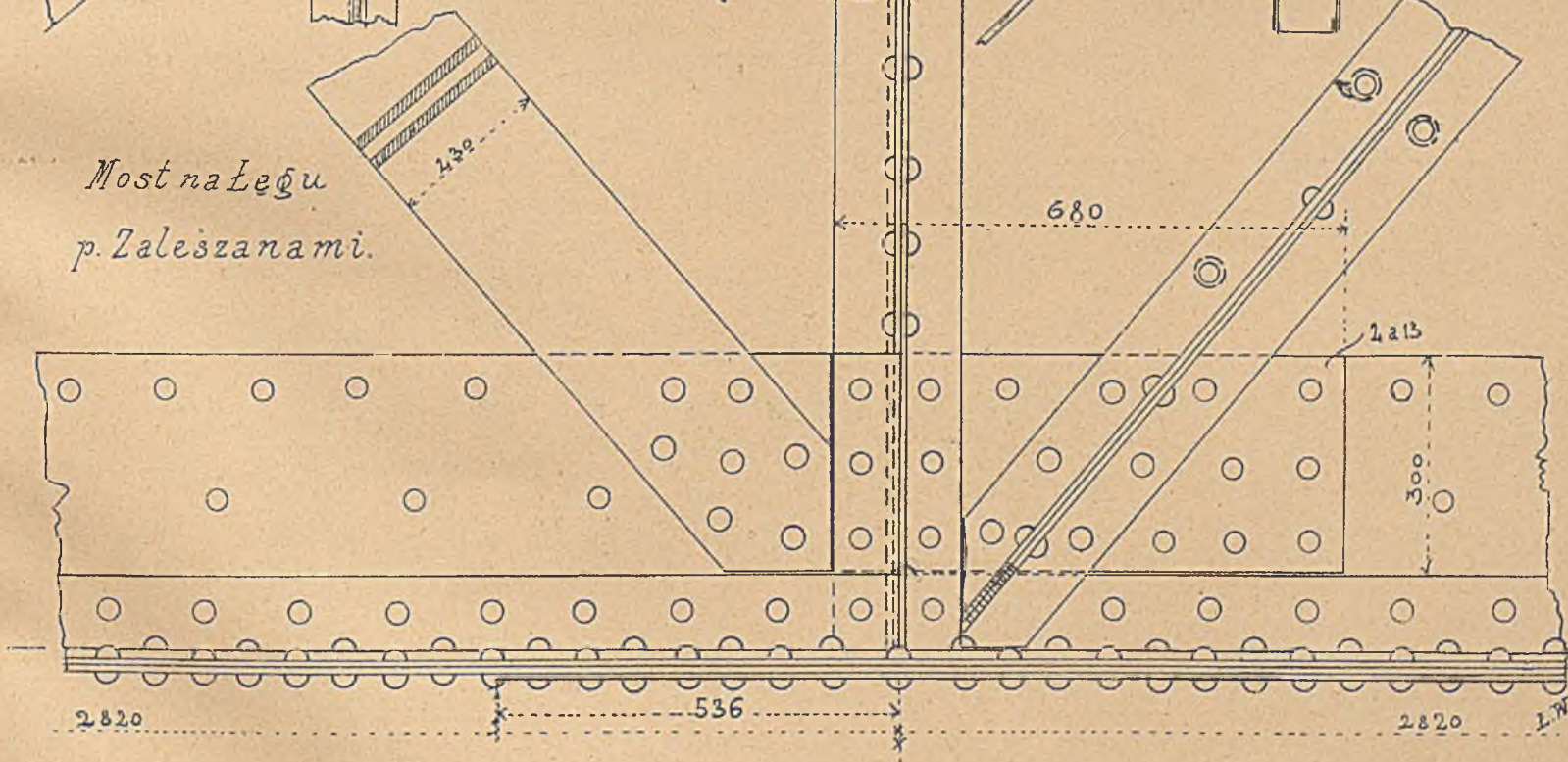

Most na Delaware pod Filadelfią.

rys. 1a.

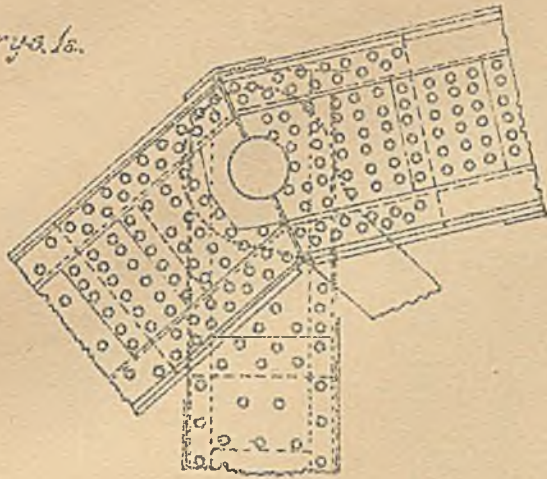

rys. 1b.

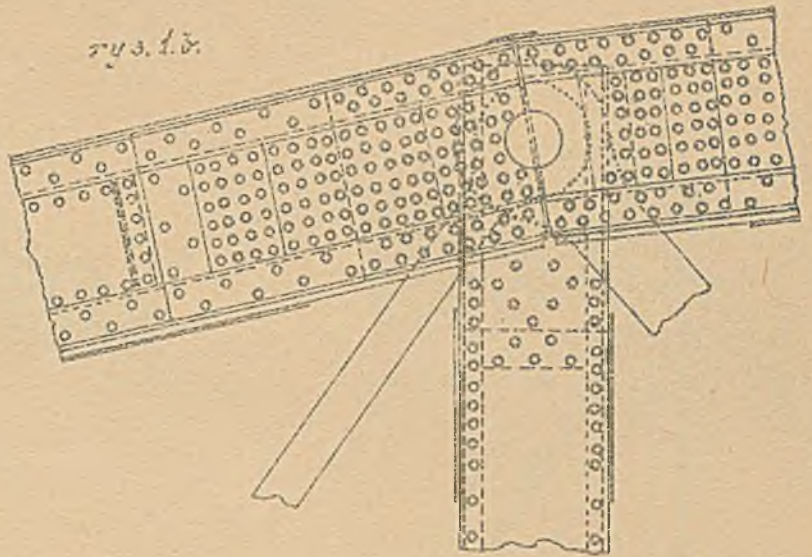

rys. 2.

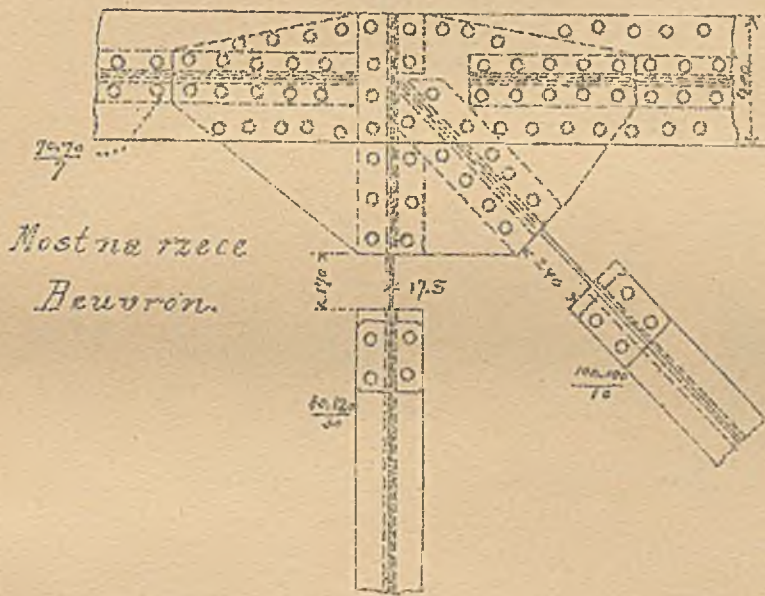

rys. 1c.

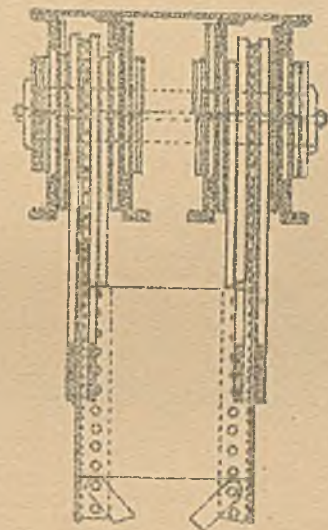

rys. 3.

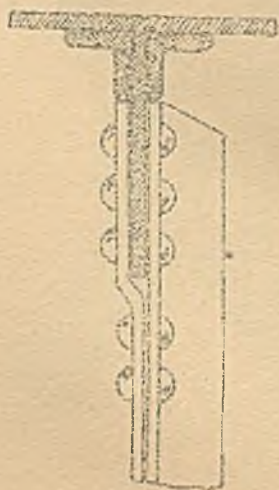

Most na Bystrzyicy w Stanisławowie.

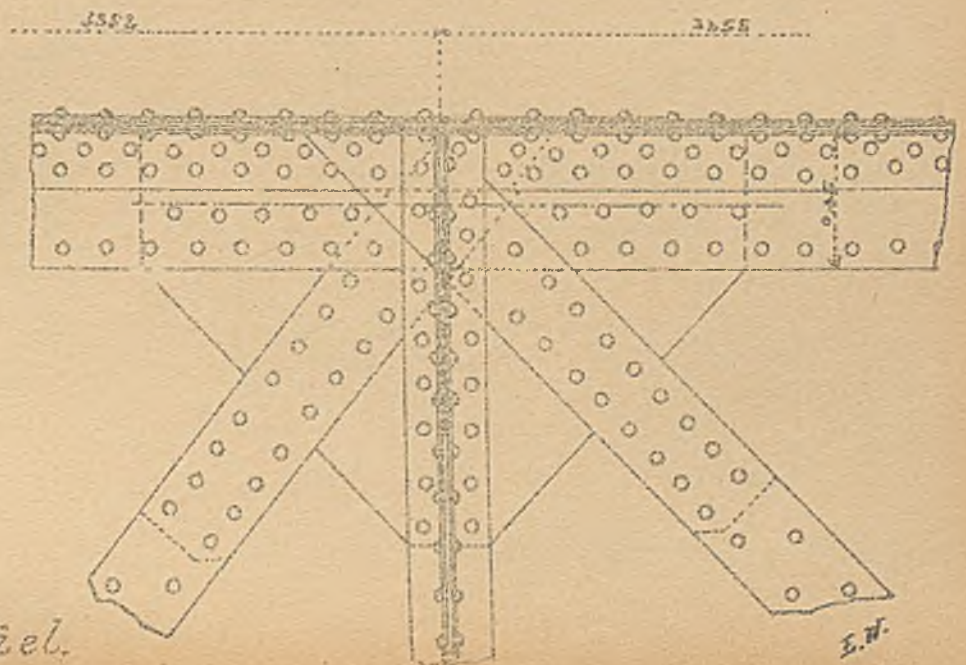

Most na Salzach pod Oberndorf.

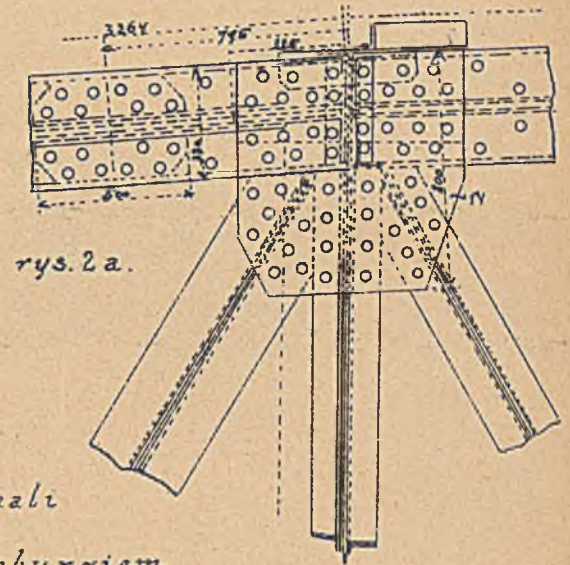
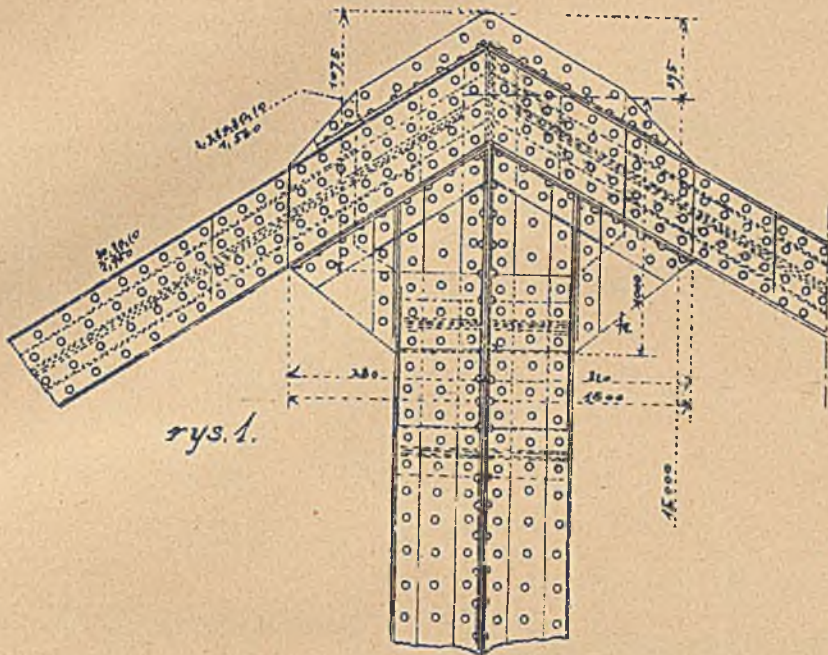

Most na Saali pod Bernburgiem.

Most na Mozeli pod Koblenca.

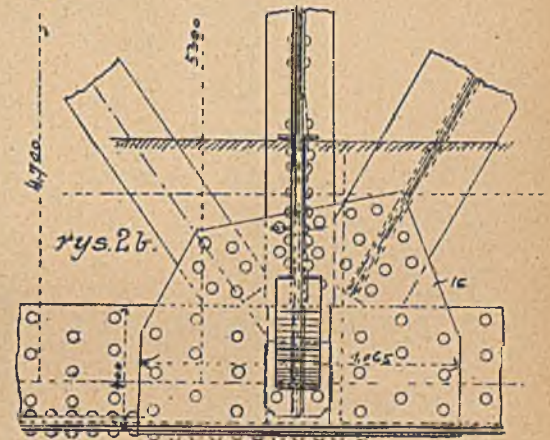
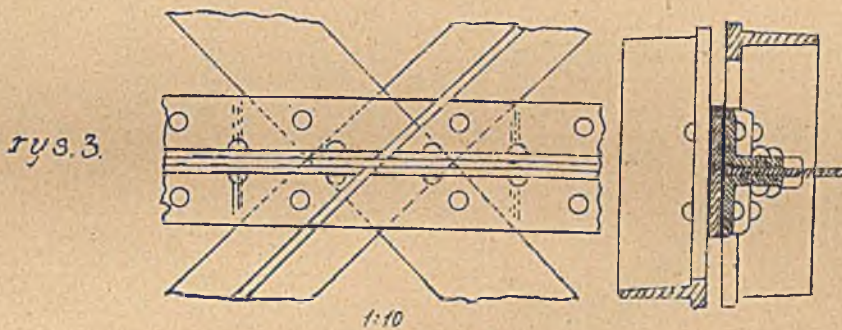

Belka Schiffkorna.

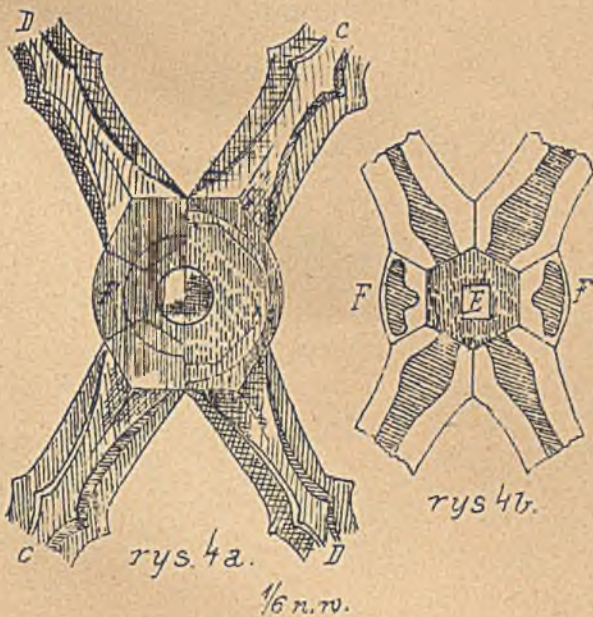

rys. 5.

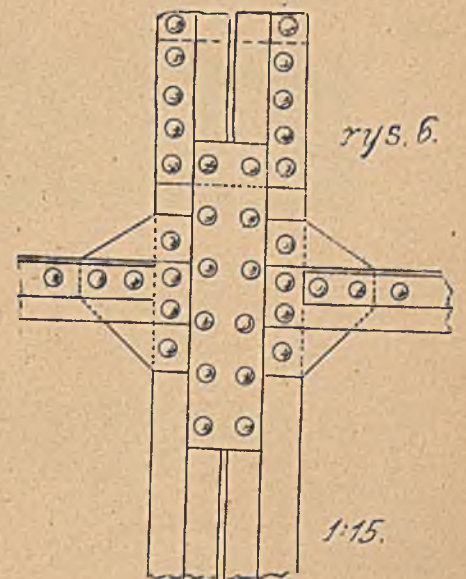
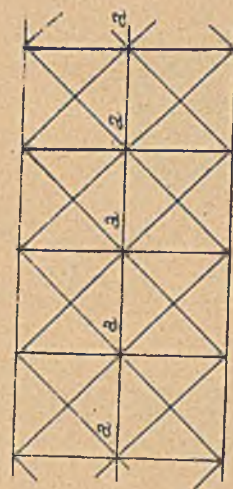

Most na Renie w Moguncyi.

Most ton. Harkort.

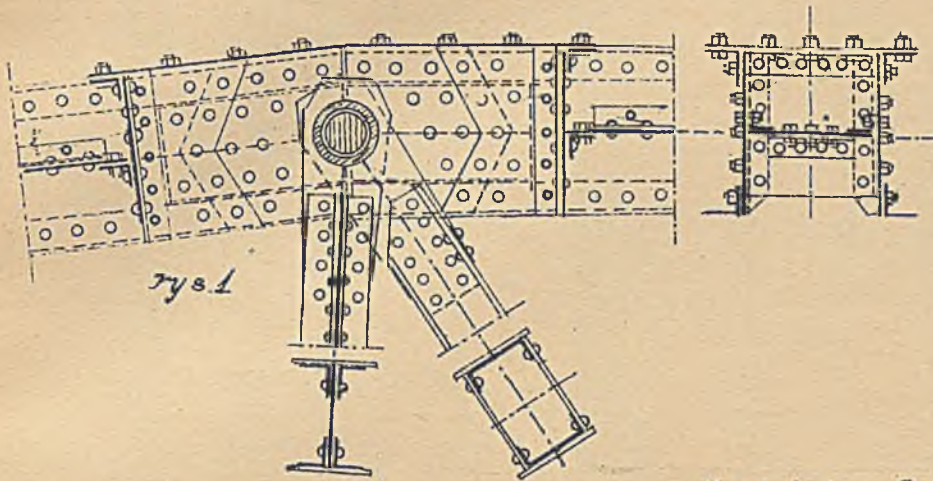

M. na Renie kolei Winterburg-Kreuzlingen. rys. 2.

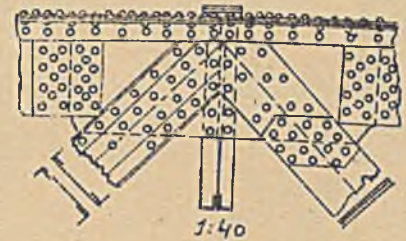

rys. 5.

Most kolei Saint Aignan Blois.

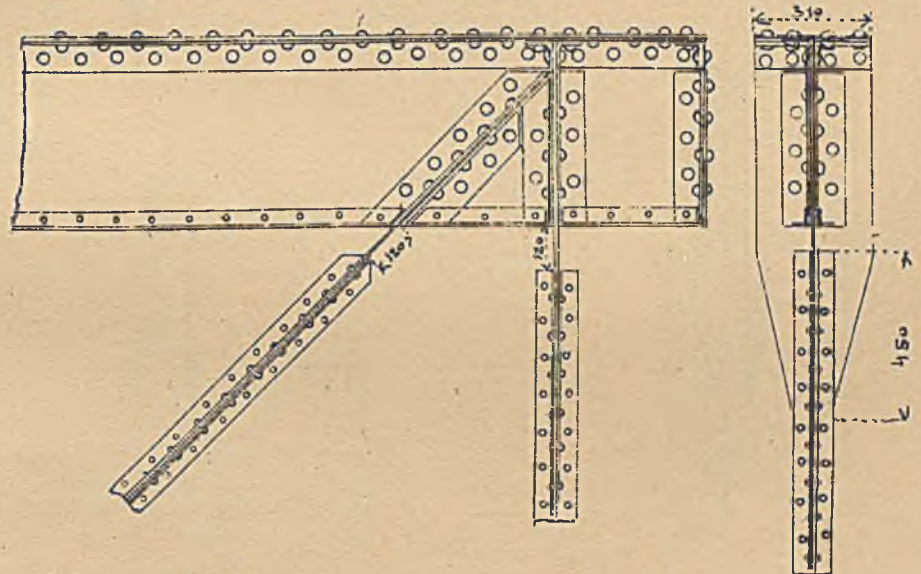

M. na Mozeli p. Diedenhofen. rys. 3.



rys. 4.

Most na Forth.

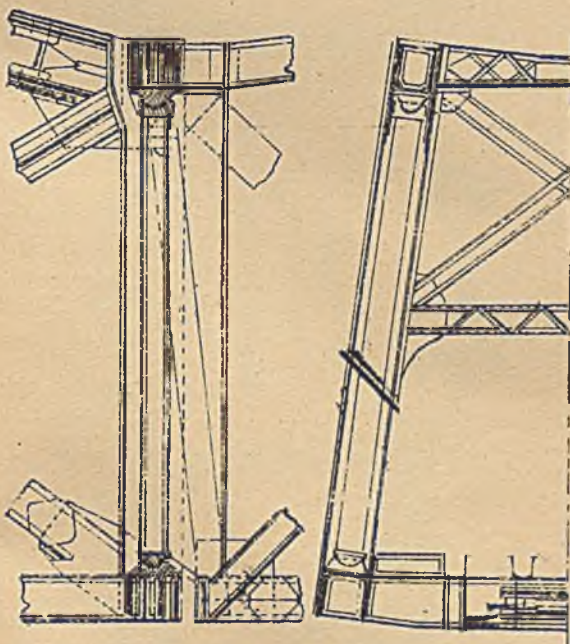

rys. 6.



rys. 7.

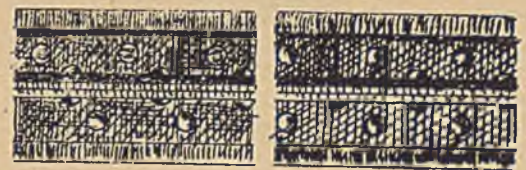

rys. 8.



Styk ścianki stojącej.

rys. 1.

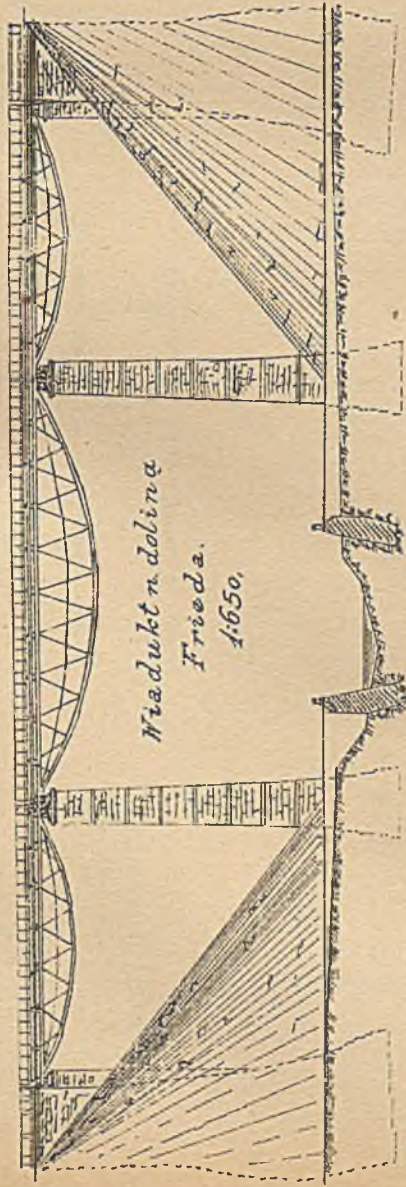

rys. 3.

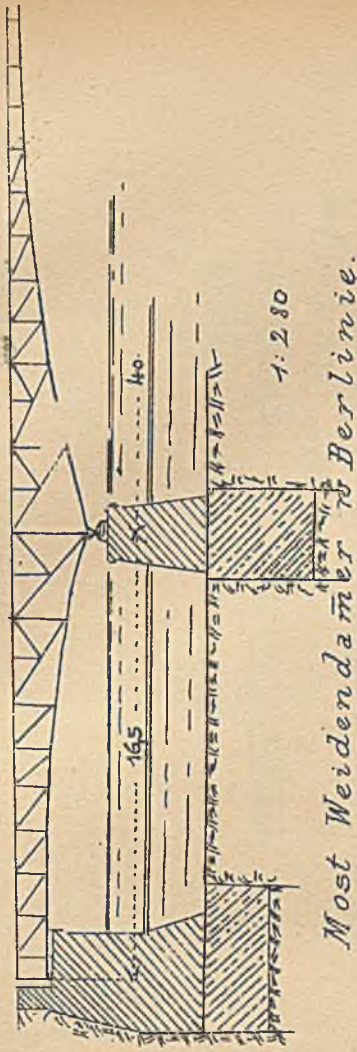

rys. 2.

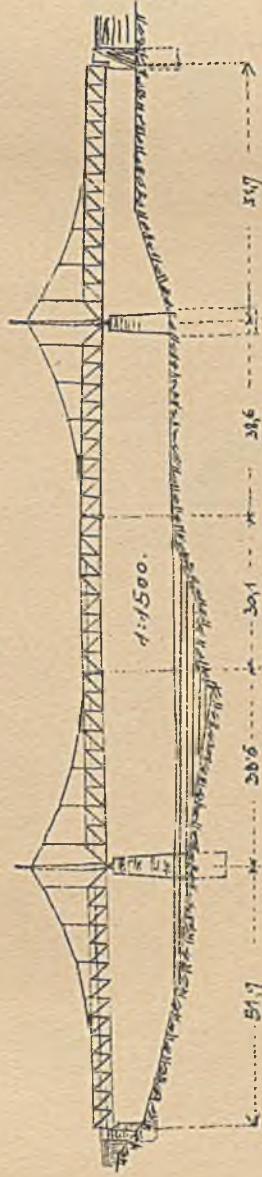

Most drogowy na Cisie pod Tokajem.

rys. 5.

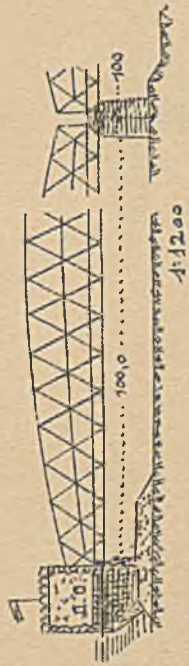

M. na Wisle pod Fordonem.

rys. 6.



M. kol. transwers. w Galicyi.

rys. 7.



M. na Lecku p. Kuillenburgiem.

rys. 4.



Most pod Czernow na Weltawie.

rys. 8.

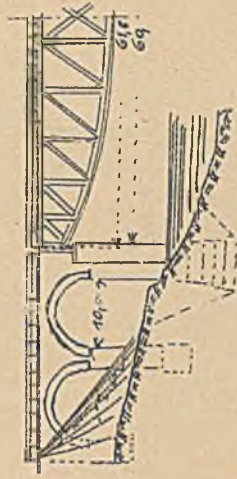

M. karulańskiej na Innie.

rys. 4b

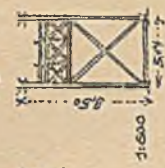

rys. 1



rys. 3

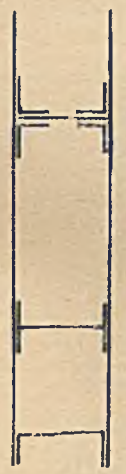

rys. 5

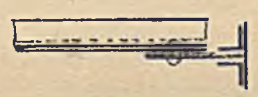

rys. 6



rys. 7



rys. 2



rys. 4

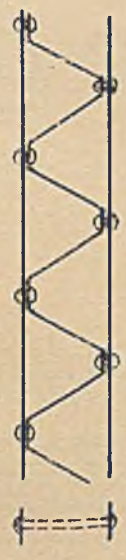

M. na Reuch p. Oberkirchen.

rys. 8



M. na Granie na Węgrzech.

rys. 9



M. k. południowej.

rys. 10



W. na Tapée.

rys. 11



Wiadukt Crumlin.

rys. 13



rys. 15

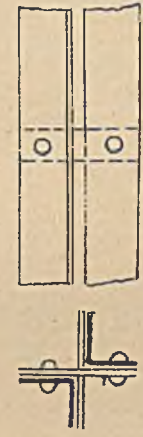

rys. 16

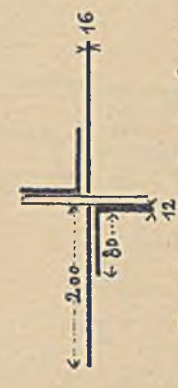

M. k. półn. zachodniej. W. na Dyji p. Znaimem.

M. na Lechu p. Kaufering.

Dz. M. Thullie: Mosty kratowe żelazne.

M. Eisenst.

Przełupy w belkach wspornikowych.

Tabl. 58.

rys. 1

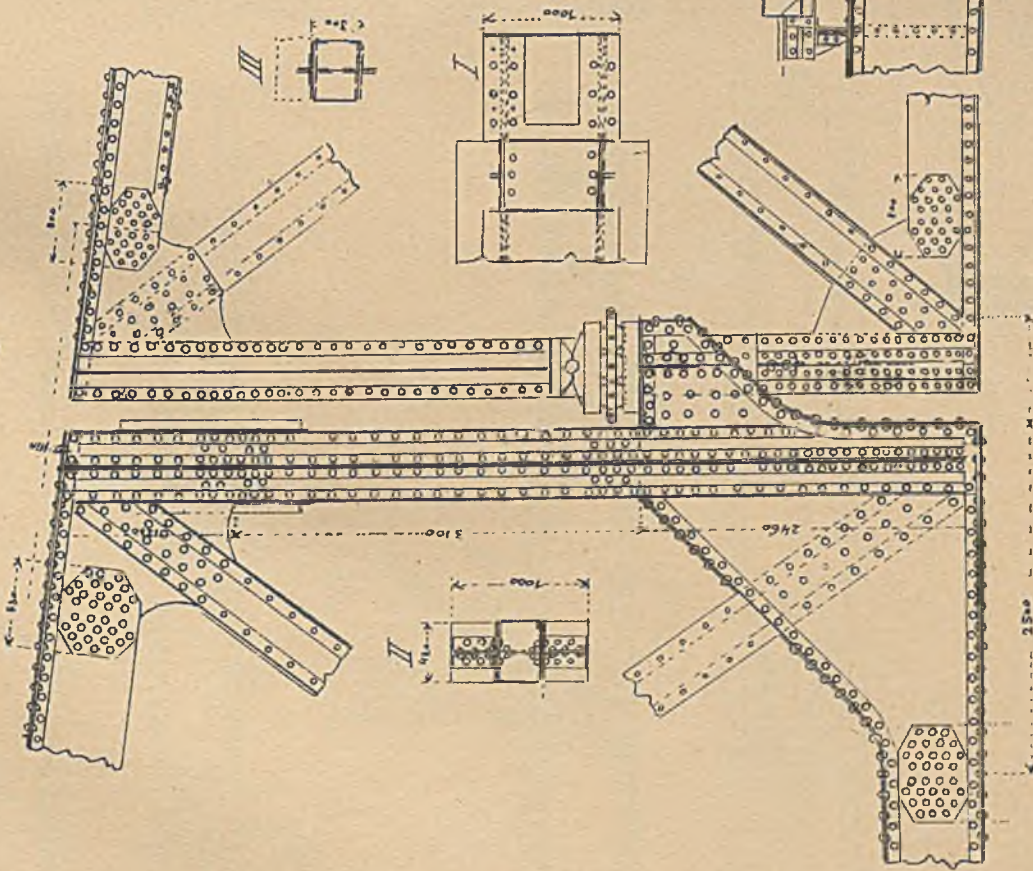

WIDOK

*Przełup mostu na Dunaju
w Peszcie.*

Dr. M. Thullie: Mosty kratowe żelazne.

rys. 2.

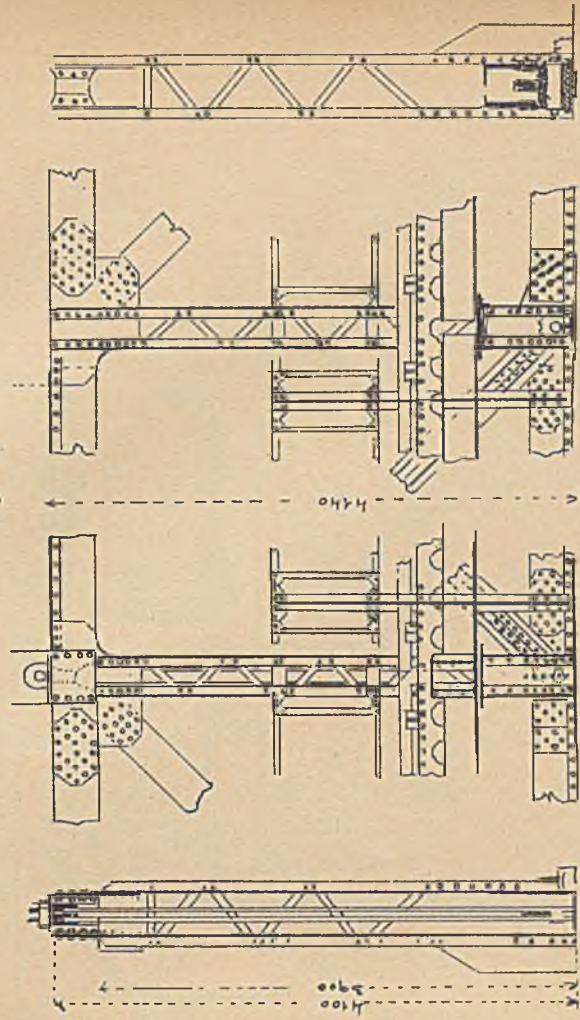

Z mostu na Cisie pod Takajem

rys. 3.

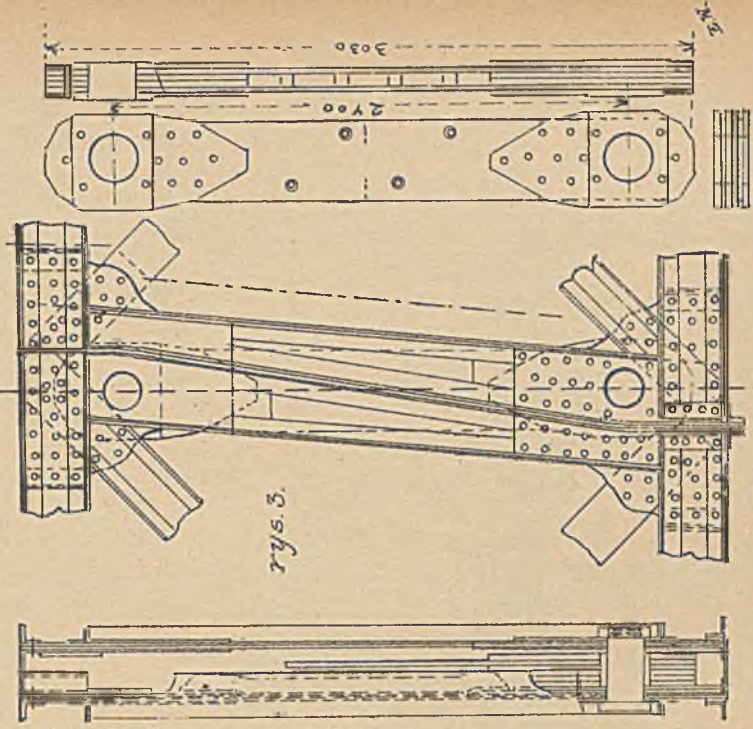

Przełup m. na Conway w Tal-y-cafn.

rys. 4.

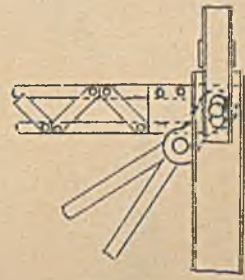

Most na rzece św. Jana

PRZYKŁAD

rys. 1.

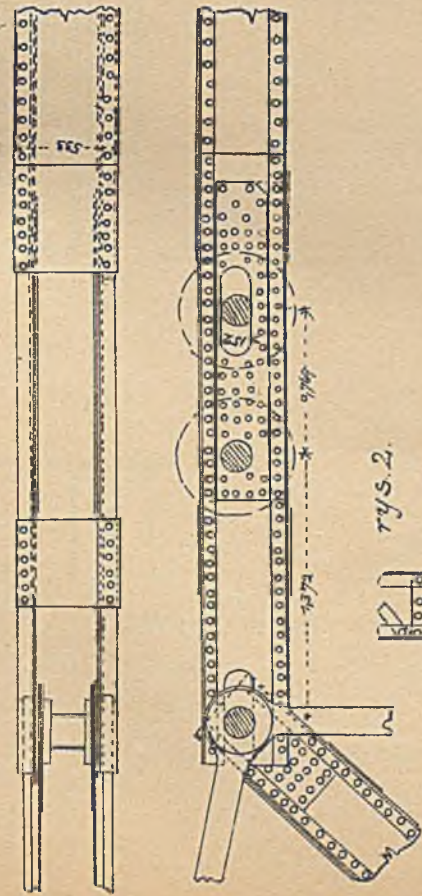

Przełęby mostu wspaniętego na Orlu w Cincinnati. (rys. 12)

rys. 2.

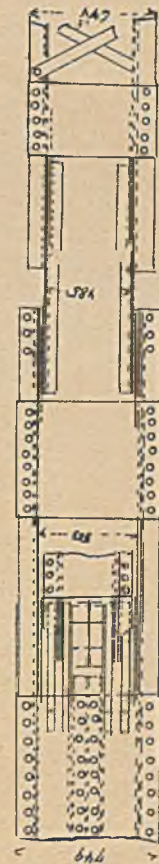
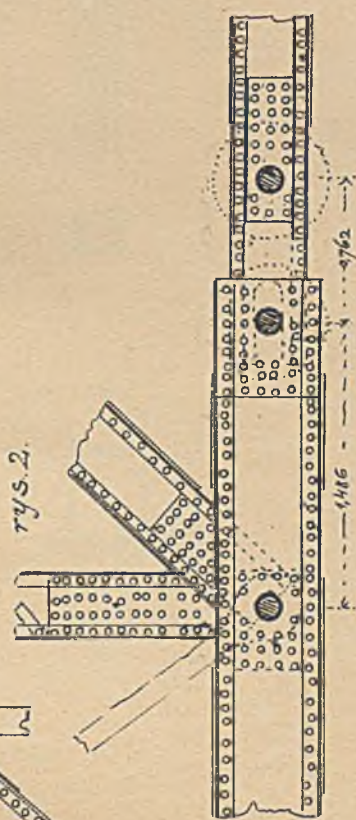

rys. 5.

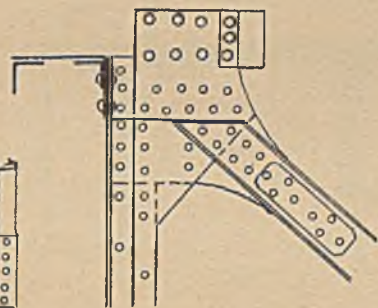

D. M. Thullie.

Mosty kratowe żelazne.



P. mostu kol. miej. w Berlinie.

rys. 3.

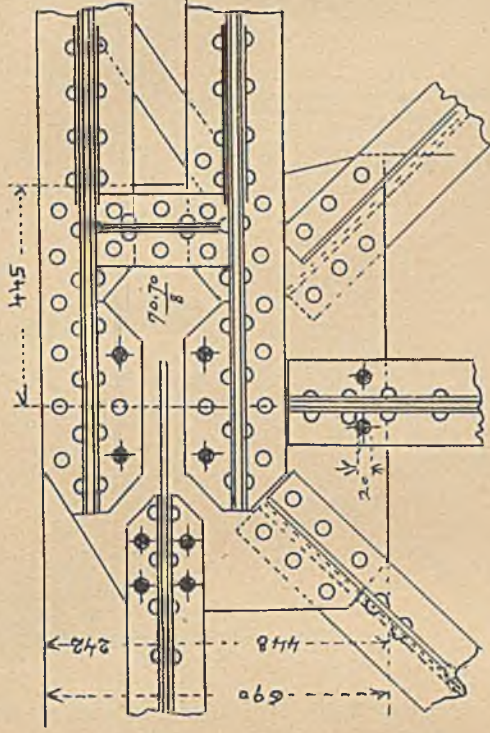

Przełub mostu na Odrze

pod Studzienicom (rys. 3 i 4)

rys. 4.

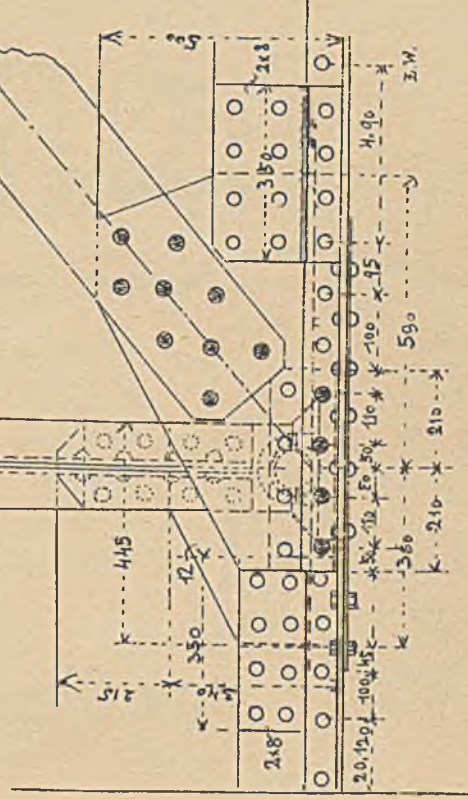

rys. 1.

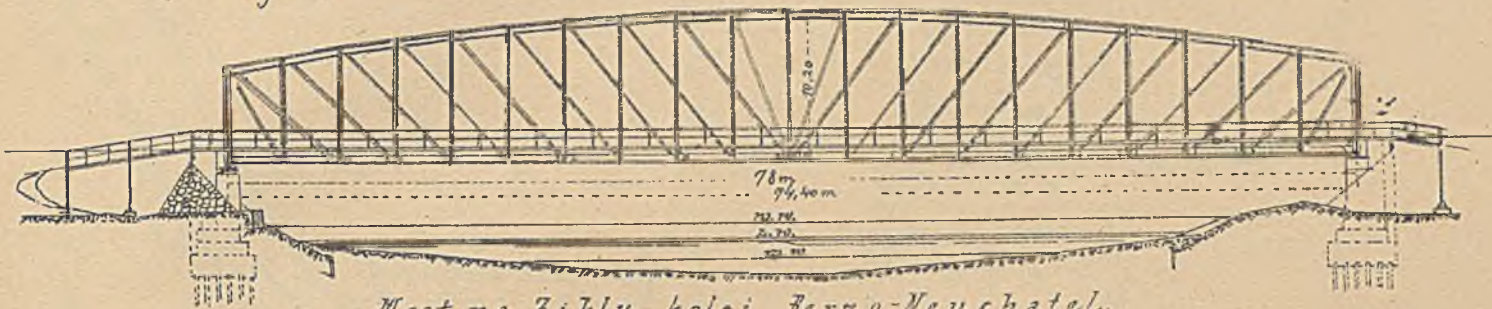

Most na Ziklu kolei Berno-Neuchatel.

rys. 3.

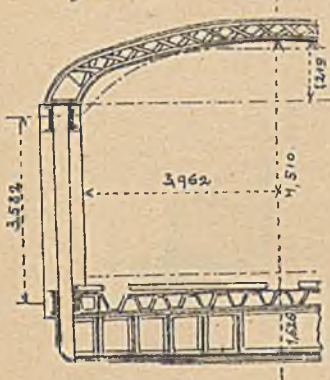

M. kol. midlandzkiej na Trancie.

rys. 4.

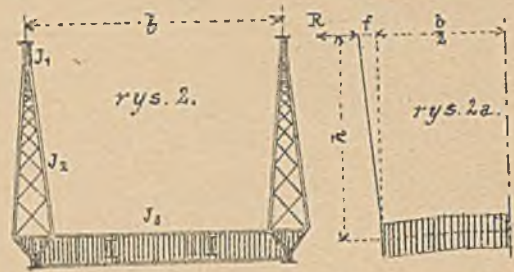

rys. 2b.

rys. 2c.

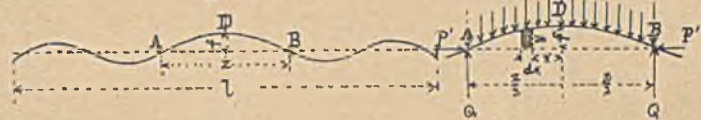

rys. 5.

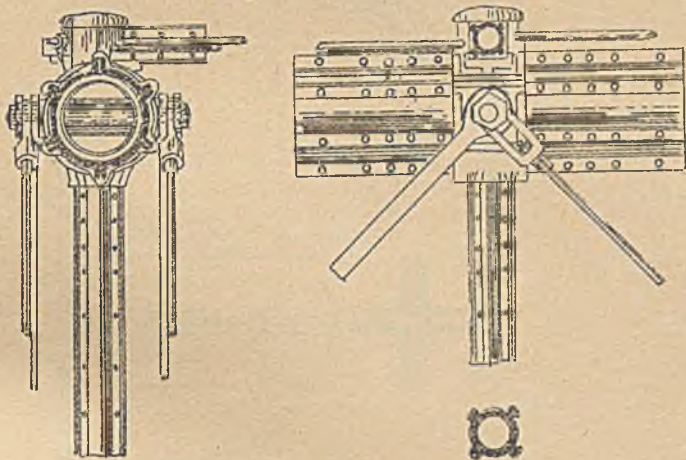

Pas amerykański.

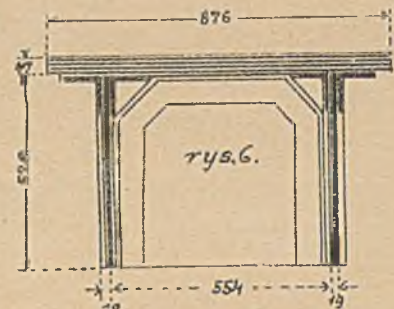

Most na Inie pod Pasoana.

rys. 8.

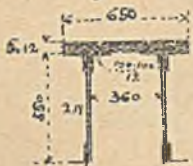

Most Maryi Waleryi na Dunaju p. Ostrzychomiem.

rys. 8a.

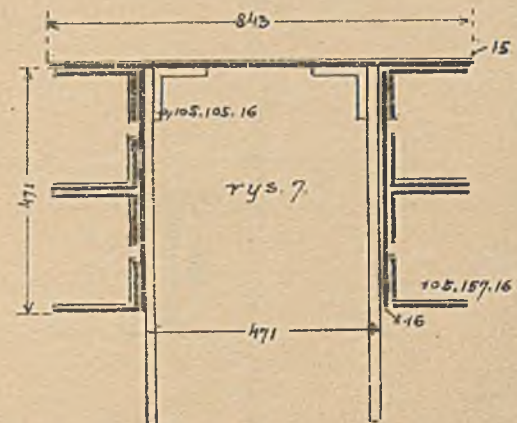

Most na Labie p. Dómitx.

Krzyżulce i potężnienia z pasami.

Tabl. 61.

rys. 1.

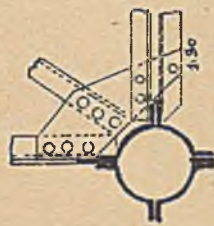

M. Tegelhoffe w Niedmju.

rys. 2.

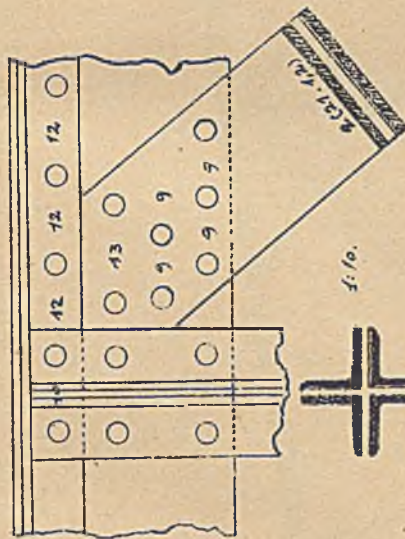

M. k. Elsbety nadworcu w Niedmju.

rys. 3.



M. na Veege w Szamajcarzy.

rys. 4.

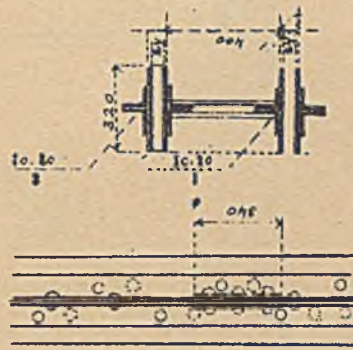

Niedmki Kerako na Węgrzech.

rys. 7.

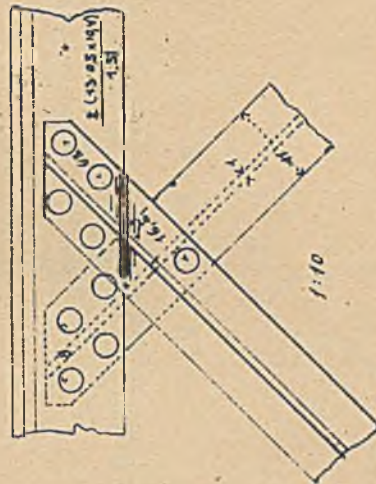

Most na Wiedence w Penzing.

Most na dworcu kol. Elsbety w Niedmju.

rys. 5.



rys. 1.

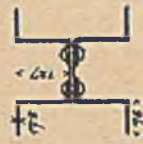

M. na Saarze w Saarbrücken.

D. M. Thullie: Mosty kratowe żelazne.

rys. 6.

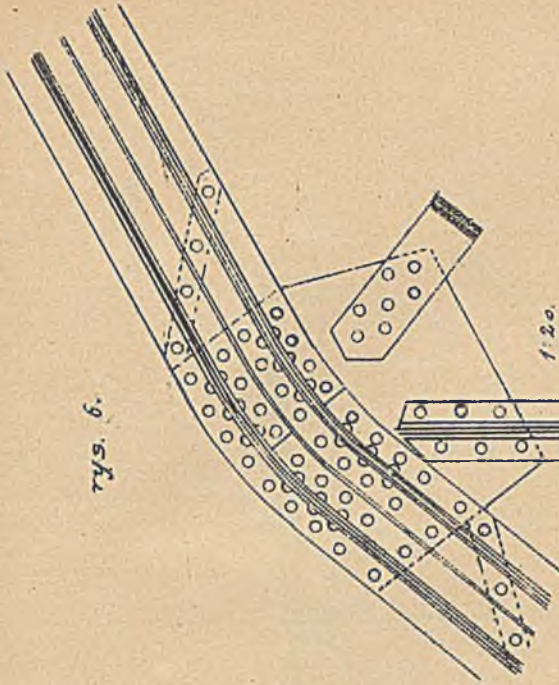

M. Schwedlera kolei dalmatyjskiej.

rys. 9.

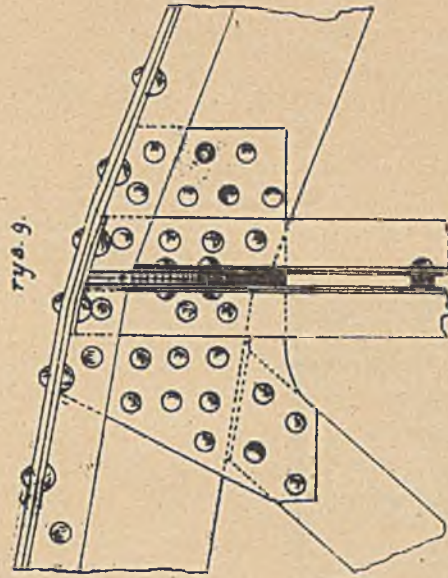

Most na Brdnie w Bydgoszczy.



Крыжувце і по'ляччэння з пасамаі.

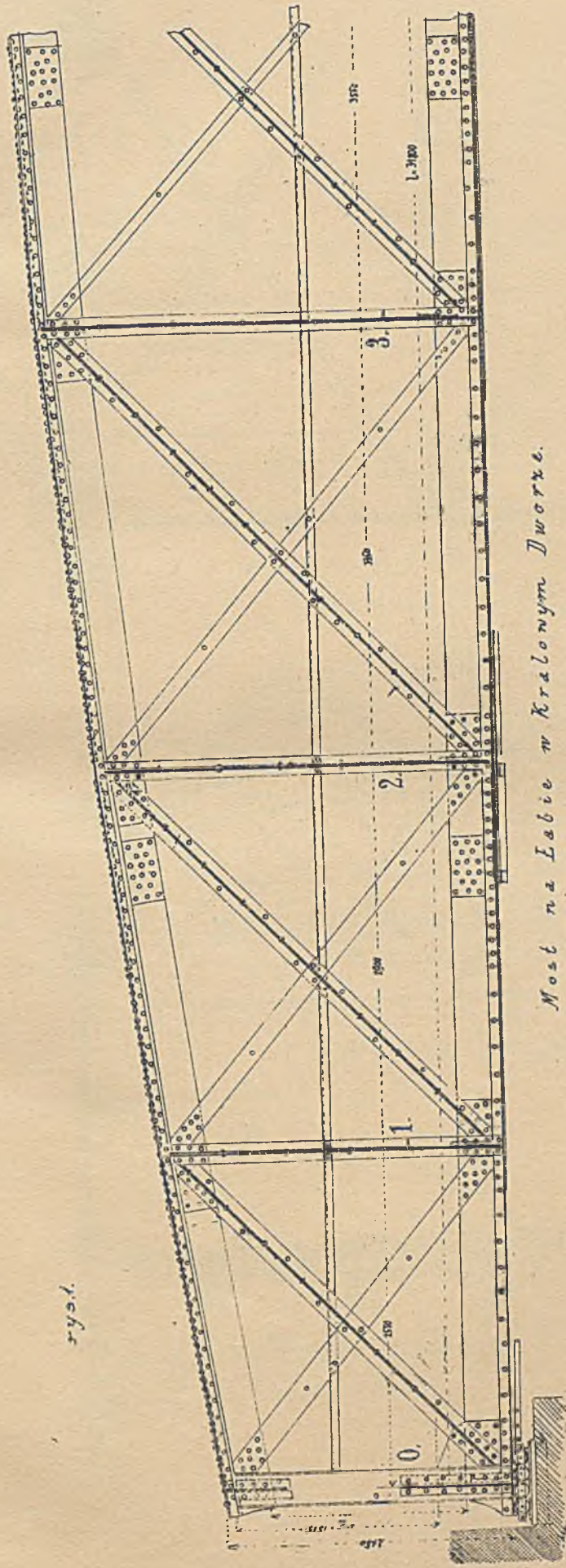

Most na Labie w Kralonym Dworze.

rys. 3.

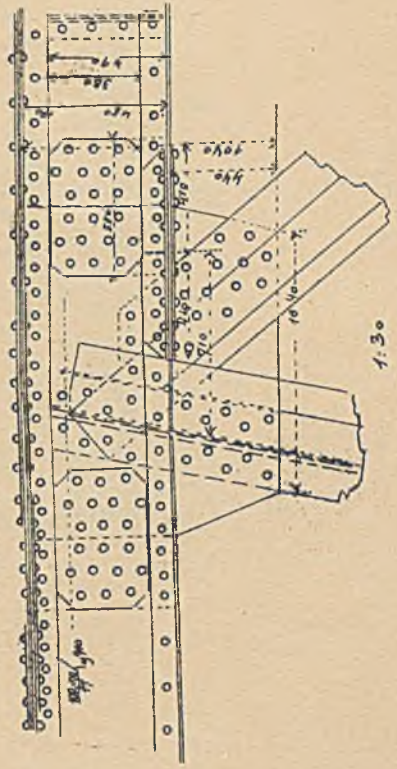

M. na Dunaju między Stein a Mautern.

rys. 2.

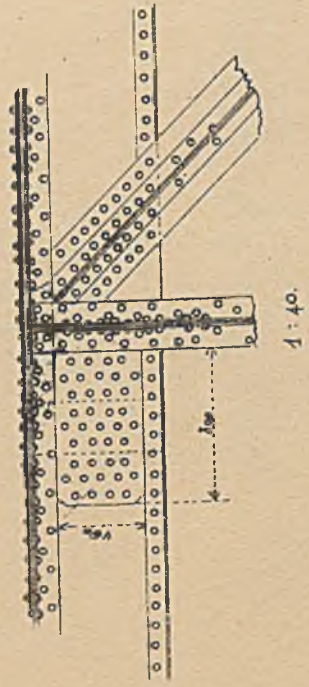

Wodoukt Marako na Negrzech.

Dr. M. Thullie: Mosty kratowe zel.

Most drogowy na Ohrzy w Fürstentumie.

Belka główna.

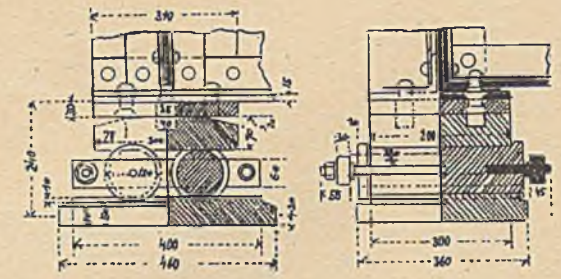

Łożysko ruchome.

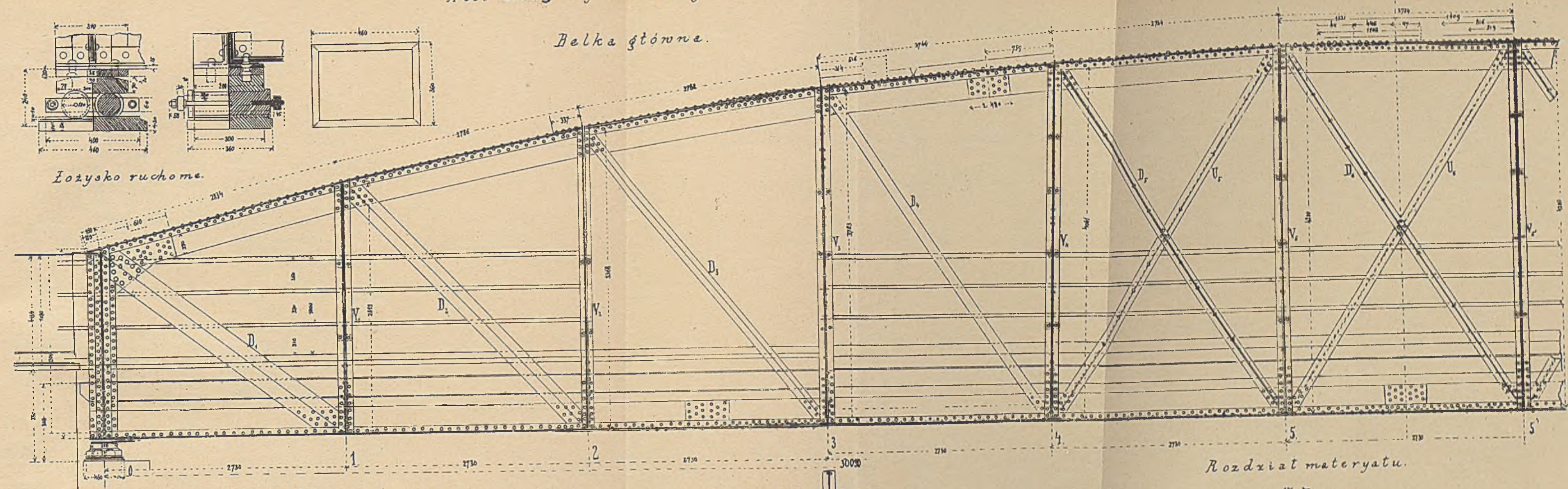

Rozdział materjatu.

Teżniki poziome.

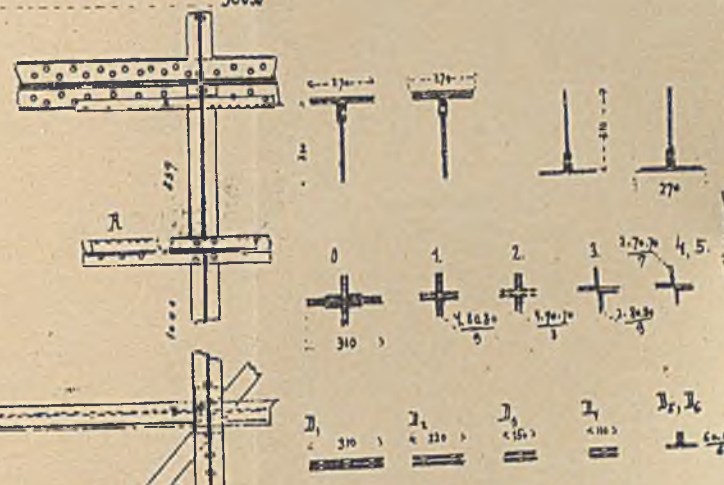
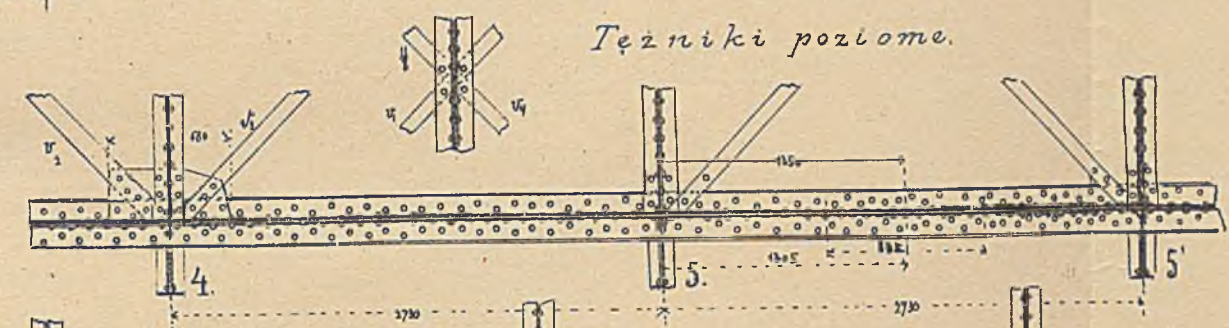

Przekroje.

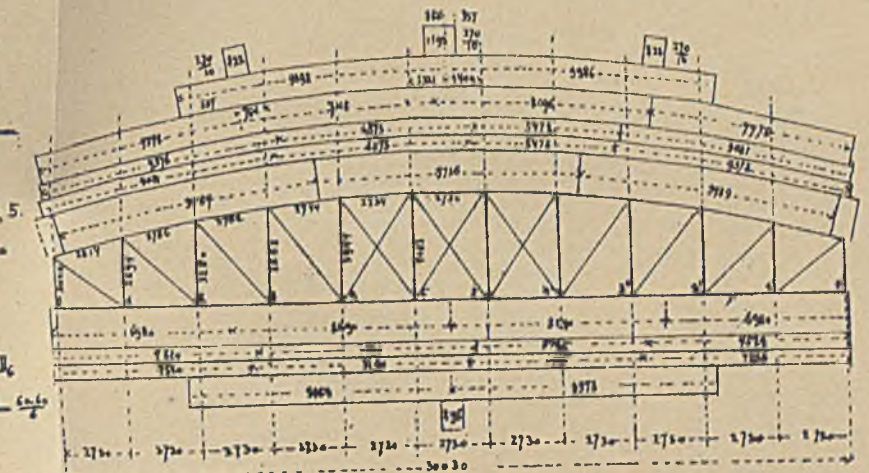

Przekroj poprzeczny na kraju. w środku.

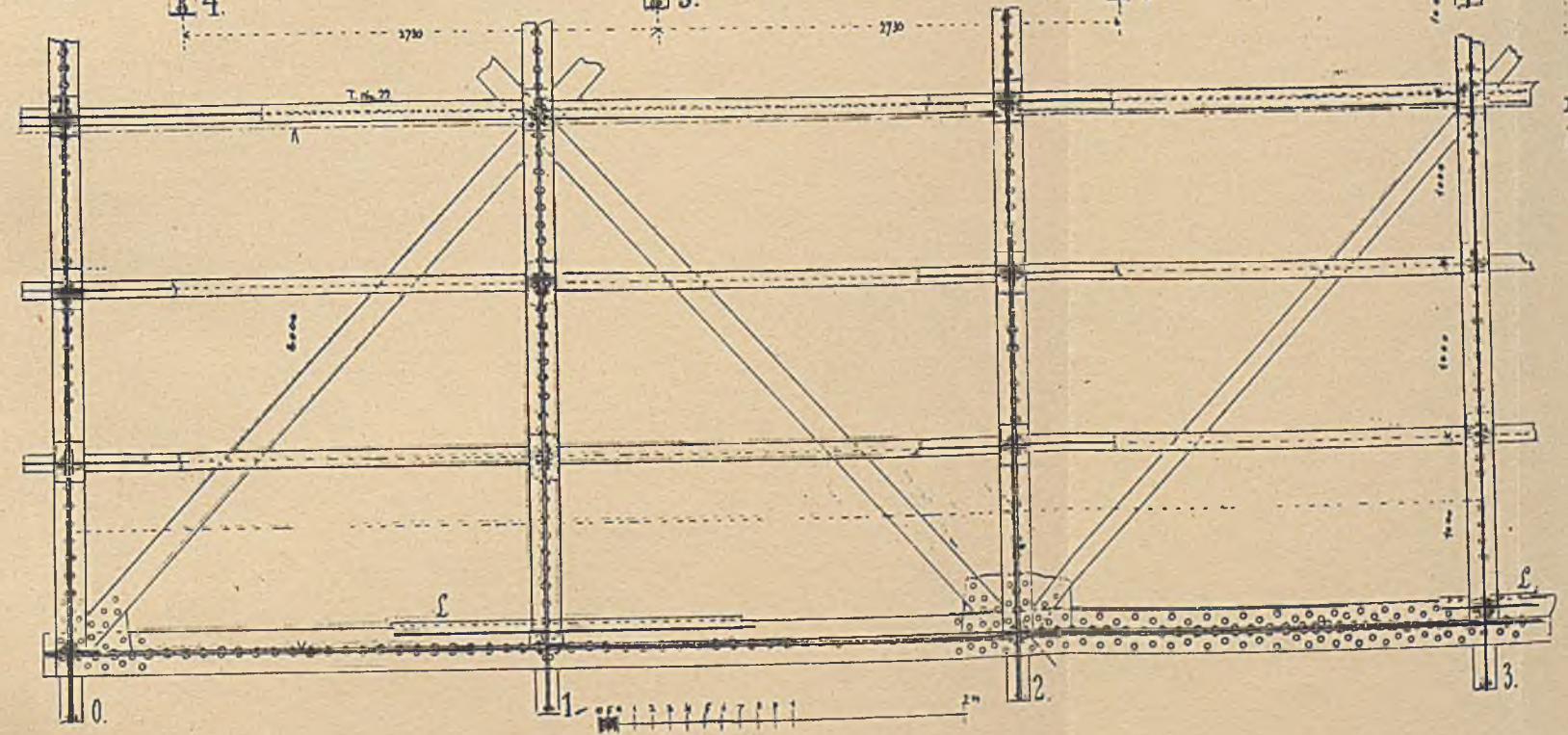
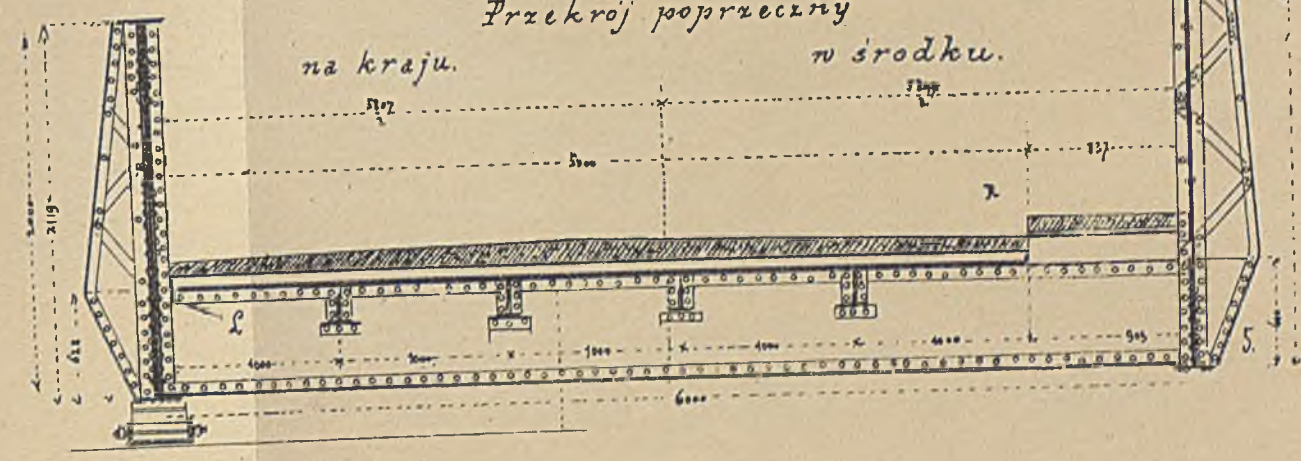

rys. 1.

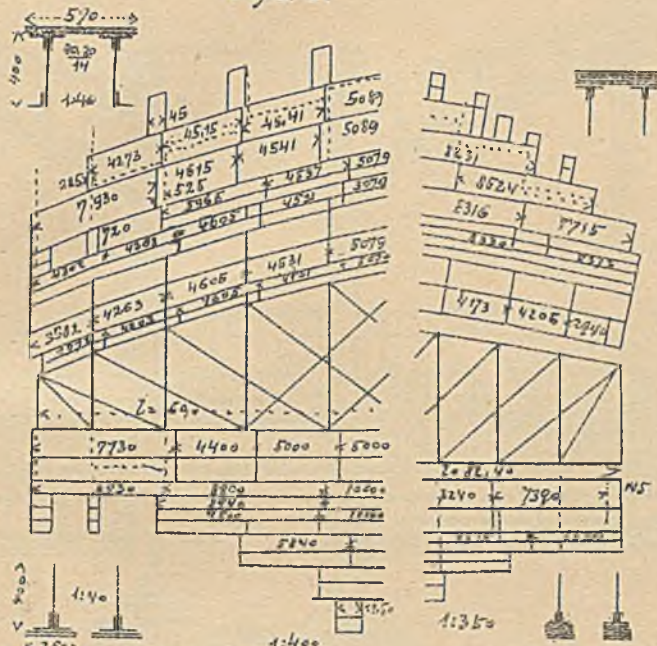

Rozkład materiału mostu na kanale Dunaju w Wiedniu.

Rozkład mat. m. na Wetzlarwie w Budziejowicach.

rys. 2.



Most na Drawie p. Zakany.

rys. 3.

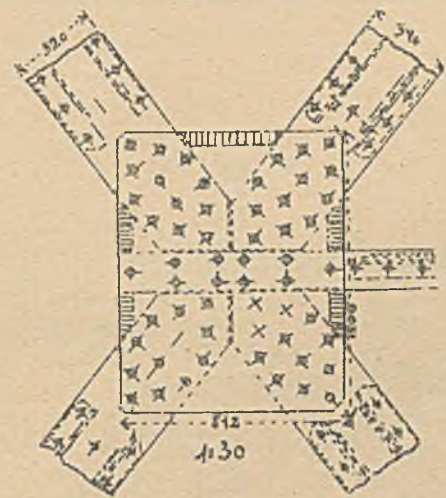

Most na Nogacie w Malborgu.

rys. 4a.

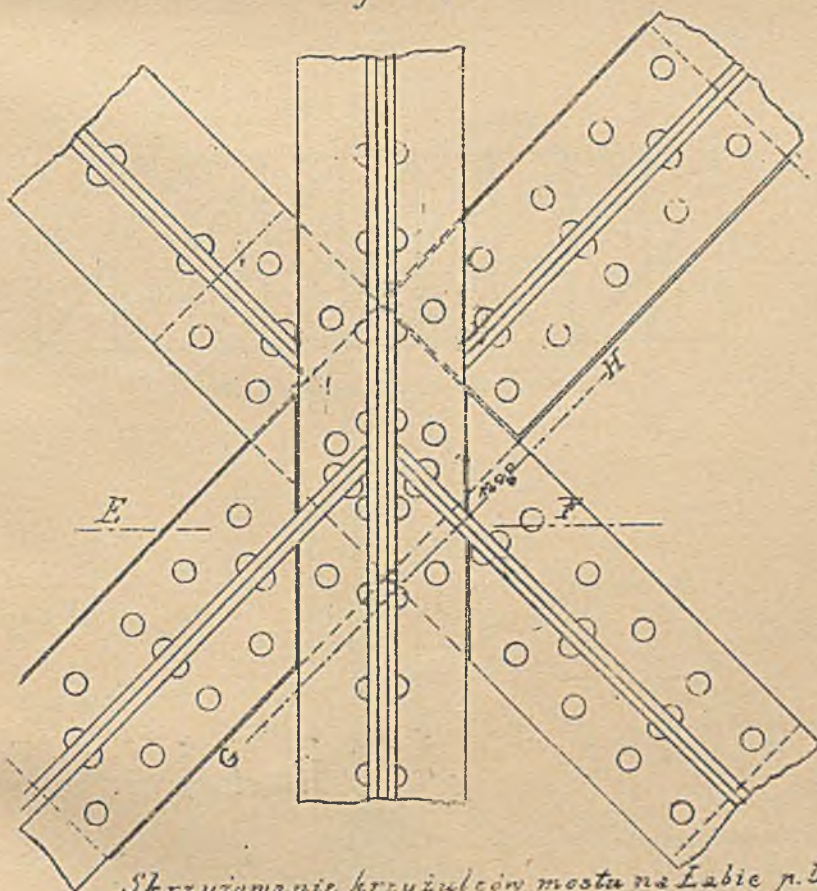

Skrzyżowanie krzywulców mostu na Labie p. Ujściem.

rys. 4b.



Przekrój EE

rys. 4c.

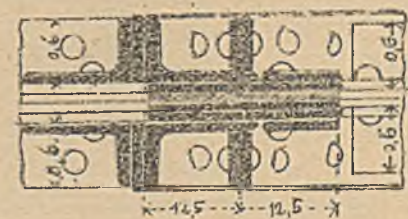

Przekrój GH.

Most na Wiśle pod Toruniem.

rys. 1.

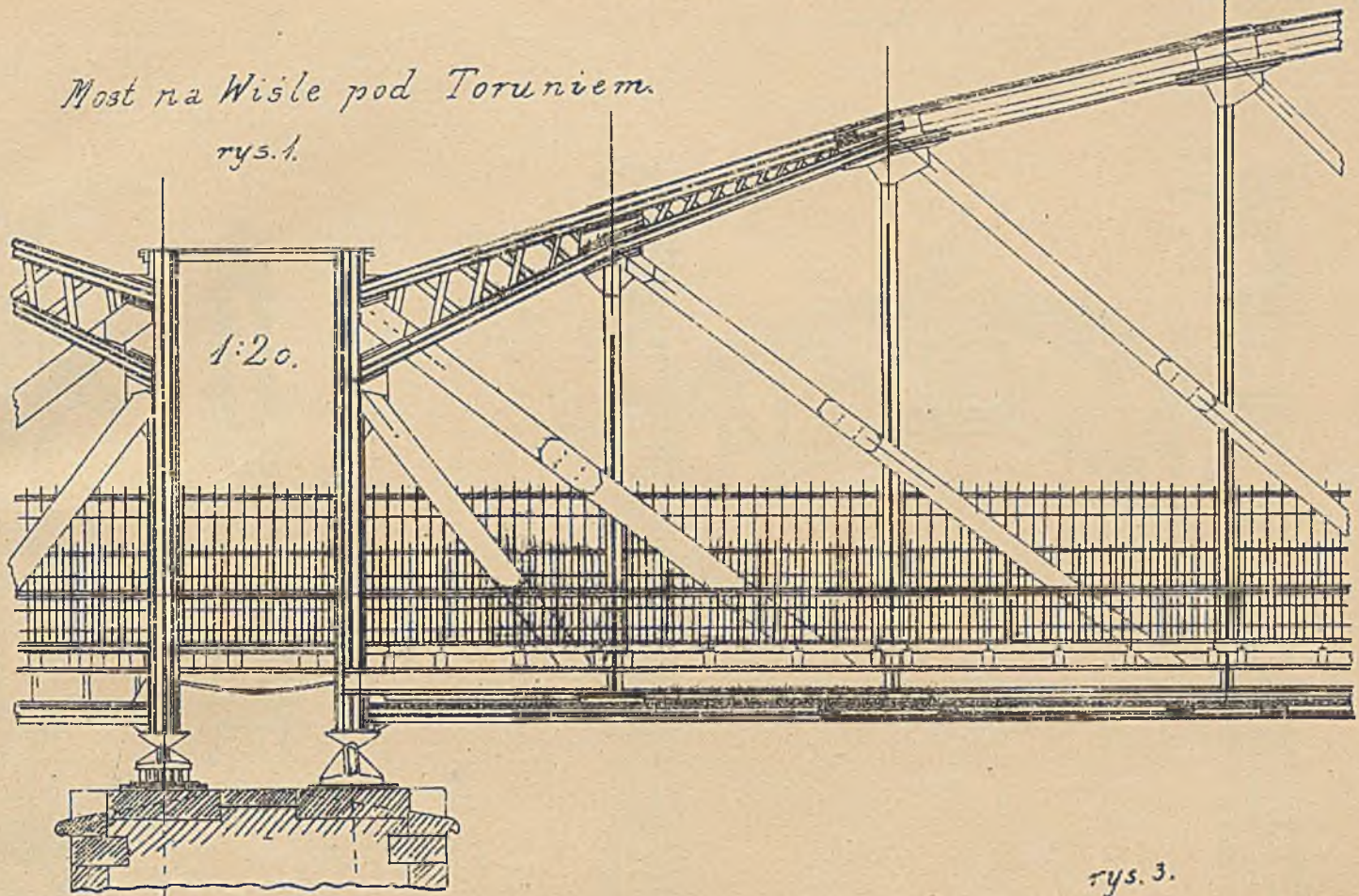

rys. 2.

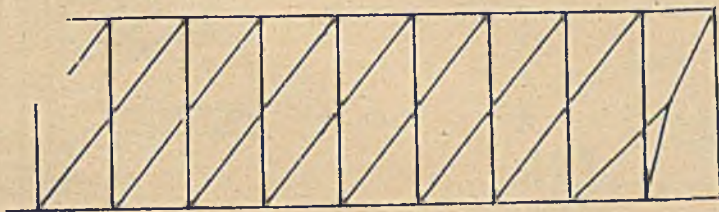

Zakończenie kraty.

rys. 3.

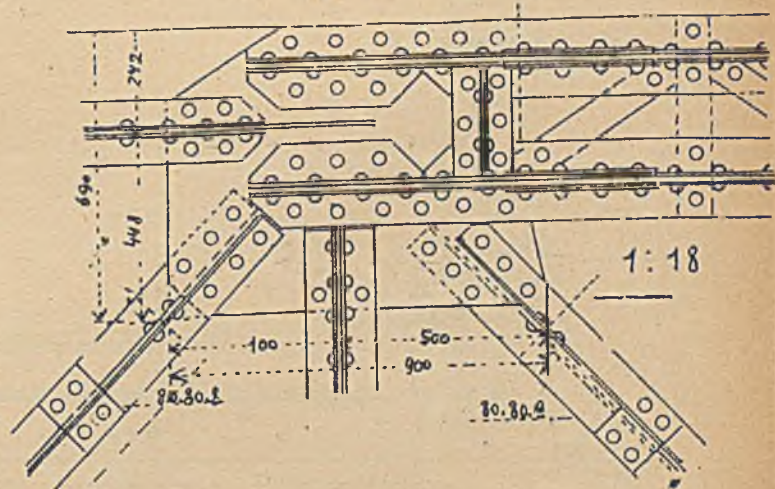

rys. 3a.

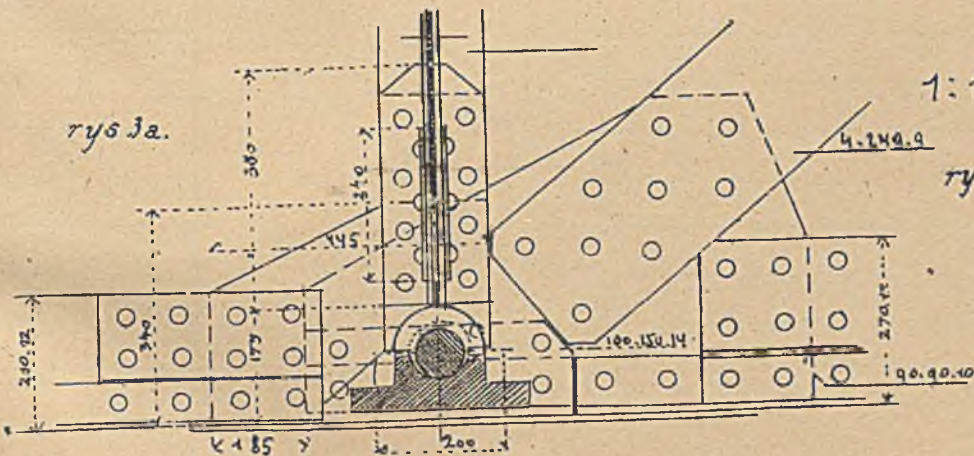

1:12

rys. 3b.

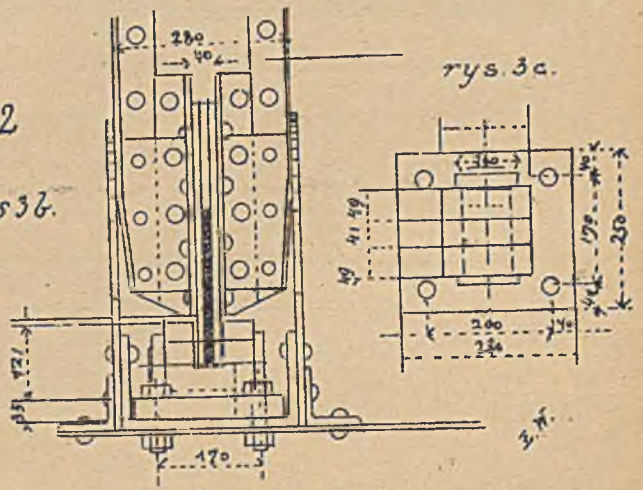

rys. 3c.

Przełaz mostu wspornikowego na Odrze w Stądzieńcu.

Portal nad filarem wiaduktu na Salzachu
między Oberndorf i Laufen.

Tabl 67.

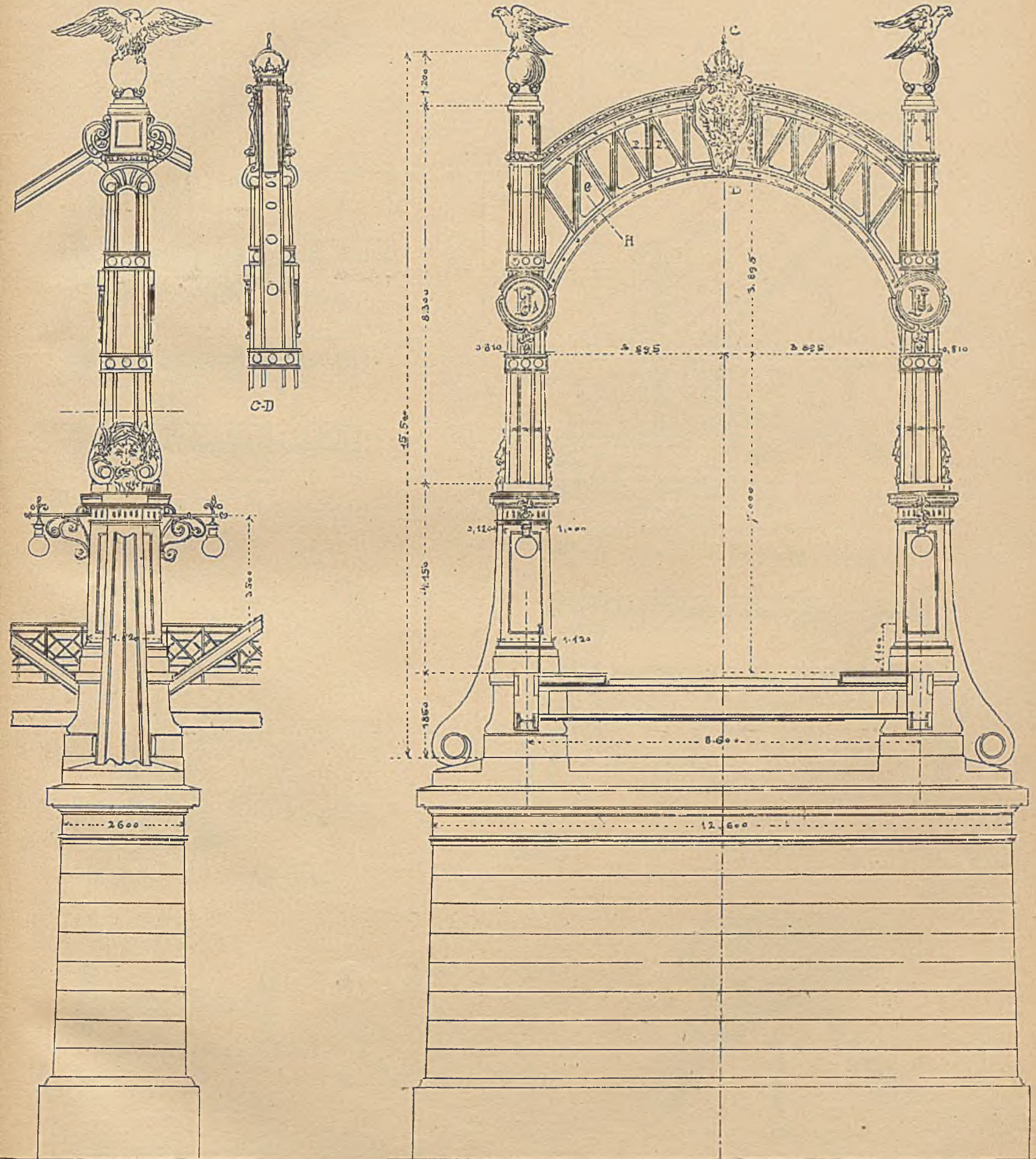

rys. 1.

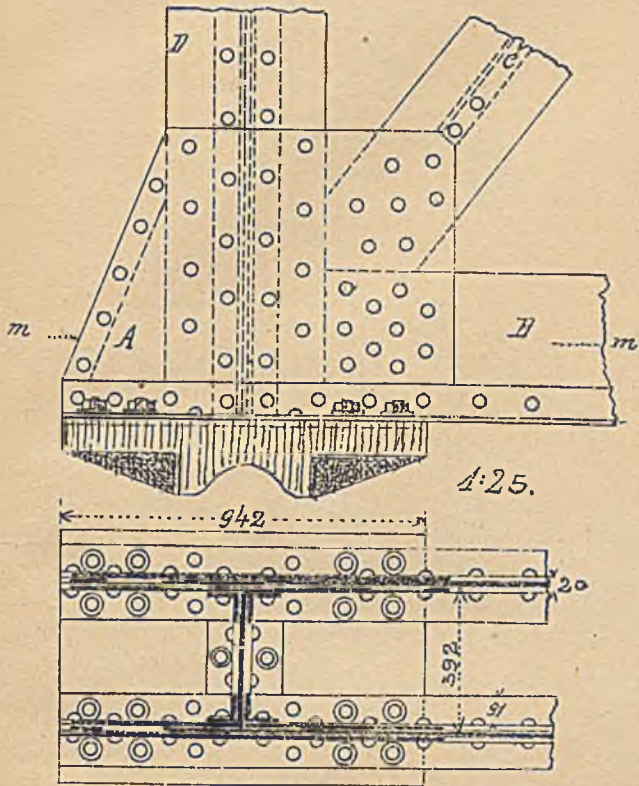

M. na Lahnii p. Lahnstein.

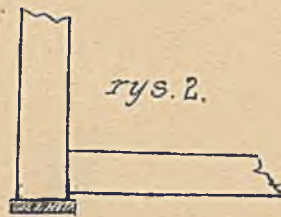

rys. 2.

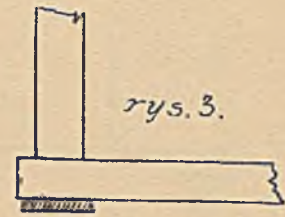

rys. 3.

rys. 4.

1:15.

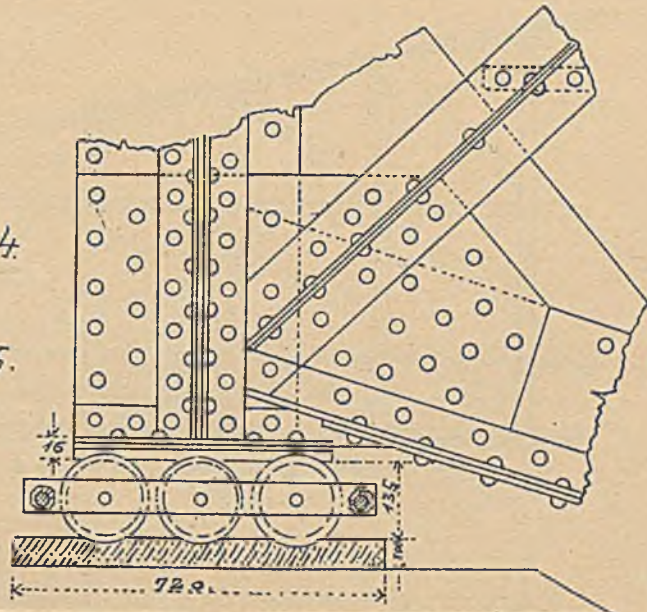

M. na Izerze koto Malej Skaty.

rys. 5.

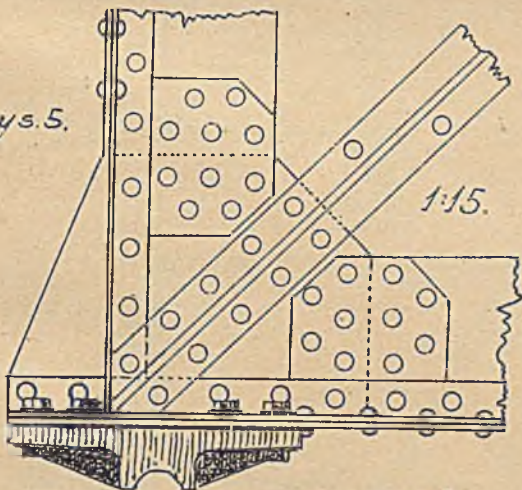

Normalia austr. kolei pot.

rys. 6.

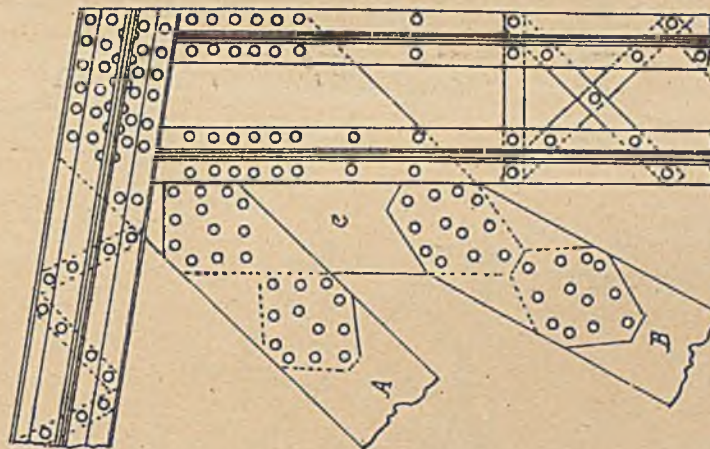

M. na Labie w Miśni. 1:25.

rys. 7.

1:6.



System Schiskorna.

rys. 8.



rys. 9.

1:20.

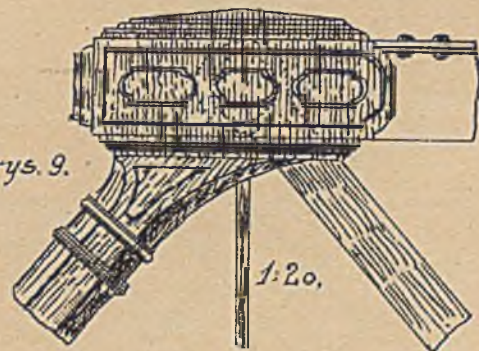

System Warren a.

rys. 1.

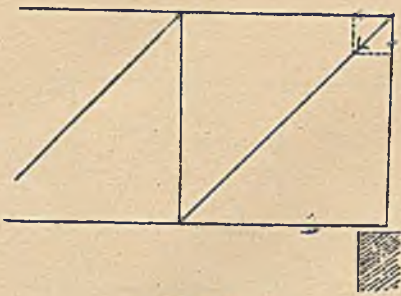

rys. 2.

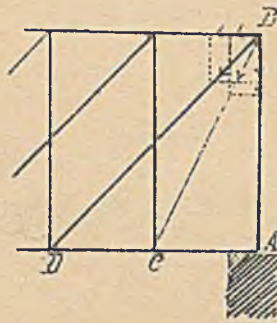

rys. 3.

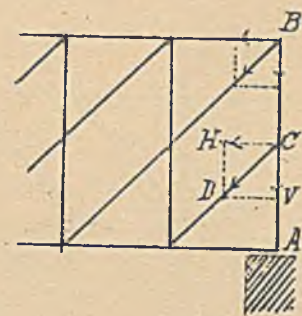

rys. 4.

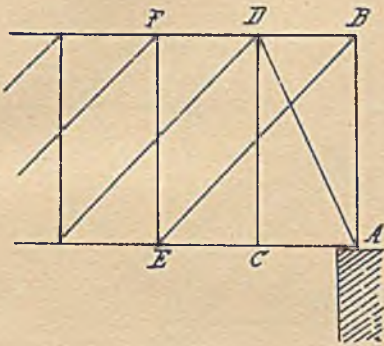

rys. 5.

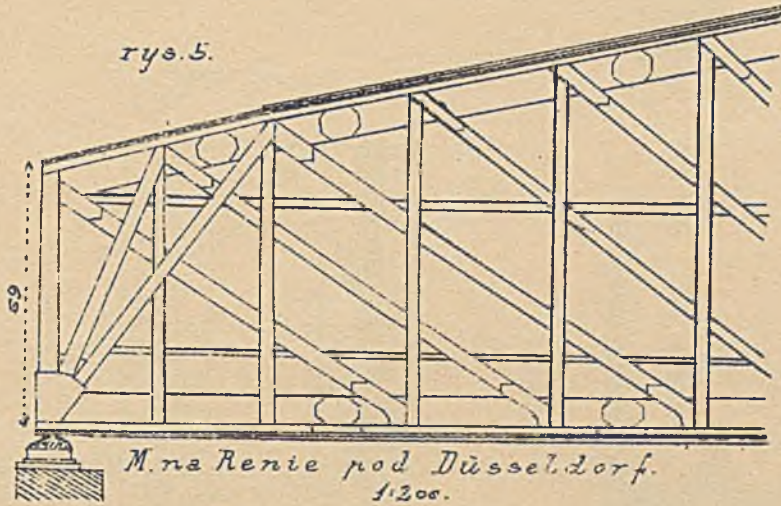

rys. 6.

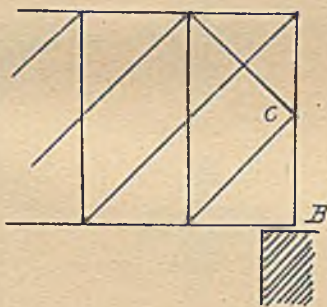

rys. 7.

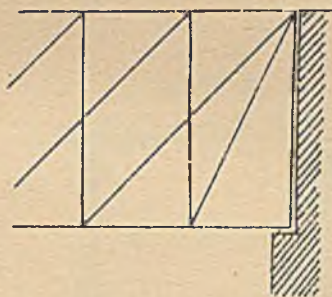

rys. 8.

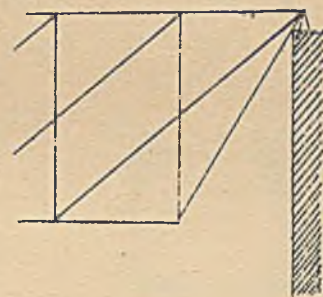

rys. 9.

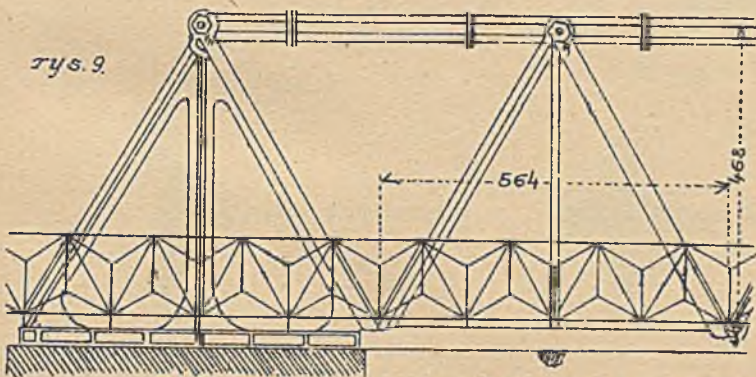

Most na Trencie pod Newark. 1:820.

rys. 10.

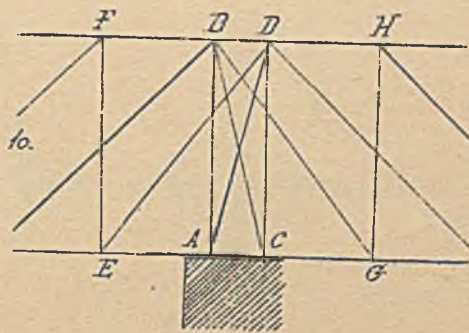

rys. 11.

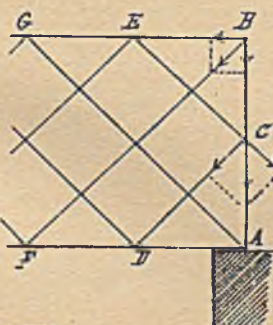

rys. 12.

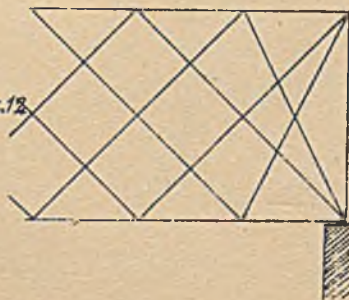

rys. 13.



Handwritten mark or signature.

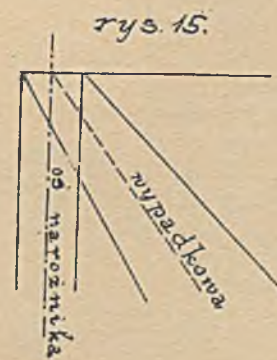
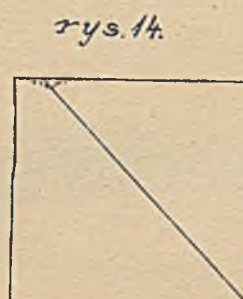
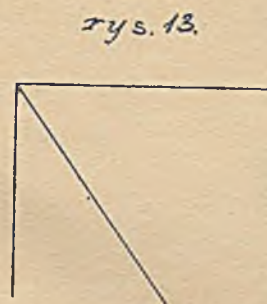
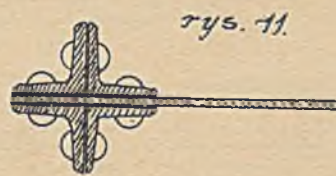
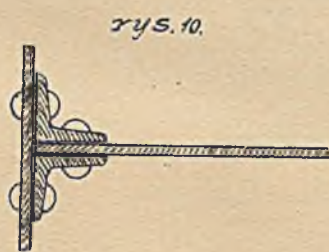
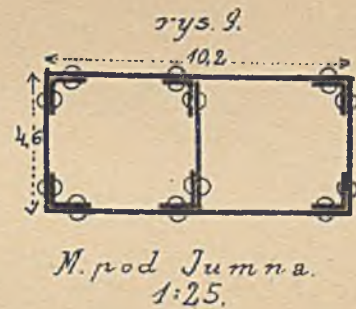
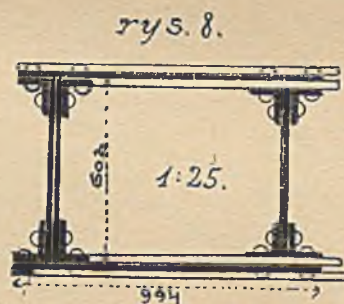
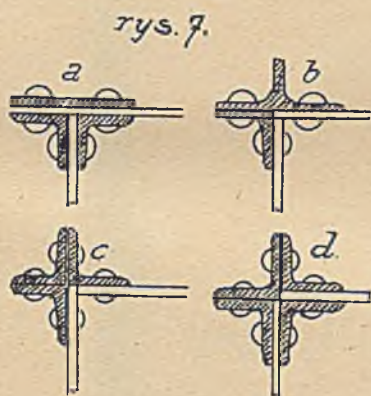
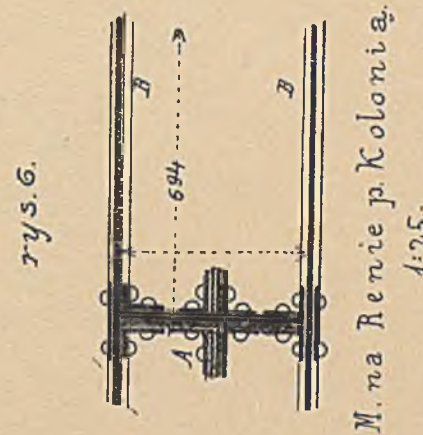
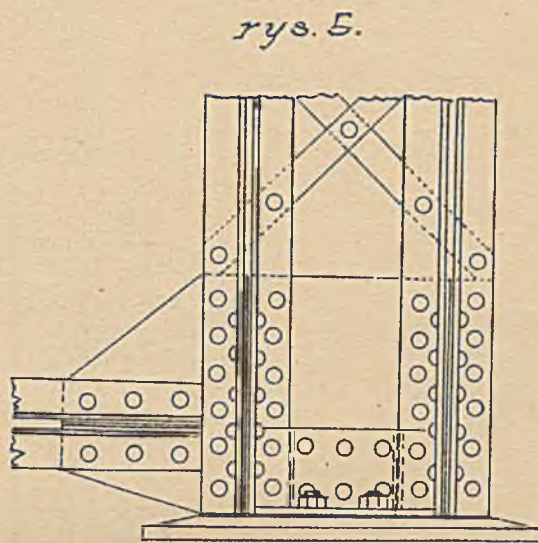
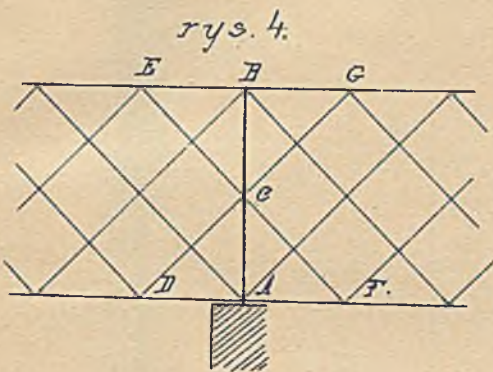
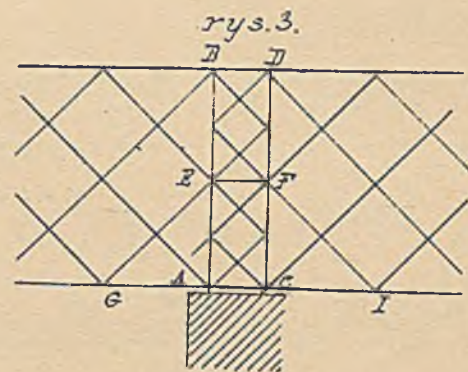
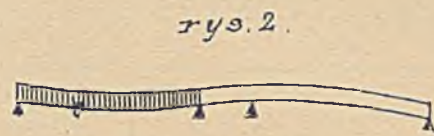
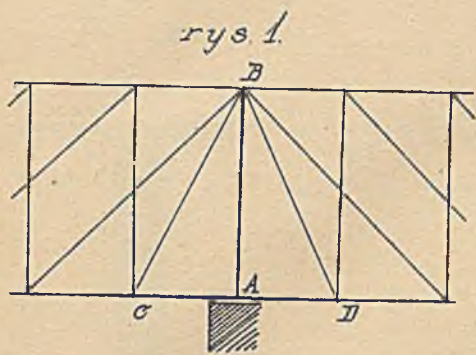

Narozniki.

Most na kverze koto Turnau.

Tabl. 71

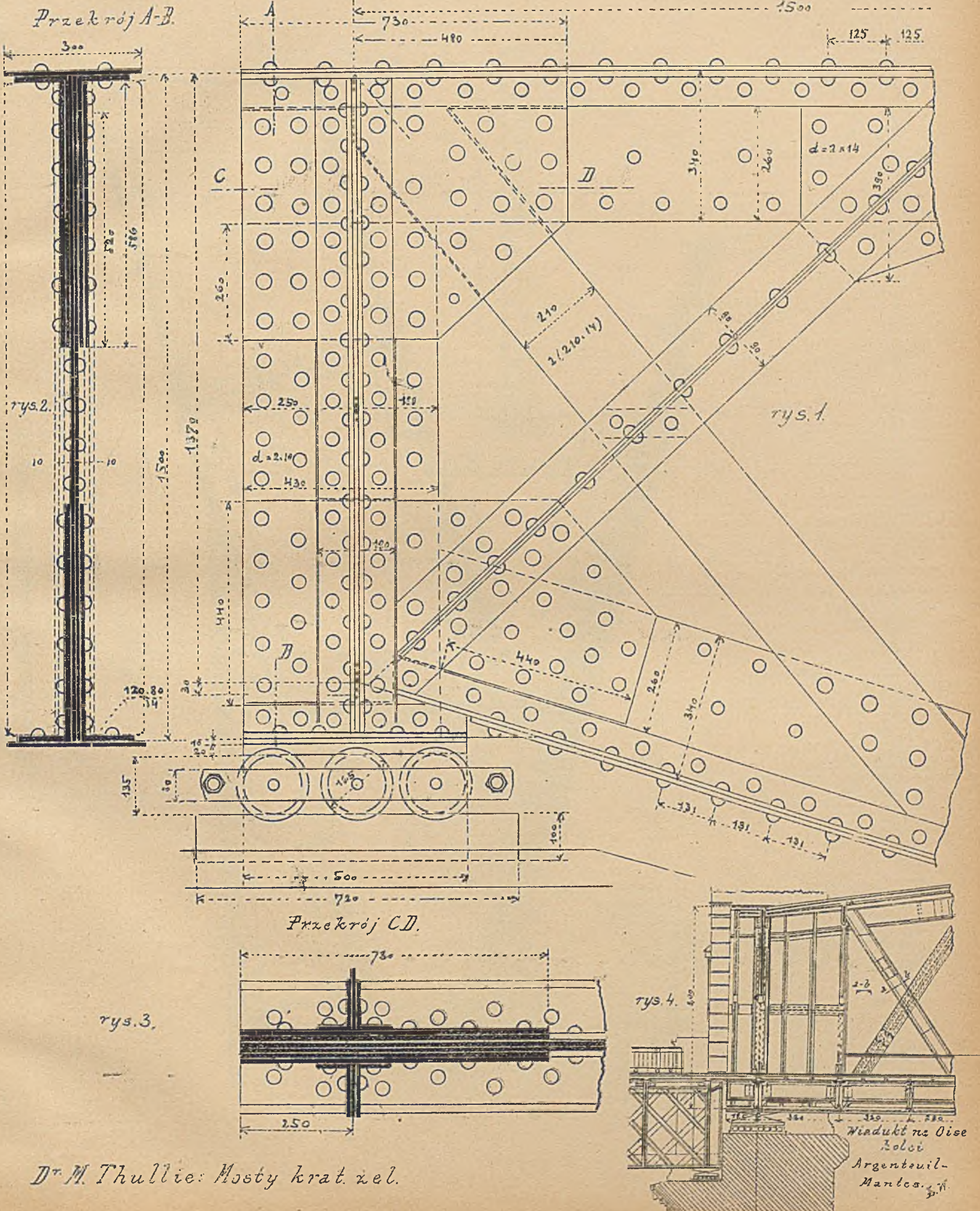

Zakoniecenie belek rzeiowych.

Most na Renie w Moguncyi.

Rys. 1.

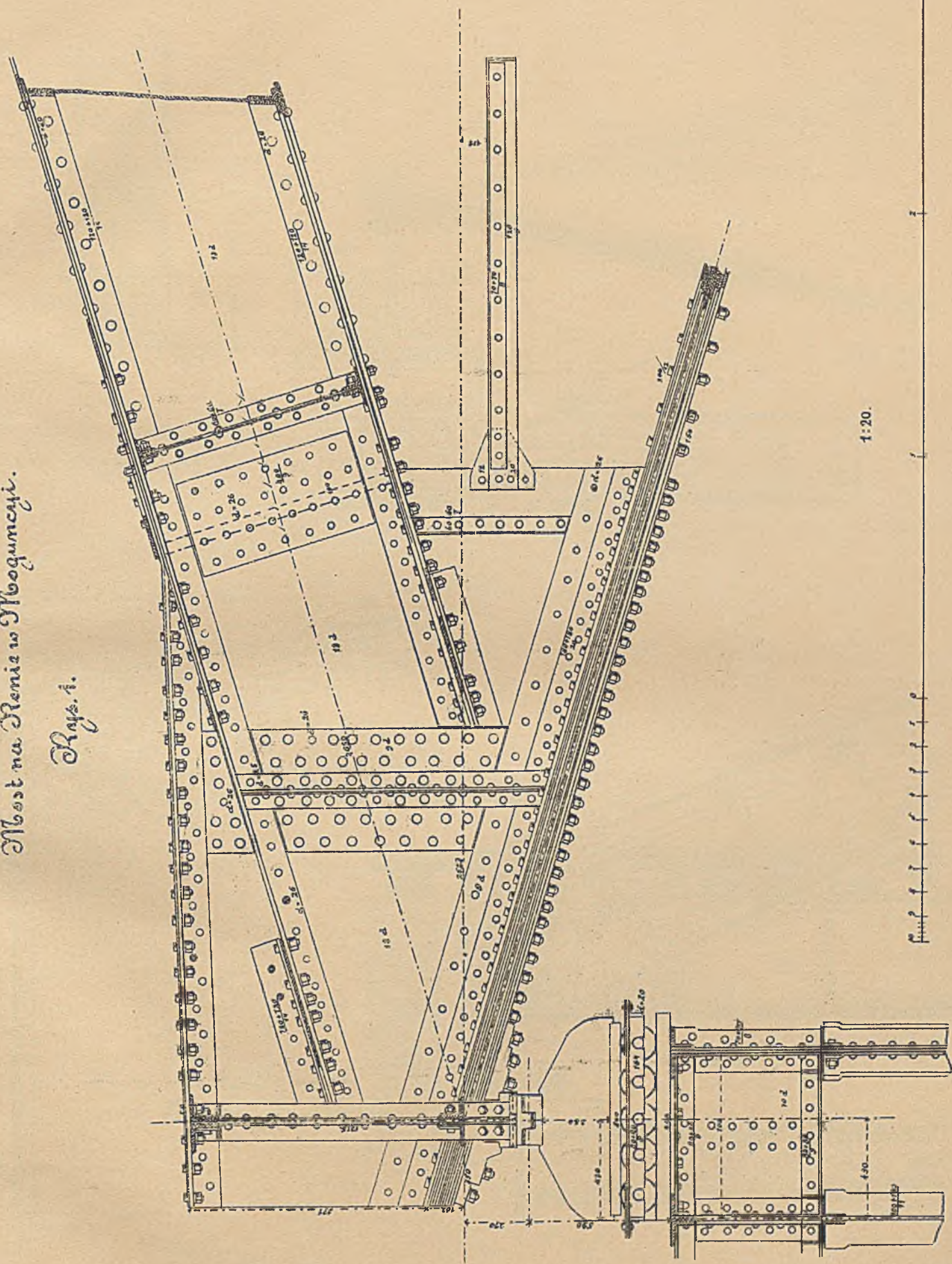

1:20.



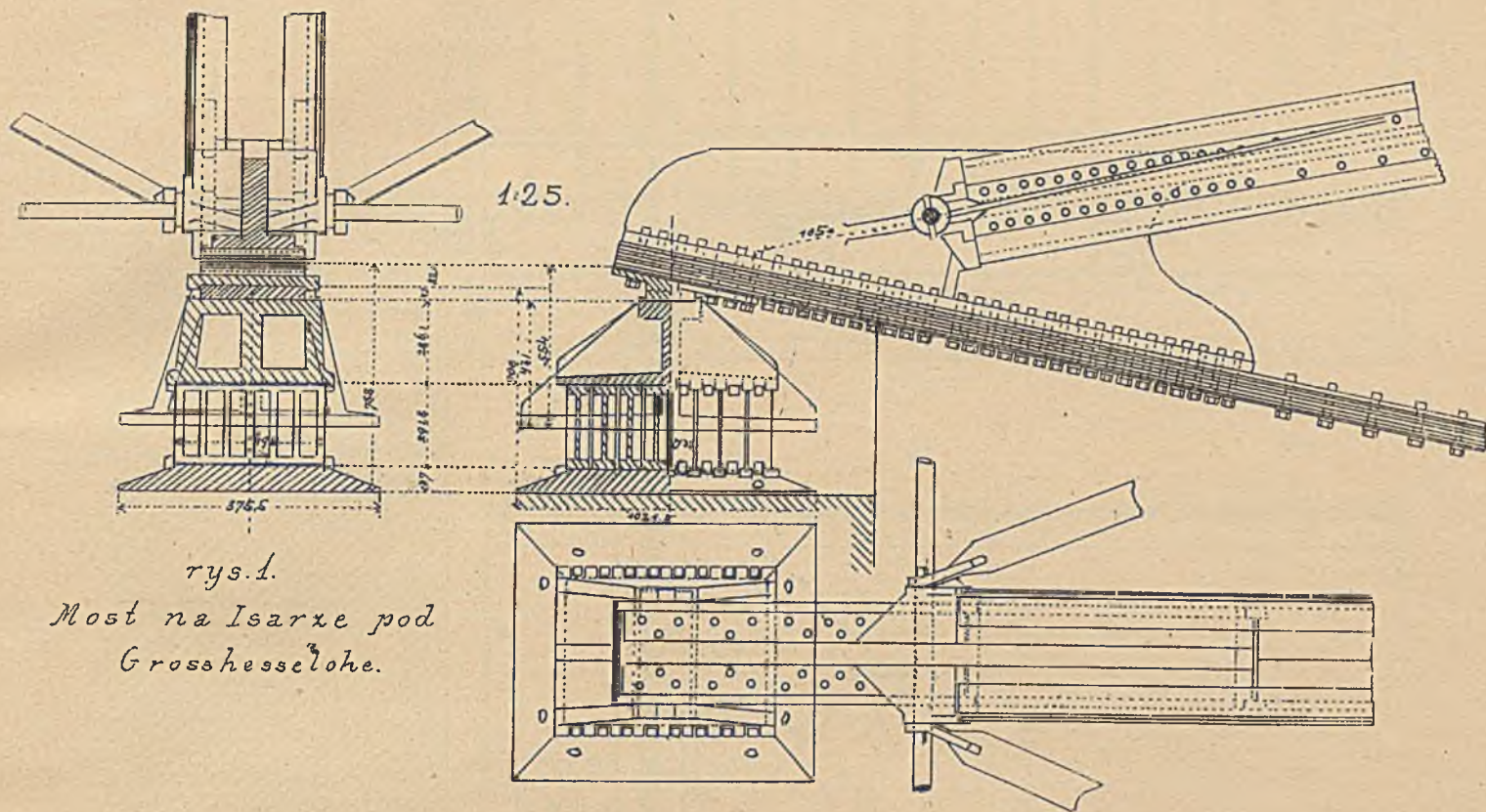

rys. 1.
Most na Isarze pod
Grosshesselohe.

Górny węzeł narożnika.

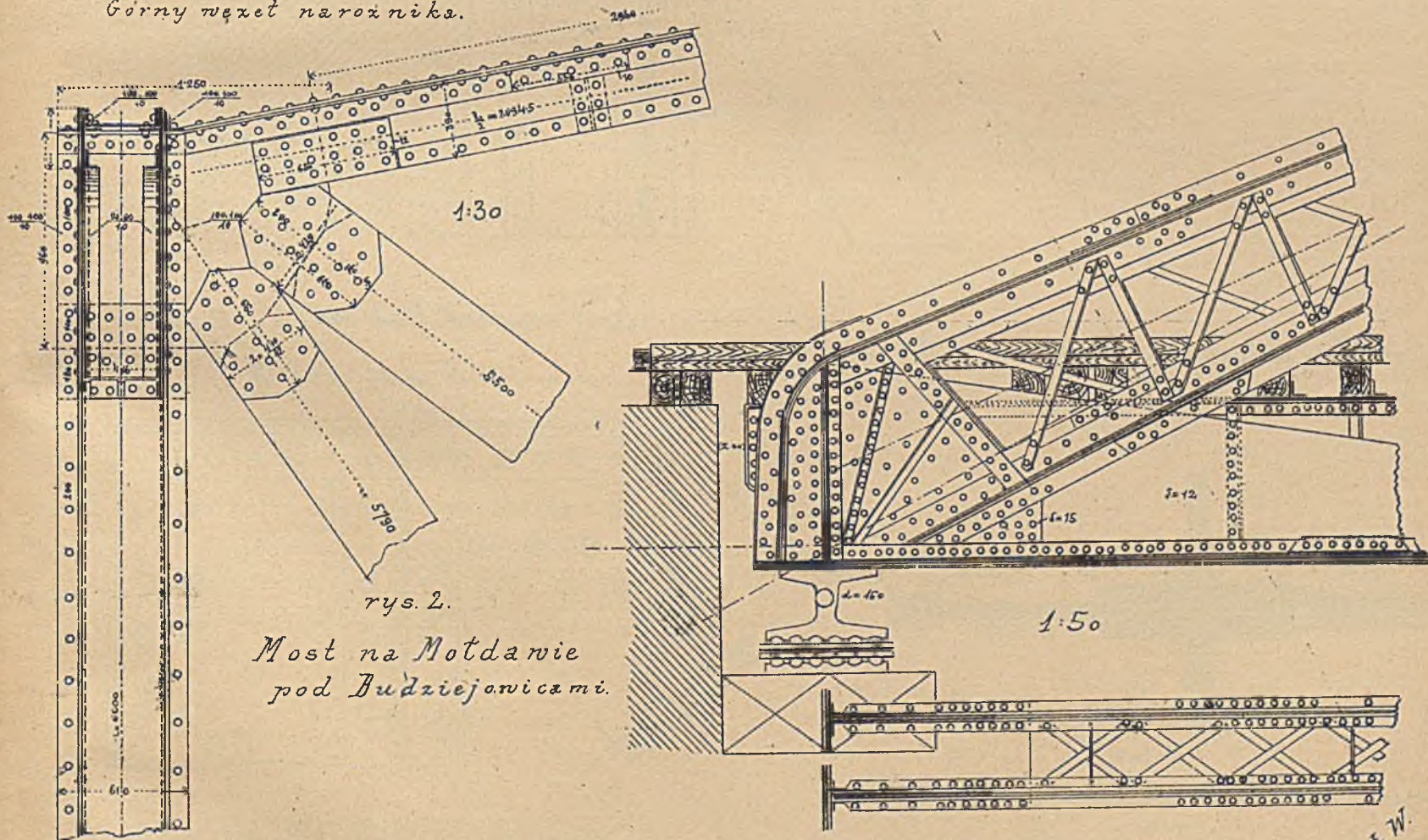

rys. 2.
Most na Motdawie
pod Budziejowicami.

rys. 3.

Most na Dnieprze pod Rzeczycą.

Wzrost górny naroznika.

Most na Dniestrze w Zakleszyniekach.
Rys. 1.

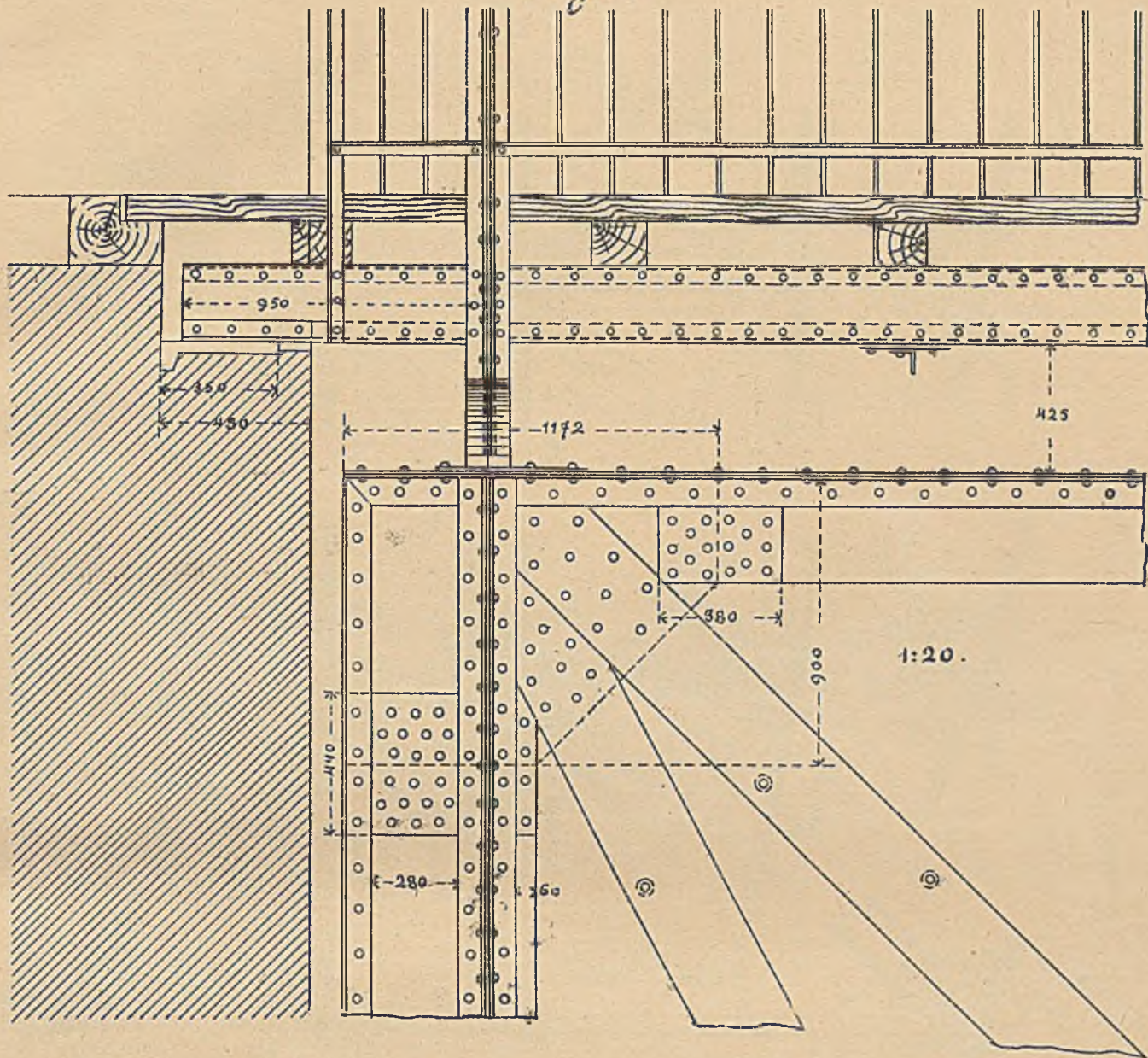

Rys. 2. Most nad Dworcem kolei
Głubickiej w Wiedniu.
1:10

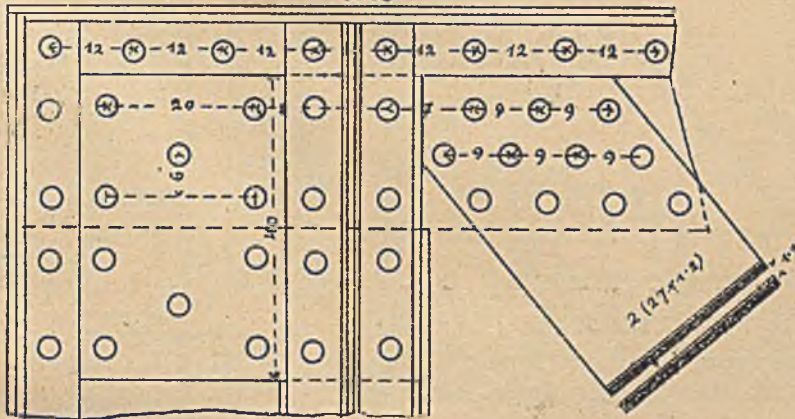

Rys. 2 a. Przekrój poprzeczny.

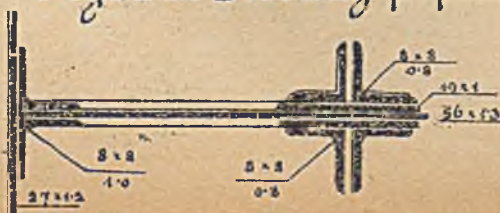

Rys. 3. Most w Uściu na Łabie.
1:10

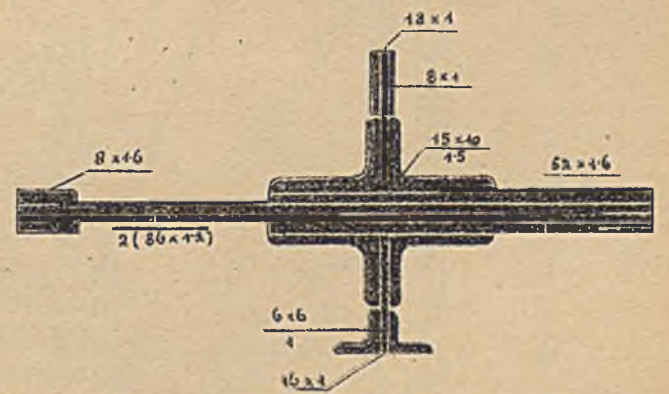

Rys. 4. Most na Haveli pod Rathenowem.
1:40

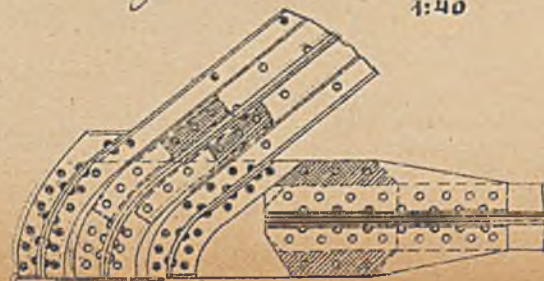

10.

Most kolei arulnickiej na Ižice.

Przekrój m-11

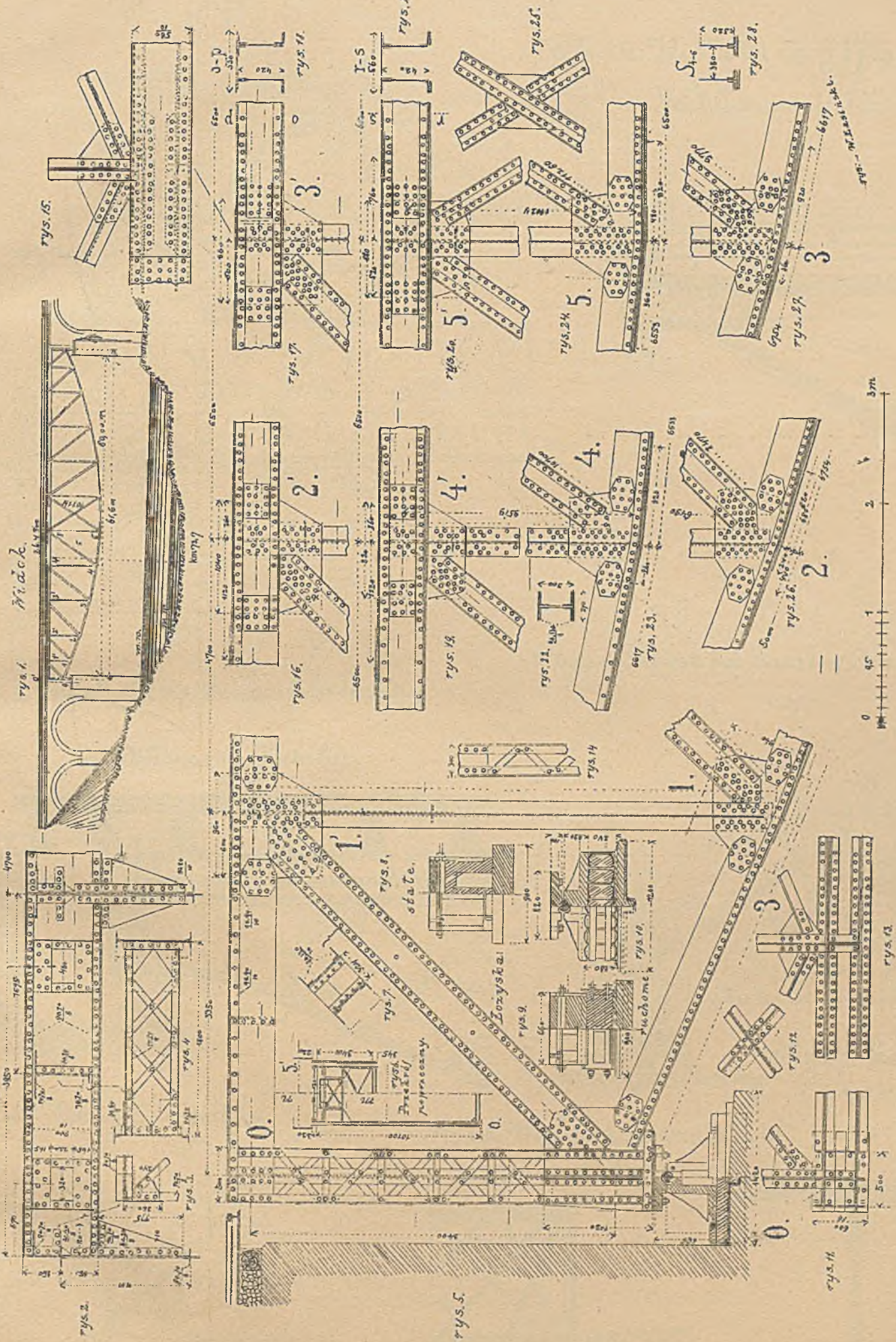

Dr. M. Thullie: Mosty kratowe zelazne.

Narożniki.

Tabl. 77.

rys. 1.

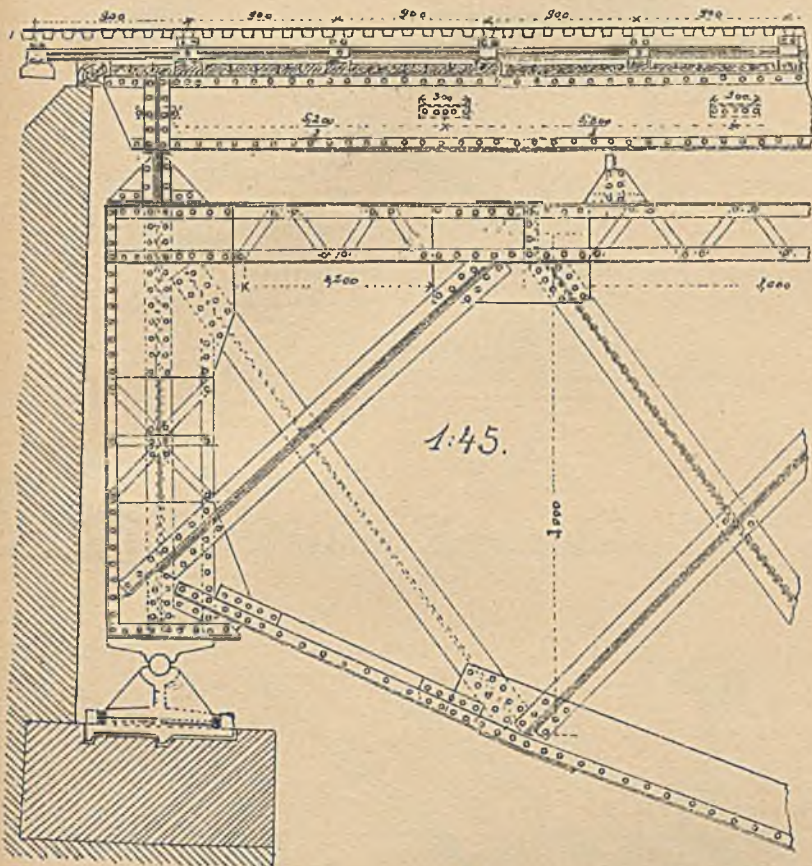

M. nad jarem Luca w Bośni.

rys. 2.



M. na Dunaju koto Mautern.

rys. 3.



M. na Ochrzy w Żatcu

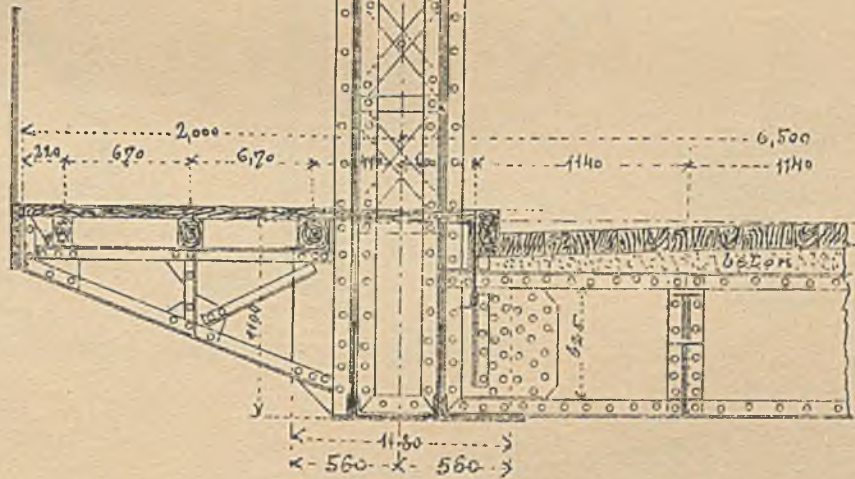

rys. 4.

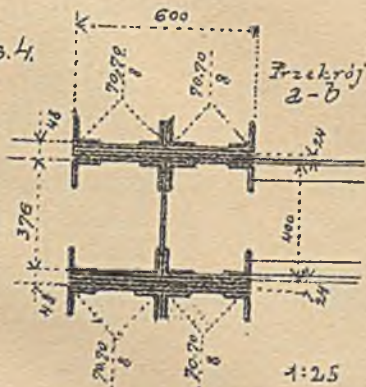

Wiadukt Karako na Węgrzech.

rys. 5.



rys. 7.

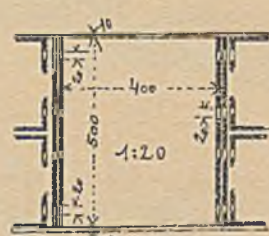

M. miejskiej k. wiedeń.

rys. 8.

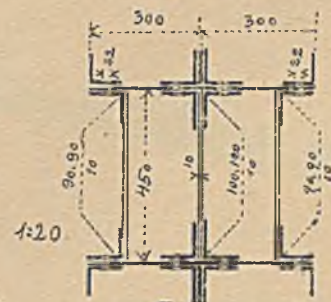

M. na Dunaju k. Mautern.

Rys. 1. Most na Muldrze pod Eilenburgiem.

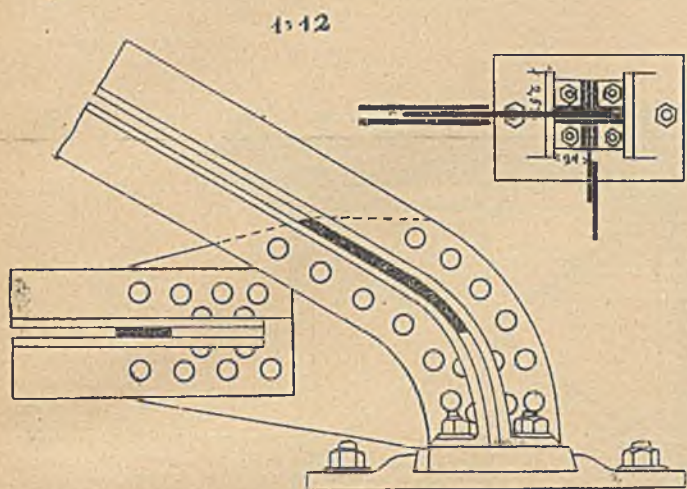

Rys. 2. Most Les. Józefa na kanale Dunaju w Wiedniu.

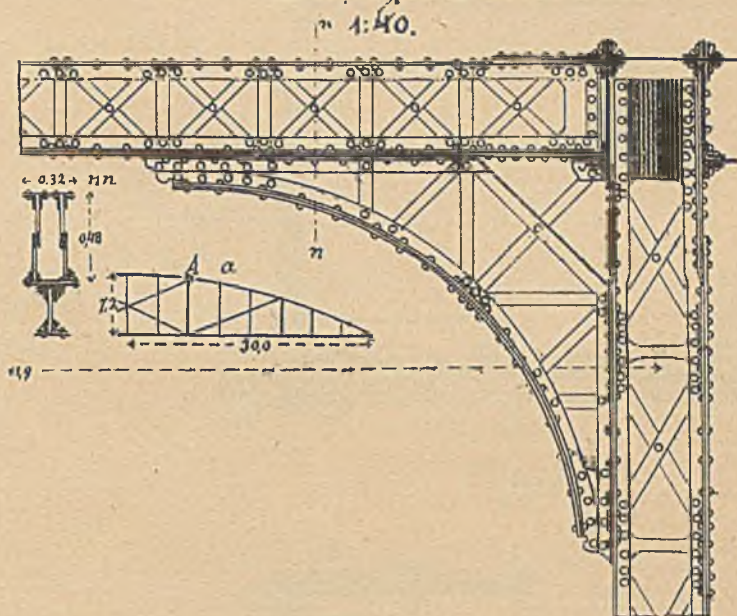

Rys. 3. Belka Schwedlera

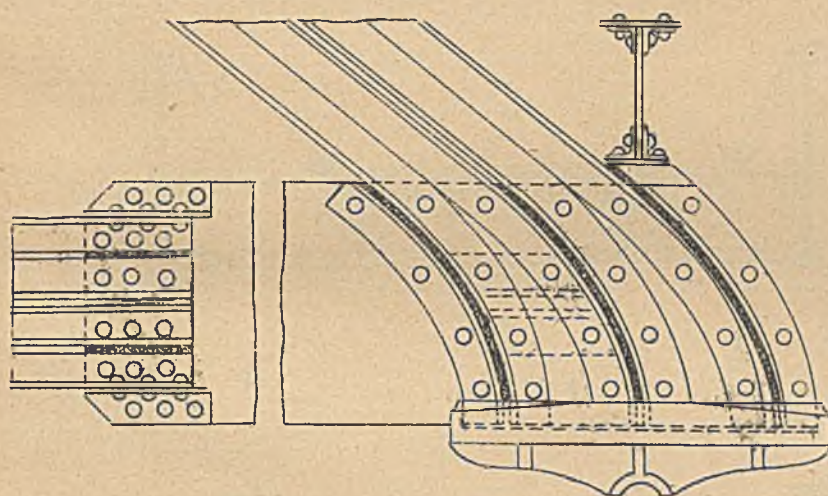

Rys. 4 a. b. Przejazd nad dworcem w Erfurcie

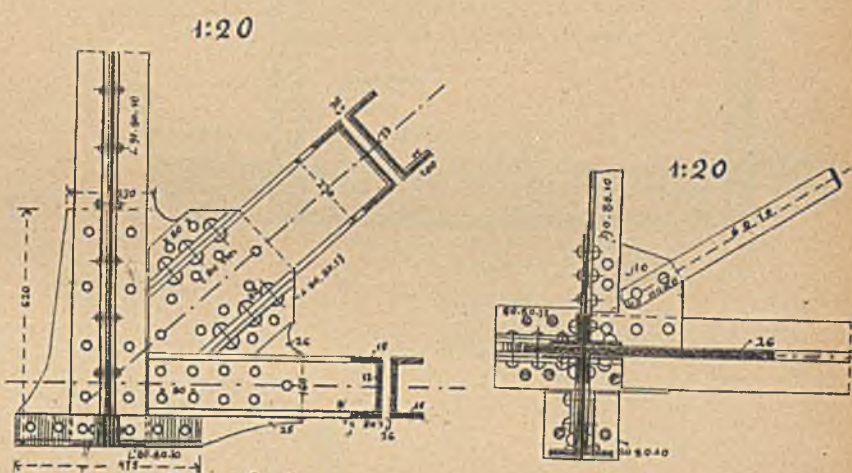

Rys. 5. Most na Dravie pod Grossheselake.

1:25

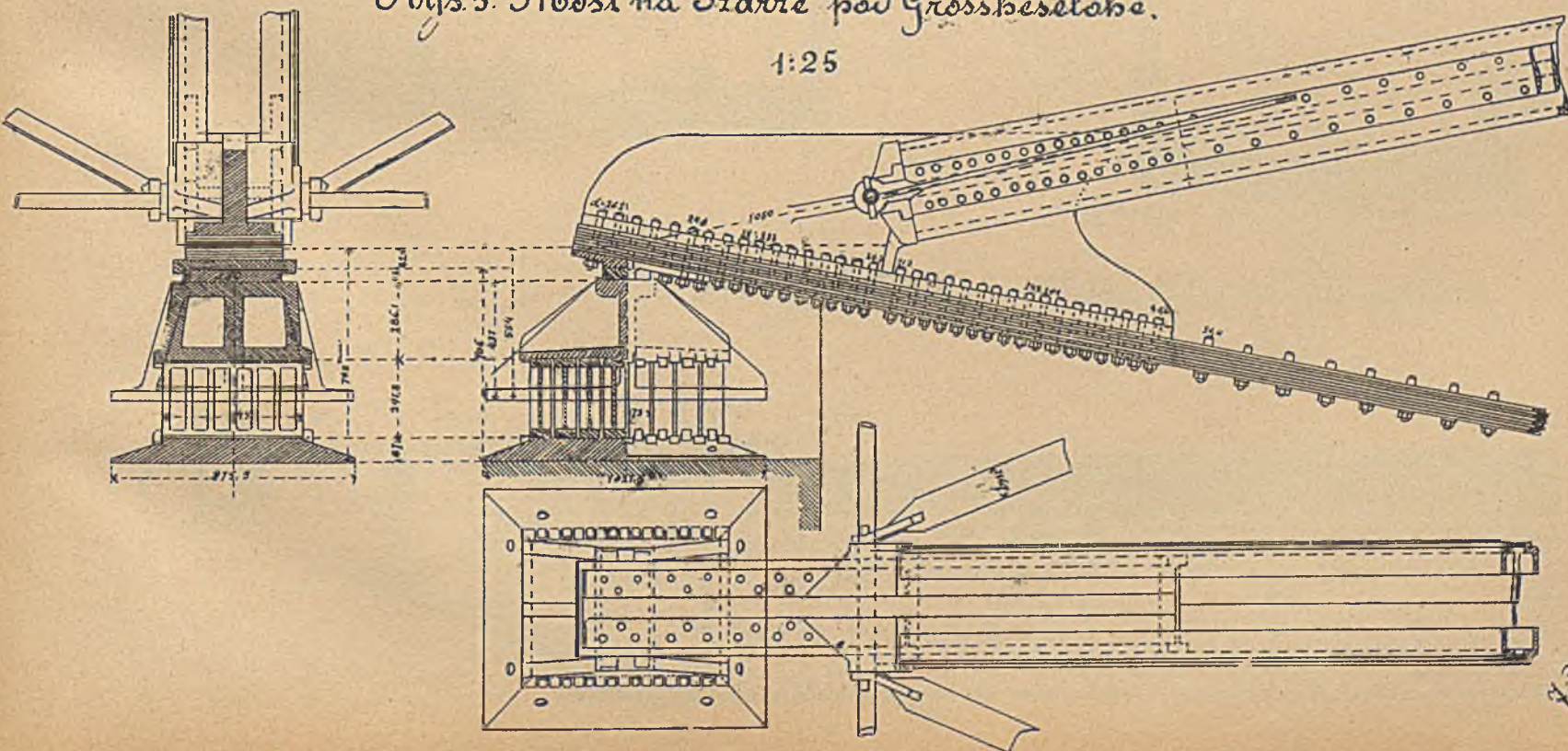

Przekroje poprzeczne mostów.

Rys. 1a. Mosty amerykańskie.

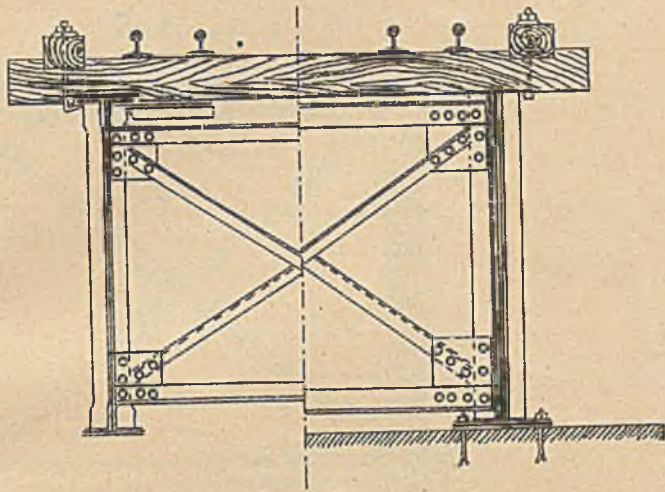

Rys. 1b.

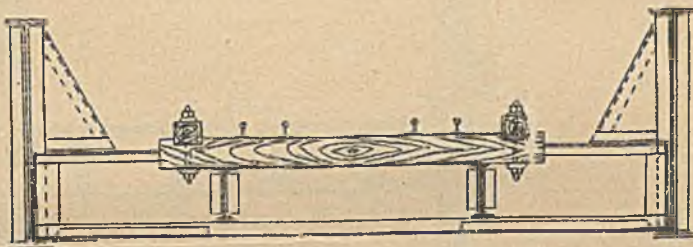

Rys. 1c.

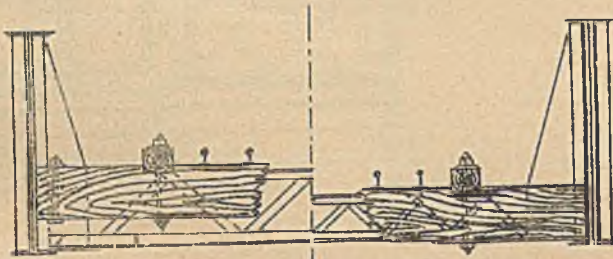

Rys. 2a. Mosty drogowe na kanale
Dortmund-Emm.

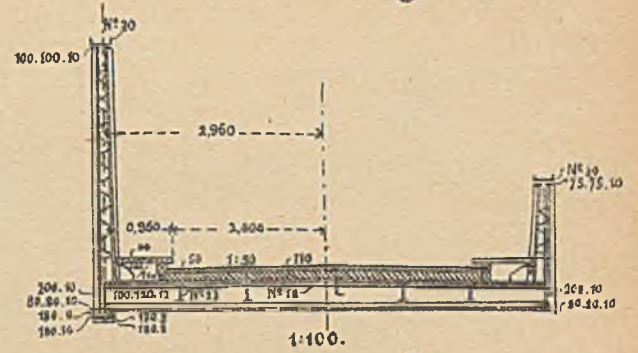

Rys. 2b.

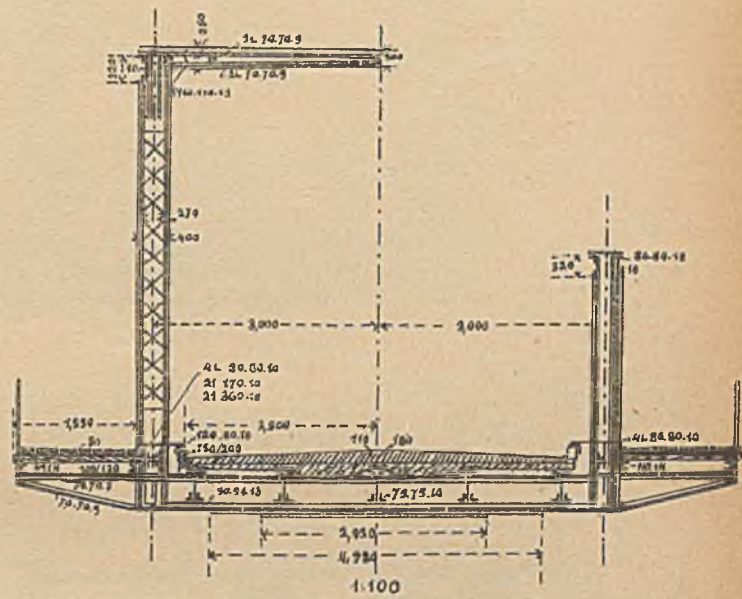

Rys. 2c.

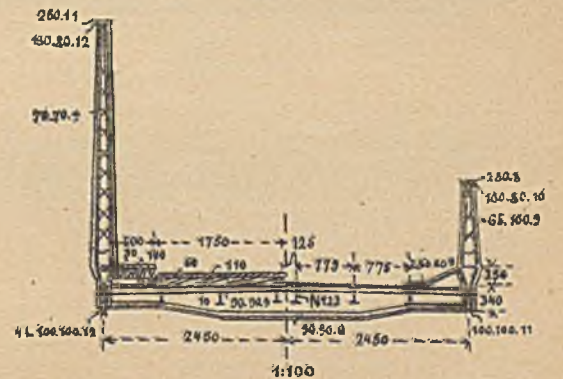

Rys. 3. Most na Dunaju między Stein i Mautern.

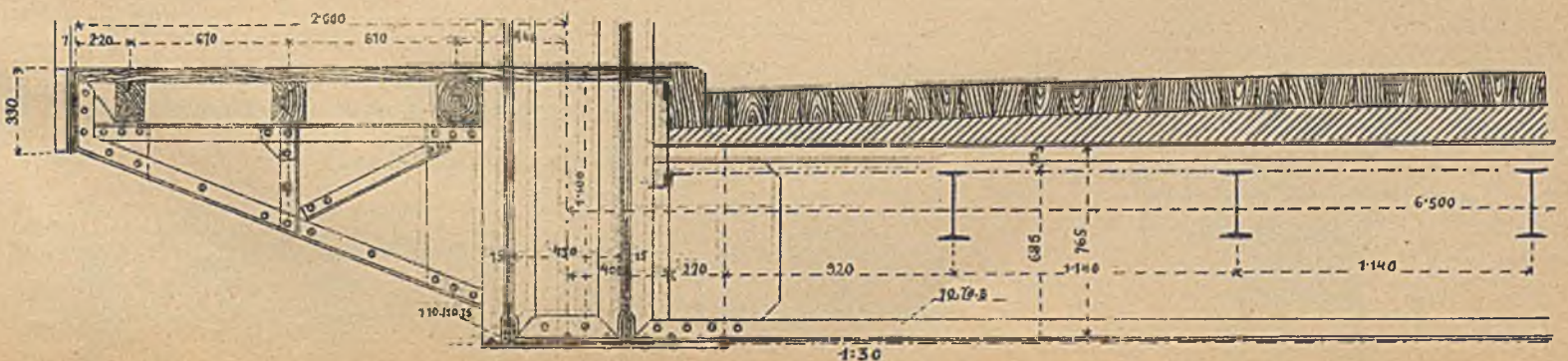

Przekroje poprzeczne mostów.

Rys. 1. Most na Mississippii w New Rock Island.

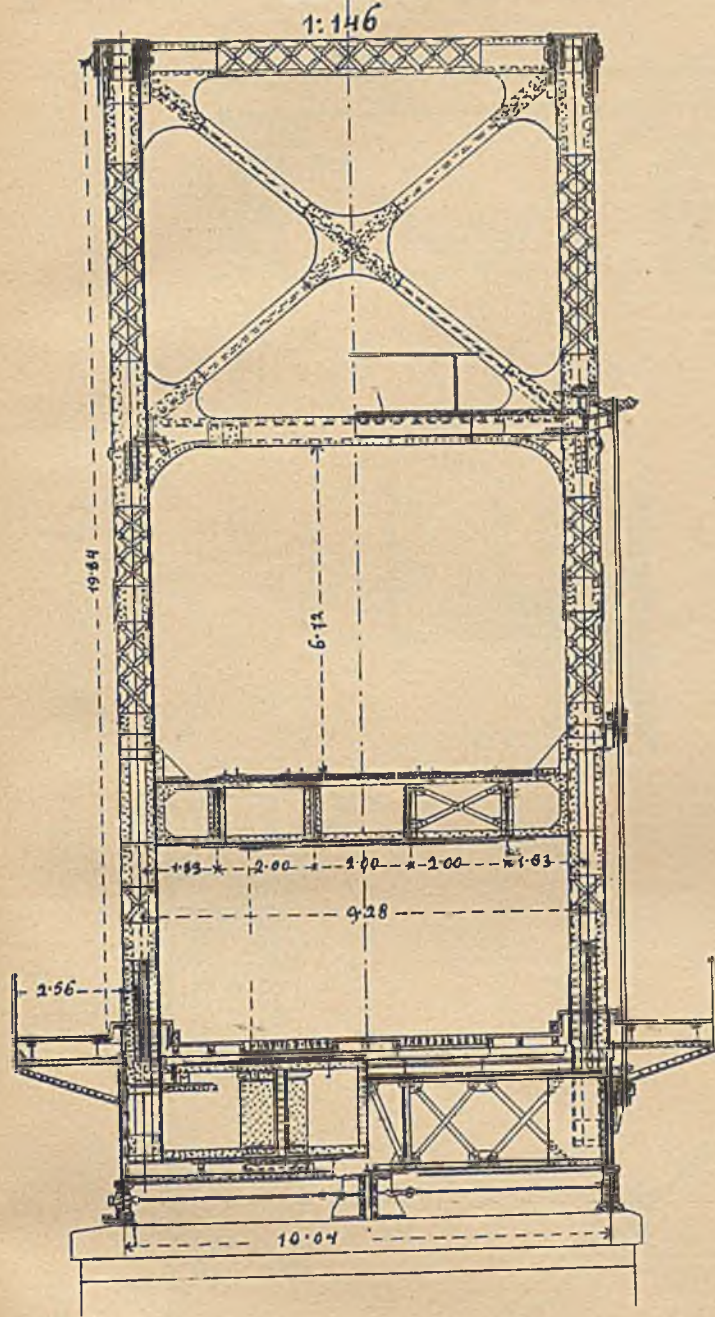

Rys. 2 d.

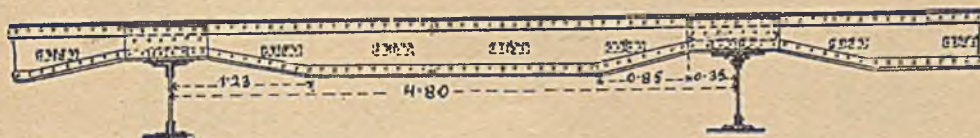

Rys. 3. Most drogowy na Dunaju między Stein i Wautern. Sodkwinice skrajne.



Rys. 2a. Most na Kistnie w Indyach.

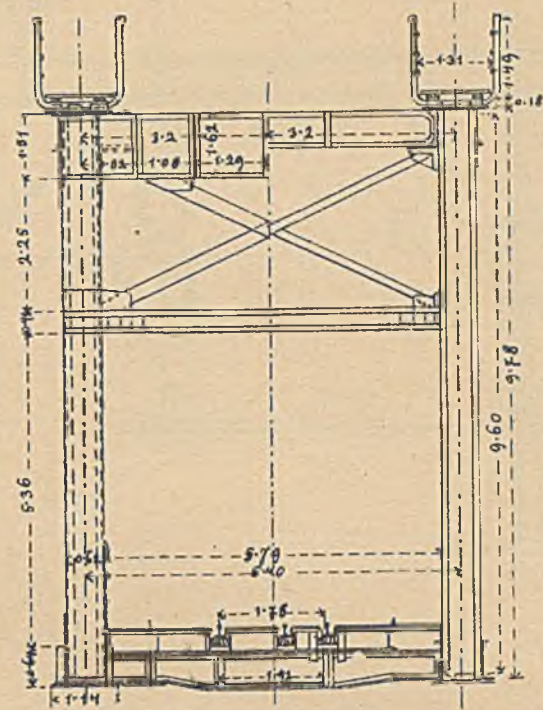

Rys. 2 b.

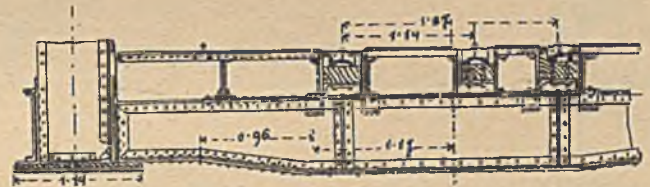

Rys. 2 c.

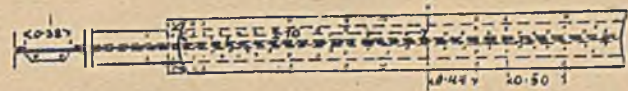

Rys. 2 e.



Rys. 2 f.

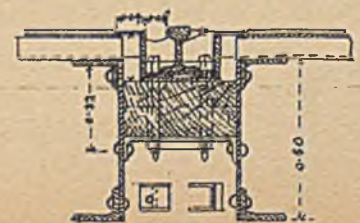

Narożniki.

Tabl. 81.

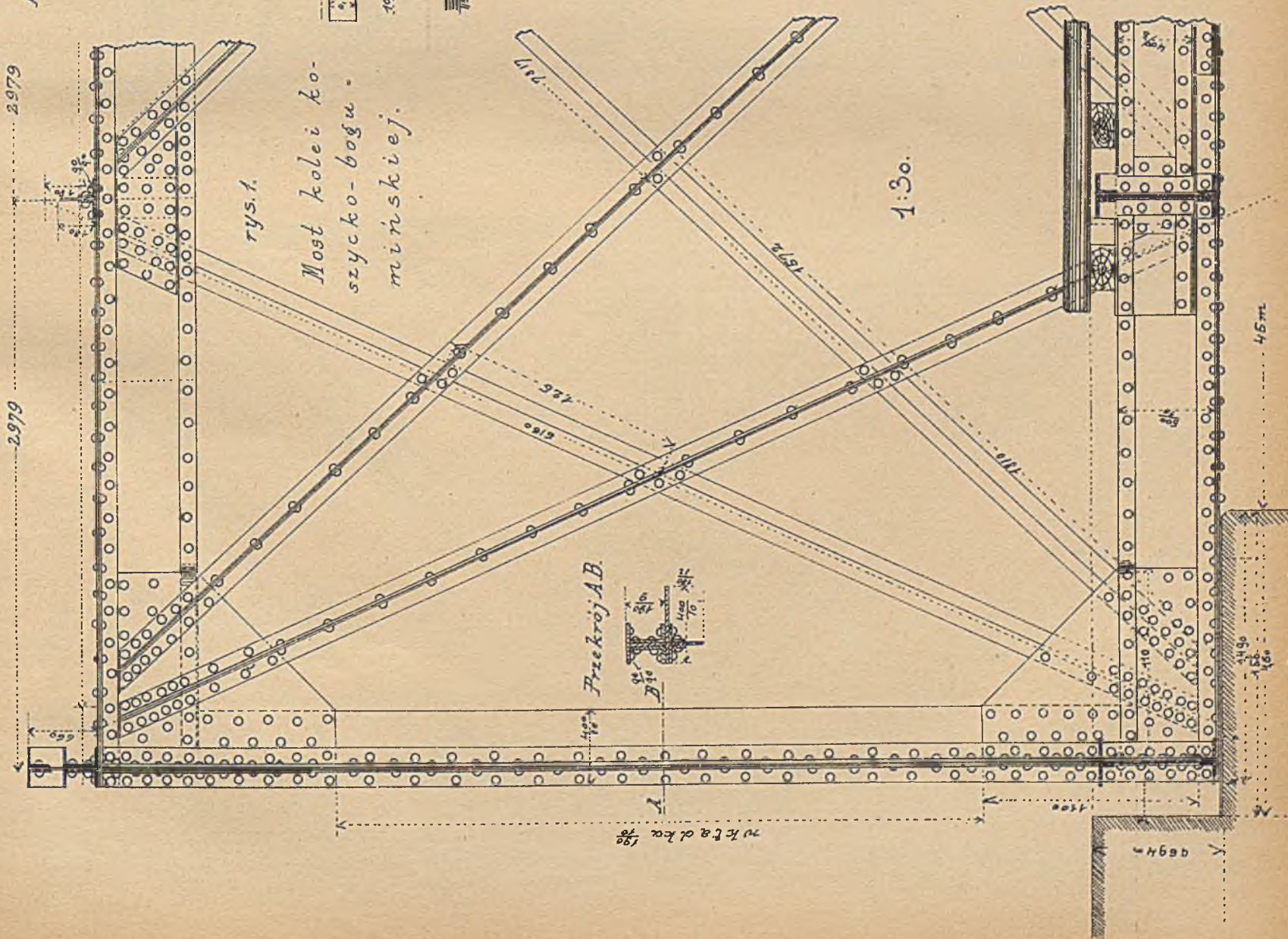

rys. 2.

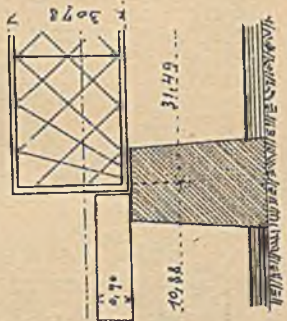

rys. 1.

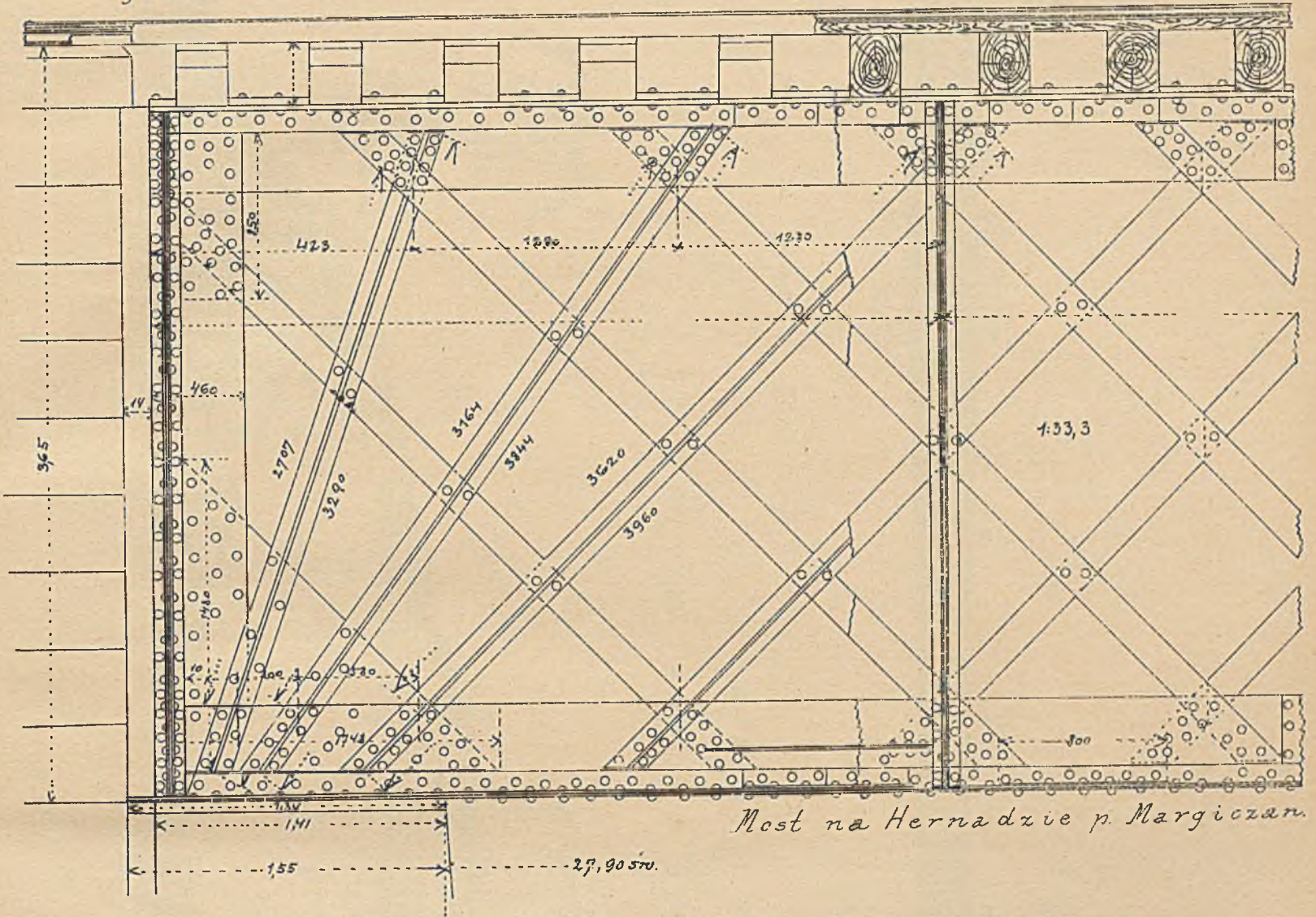

Most na Hernadzie p. Margiczan.

rys. 2.

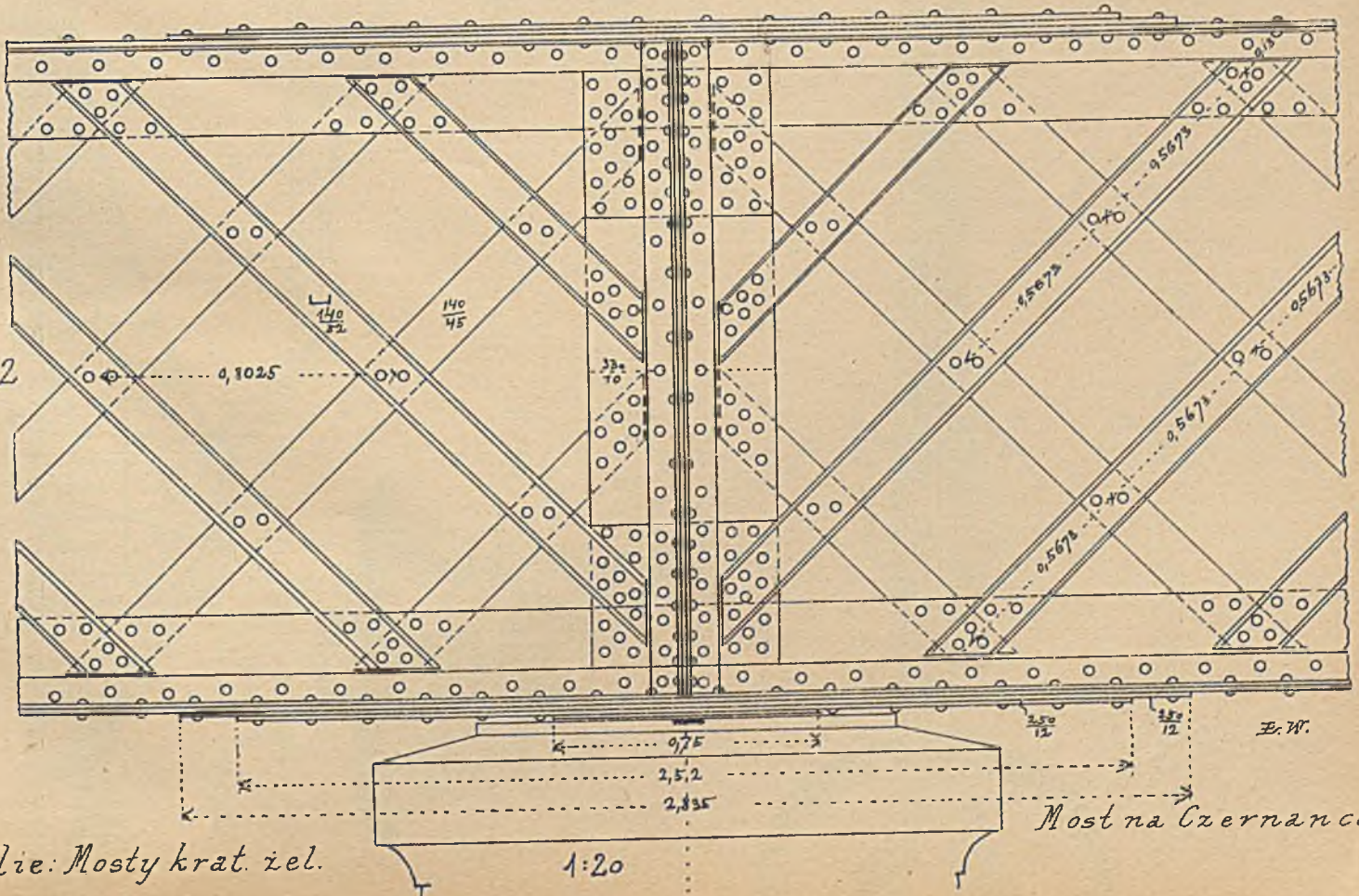

Most na Czernance.

rys. 1.

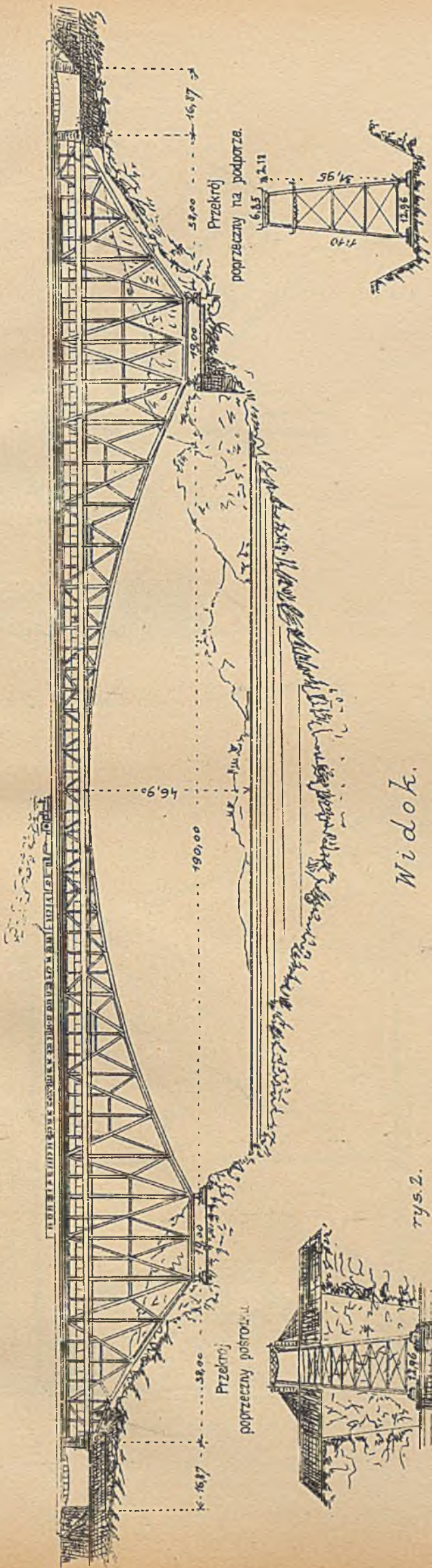

Widok.

Most przez Wilcxe Gardto na Dnieprze.

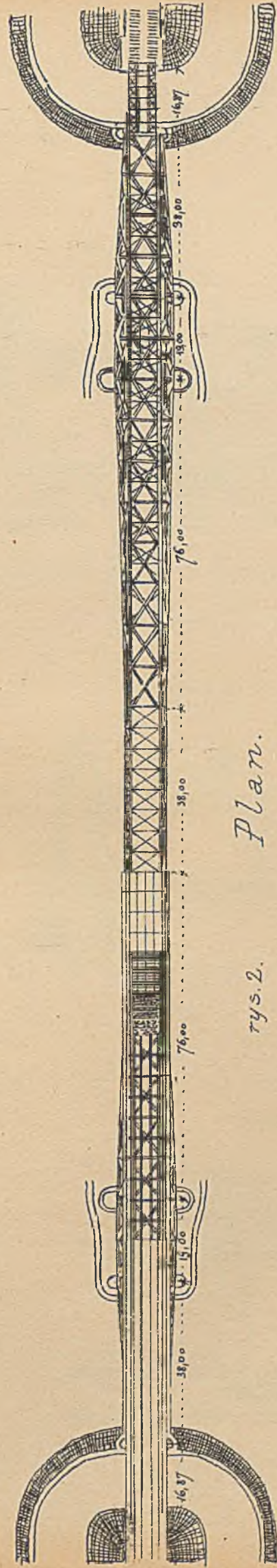

Plan.

rys. 2.

Dr. M. Thullie: Mosty krat. zel.

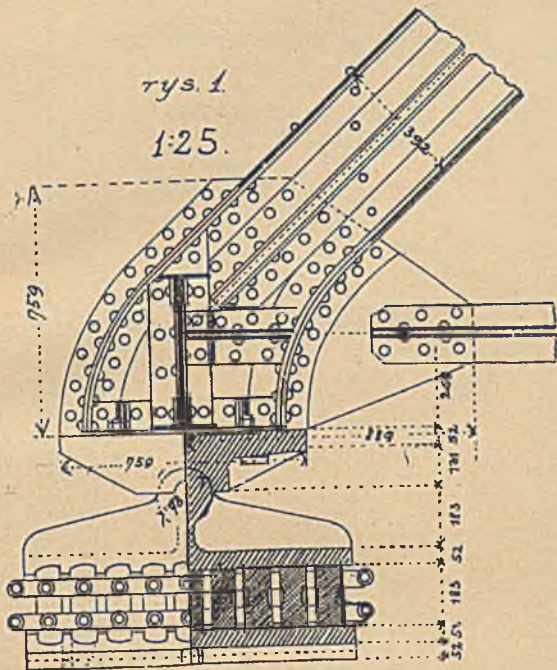

M. na Ruhrze koto Winz.

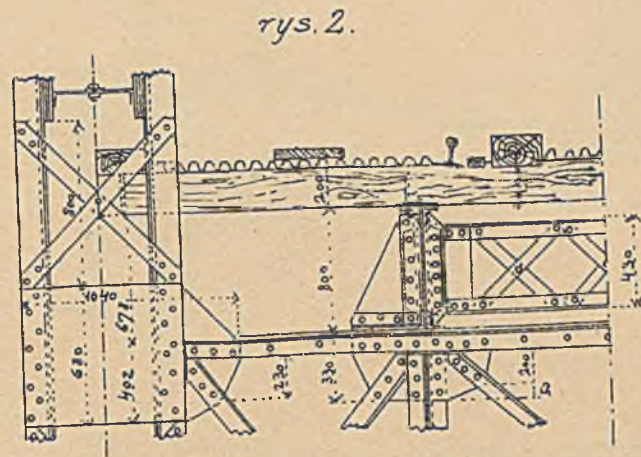

M. na Wettawie p. Černava.

rys. 3; 1:40.

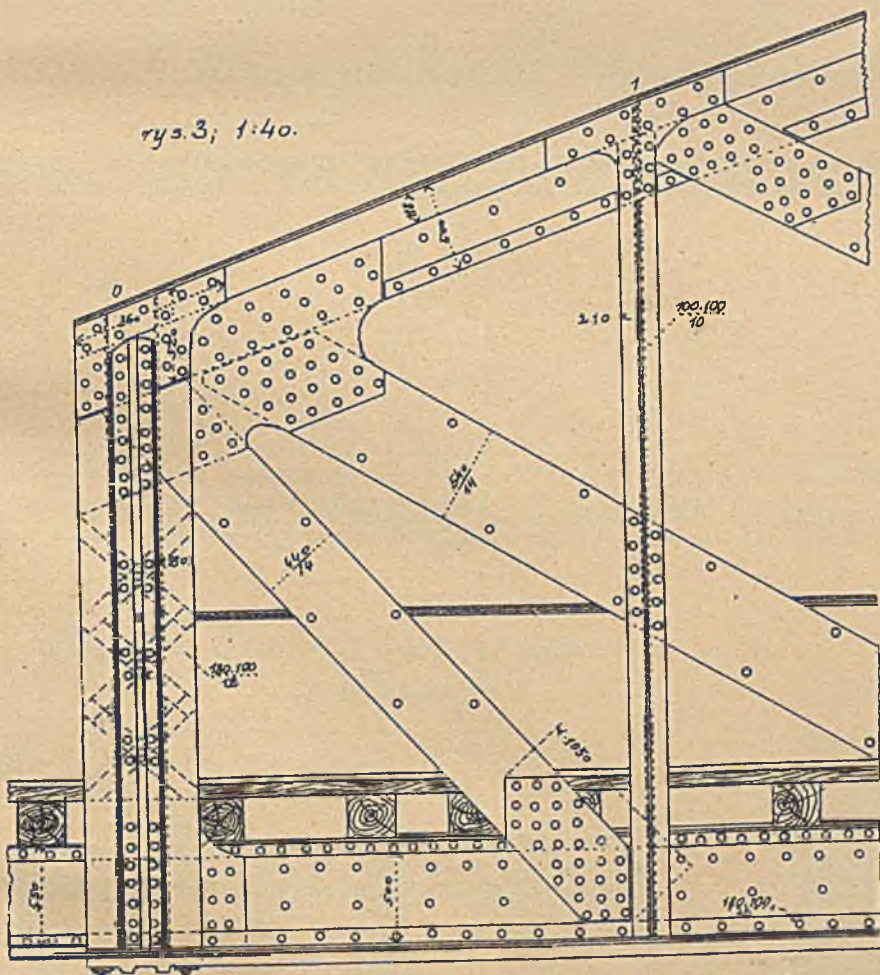

Most na kanale Dunaju w Wiedniu.

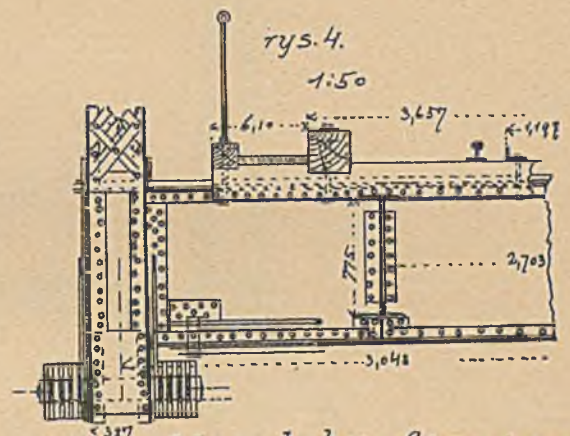

M. na Ohio kolei Cincinnati.

rys. 5.

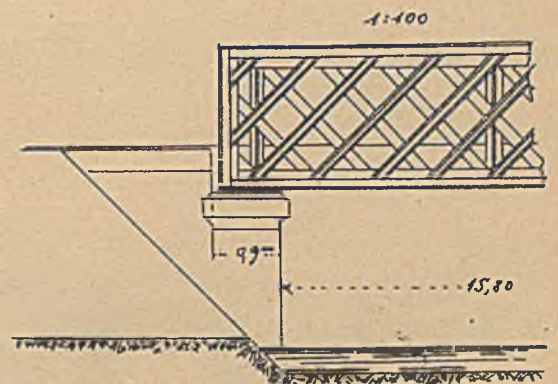

Most na Czarnance.

Rys. 1. Władukt pod Englisau.
1:80

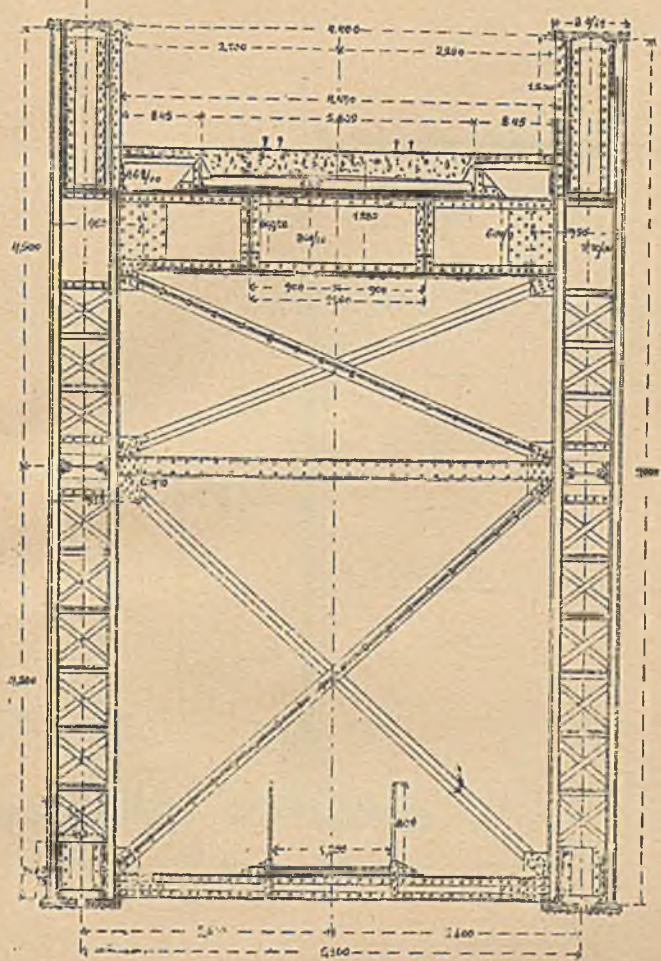

Rys. 2 a. Most na Moreli pod Bullay.
Przesło wielkie.

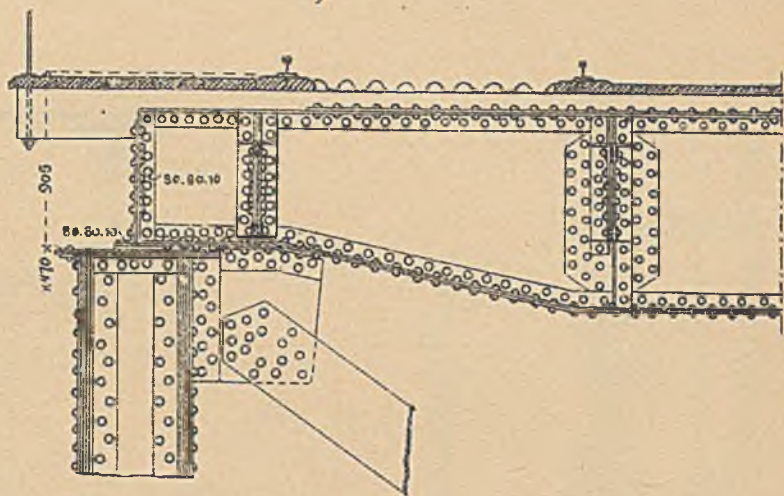

Rys. 3. Most na Sawie pod Conr.
1:550

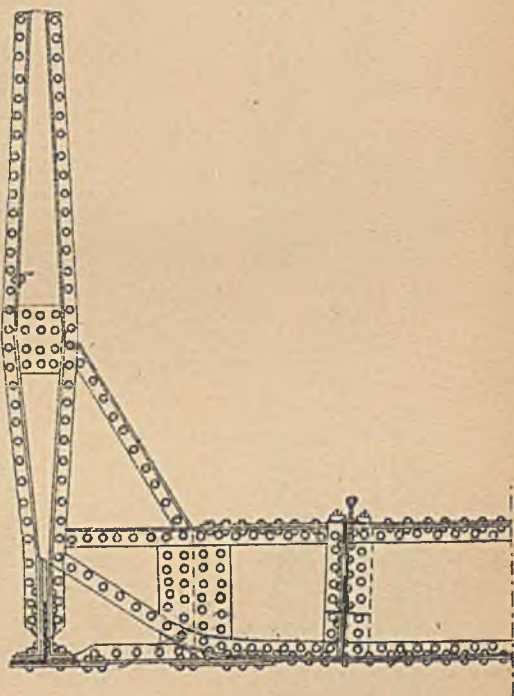

Rys. 4. Most na kanale Mانشesterkim.

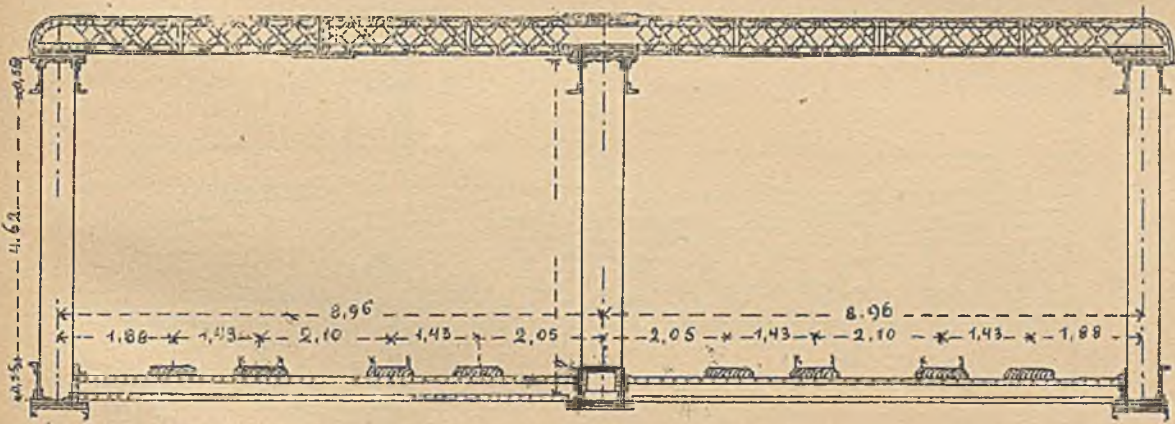

Rys. 2 b. Przekrój na poprzeczniccy
środkowej.

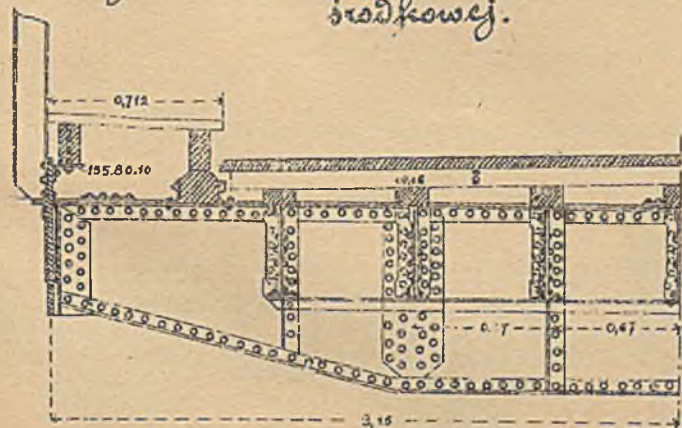

Rys. 2 c. Przesło mniejsze poprzeczniccy
skrajnej.

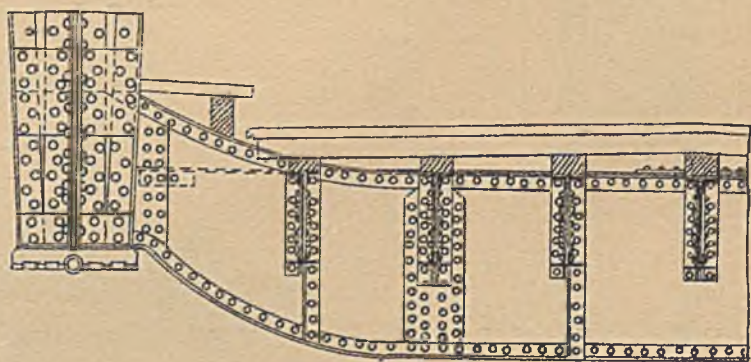

Pomost

Rys. 1. Mosty włoskie.

1:10

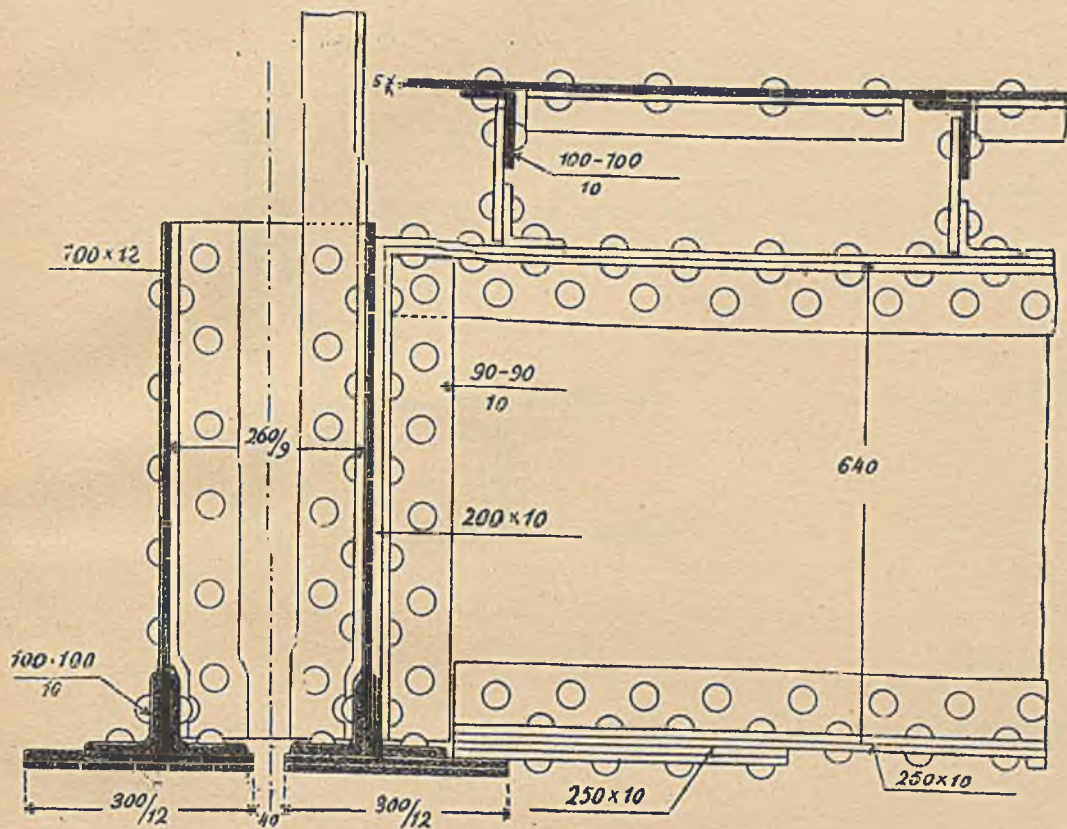

Rys. 2. Mosty włoskie.

1:10

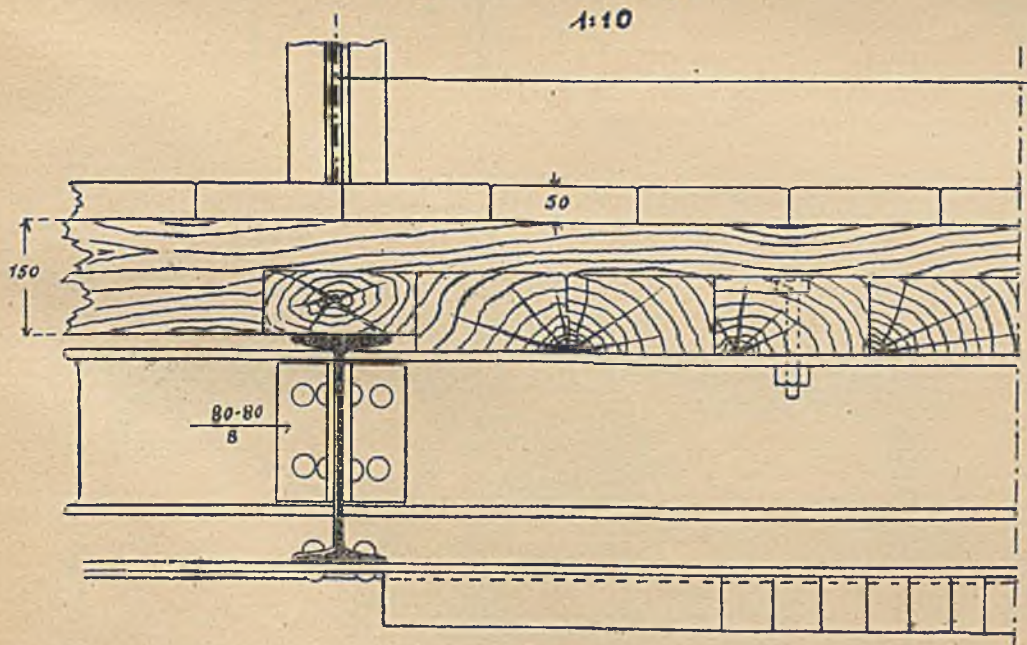

Rys. 3. Odbojnicemostu na Renie pod Horschheim.

1:12

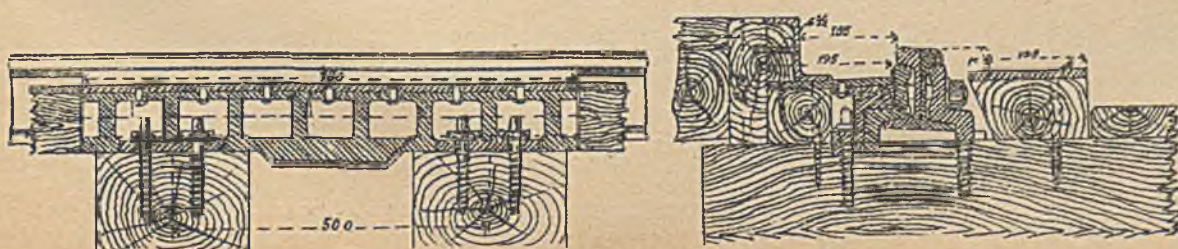

Rys. 4 b. Srebrkoj normalny.

1:40

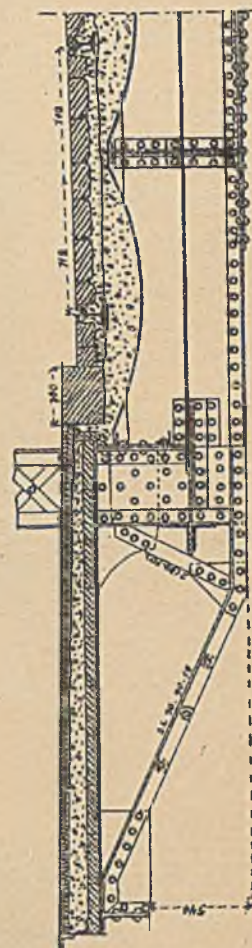

Most na Nordderelbe w Hamburgu.

Rys. 4 a. Srebrkoj nafilanie.

1:40

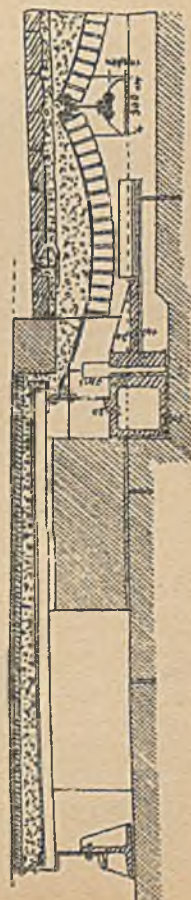

Połączenia podtuznic z poprzecznkami.

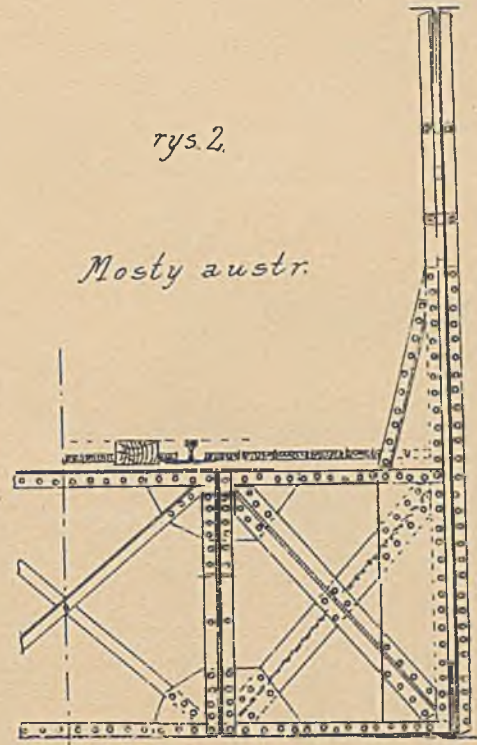
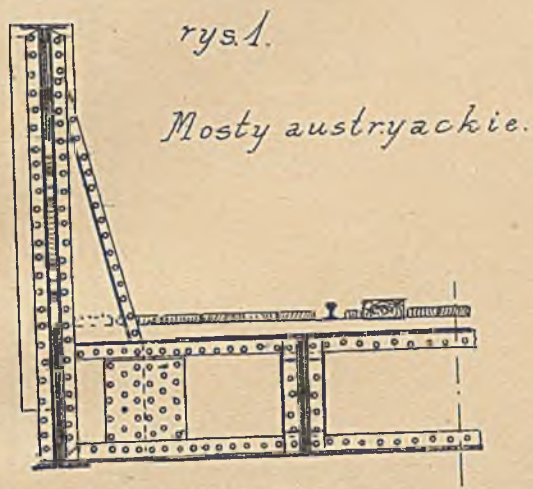

Most na Odrze w Boguminie.

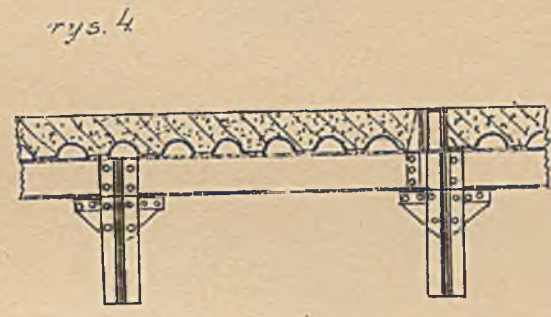
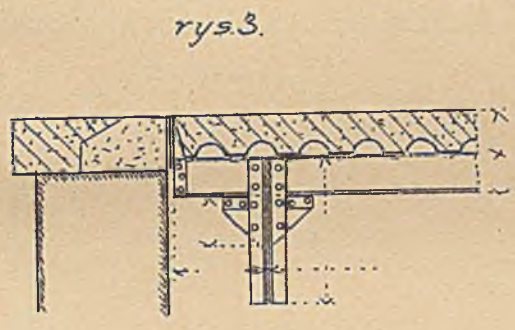

M. na Łabie p. Hamburgiem.

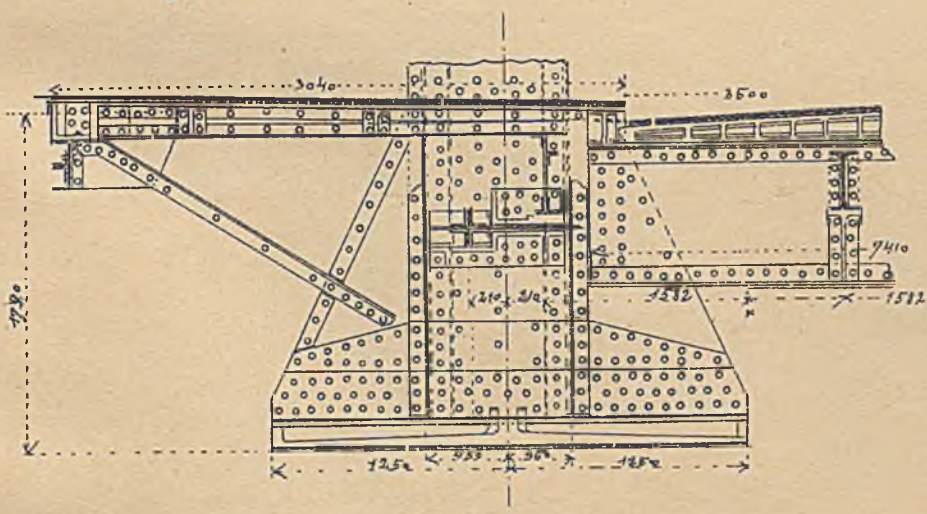

Mosty austriackie.

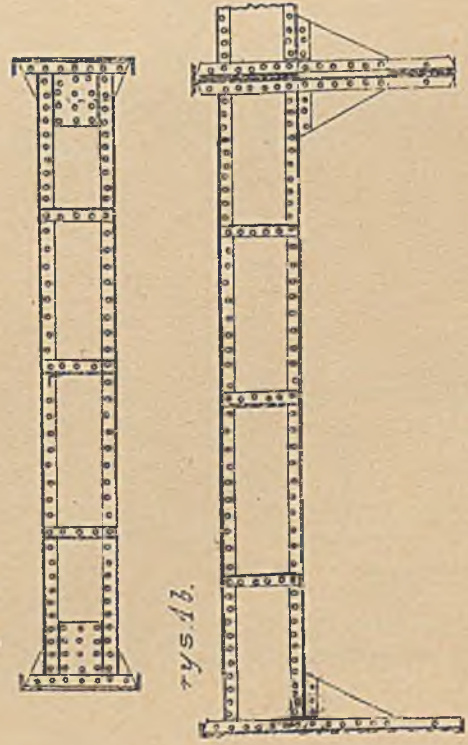

Dr. M. Thullie. Mosty krat. zel.

Wiadukt dd. Mery kol. Neuhof-Berdruvice.

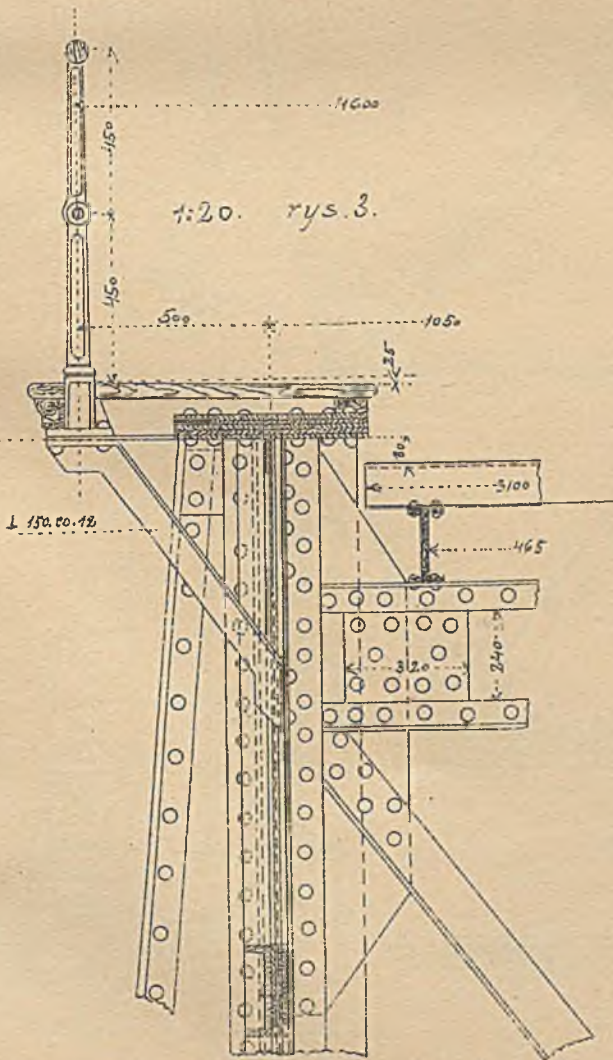
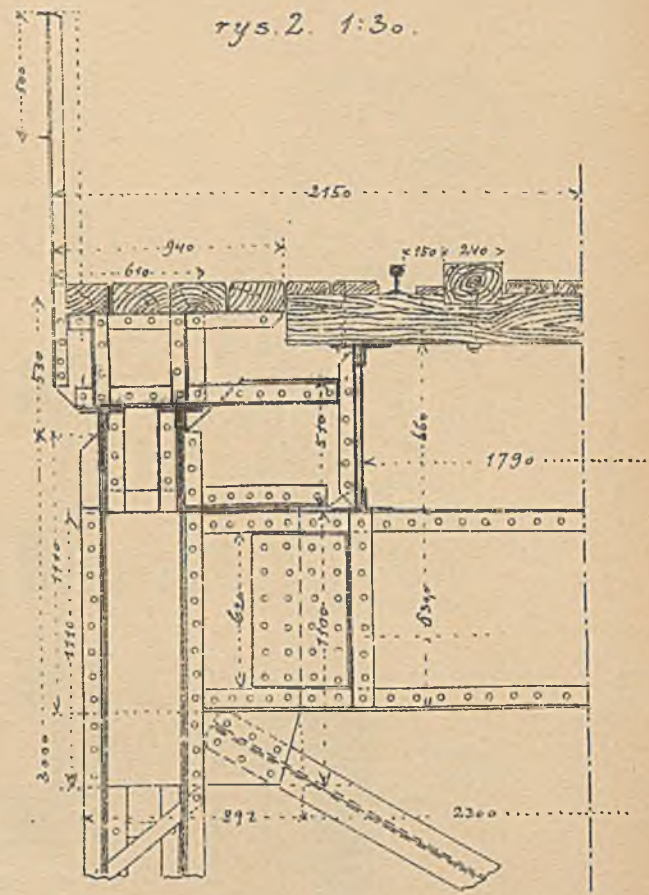
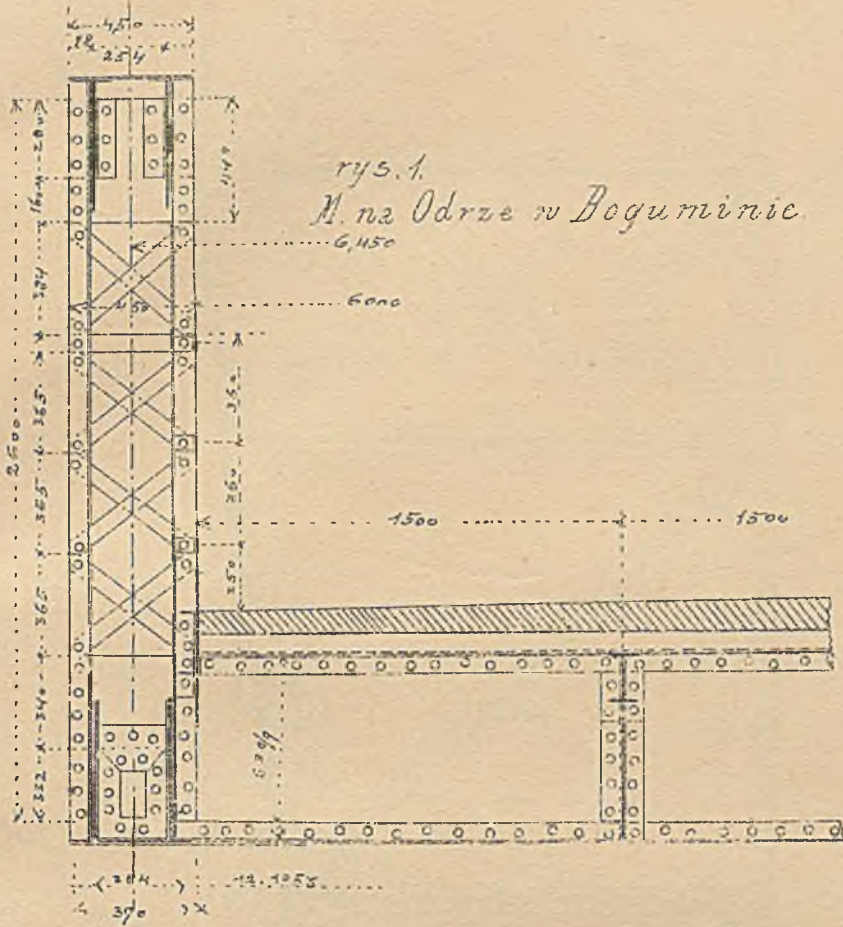

M. na Isarze p. Flalling.

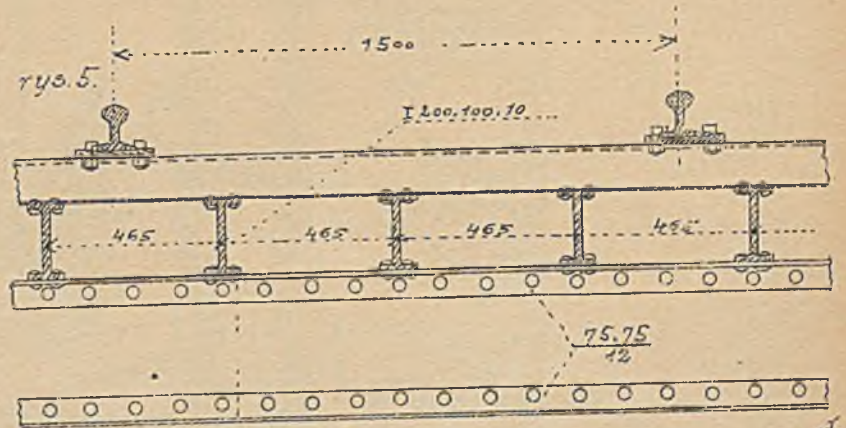
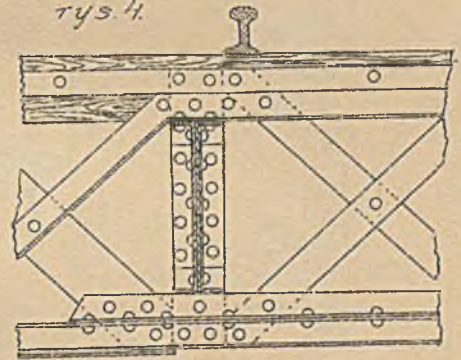

Most w Holeszowicach.

Tabl. 89.

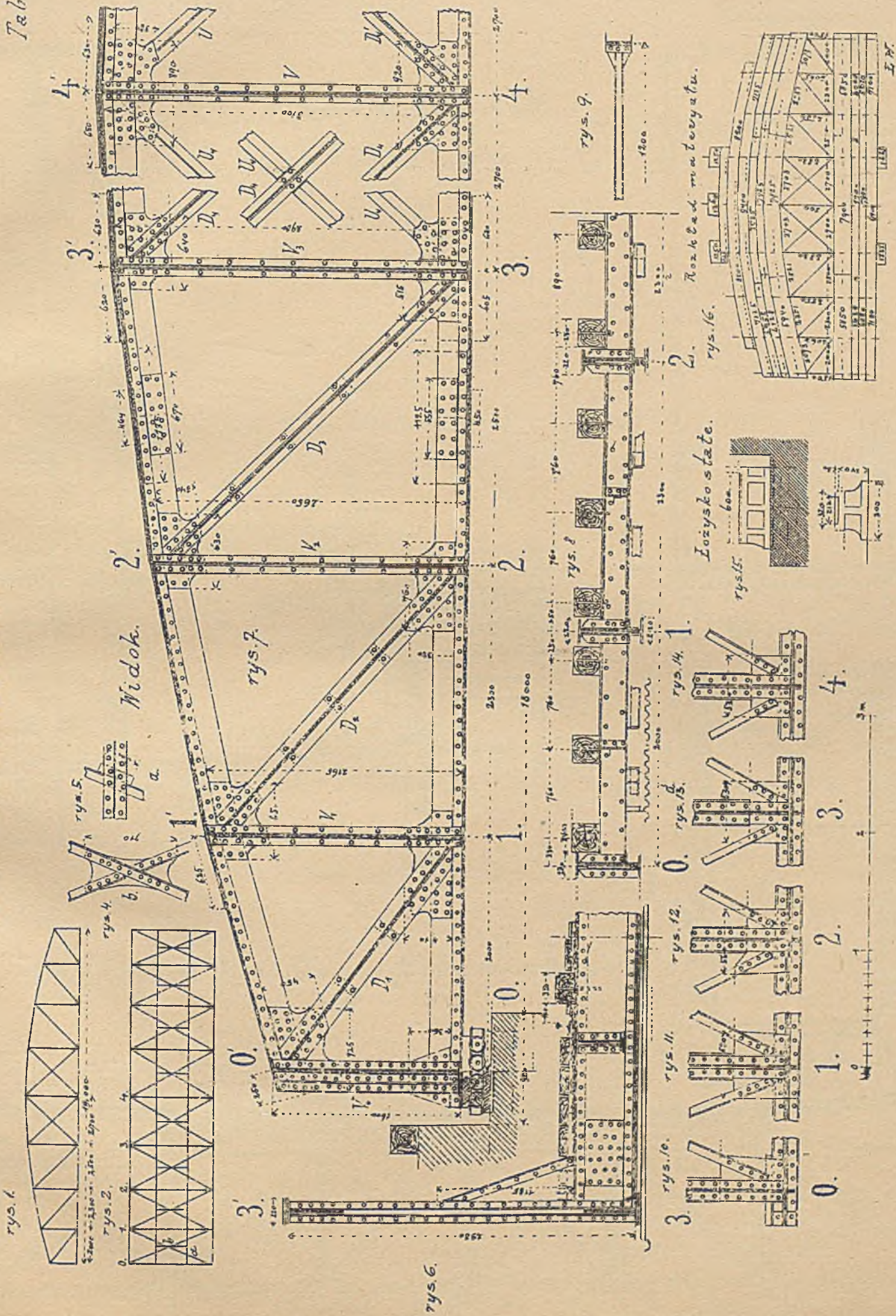

Dr. M. Thullie. Mosty krat. iel.

Spiekrojoje rozpięskte.

Rys. 1. Most na Norderelbie w Hamburger.

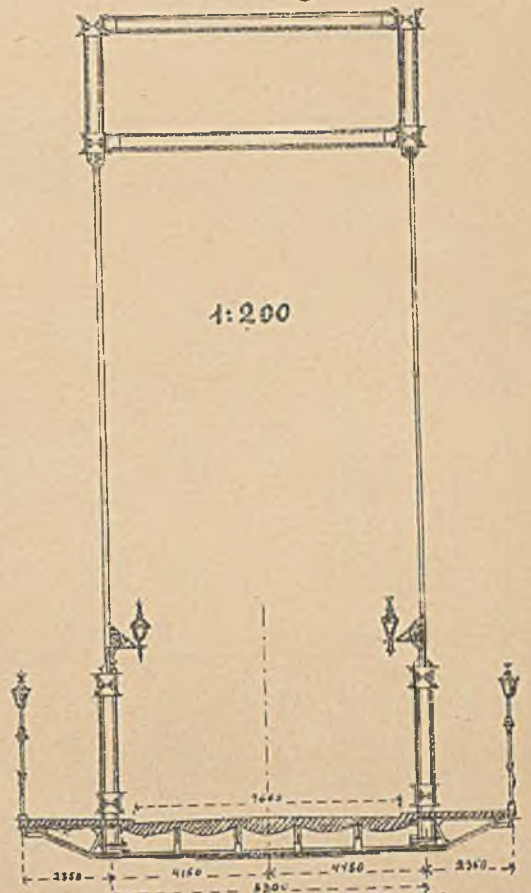

Rys. 3. Most na Ziblu. 1:125

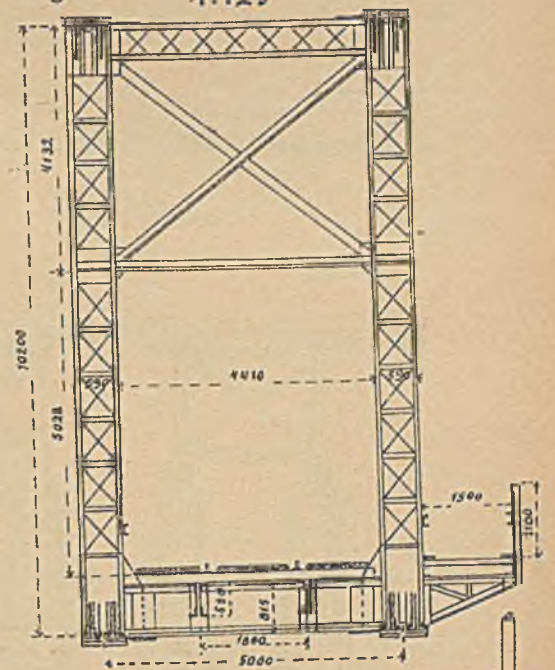

Rys. 2. Most na Drawie pod Swietoslawem.

1:15

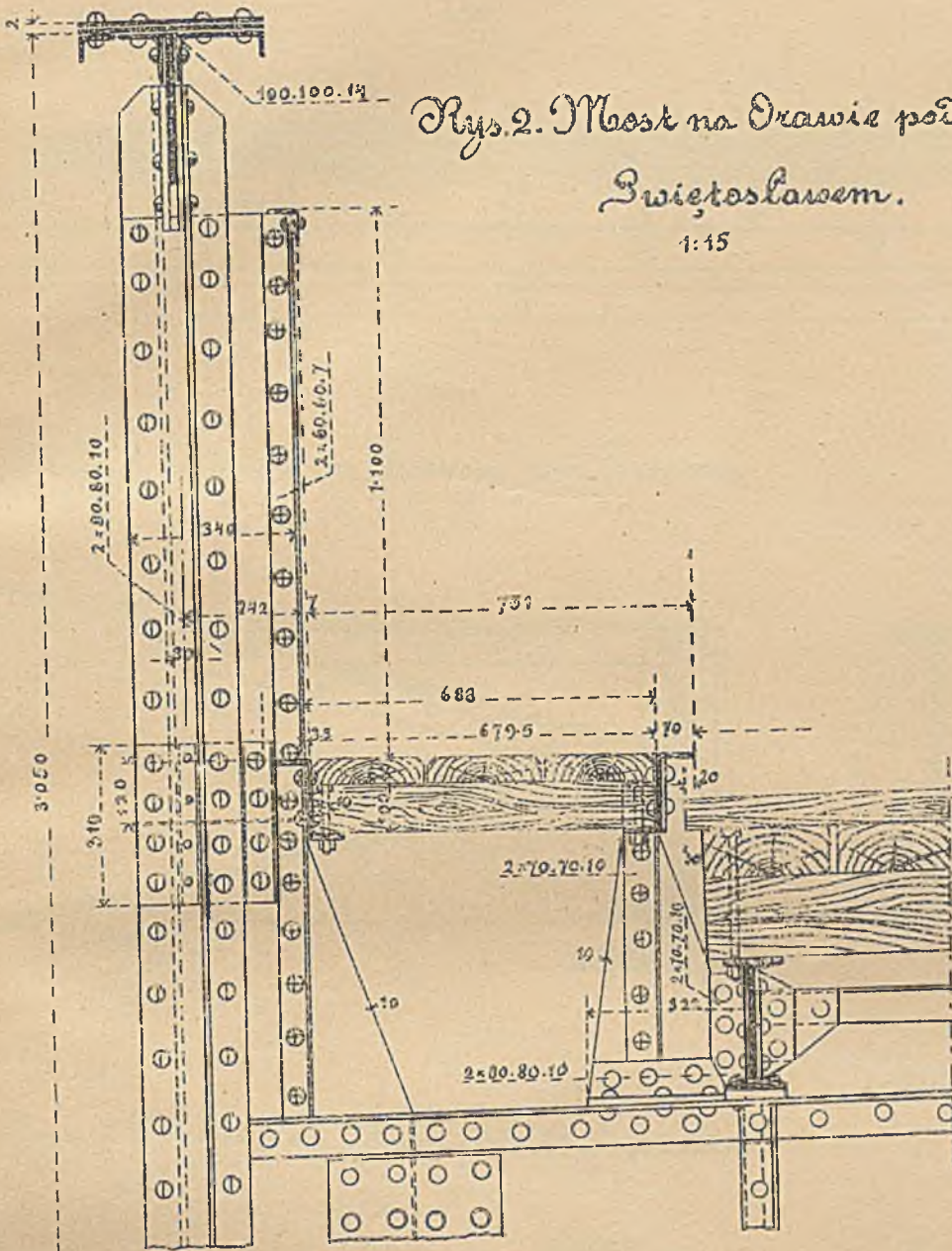

Rys. 4. Most Mirabeau na Sekwanie w Paryżu.

1:100

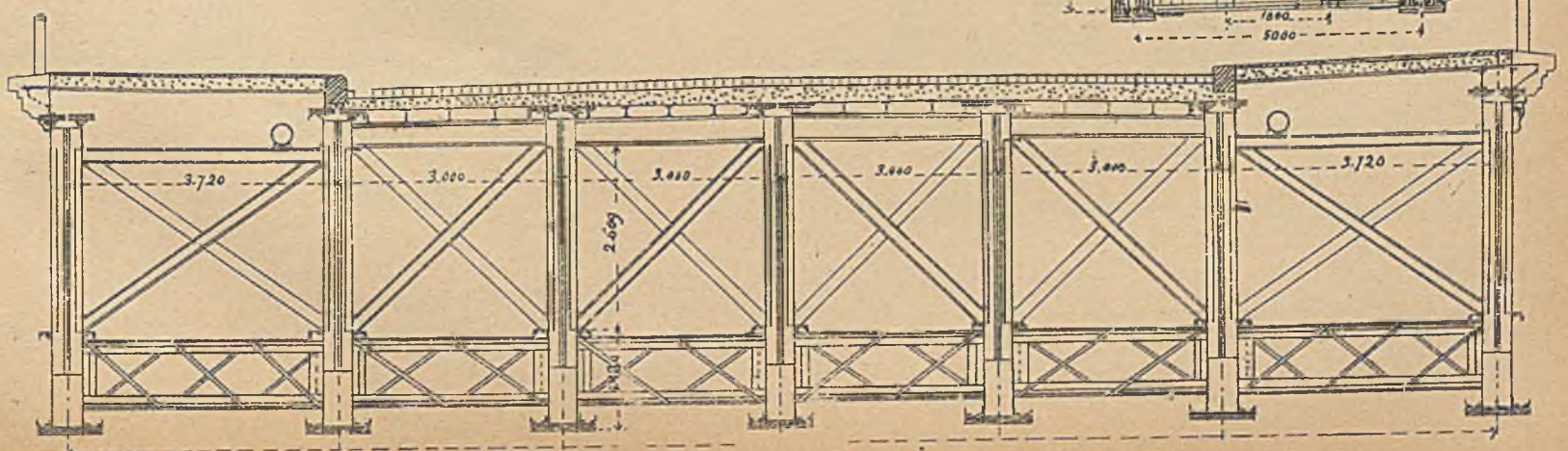

Przekroje poprzeczne.

Rys. 1. Most kolejowy berliński.

1:50

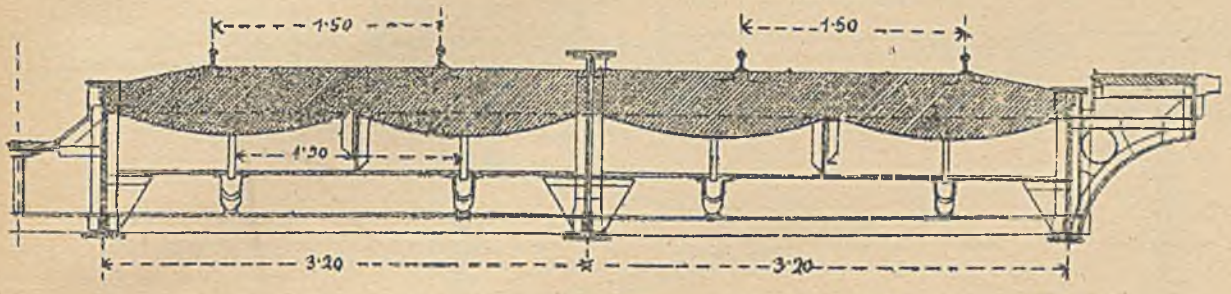

Rys. 2.

Staloc mostów

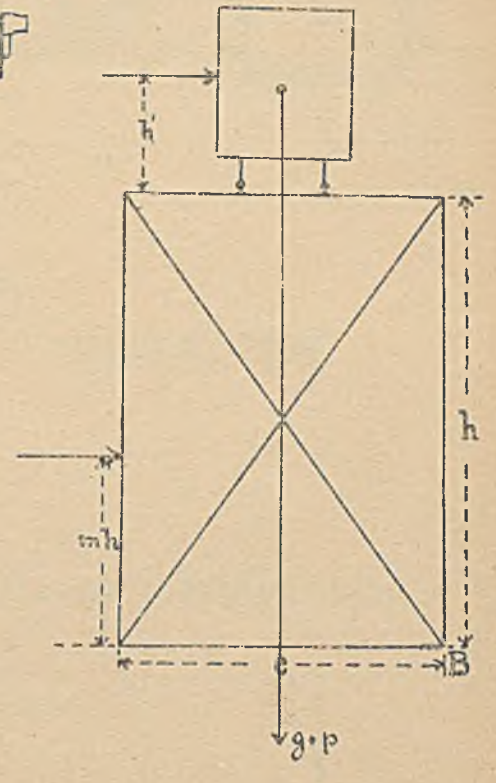

Rys. 3. Most na Dunaju pod Sarrauwą

1:15

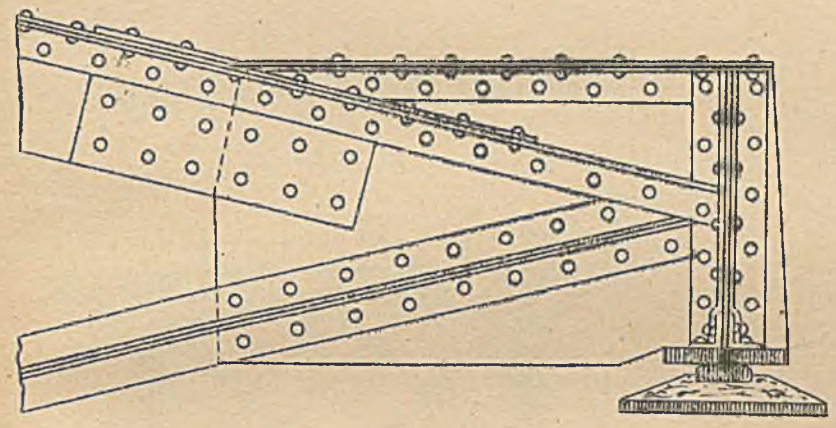

Rys. 4. Most nad Bida pod Budygostem.

1:15

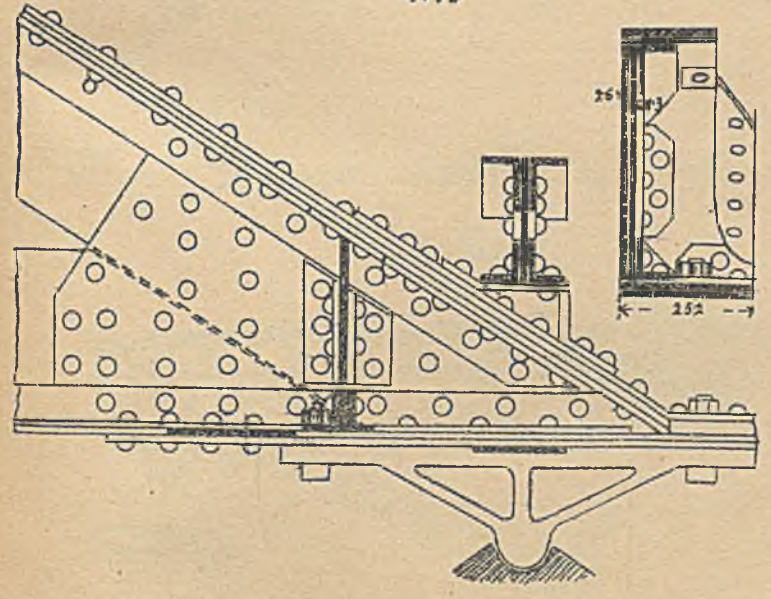

Rys. 5. Most nad Sprewią w parku

Bellemie.

1:200.

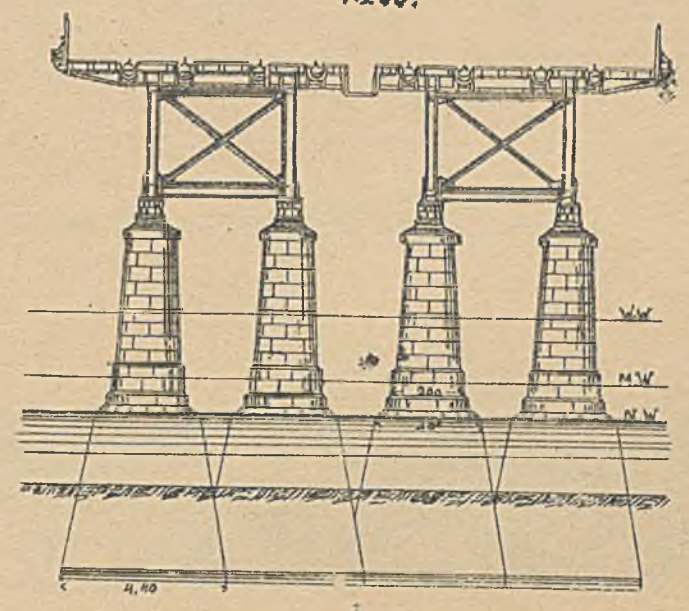

K.S.

Рис. 1. Мост над Спрениа в парку Беллевуе.

1:40.



Рис. 2. Мост на Рене под Валдбулт

1:100

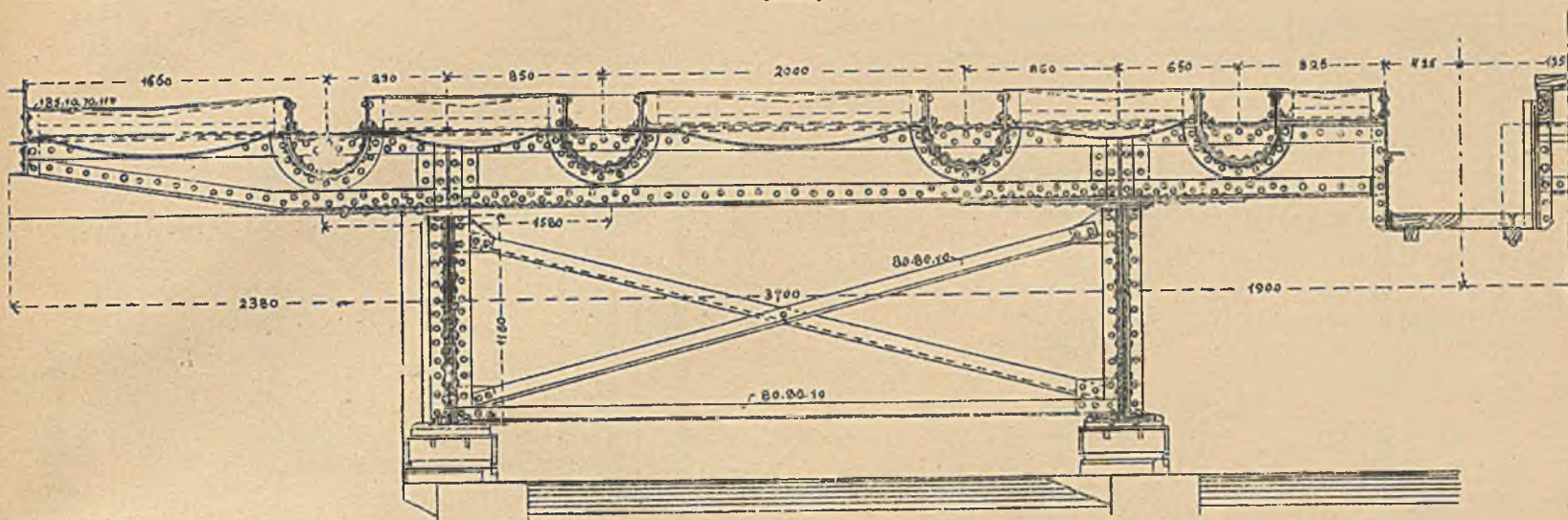

Рис. 3. Мост на Висле под Коштрзгнем.

Стыг ехадникова.

1:30

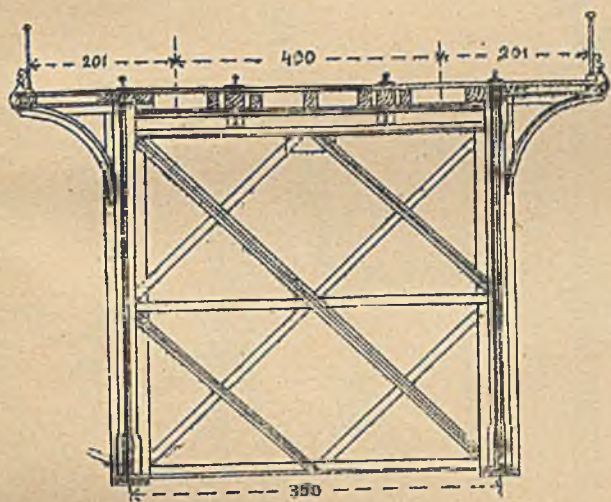

Рис. 4. Сз снгоѡт виадукта над Нидо, под Ассенкеим.

1:50

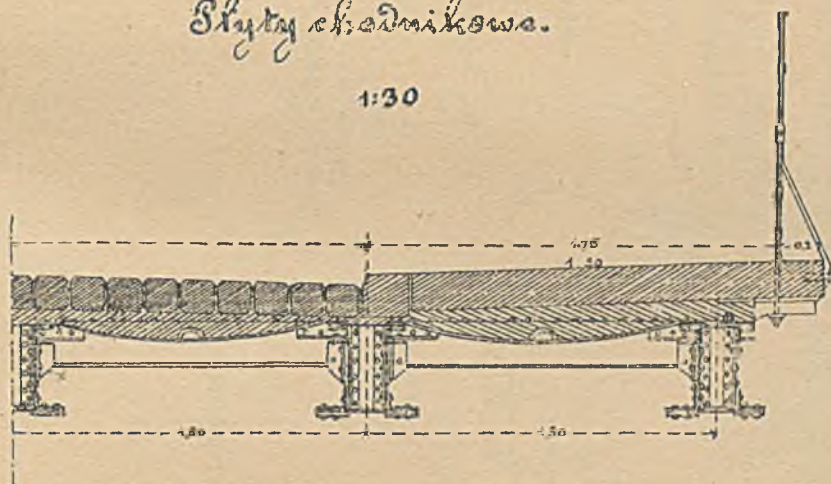

Рис. 5. Мост Тегетхофа в Виеднне

1:100

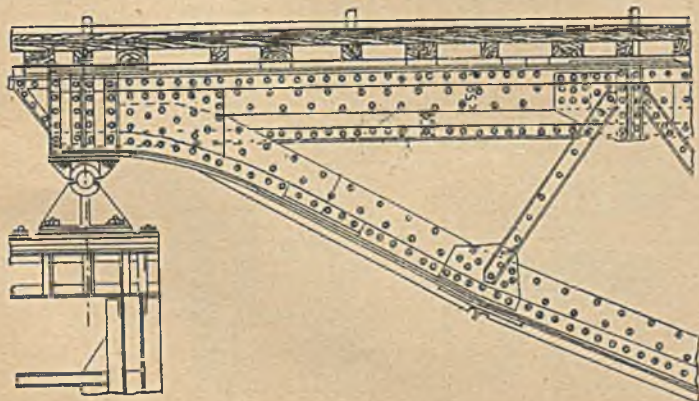
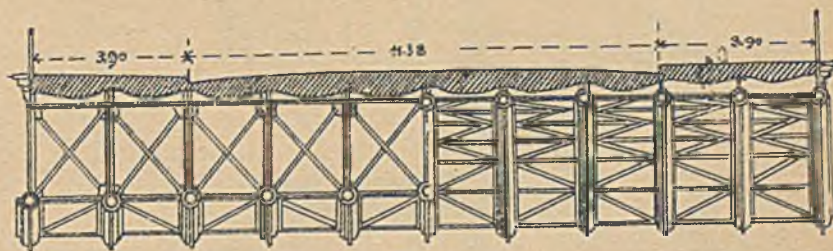

Most drogowy na Dębrzy w Donicenu.

Rys. 1. Widok.

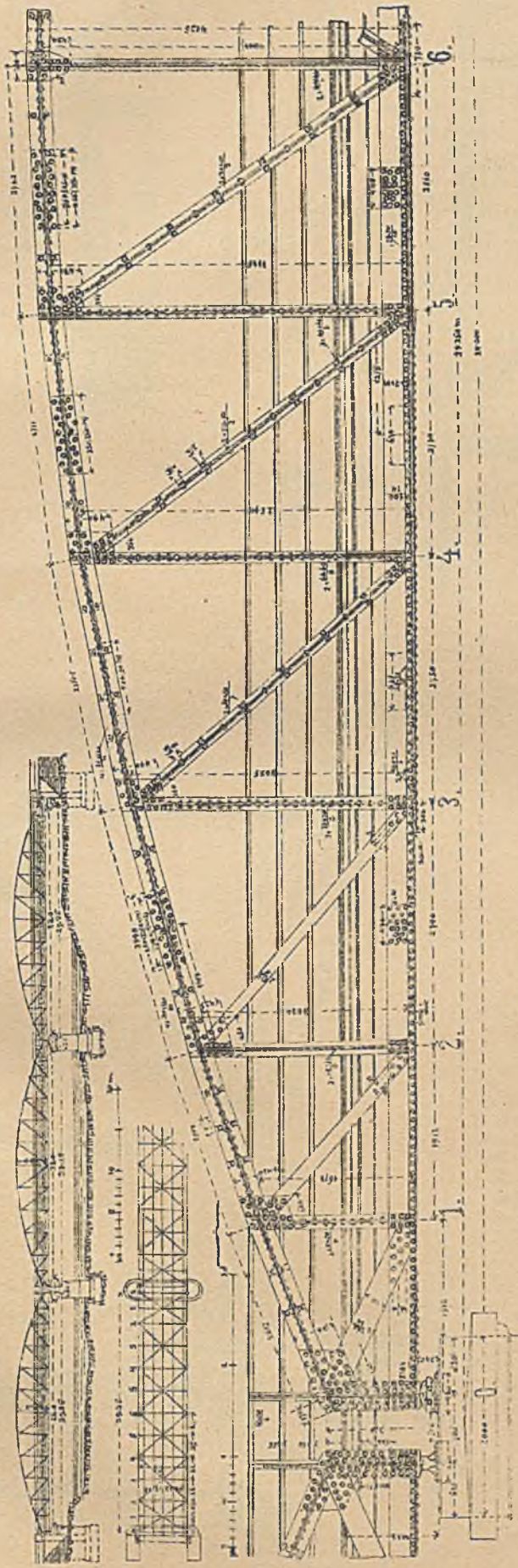

- 1.
- 2.
- 3.
- 4.
- 5.
- 6.

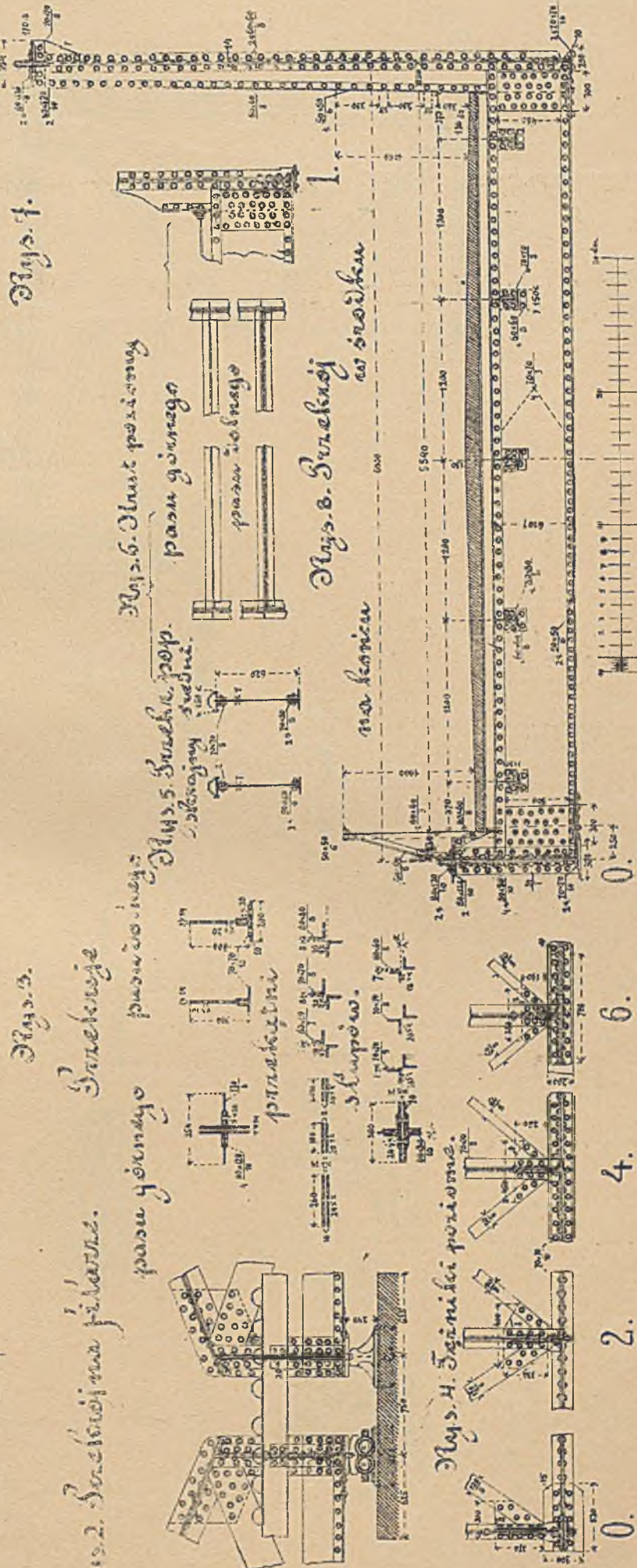

1874

Most na Iserze

Tabl. 94.

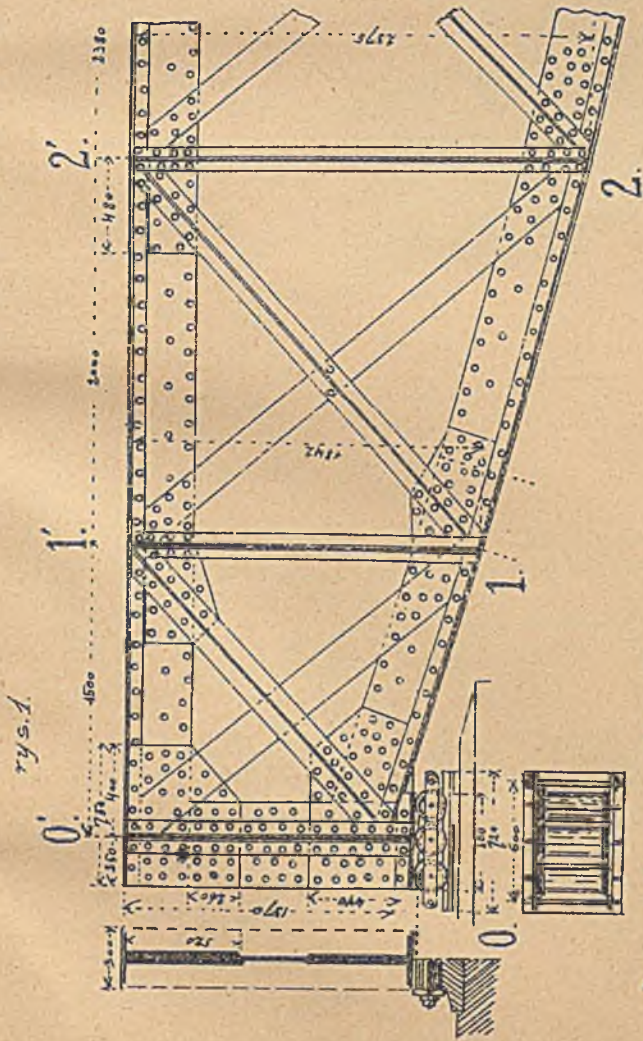

Iozysko watkowe.

rys. 4.

styk:



gornego } pasek
dolnego }

rys. 5.

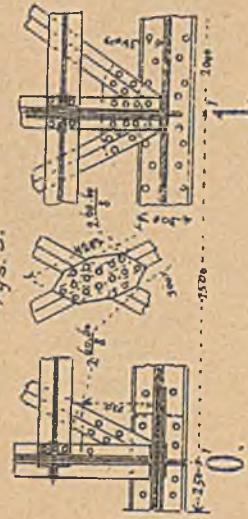

rys. 2. Widok.

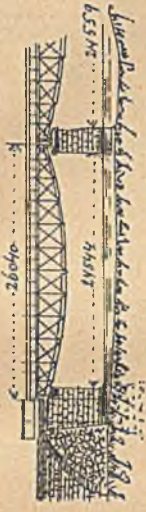

rys. 3.

Przekroj poprzeczny.

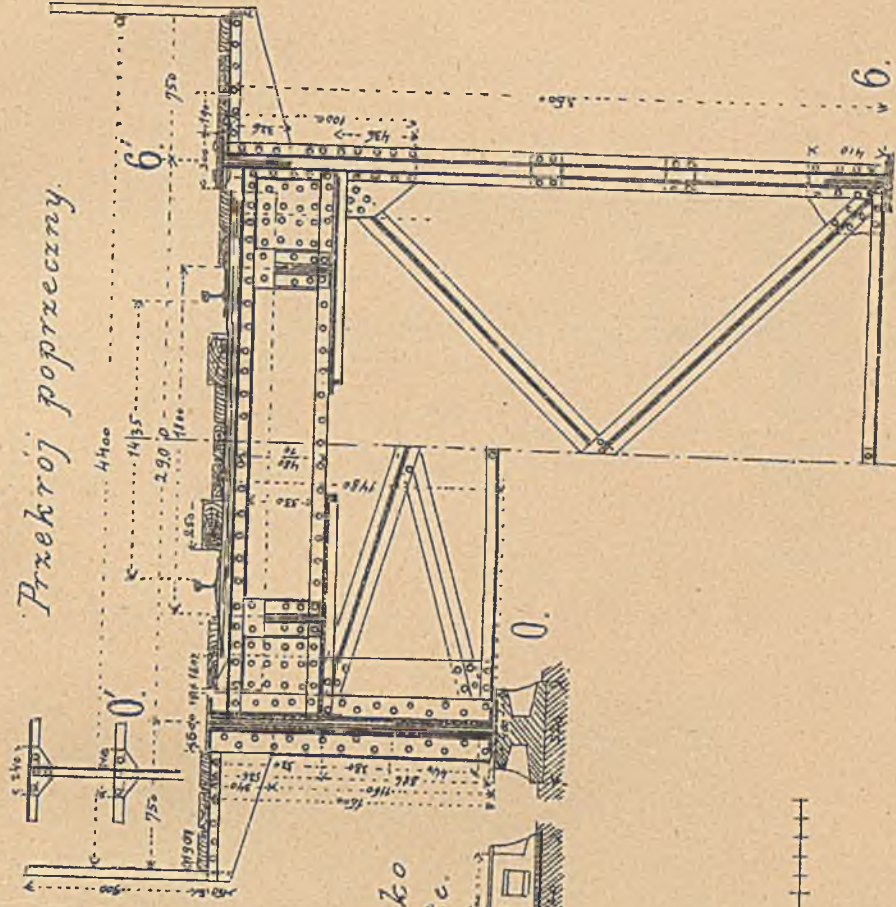

Iozysko statek.

Podziatka.



Dr. M. Thullie. Mosty krat. zel.

Ustrój poprzecznic.
rys. 1.

Tab. 95.

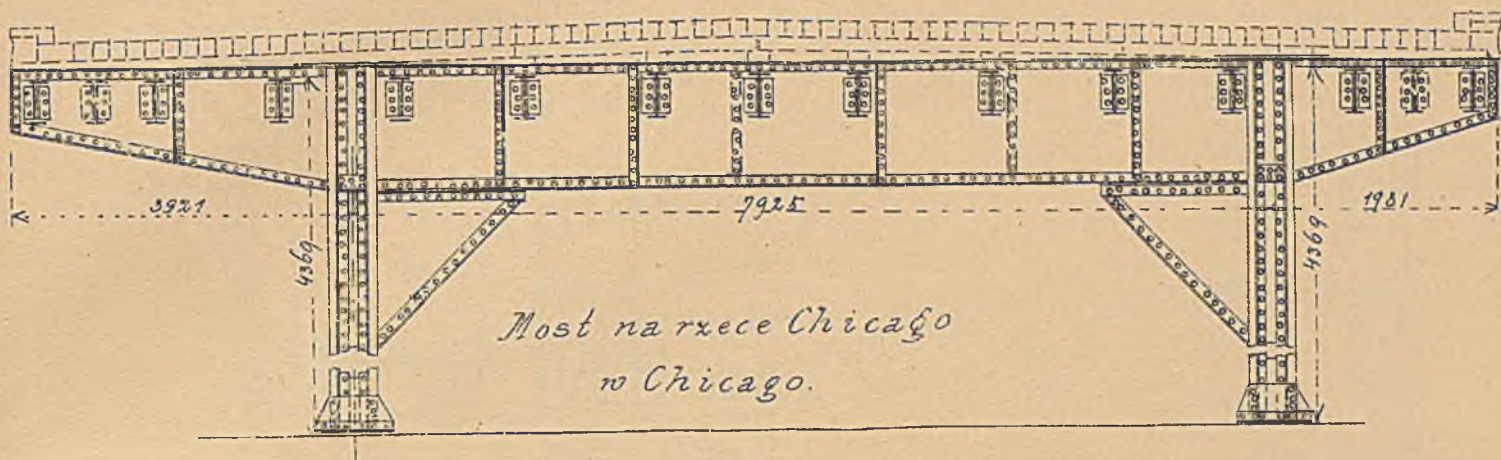

Most na Belaji
kolei Samara - Ufa.

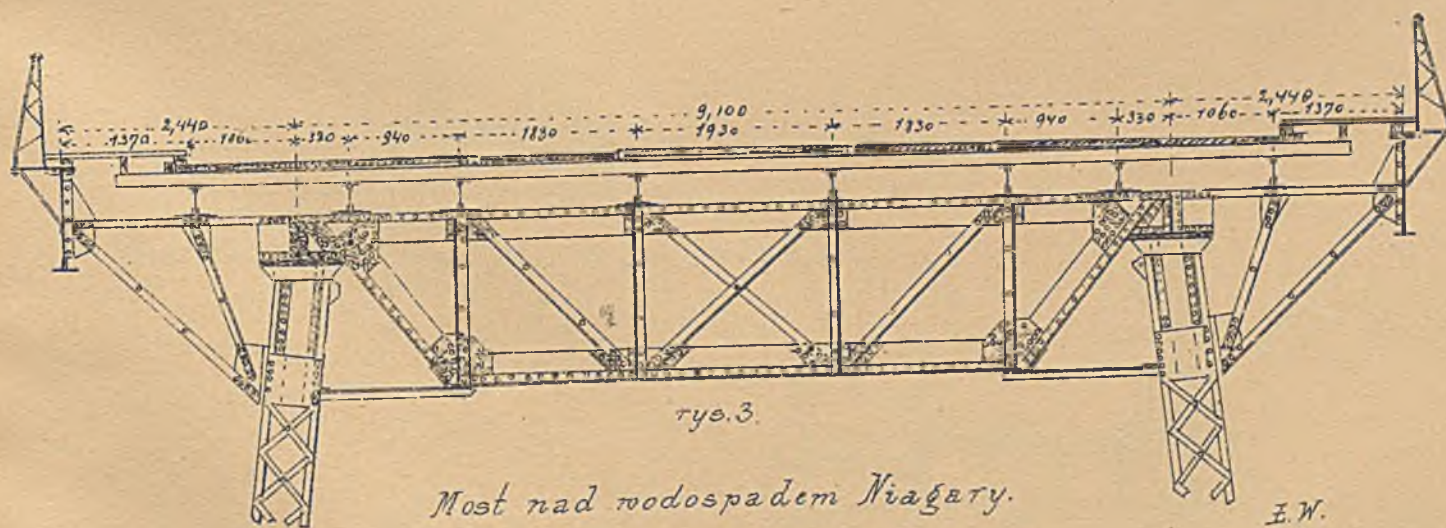
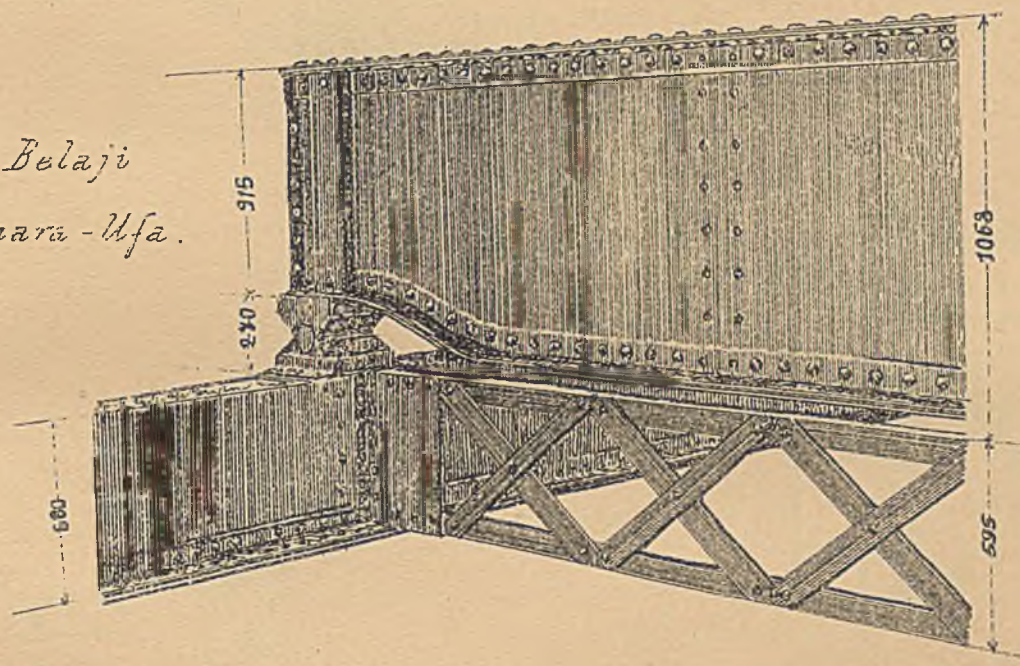

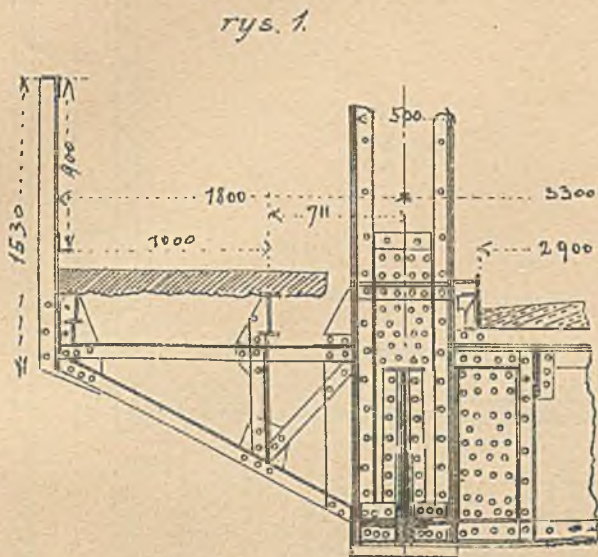

M. na Inie k. Simbach.

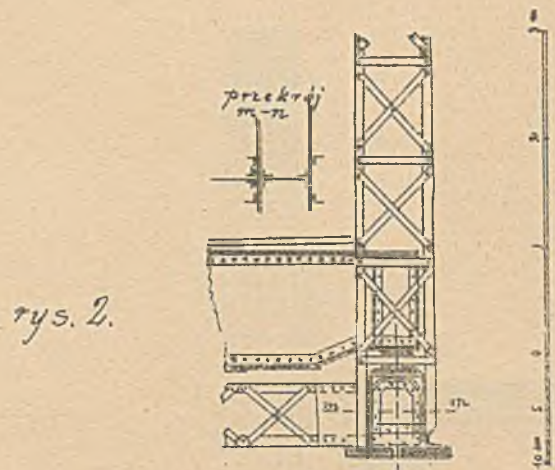

Most na Belaji k. Samara-Ufa.

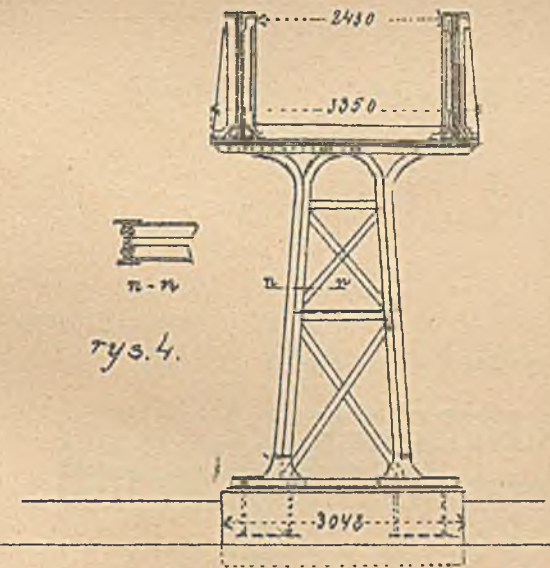

Most na ulicy Sinclair w Helenburgh.

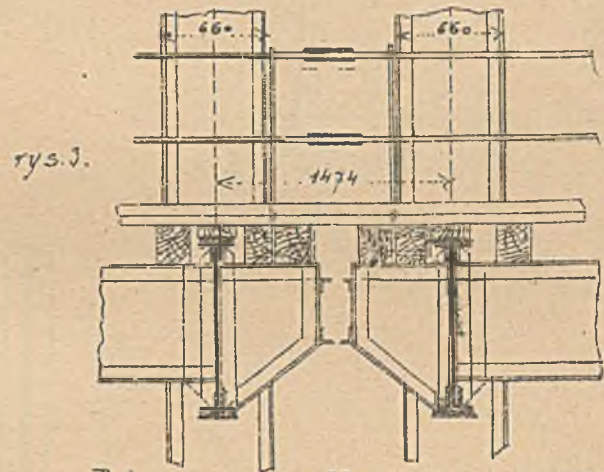

Połączenie podłużnic z poprzecznymi.
M. na Belaji.

Dr. M. Thullie: Mosty krat. żel.

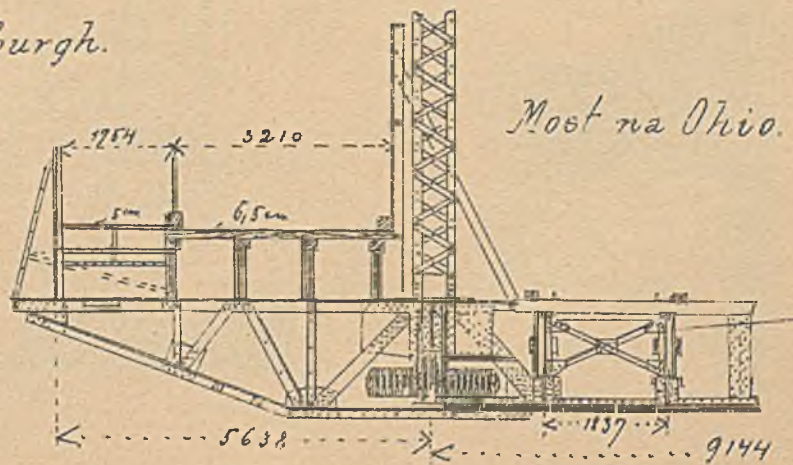

Most na Ohio.

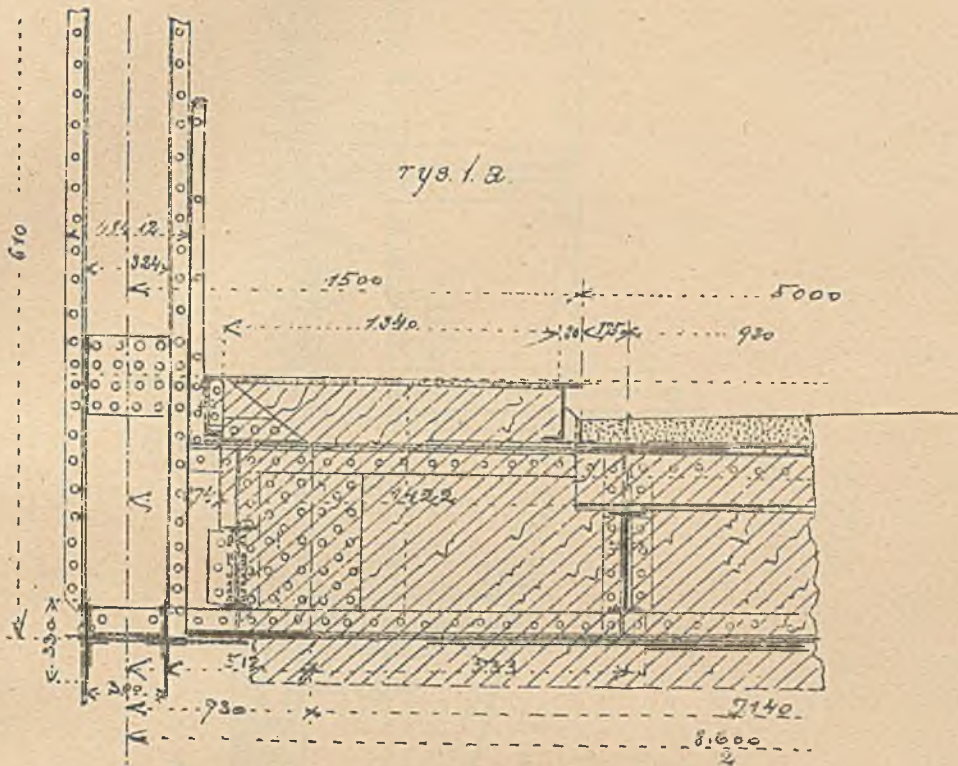

Most na Salcachu p. Lauferi

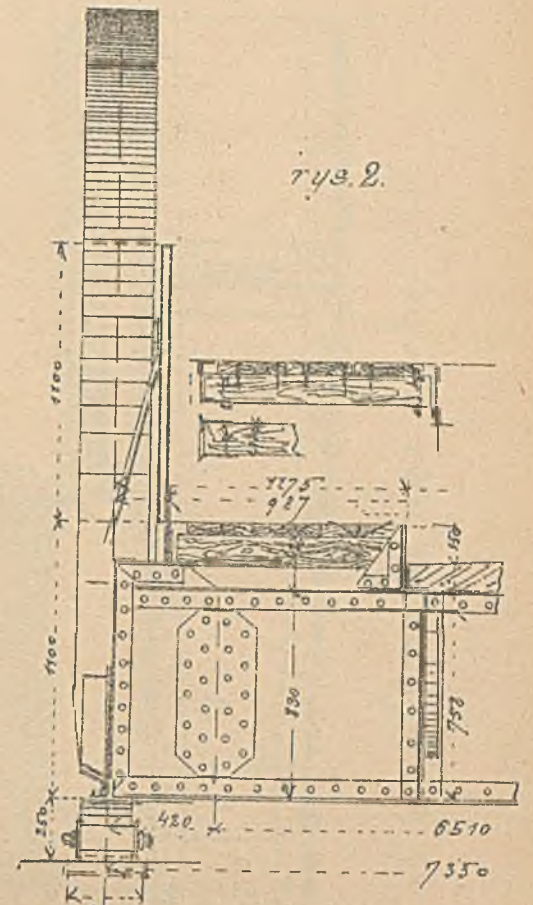

Most na Odrze w Studzienkach.

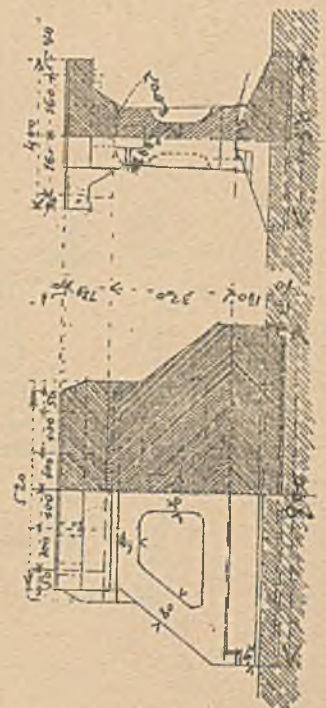
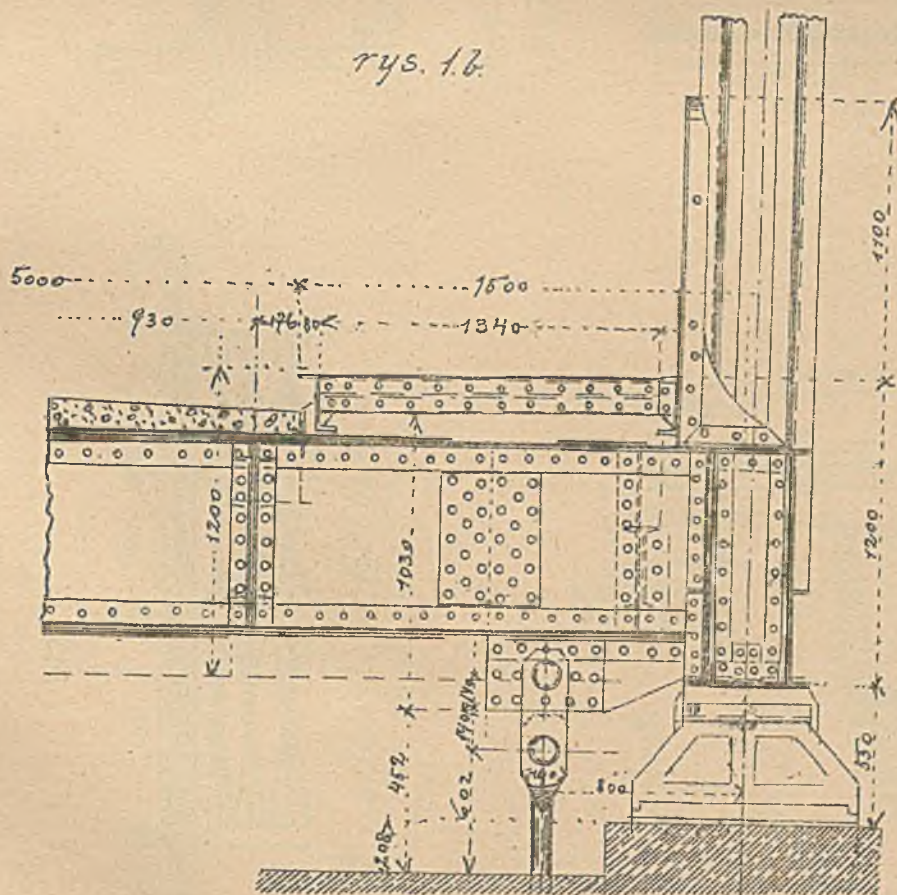

rys. 1.

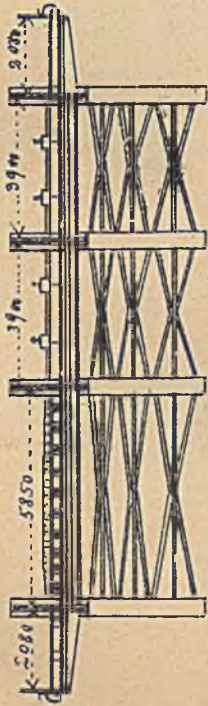

M. na Renie v Koblenzci.

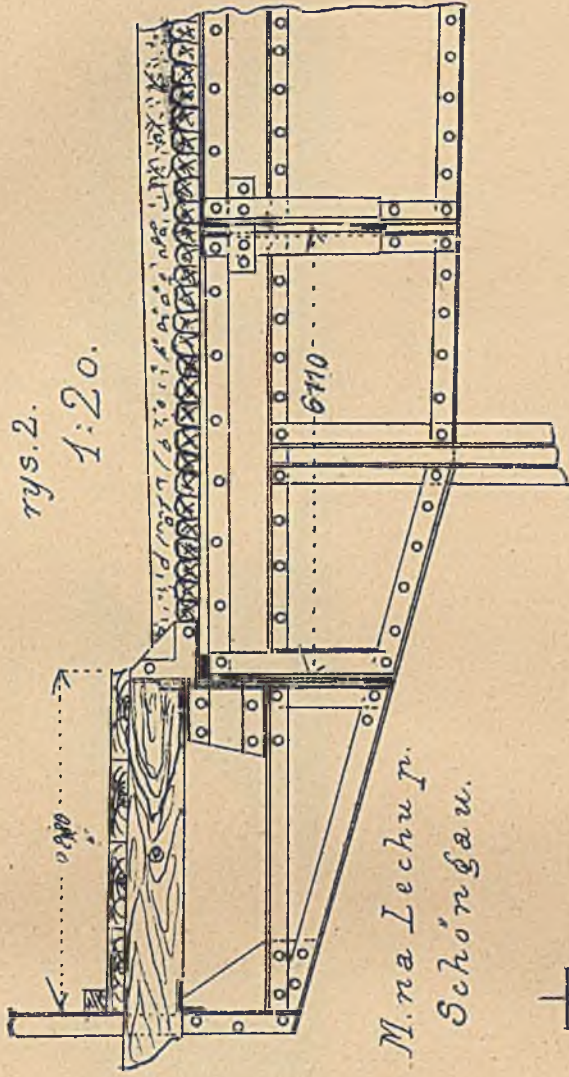

M. na Lechu p. Schönau.

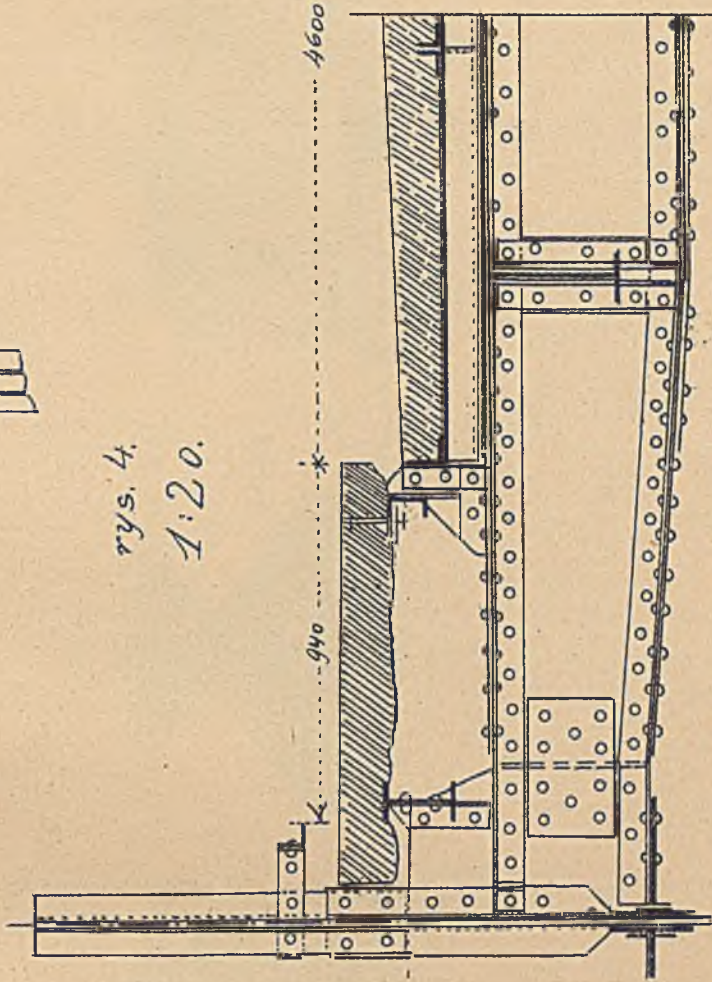

M. na Altmühl pod Eichstädt.

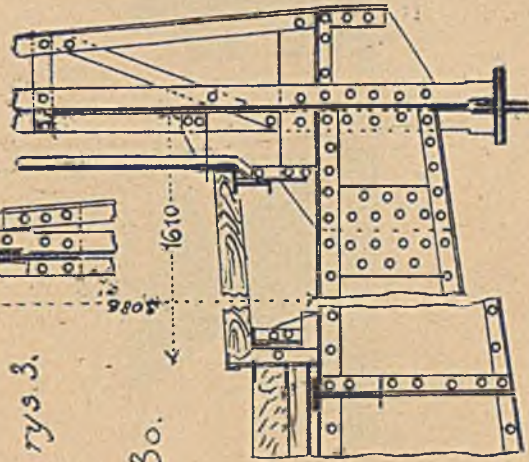

M. na Dunaju p. Passau.

Żelazka mostu kolei syberyjskiej na Obie.

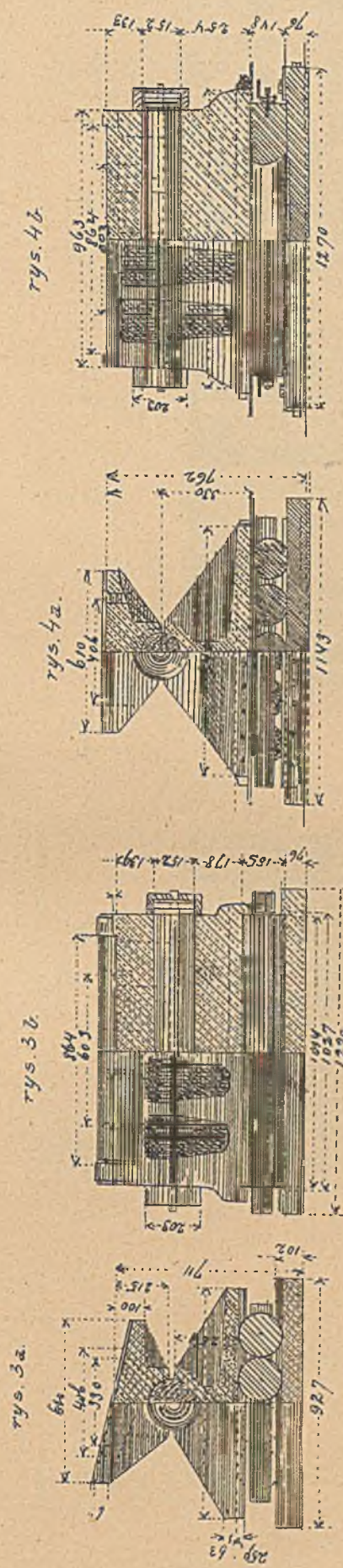
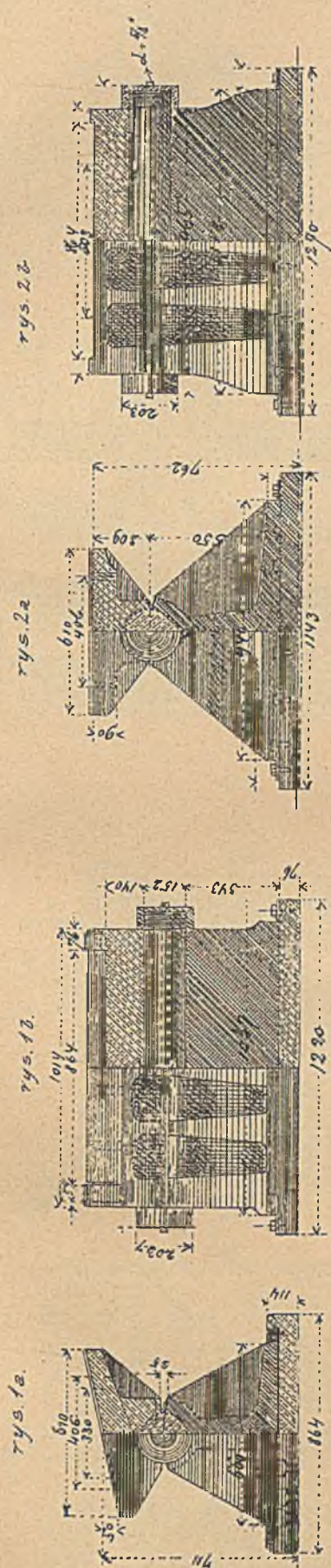

Dr. Thullie: Mosty krat. zel.

rys. 3.W

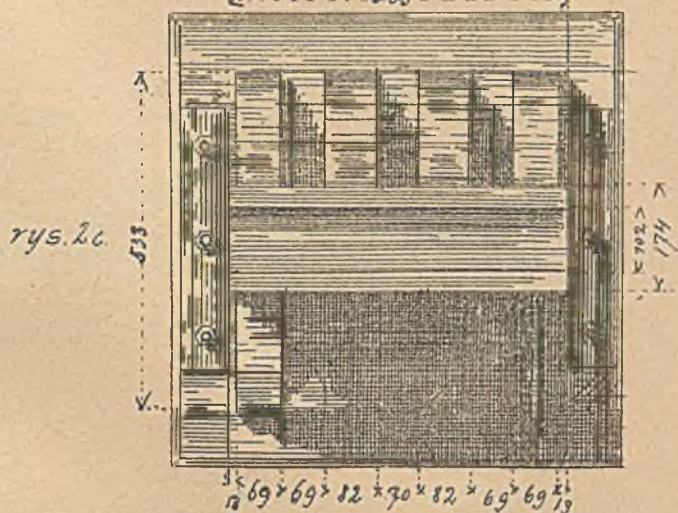
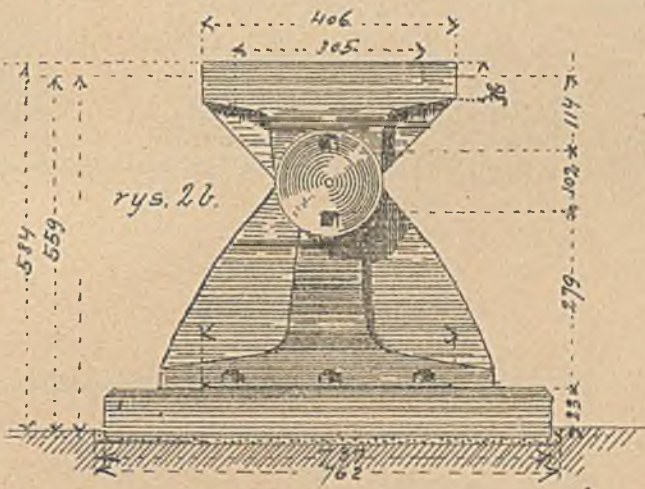
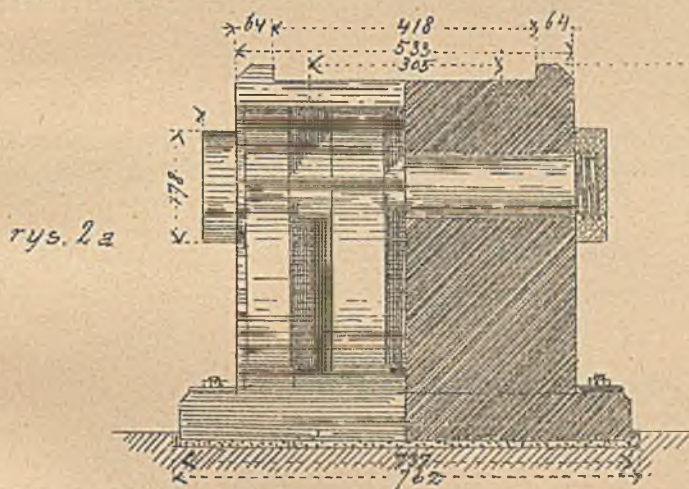
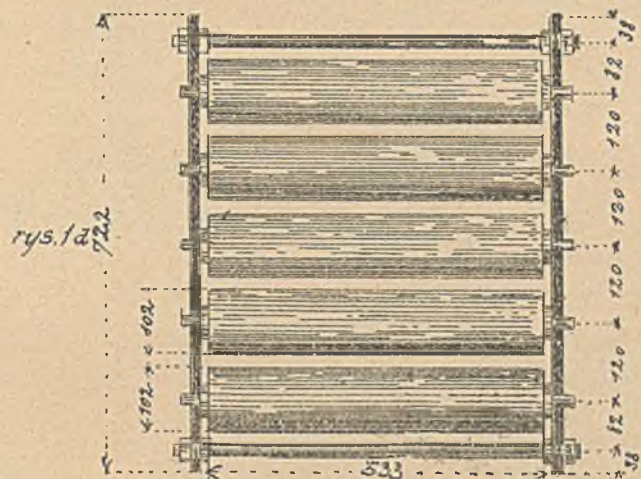
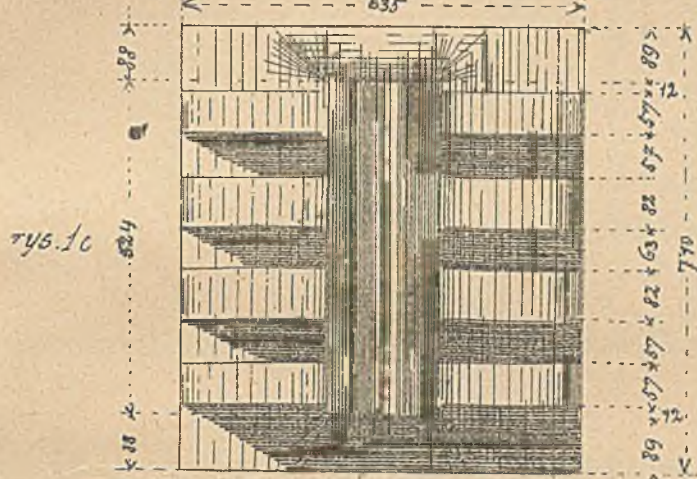
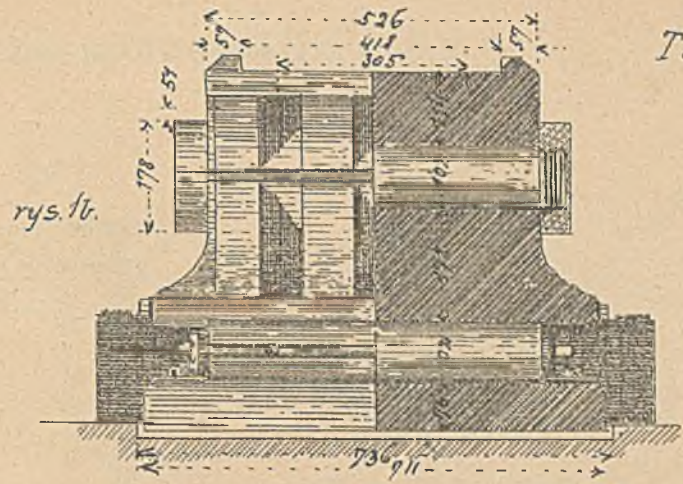
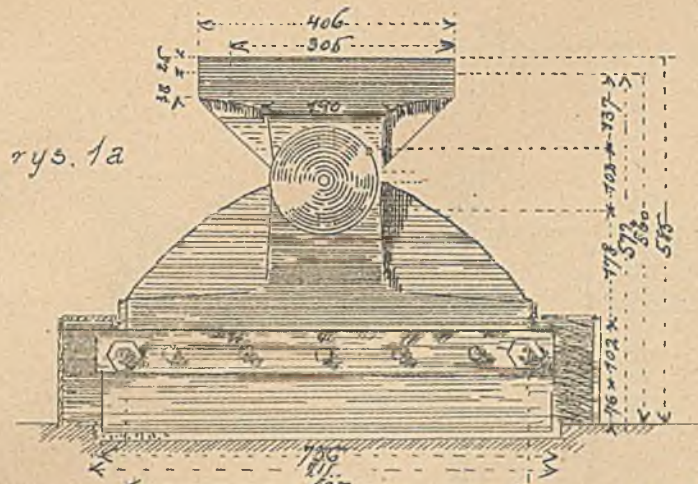

Łozyska mostu kolei
syberyjskiej na Teśmie.

Łozyska

Rys. 1. Most na Delaware w Filadelfii.

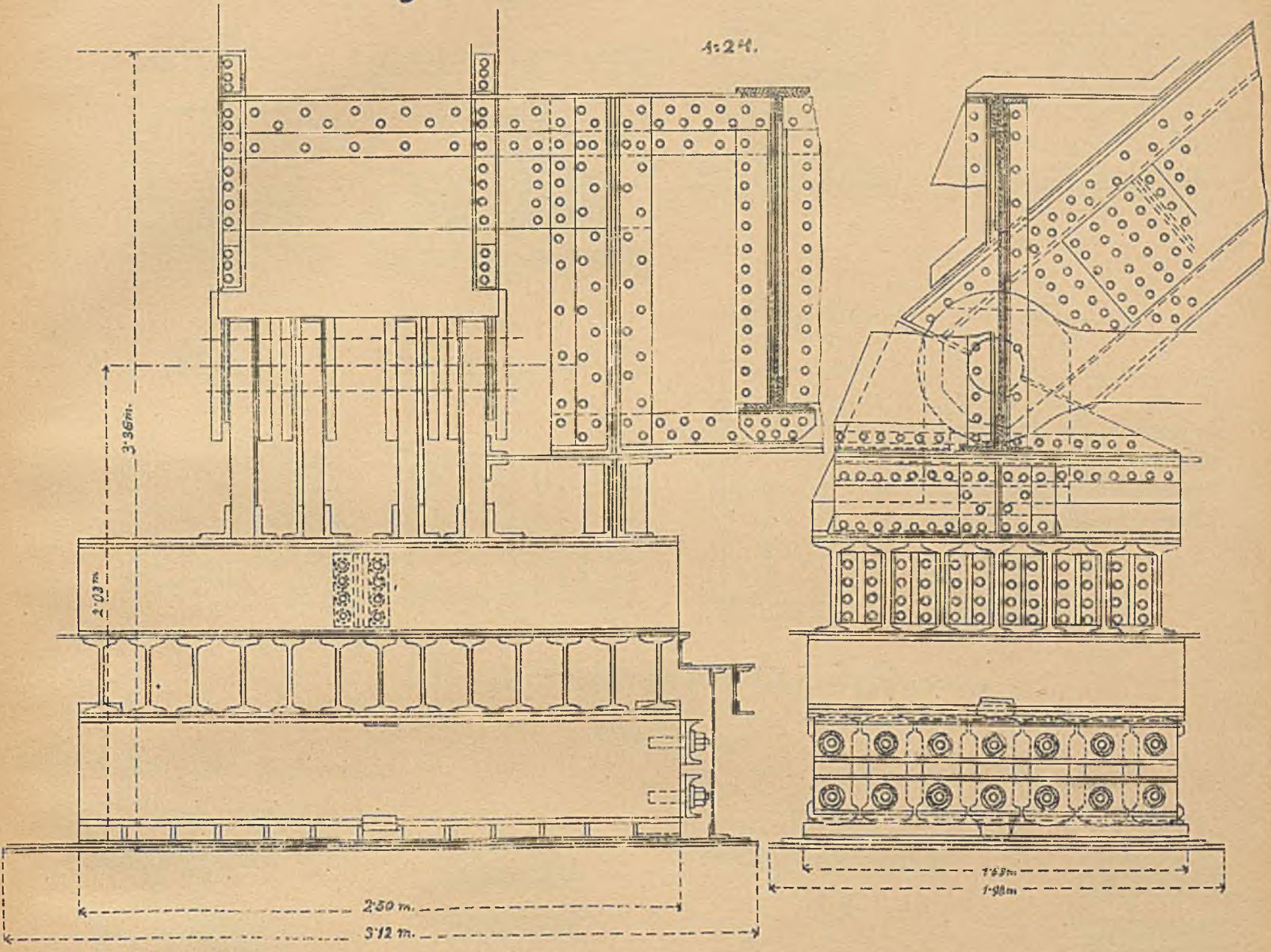

Rys. 2. Mosty na kanale Monachesterskim.

Na filarze

Na przyczółku

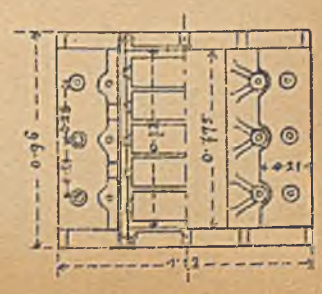
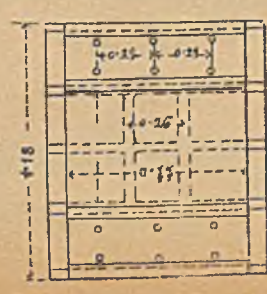
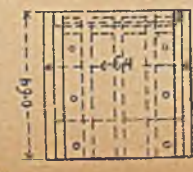
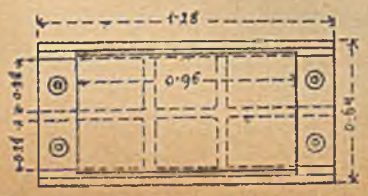
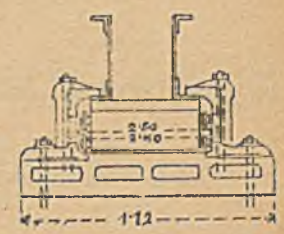
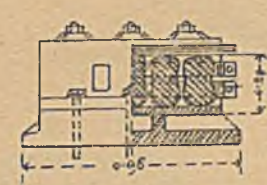
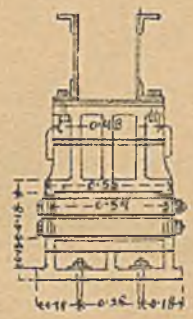
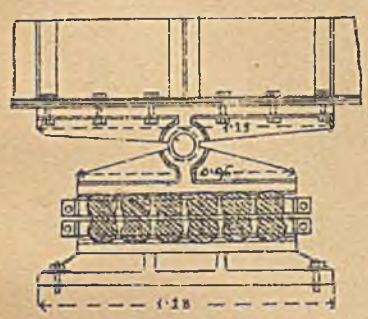

Łożyiska Mostów na kanale Manchesterkim.

Rys. 1.

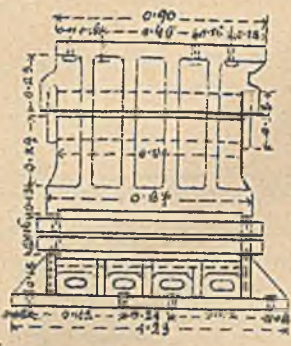

Rys. 2.

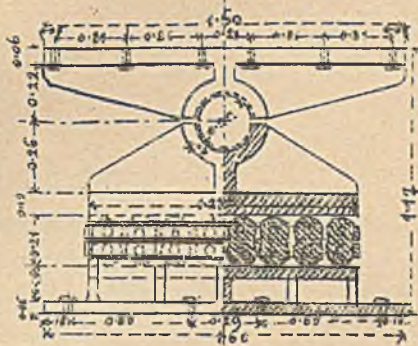

Rys. 3.

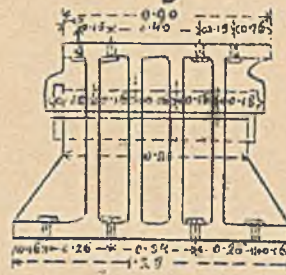

Rys. 4.

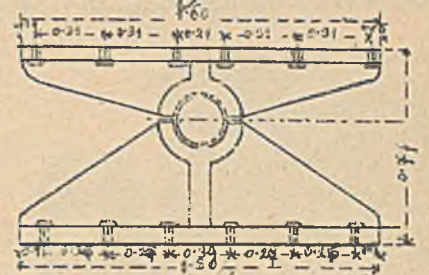

Rys. 1a

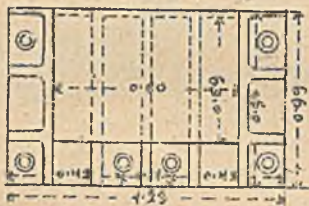

Rys. 1b



Rys. 3a

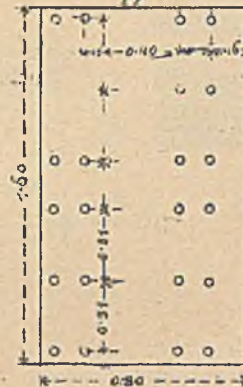

Rys. 4a

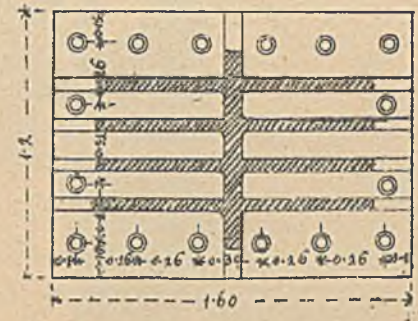

Most Stefani w Wiedniu.

Rys. 5. Łożyśkaruchome.

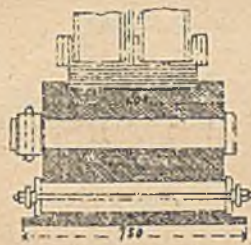
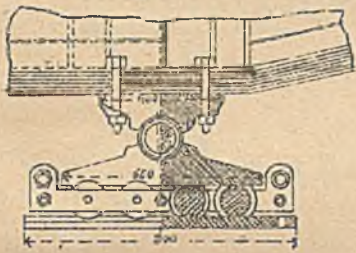

Rys. 6. Łożyśka stałe.

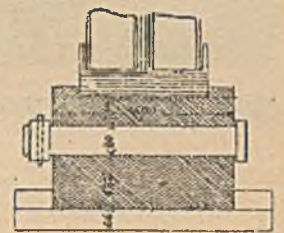
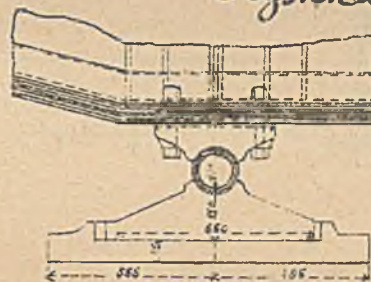

Rys. 7. Most na Iraxie pod Plattling.

1:20

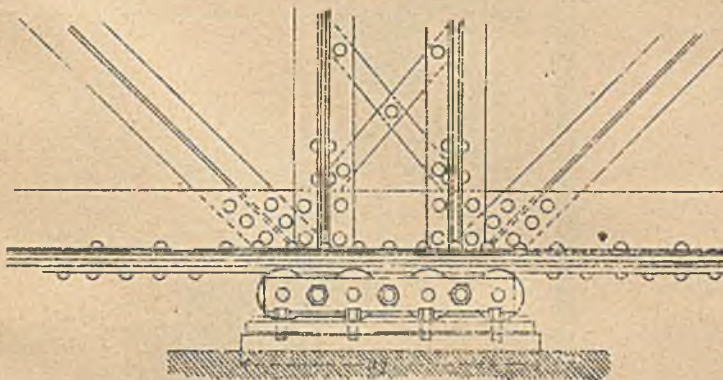

Rys. 7a.



Rys. 7b.

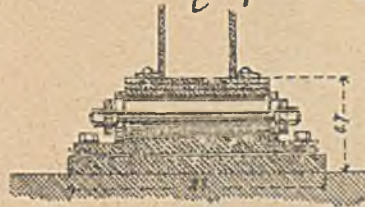

Rys. 8a

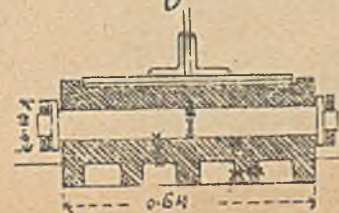

Rys. 8. Most Waverley w

Edynburgu.

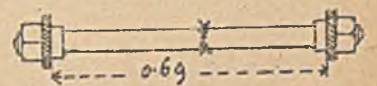

Rys. 8b.

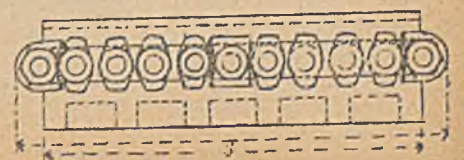

Łozyska

Mostów kolei Badeniskiej Odenwaldzkiej.

Rys. 1. Łozysko stałe.

Rys. 1a. Łozysko ruchome.

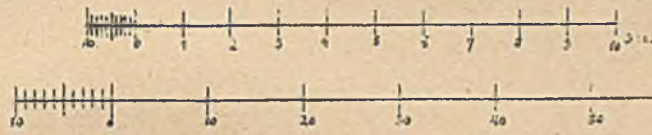
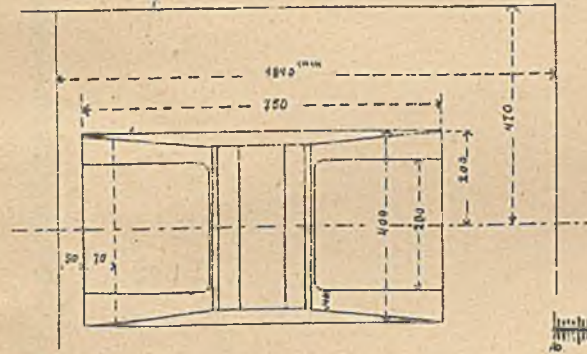
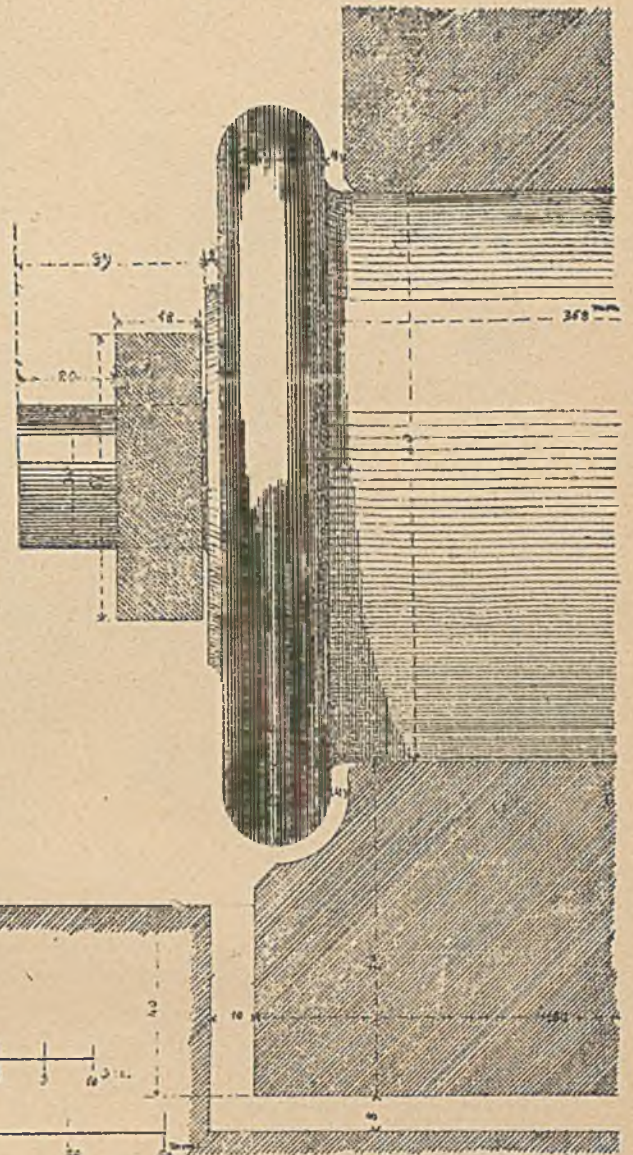
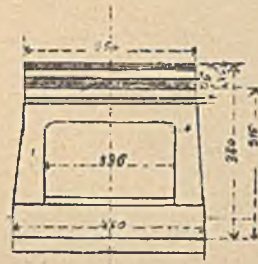
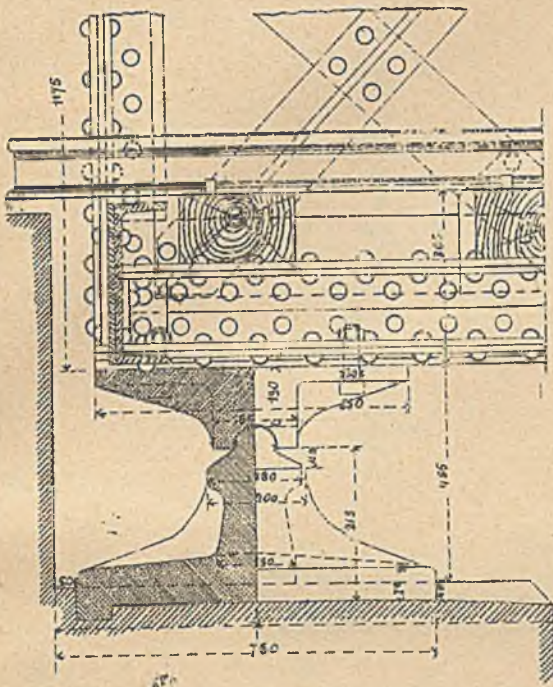

Rys. 1b.

Rys. 1c.

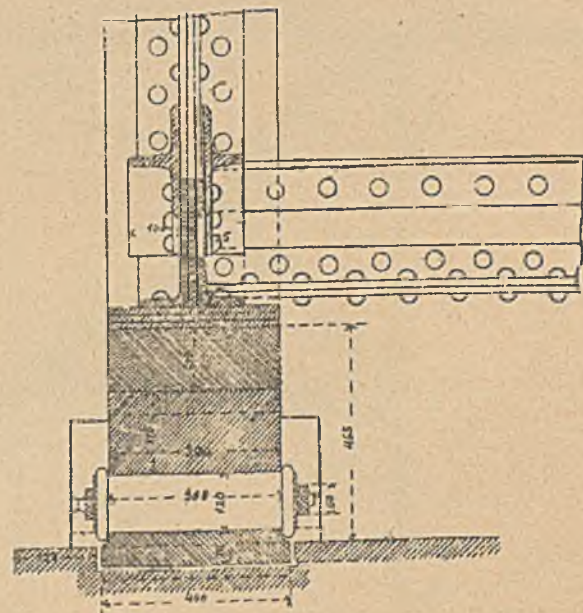
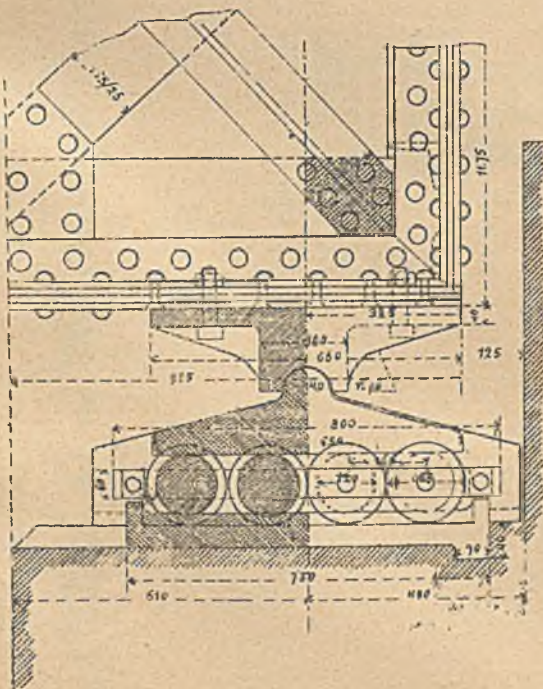

Wzrostki poprzeczny mostu.

Rys. 1. Wiadukt na 'Wielkimie pod Czerwą.

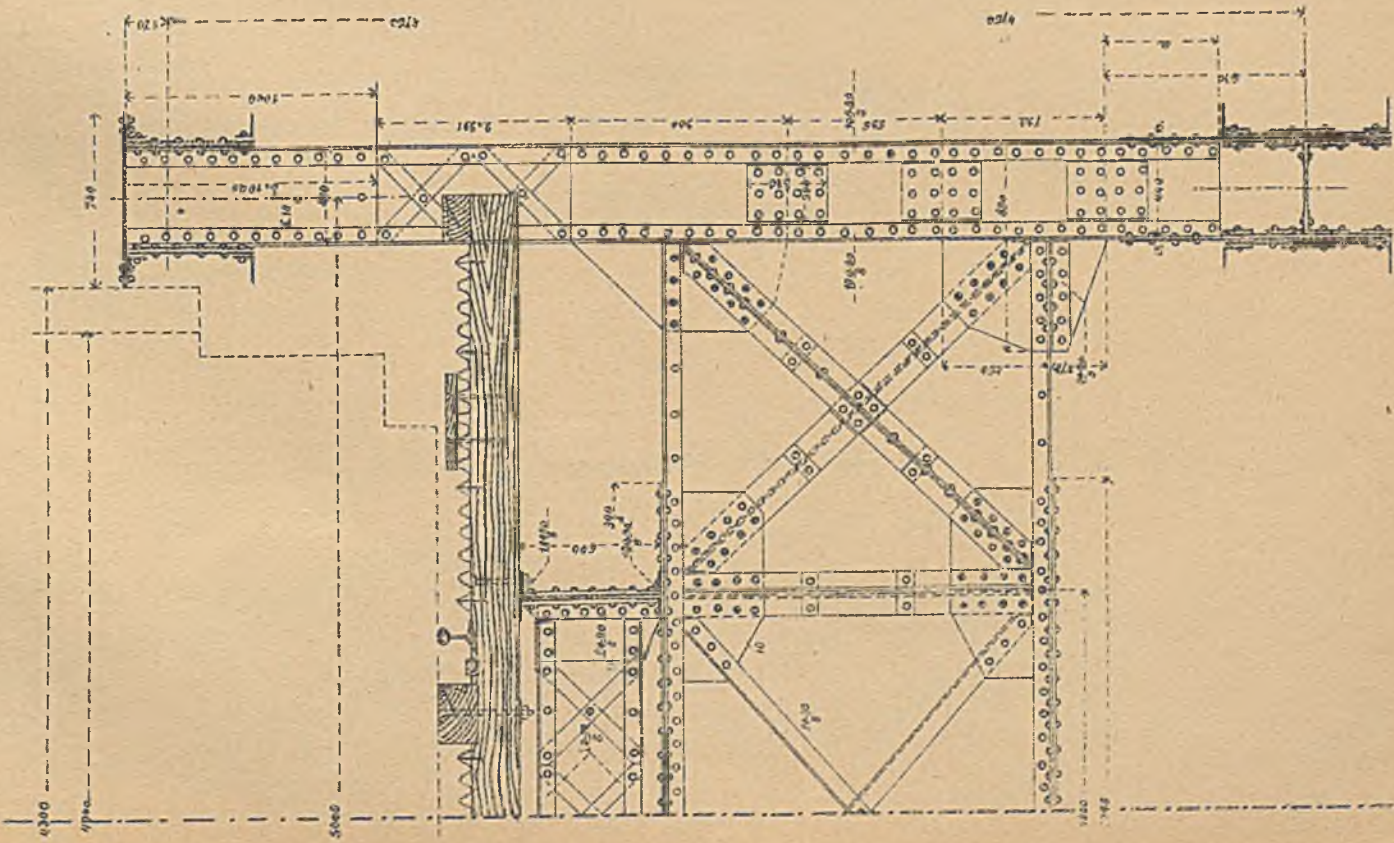

Rys. 2. Most na Sabie w Jaromierzu.

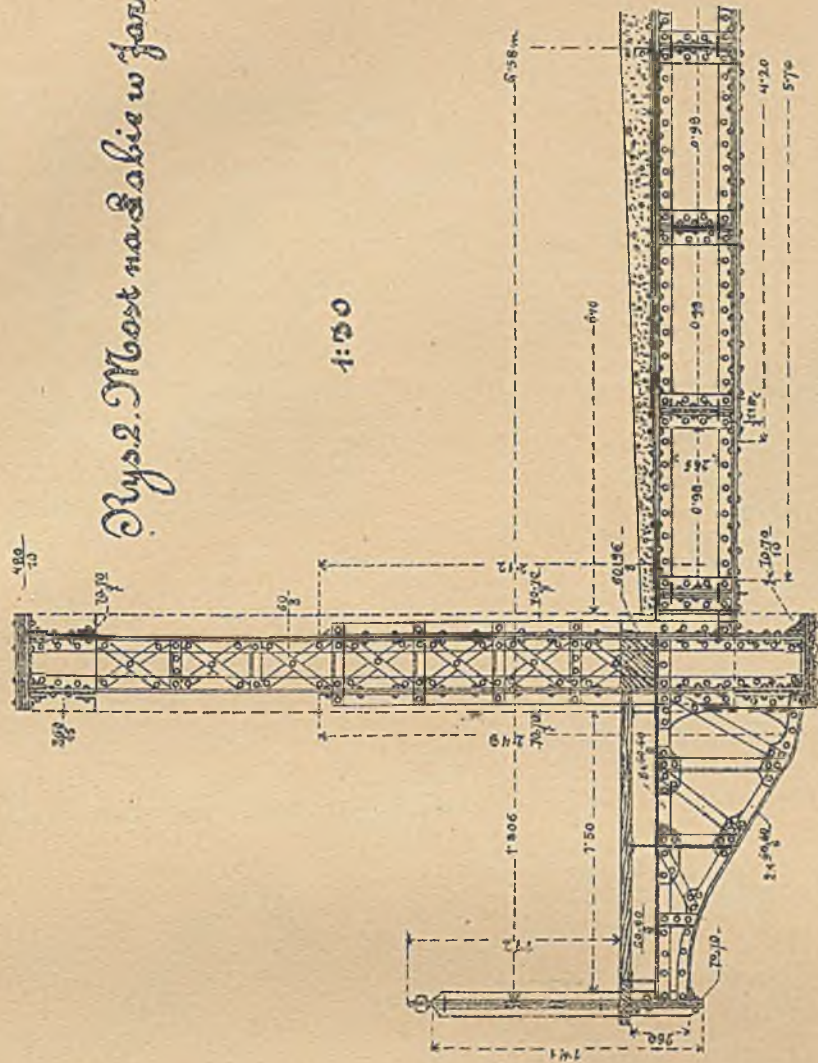

Rys. 3. Most na Neronie w Sremie.

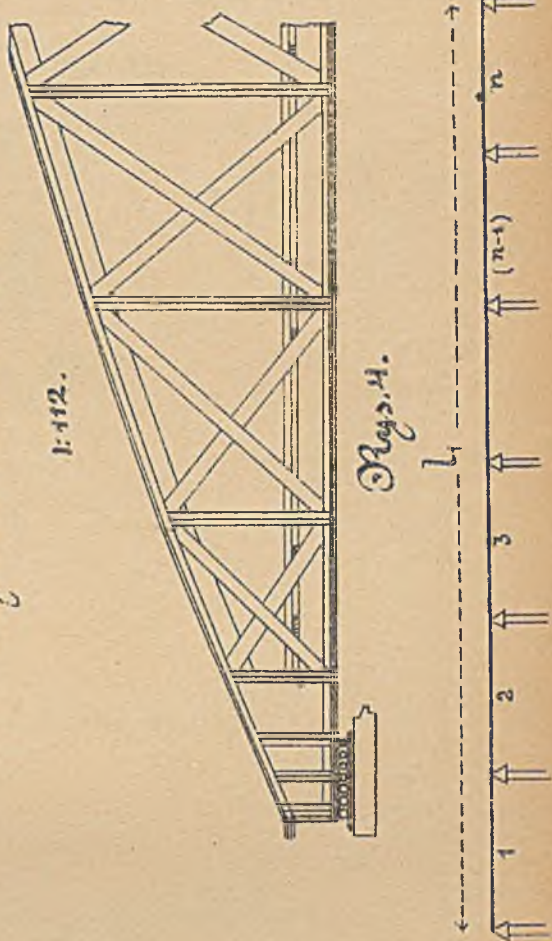

Rys. 4.

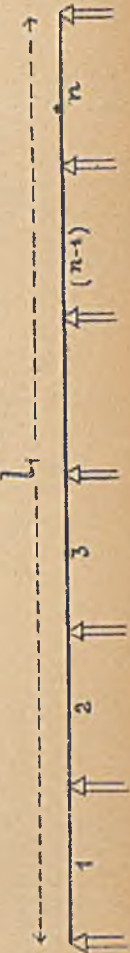

Rys. 1-4

Rys. 1. Most na Dworcu w Gressen

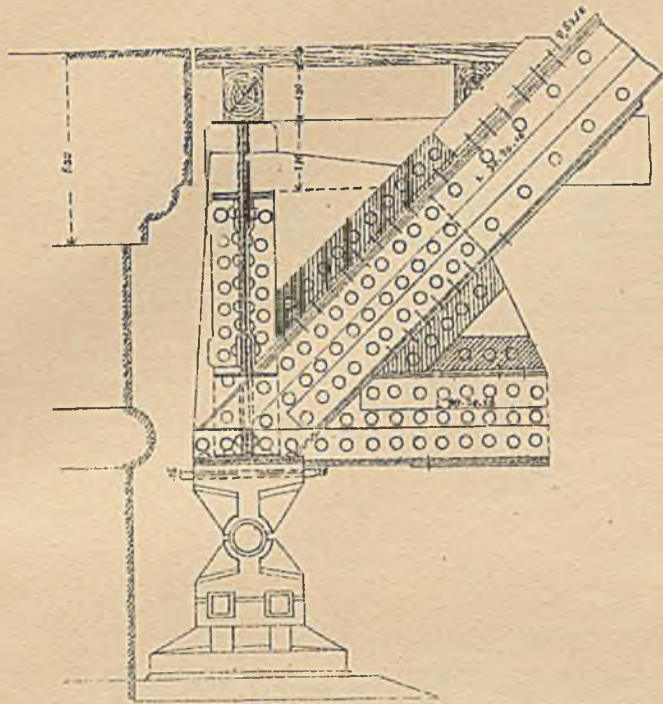

Rys. 2. Most na Werre w Falderre (Neumünster.)

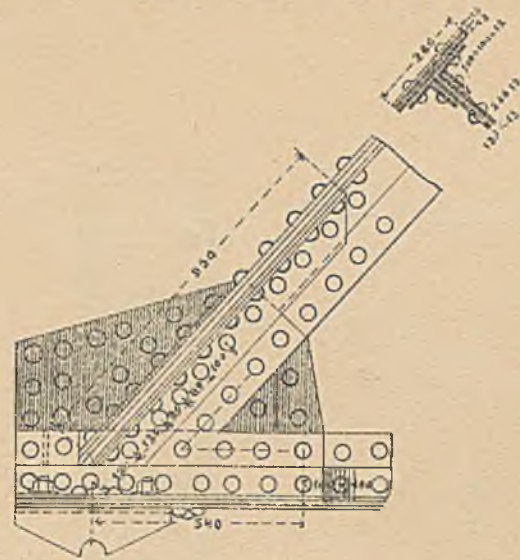

Rys. 3. Podjazd na Dworcu w Erfurcie

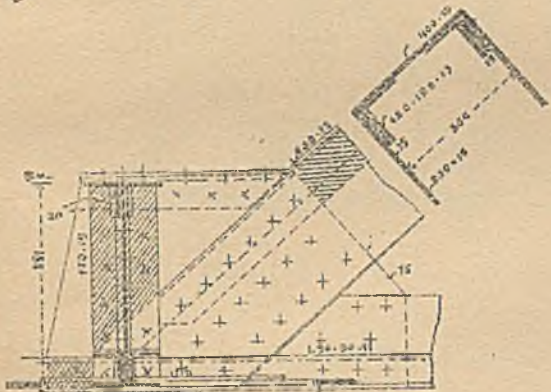

Rys. 3a.

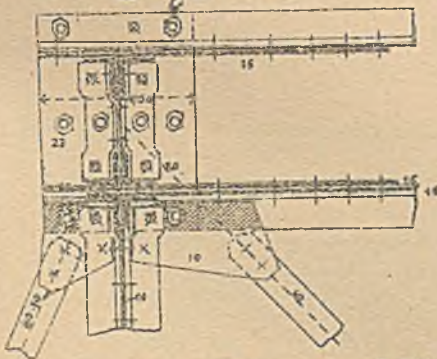

Rys. 4. Wiadukt w Lenggenfeld.

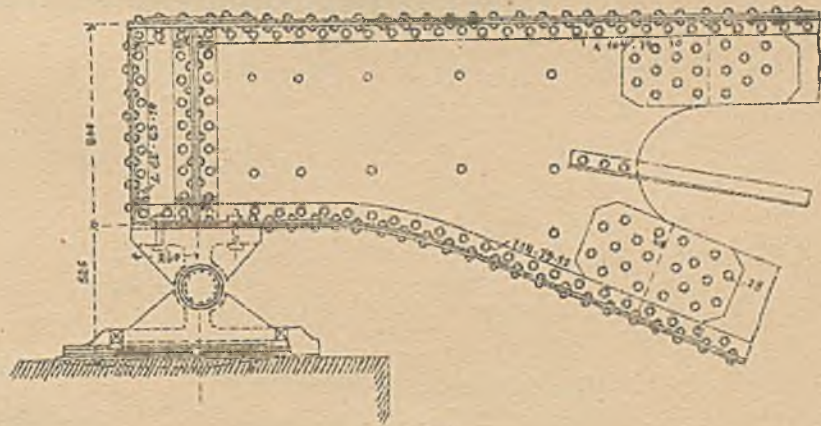

Rys. 5. Most na Darnie pod Bruck.

1:40

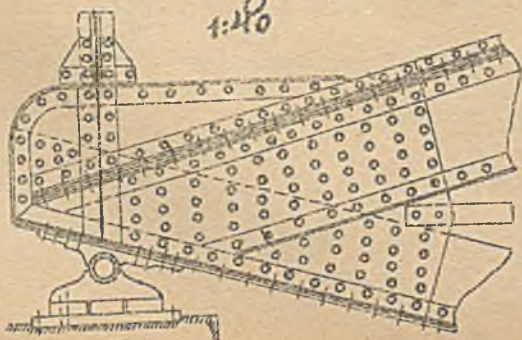

1:30

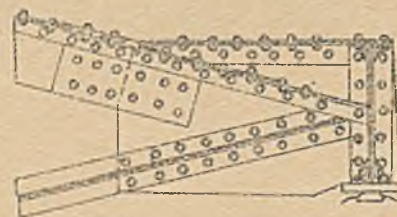

Rys. 5b.

rys. 1.

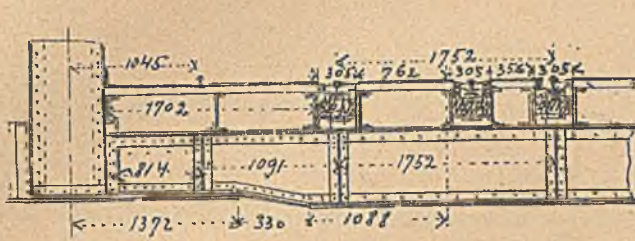

rys. 2.

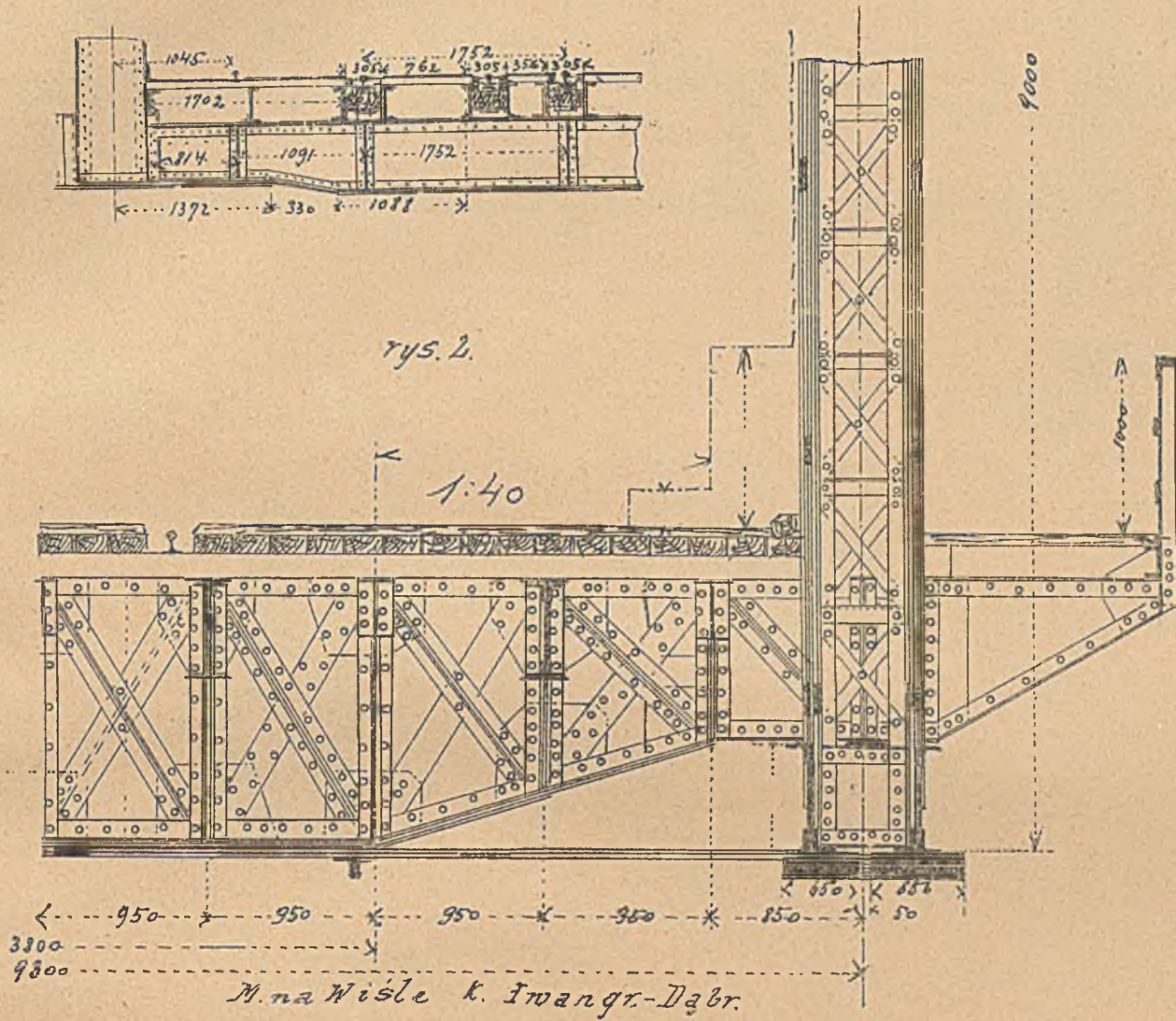

rys. 3.

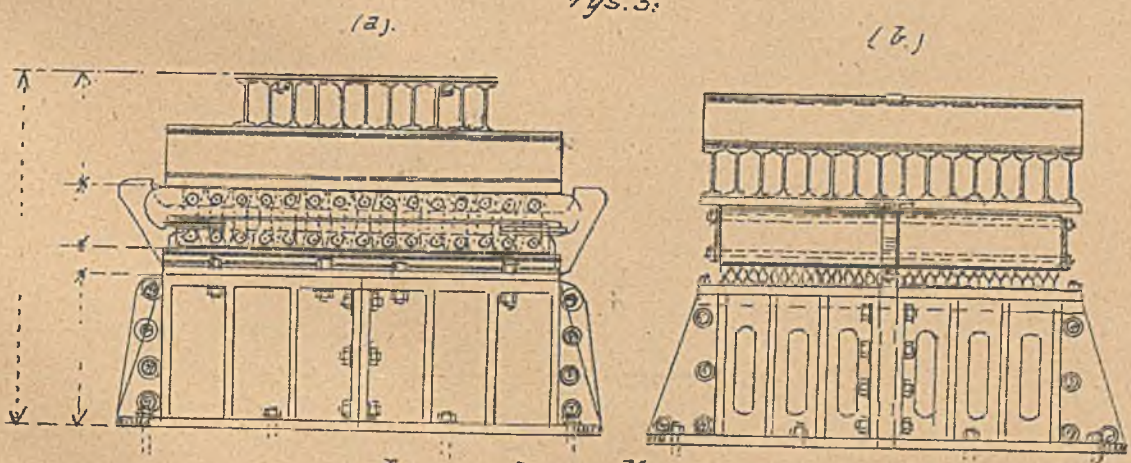

Łozysko Morisona.

E. W.

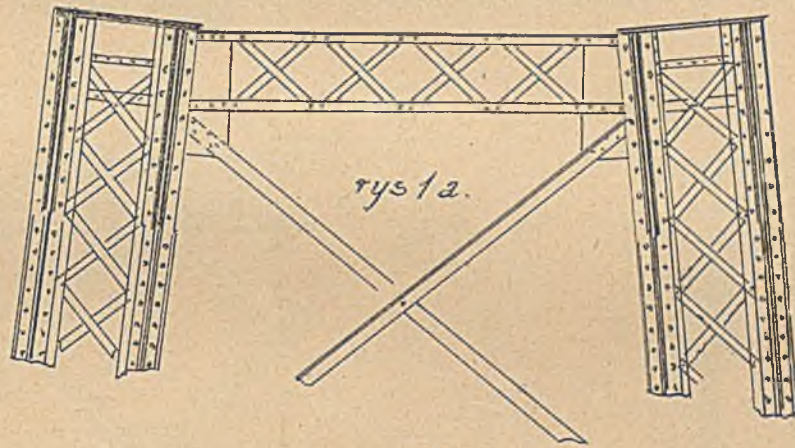
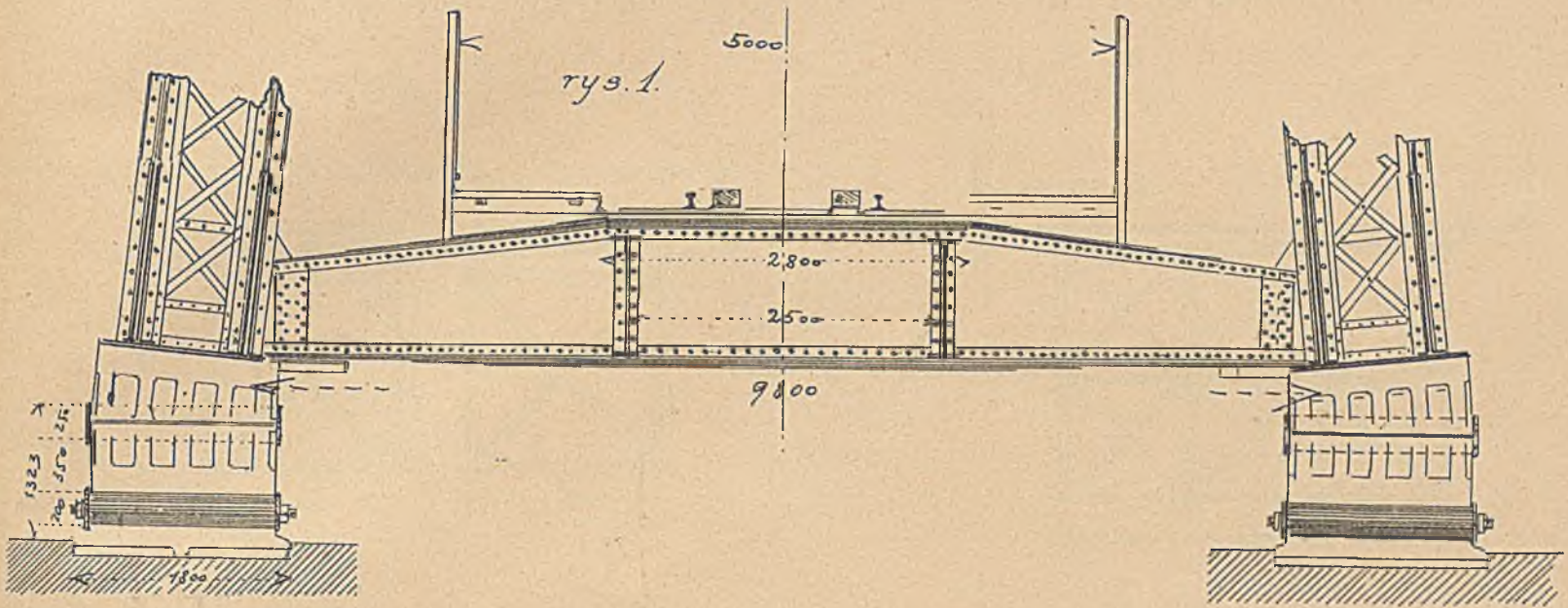

rys. 1b.

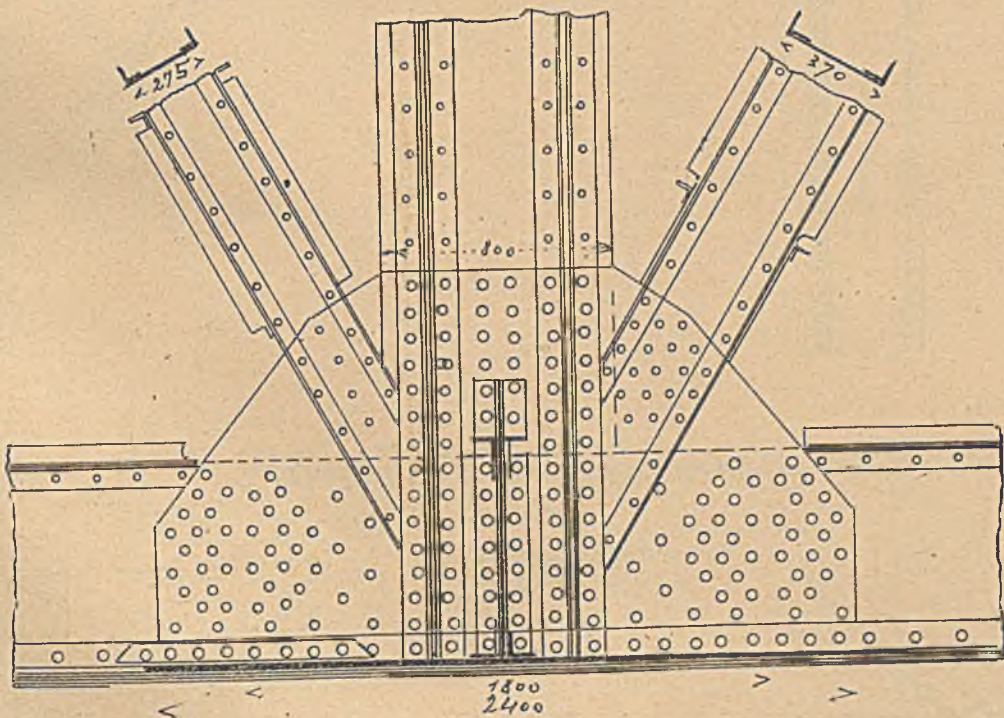

E. W.

Przekrój poprzeczny.

Rys. 1a, 1b. Rozkład i ilość belek głównych.

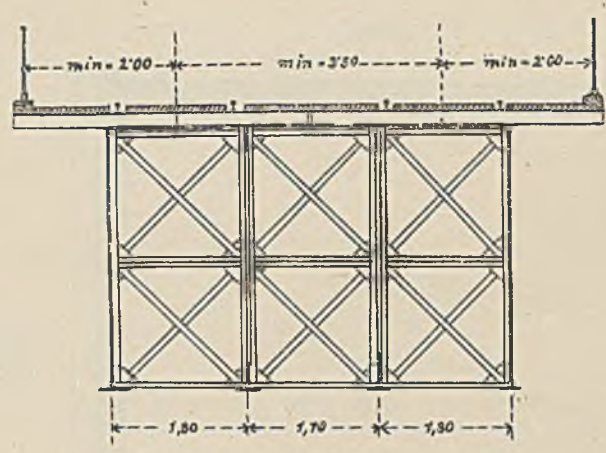
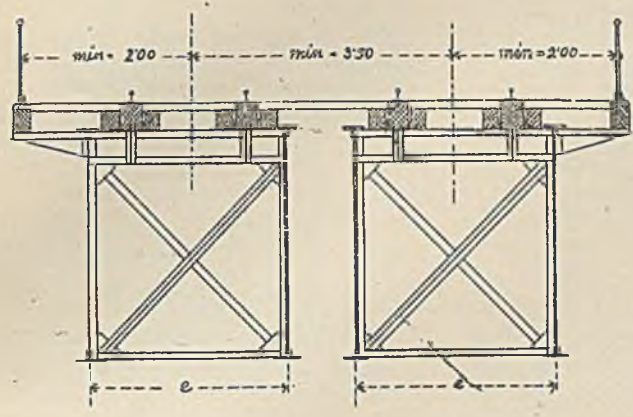

Rys. 2a, 2b. Most na Dnieprze pod Kresucą.

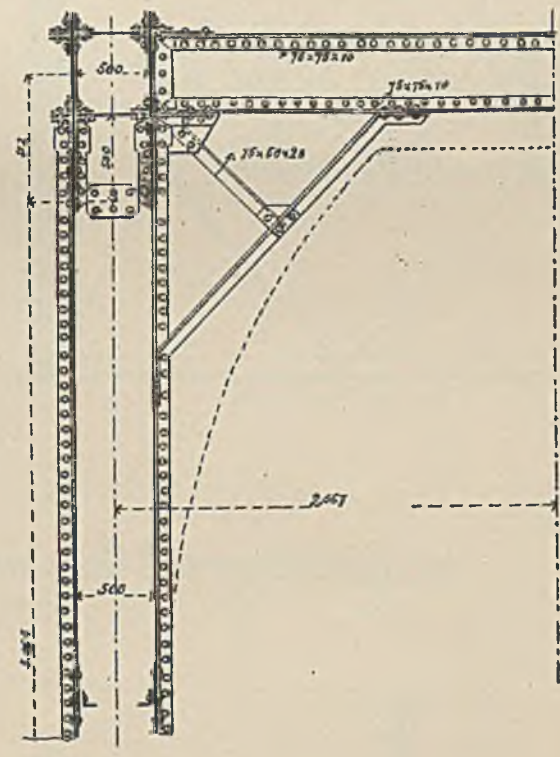
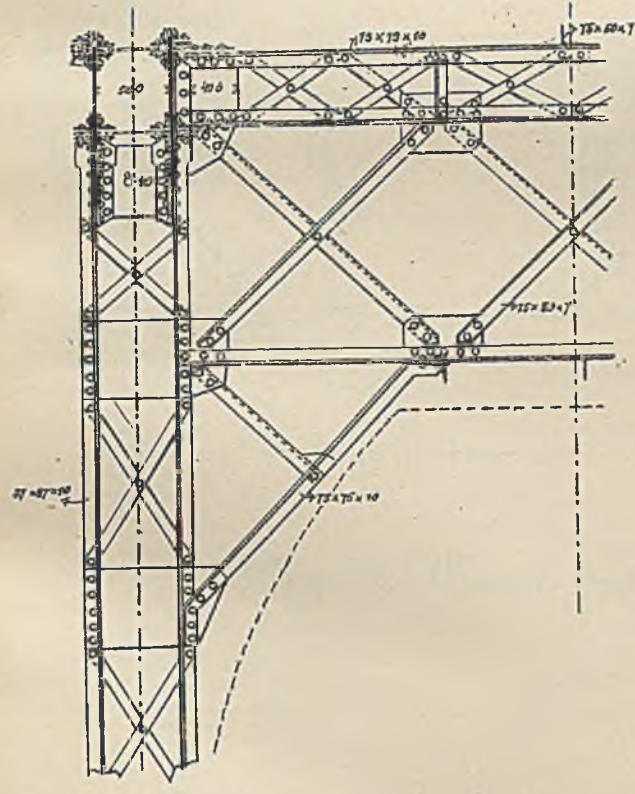

Rys. 3a, 3b. Łożyska mostku na Górbach w Szwajcaryi.

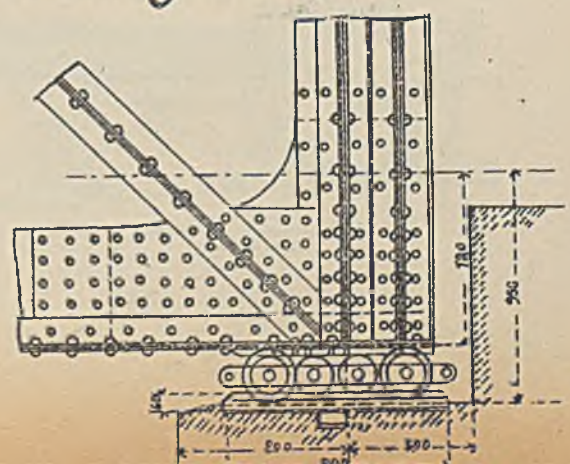
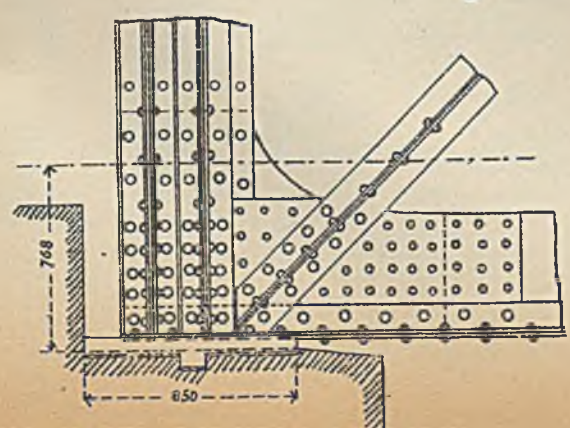

Handwritten signature or initials in the bottom right corner.

Łozyska i przekrój poprzeczny mostu.

Rys. 1. Most Św. Jana w Ischlu.

Łozysko ruchome

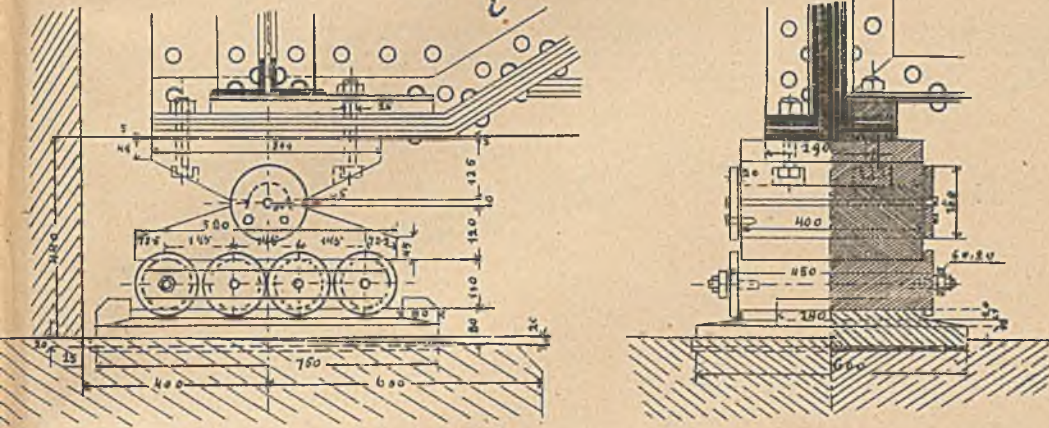

Rys. 3. Most na Moreli pod Elber.

1:100

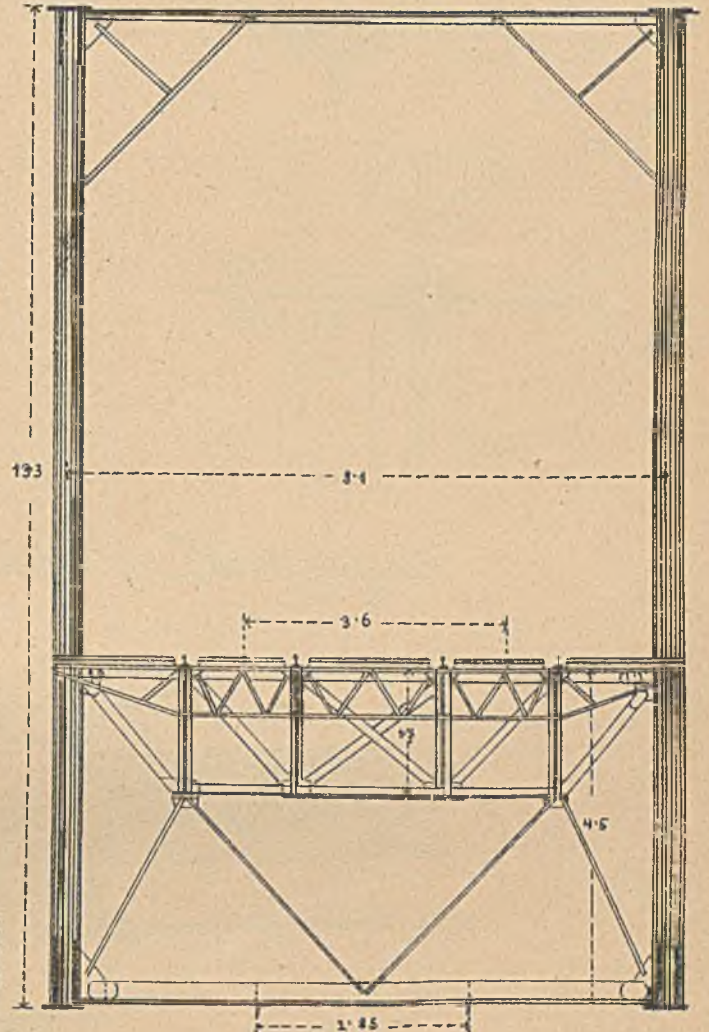

Rys. 2. Łozysko stałe.

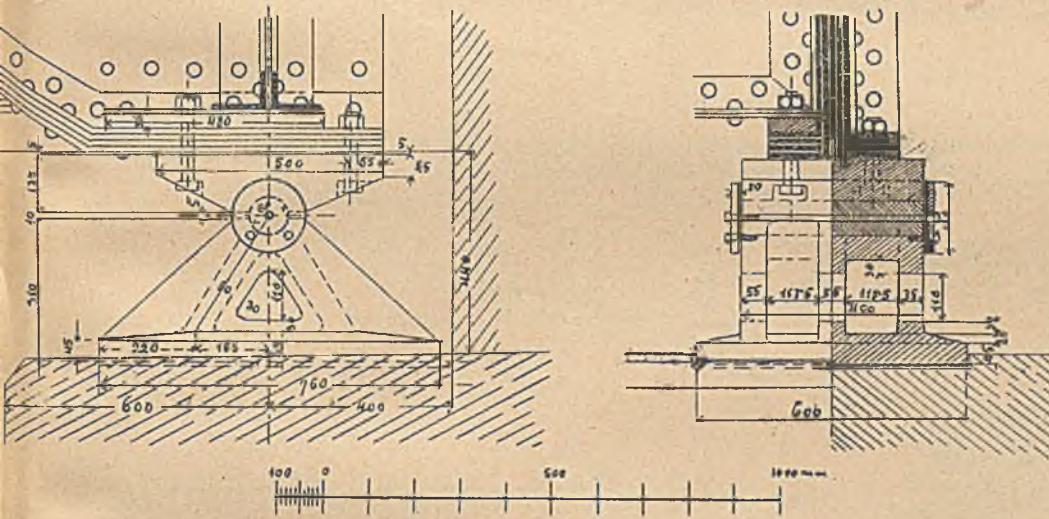

Rys. 4. Most drogowy na Argen pod Langenargen.

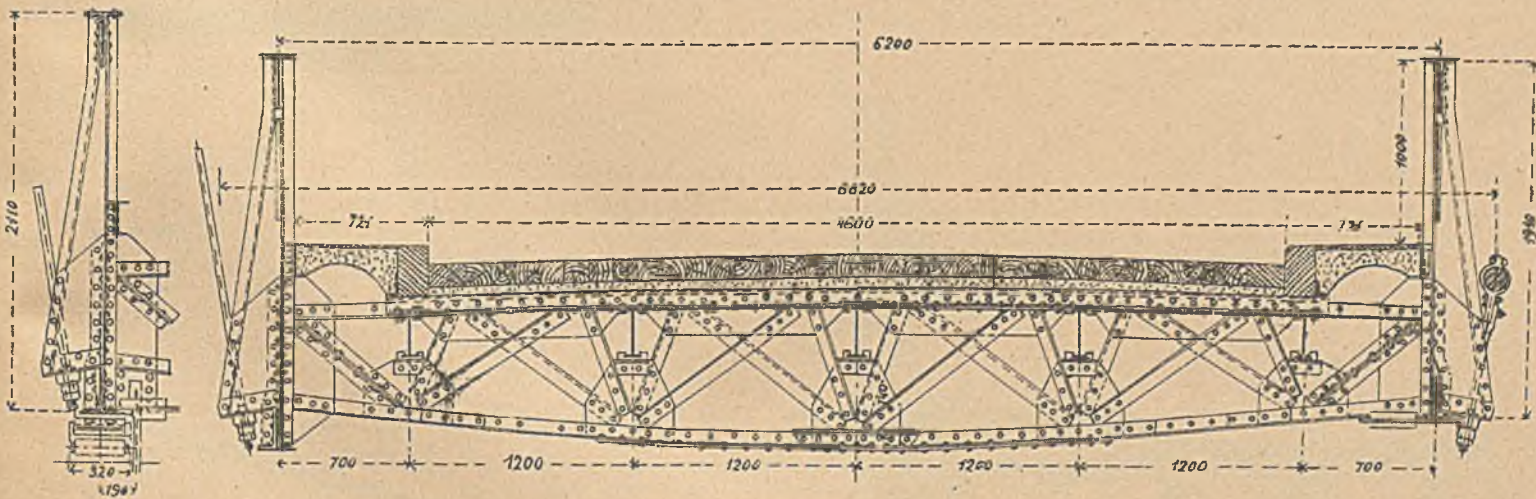

Ky. J. 2

Rys. 1. Most na Saali w Bernburgu

1:25

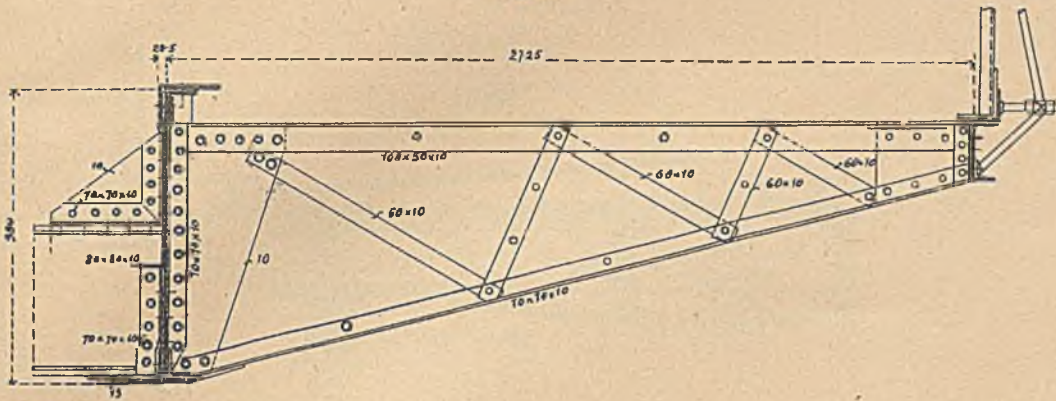

Rys. 2. Most kolei Baden-
skiej nad doliną Gutors

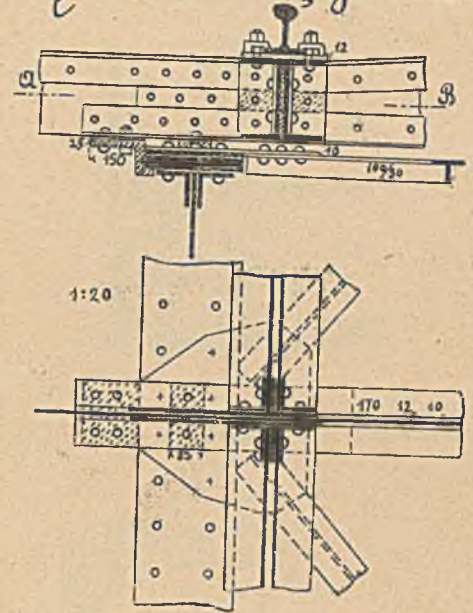

Rys. 3. Most na Saali w Bernburgu.

1:25

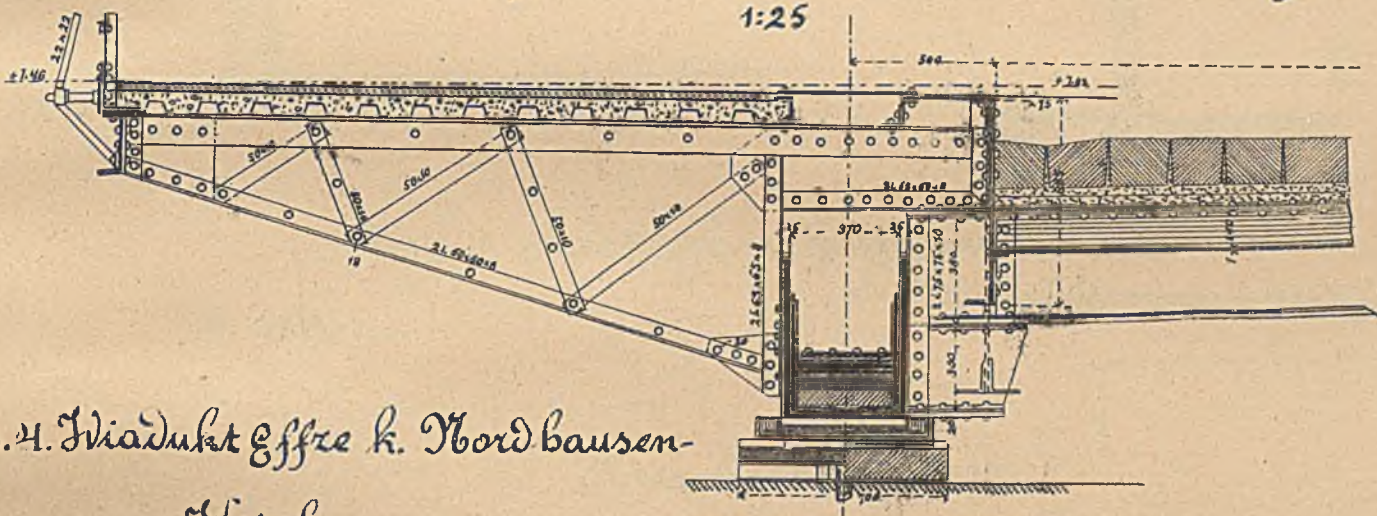

Rys. 4. Wiadukt gffze k. Nordhausen-

Wetzlar.

1:50

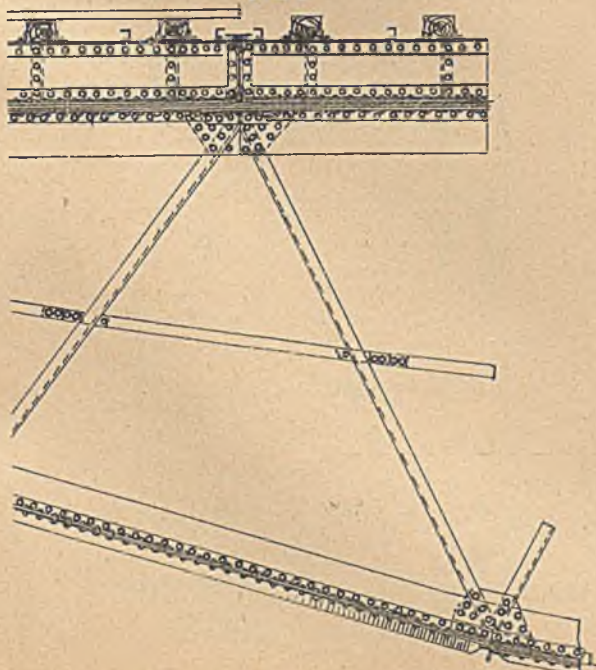

Rys. 5. Most na Obrzy w Łatcu

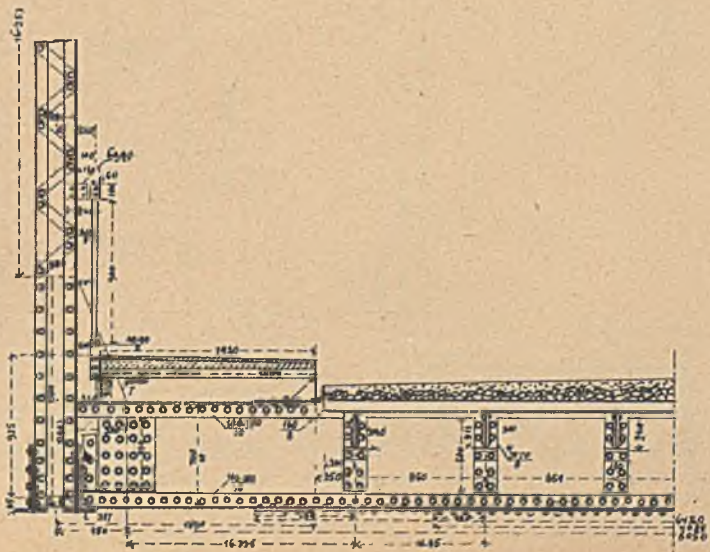

Rys. 1. 2.

Łączenie poprzeczne i belki główne.

Rys. 1. Wiadukt Lengenfeld k. Nordhausen-
Wetzlar.
1:50

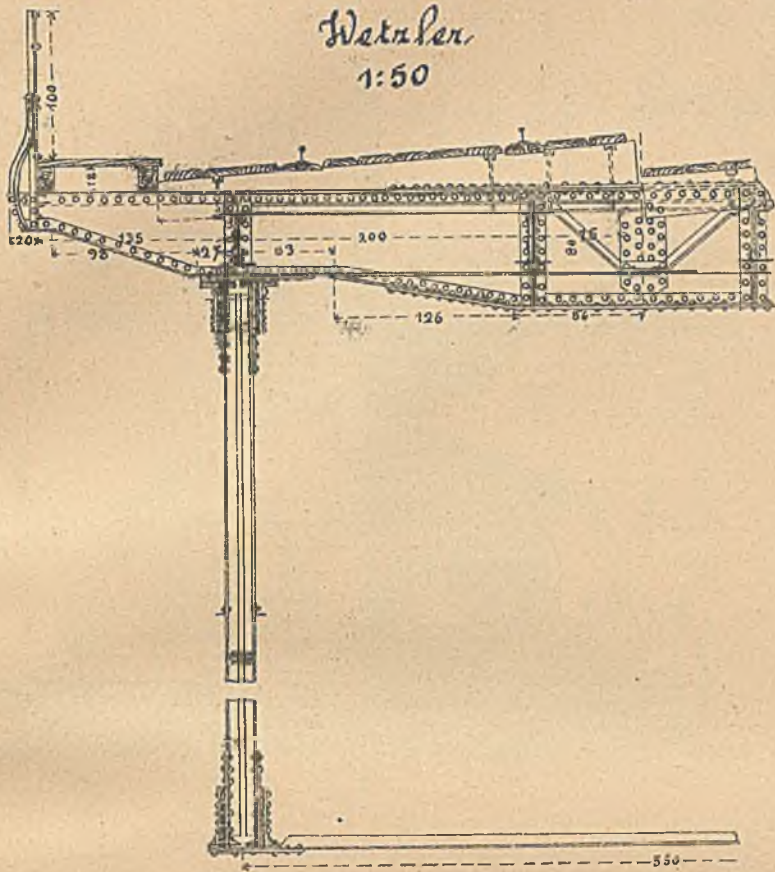

Rys. 2. Most na Dunaju p.
Czernewoda

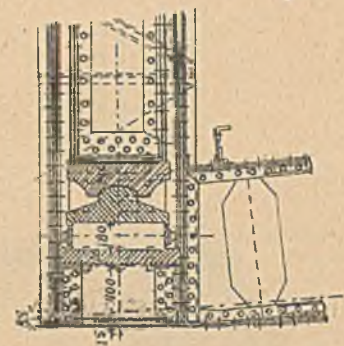

Rys. 3. Most na Saaxi w Bernburgu

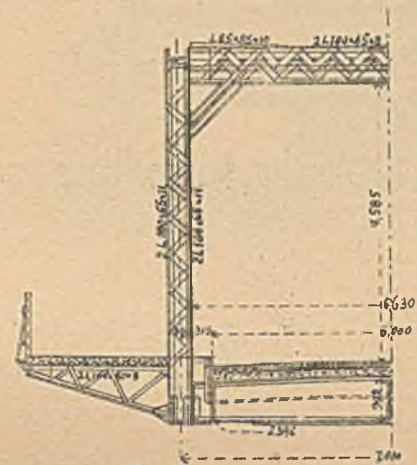

Rys. 4. Szerokoje wolnego przejazdu
K. główna
K. wąskotorowa s=0.76 z jądrem na podwoziach

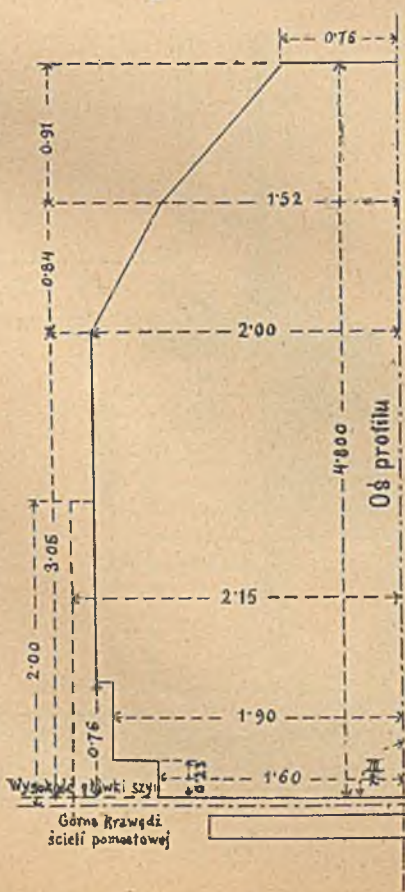

K. wąskotorowa s=0.76

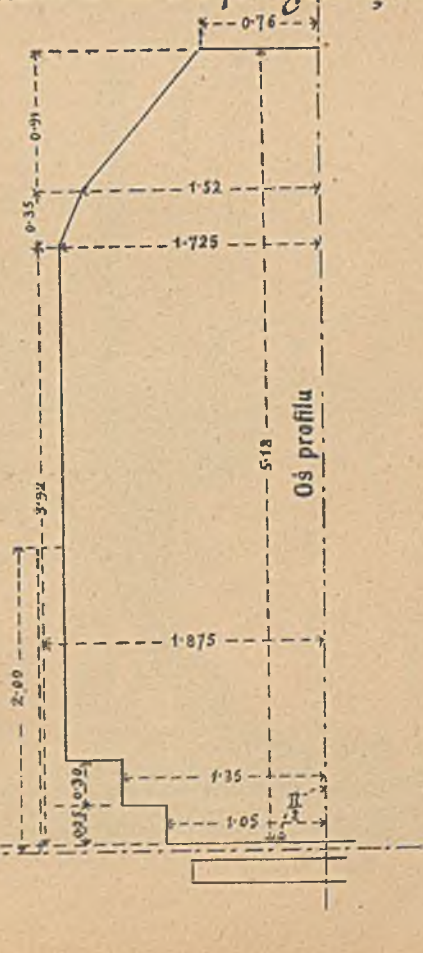
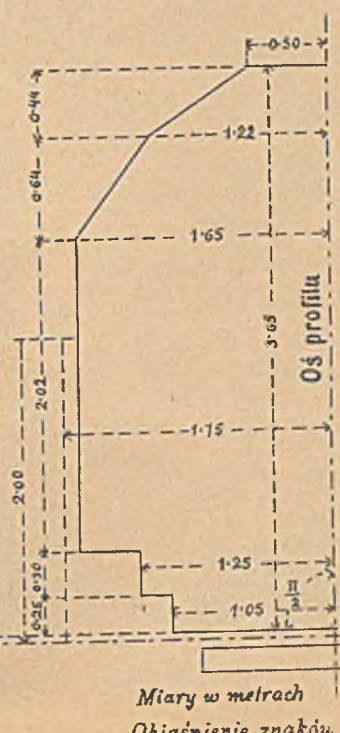

Dr. M. S. Bullis. M. Krat.

Linia ograniczająca profil wolnego przejazdu.
Granica poziomo lub skośnie w kierunku do
równoległej osi mostów.

mostu krawędzi pasów, zastrzałów i stupków

Rys. 4. S.

Łozyska kołyskowe
 mostu na młynówce Morawy
 w Hodoninie

Łozysko ruchome
 Rys. 1.

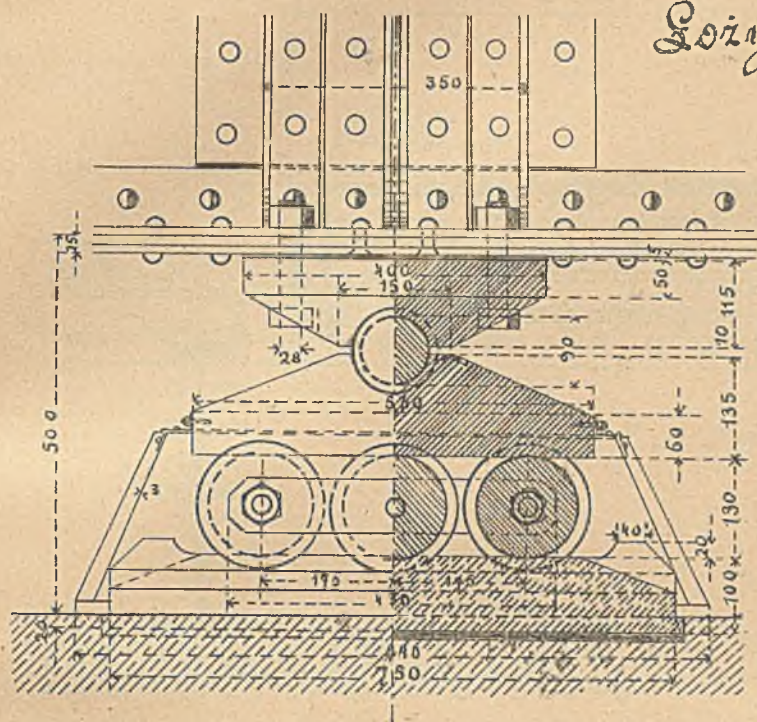

1:10

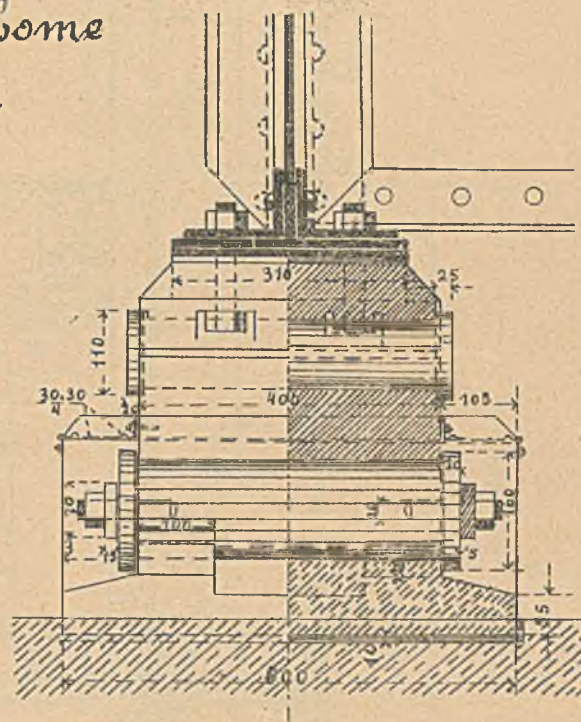

Rys. 2. Łozysko stałe.

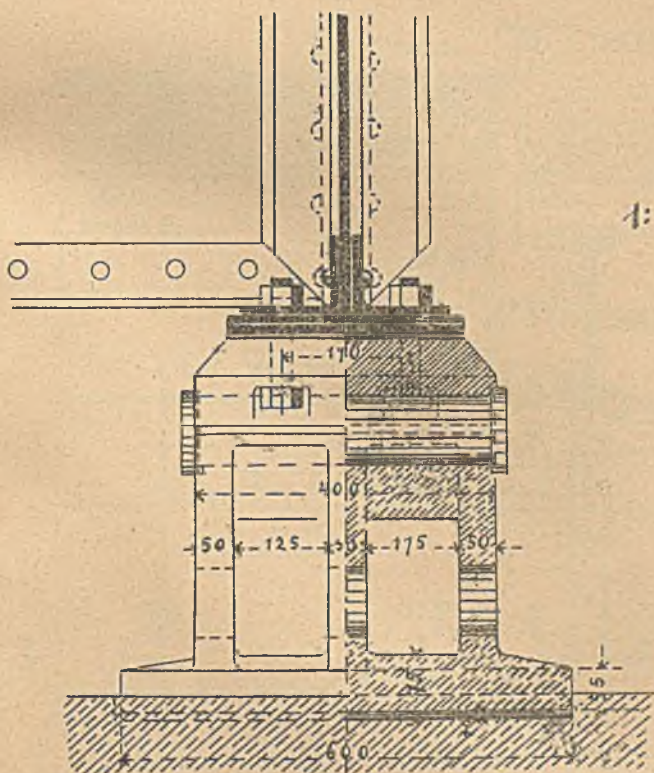

1:10

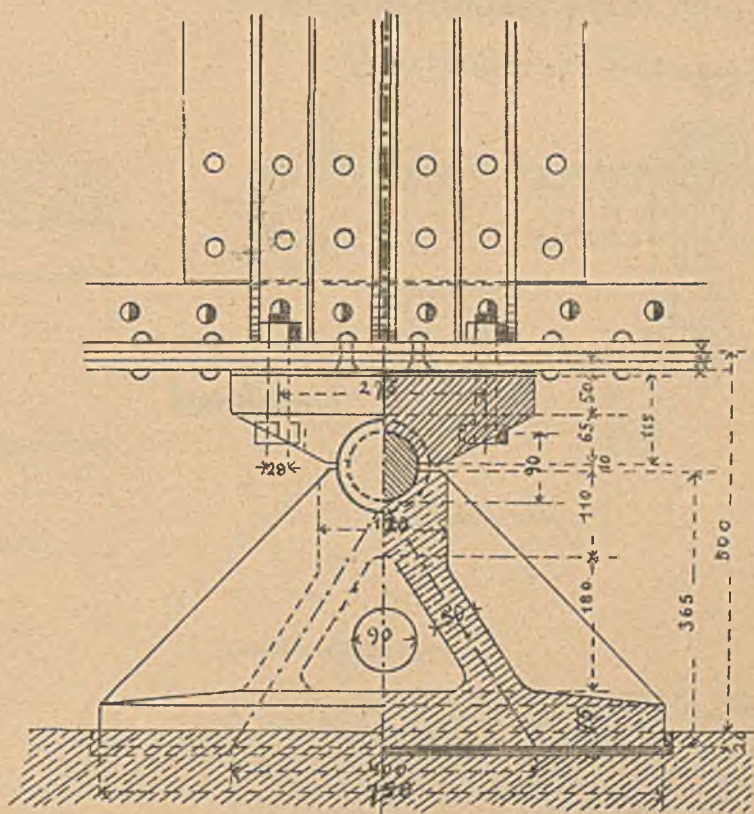

Rys. 1-2

Rys. 1. Most na Zabrach w Oberndorf-
-Laufen.

1:15

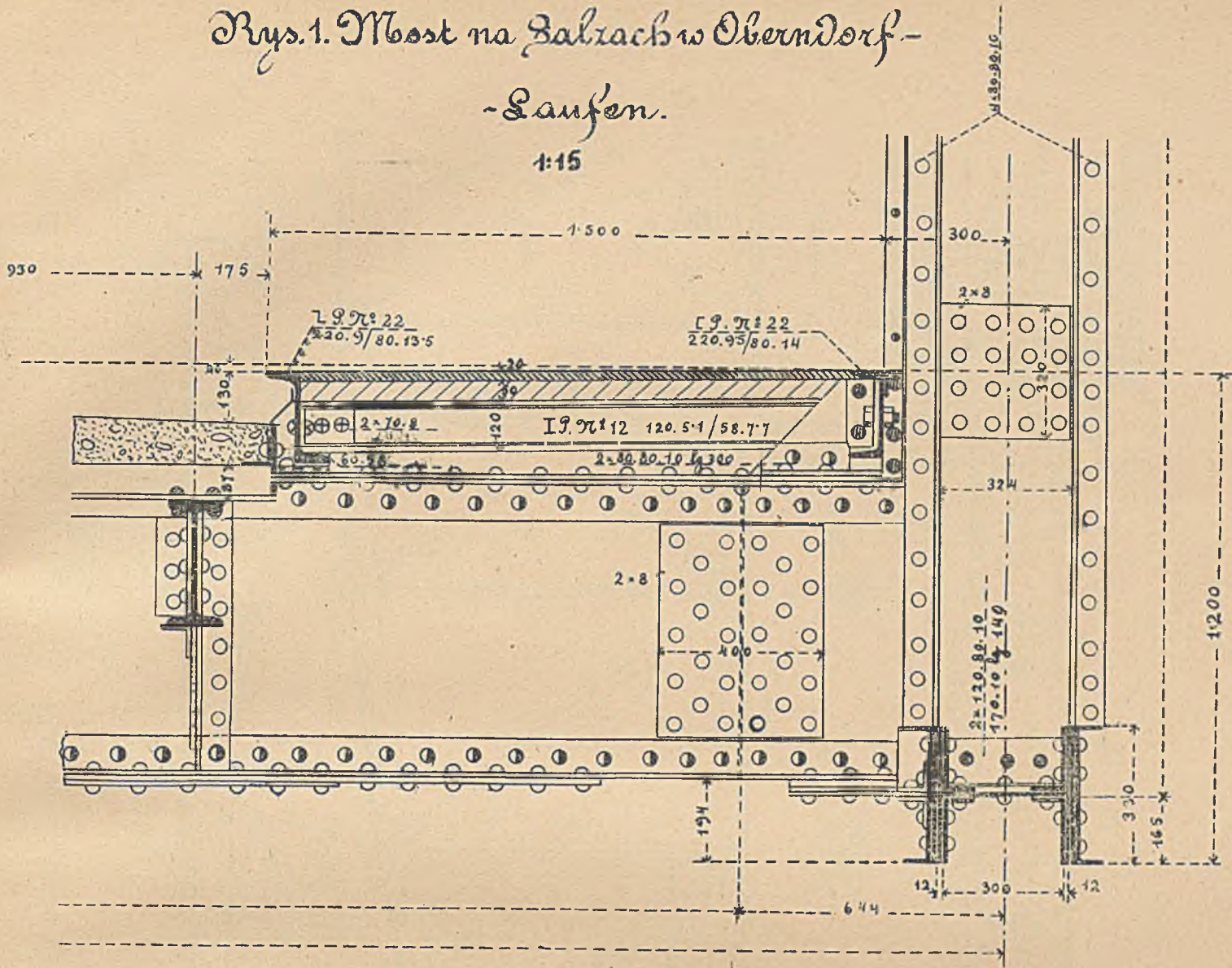

Rys. 2. Most na młynowce w Kadoninie.

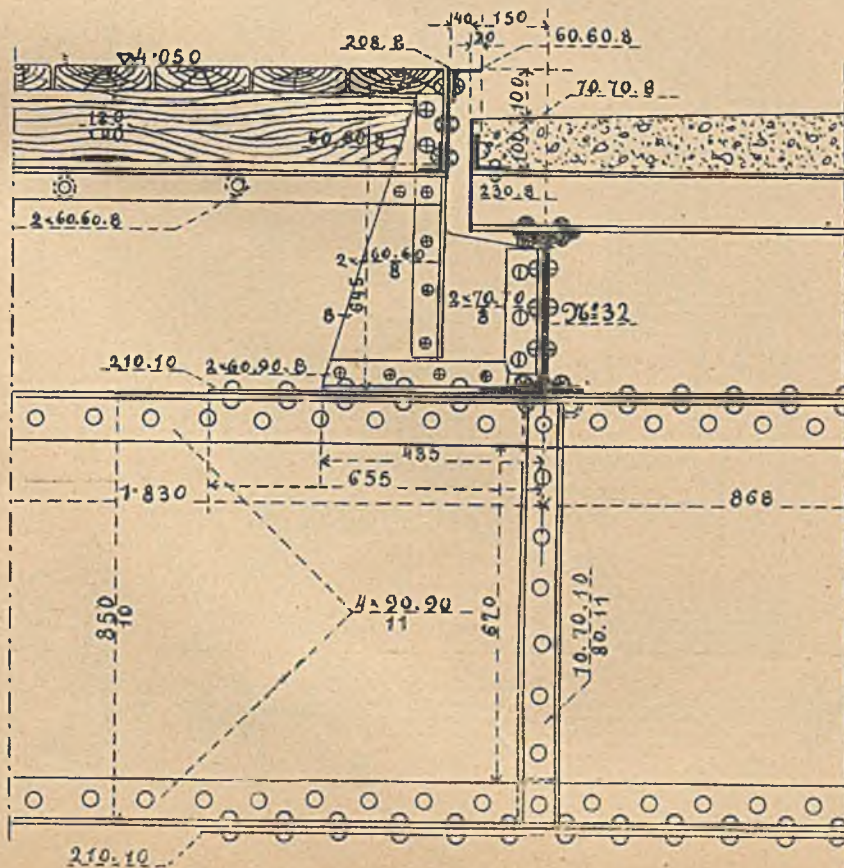

Rys. 3. Wiadukt przez dolinę
Goulenore we Francji.

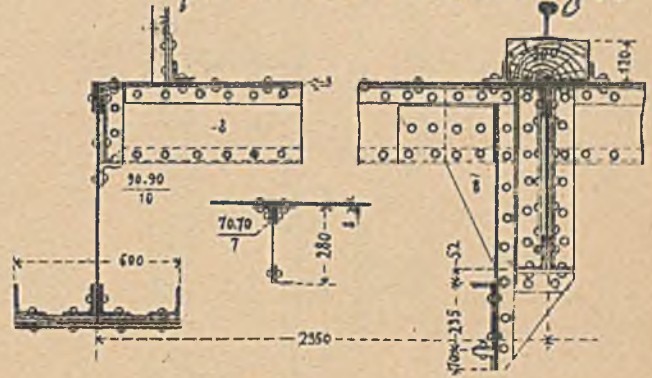

Rys. 3a.

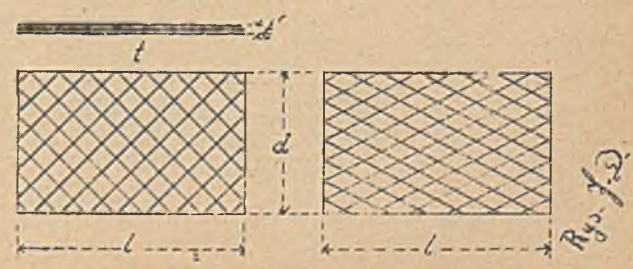

Drogowy most kratowy na Otawie w Strakowicach.

Tabl. 114.

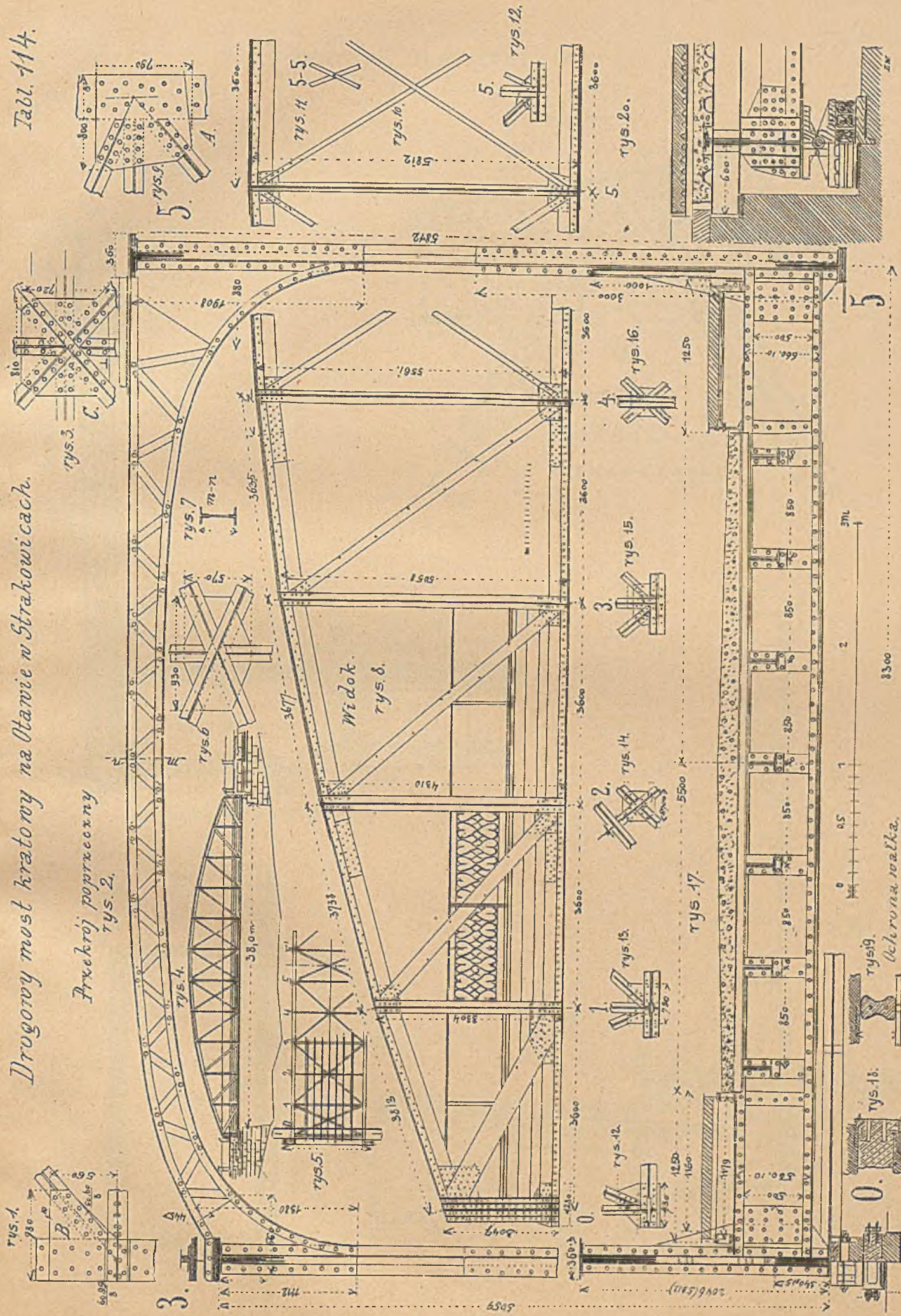

Dr. M. Thullie: Mosty krat. xel.

Przekroje poprzeczne

Tabl. 115.

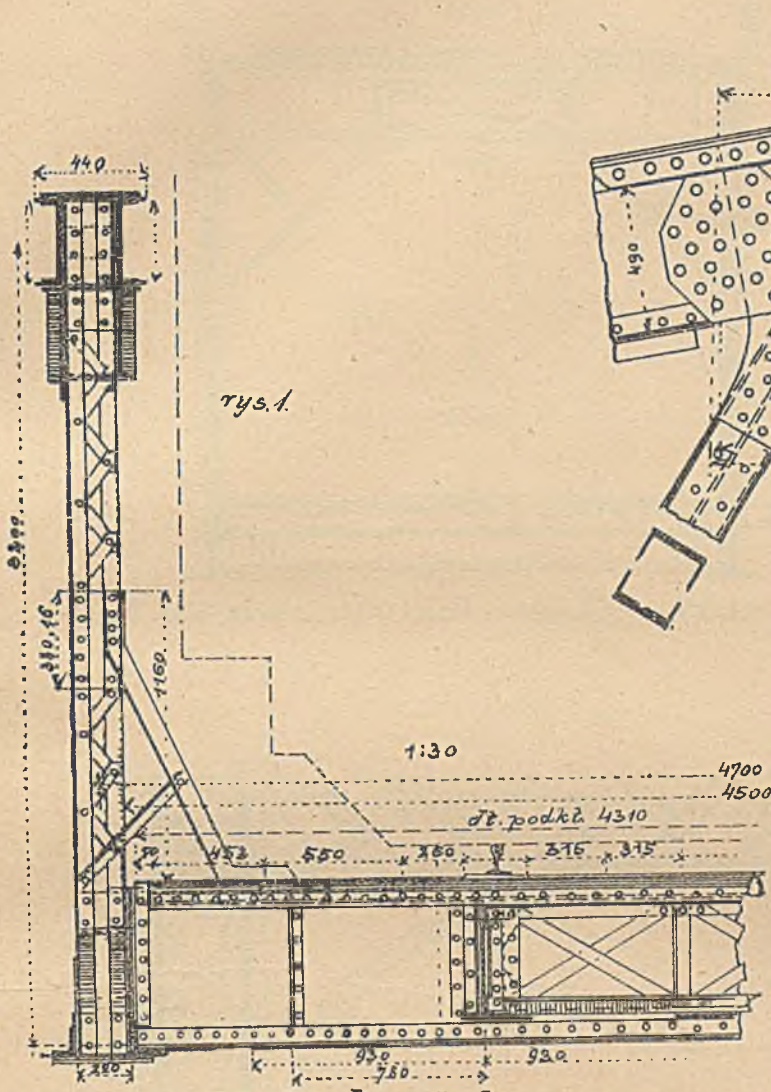

M. kolei Iemid-Angora.

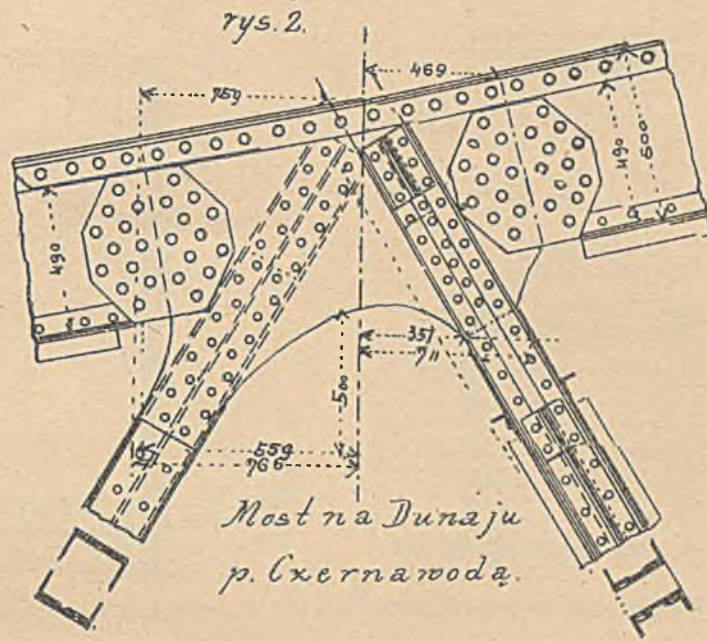

Most na Dunaju
p. Czernawoda.

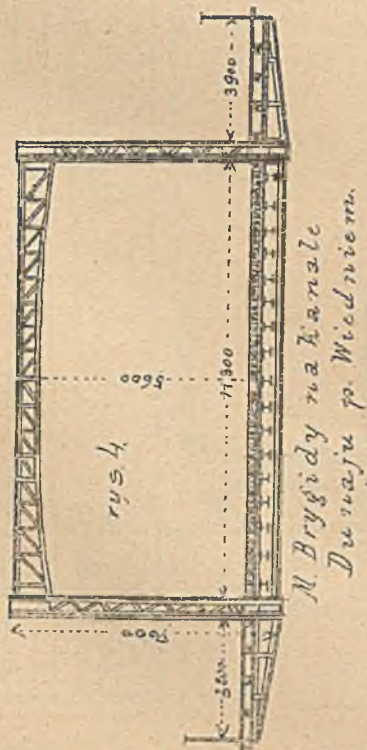

M. Brygidy na kanale
Dunaju p. Wiedniem.

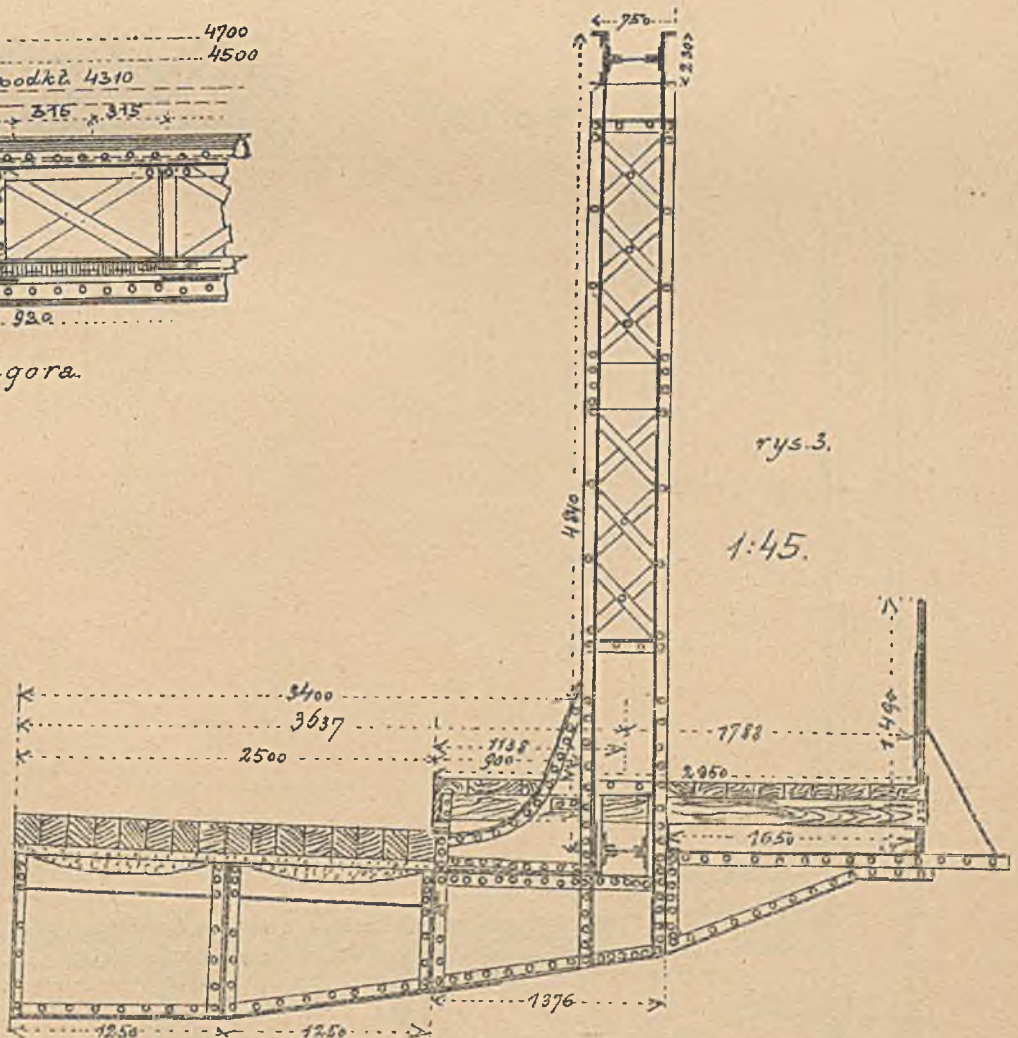

M. na Odrze w Kozlu.

Przekroje poprzeczne

Tabl. 116.

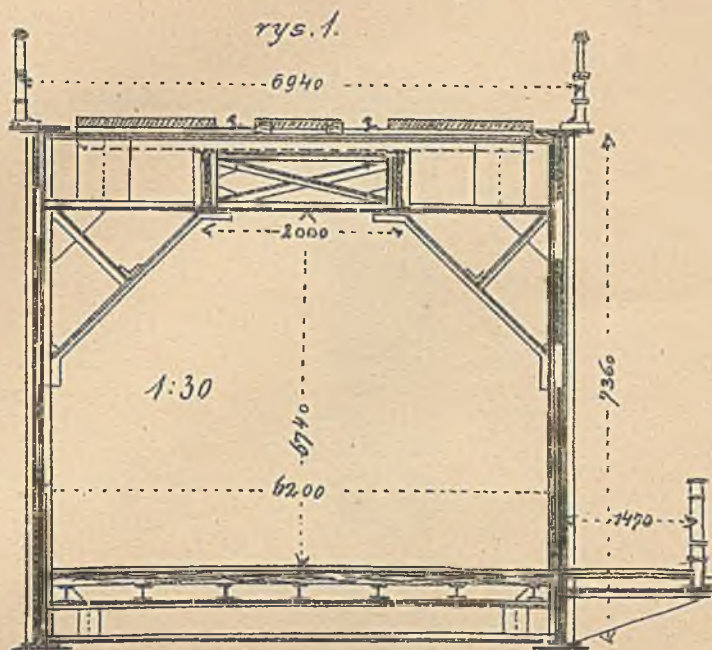

M. kolei austr. półn. zach. na Łabie p. Uściern.

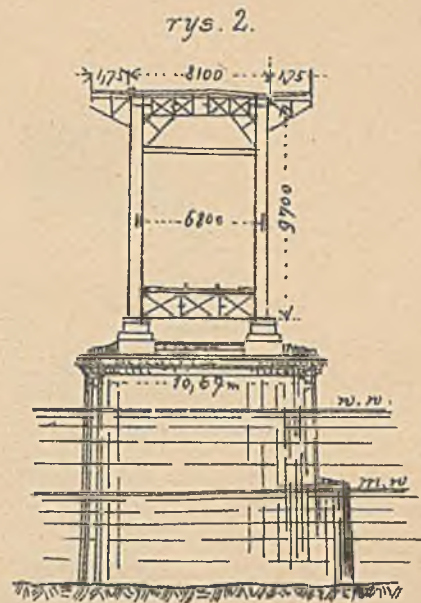

M. na Dnieprze w Jekaterynosławiu.

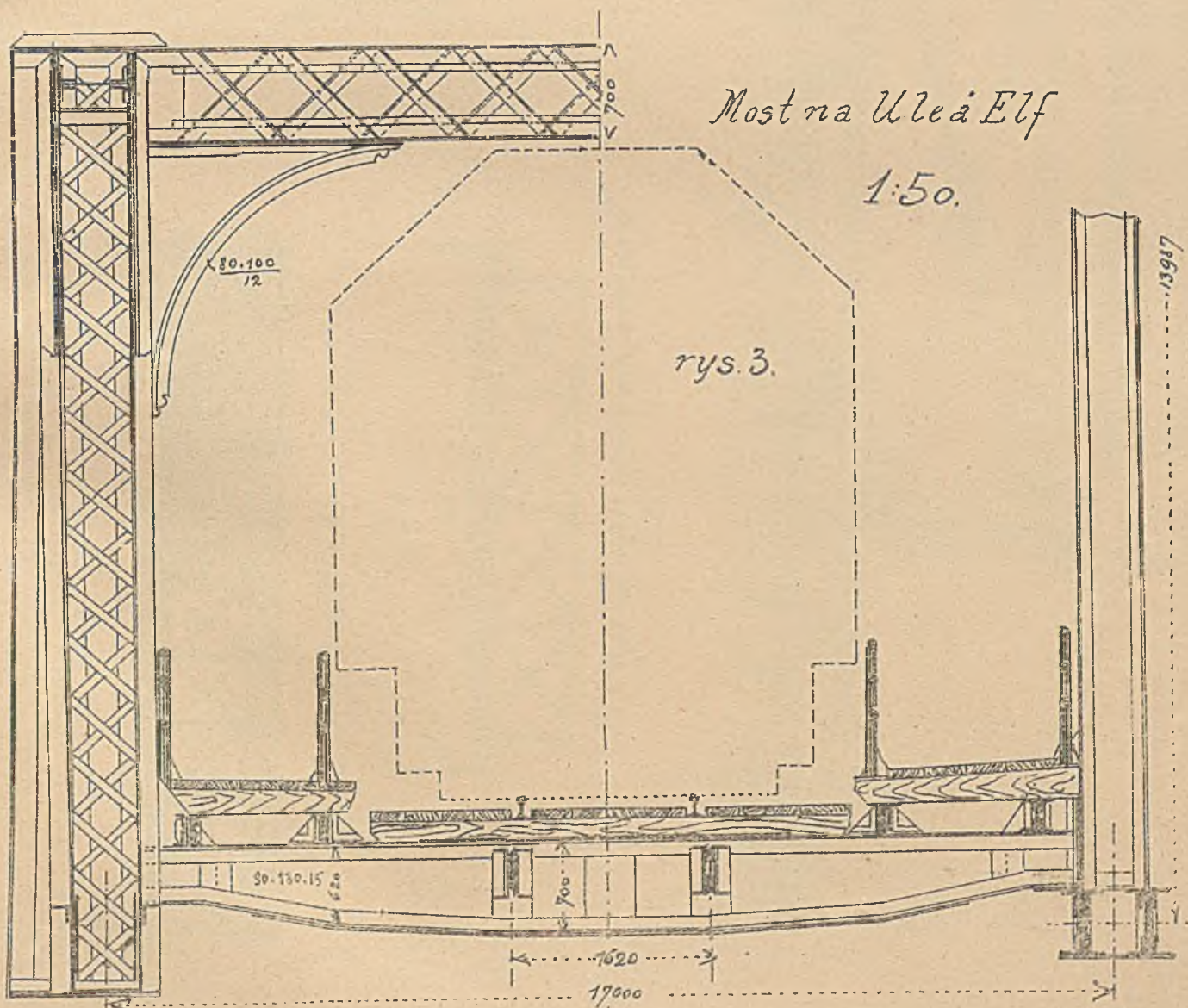

Dr. M. Thullie: Mosty krat. żel.

Odstep belek głównych.

rys. 1

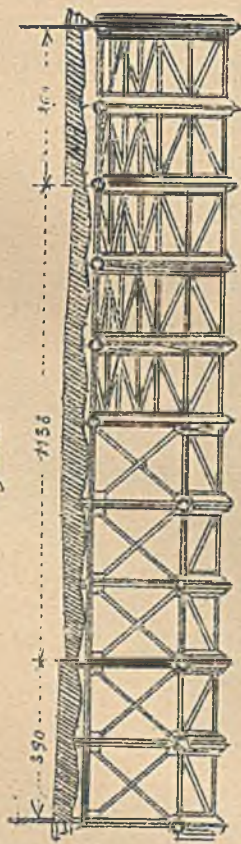

M. Tegethoffa w Wiedniu. 1:100.

rys. 3.

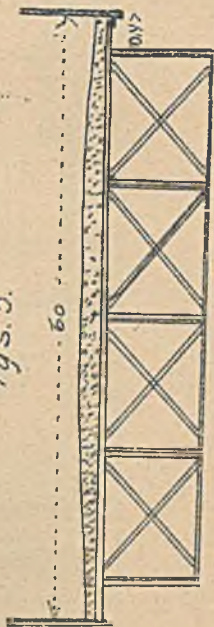

M. drogowy skł. kolei wschodniej. 1:15.

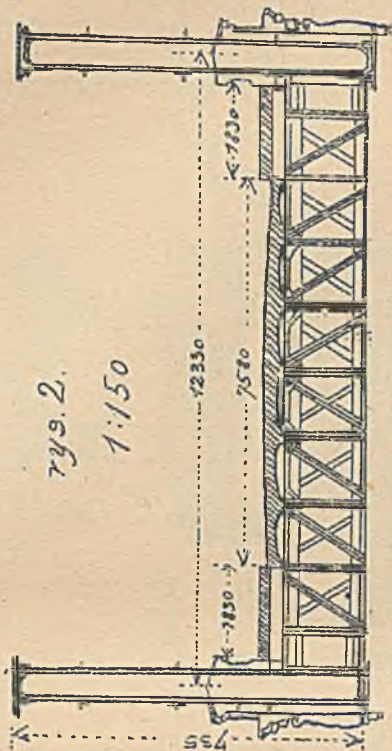

rys. 2.
1:150

M. nadrodze parotn. na Dunaju pod Wiedniem

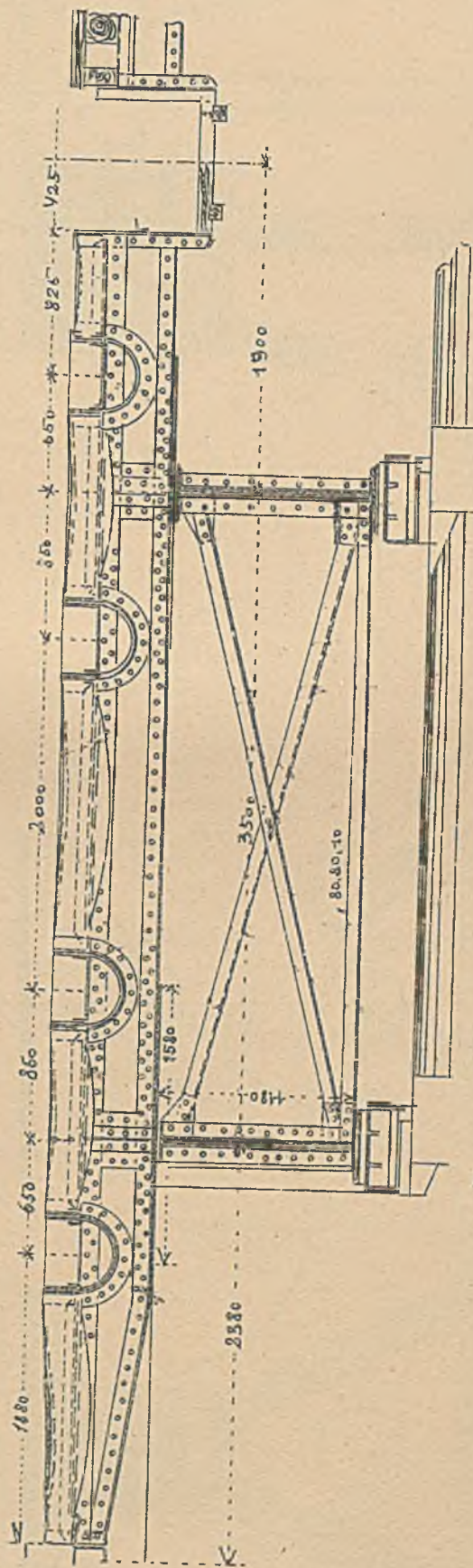

M. na Sprewie w parku Bellevue. 1:40

Projekcja żelazna z murem.
Most na Sumie w Sals

1:10

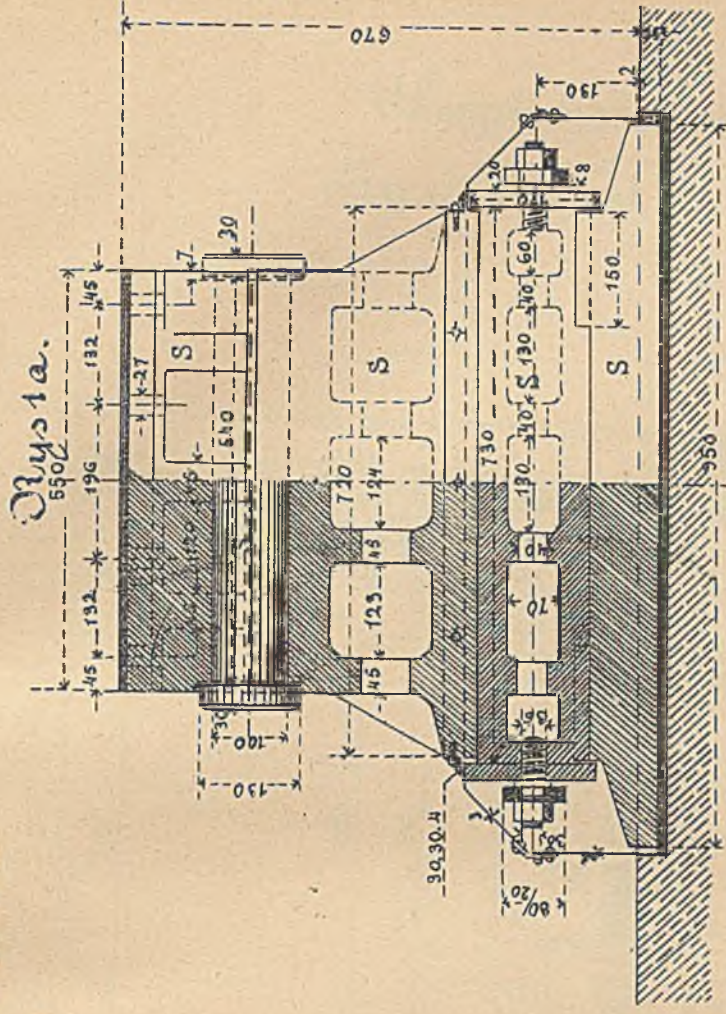
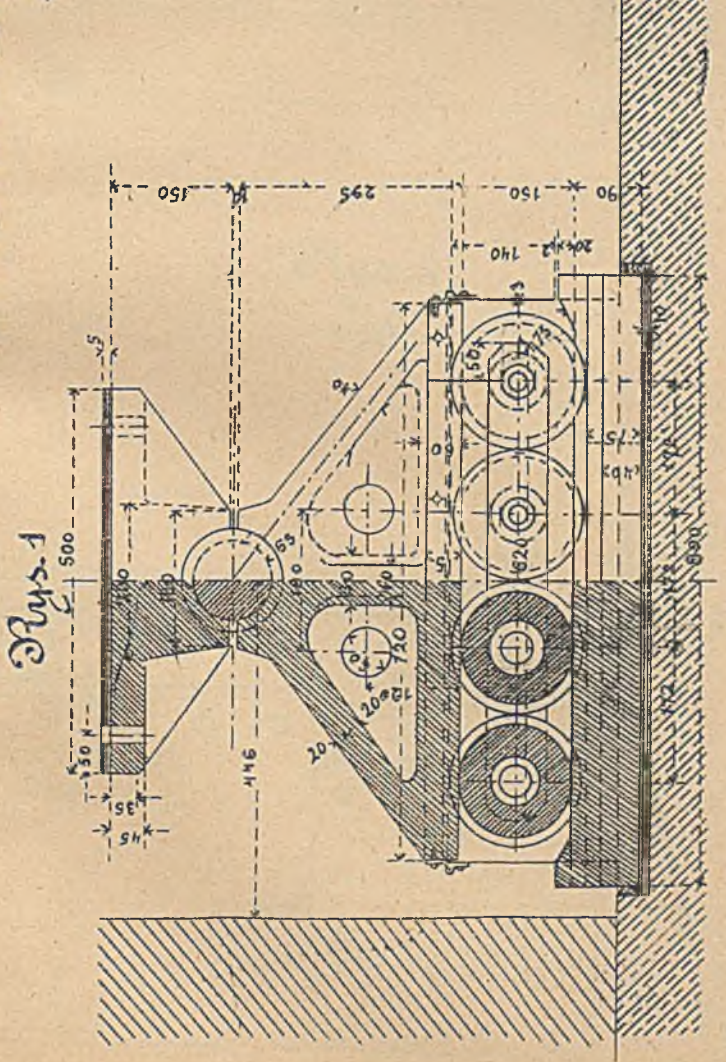

Rys. 2.

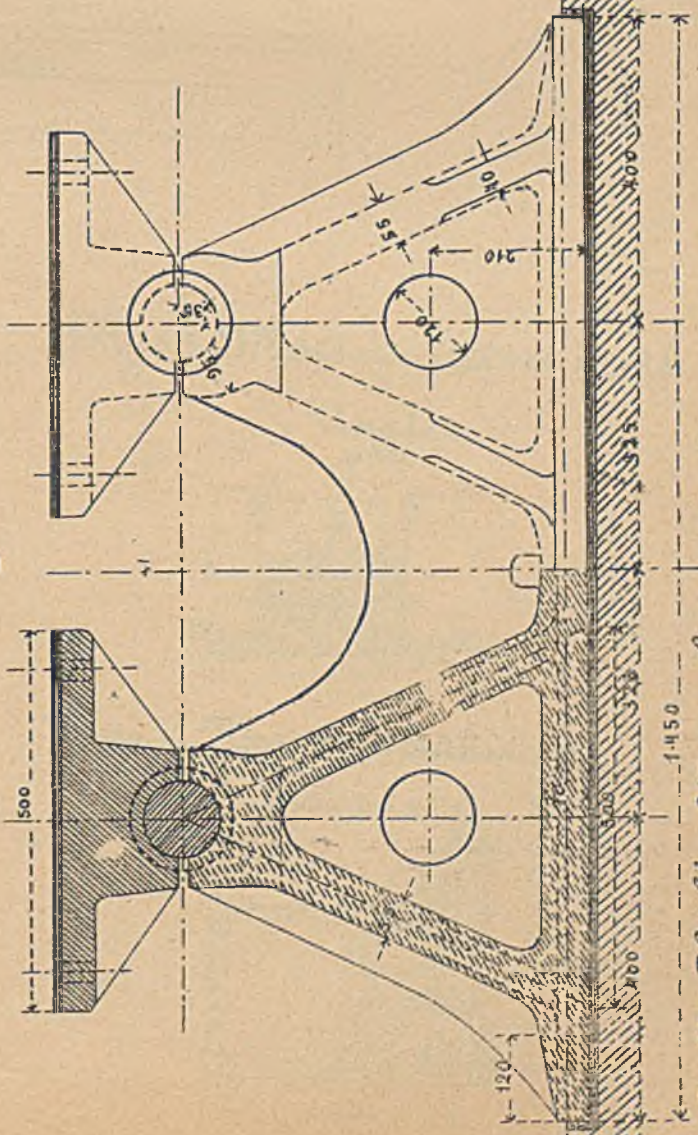

Rys. 2 a.

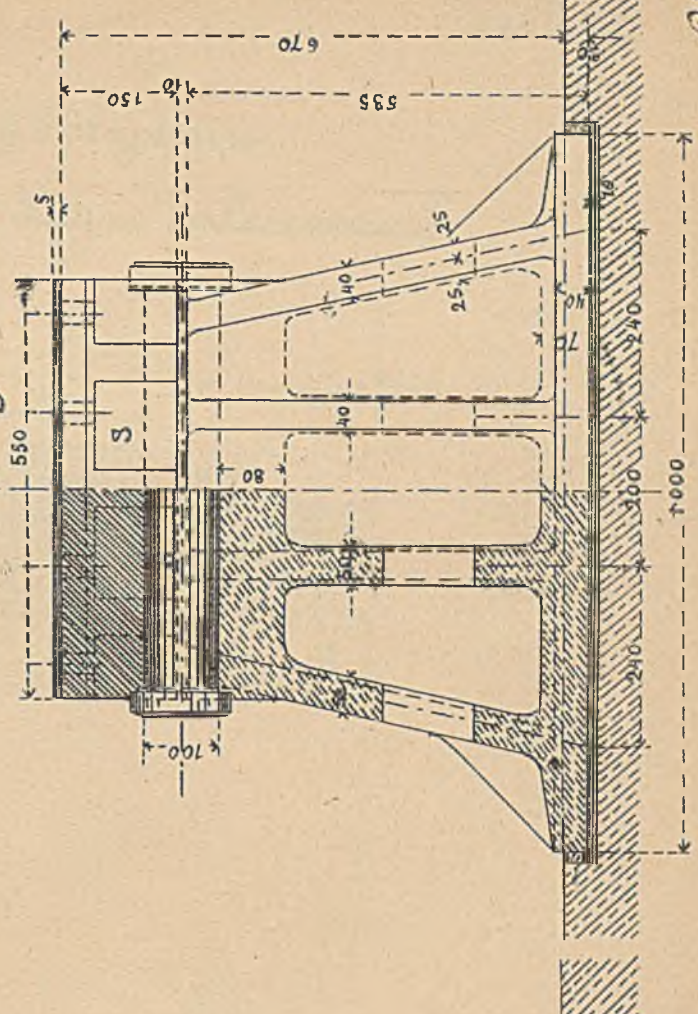

Dr. W. Szulc. Mosty krakow.

Rys. 118

Ubezpieczenie przeciw wykołezieniu.
 Rys. 1. Most na potoku Leg w Zaleszance.

1:10

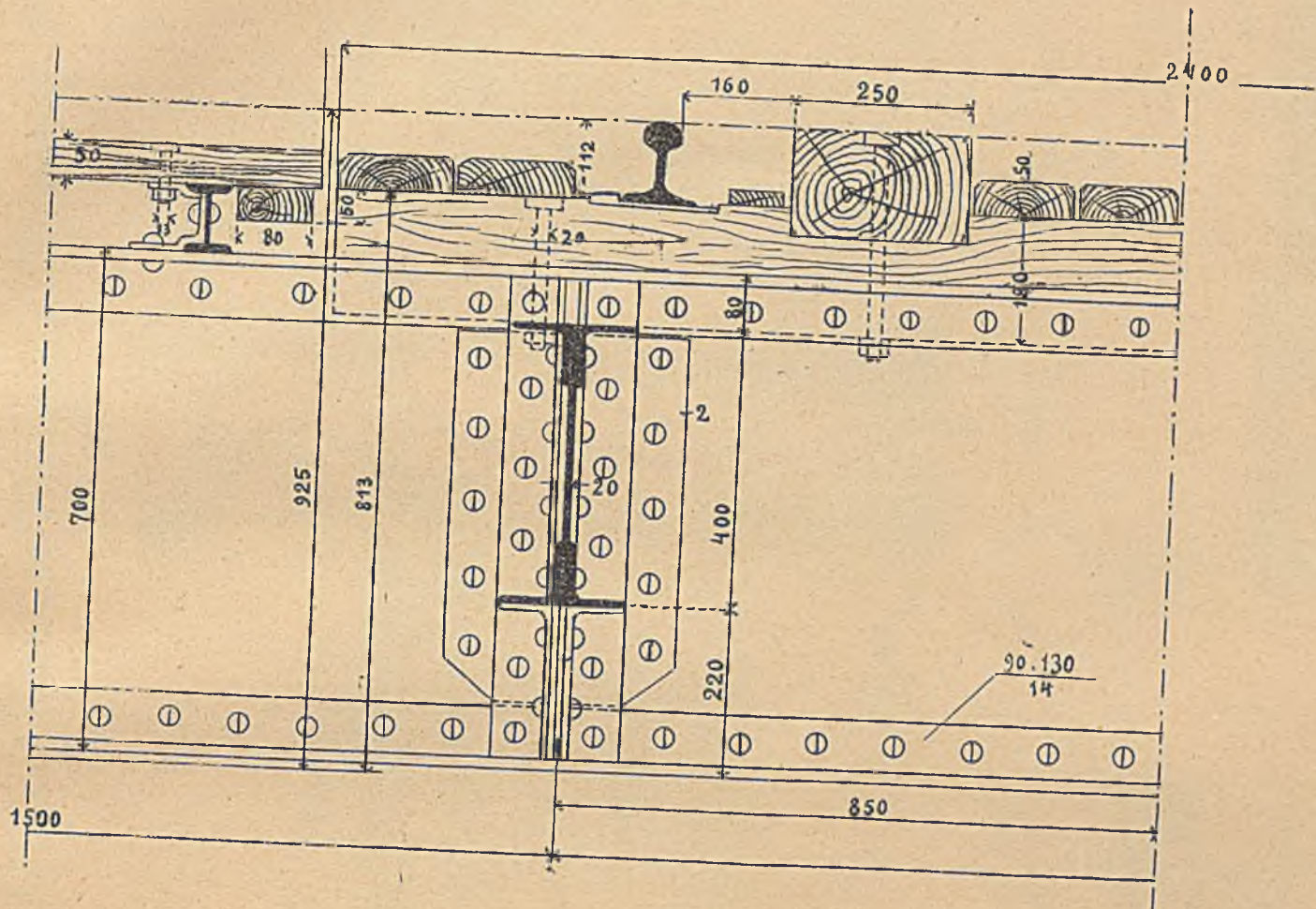

Rys. 2.

1:10

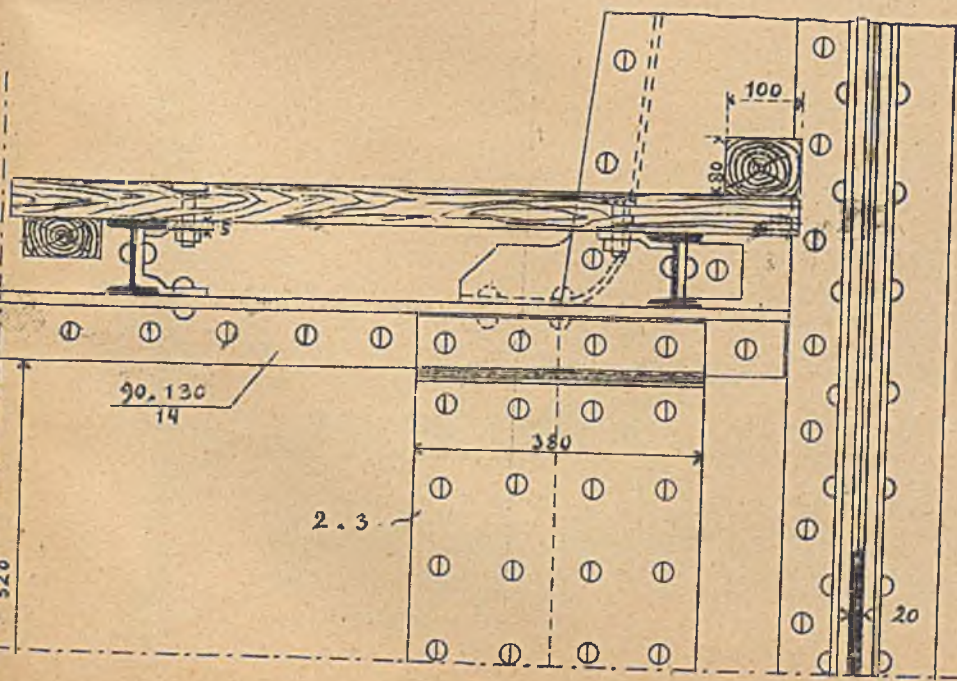

Rys. 3. Most na Zatoce Fortk
 w Anglii.

1:24

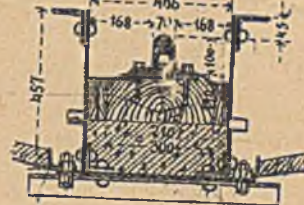

Rys. 4. Most na Atbarre w
 Sudanie.

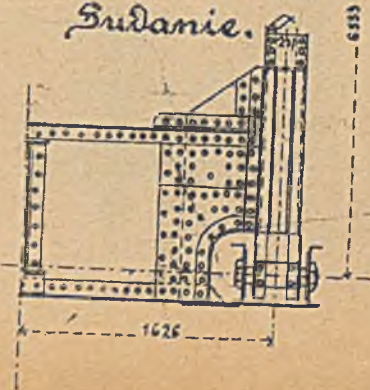

8.3

Ograniczenie drogi od skobnika.

Rys. 2. Most na Dnie w Świętosławiu.

1:15

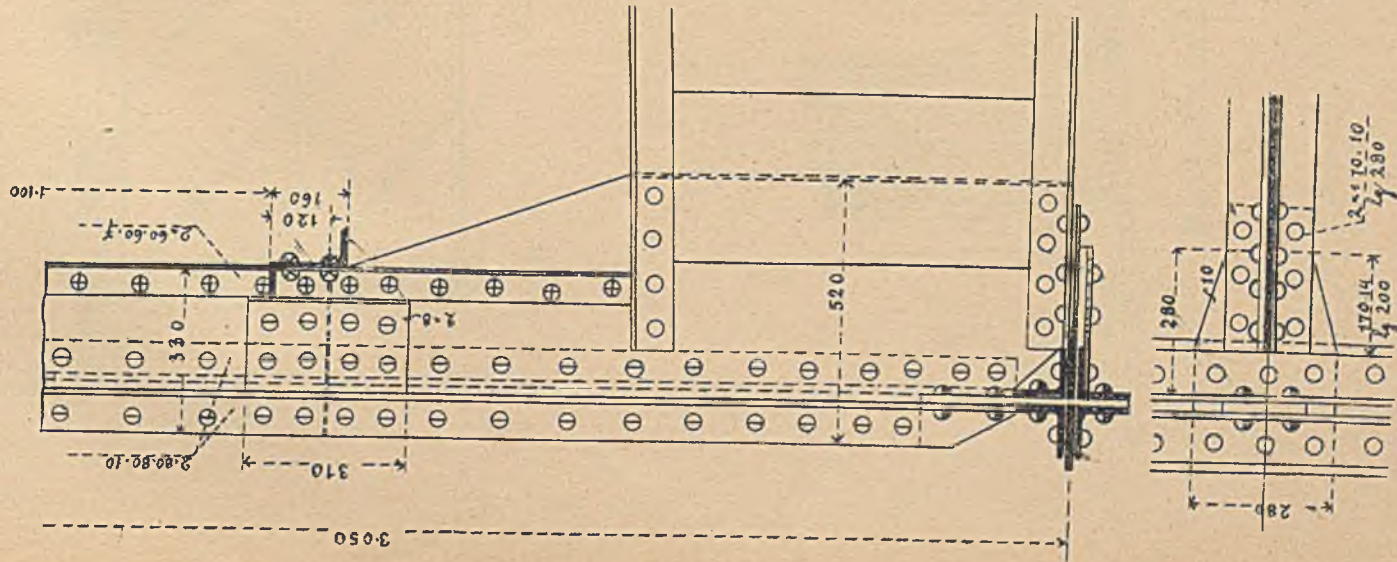

Rys. 1. Most na Niedence w Hadersdorf-Weidlingen.

1:15

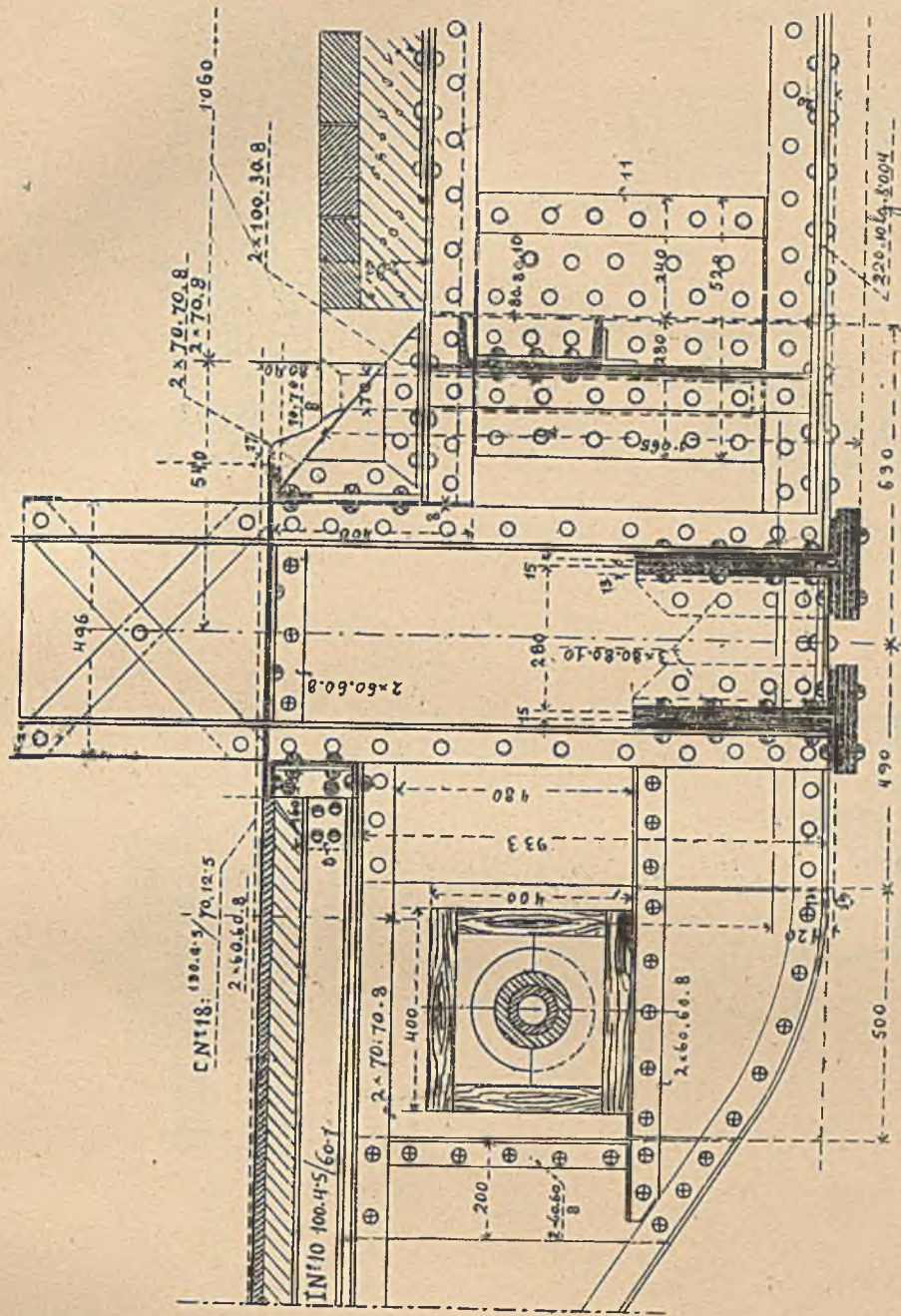

Rys. 3. Most na Mbenie w Gltmann.

1:15

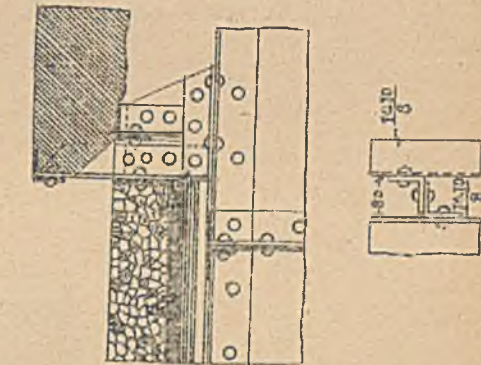

Rys. 4. Szejardgóra, na dwoem w Minden

1:20

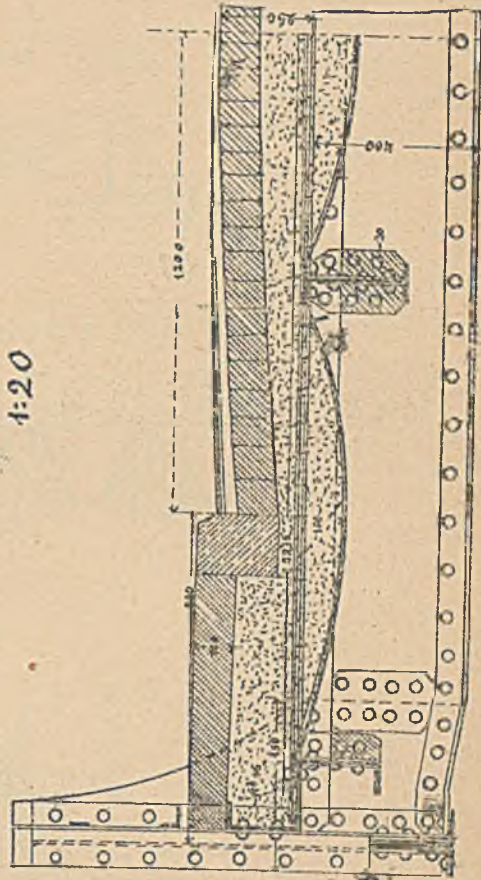

Dr. M. S. 11. 11

Odbojnice.

Tabl. 121.

rys. 1.

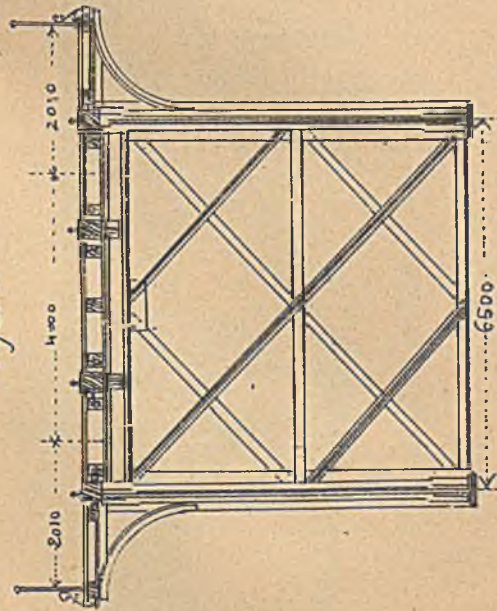

M. na Renie p. Waldhut.

rys. 2.



M. kolei Wieden Sottendorf

1:30

rys. 3.

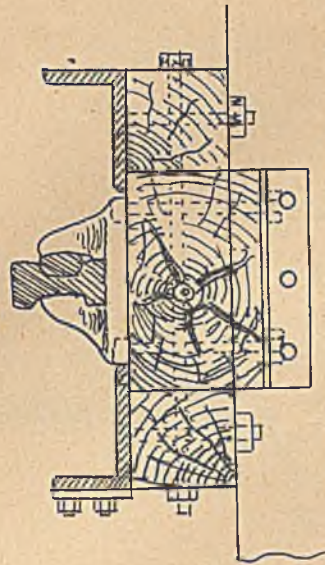

M. Britannia (Anglia).

rys. 4.

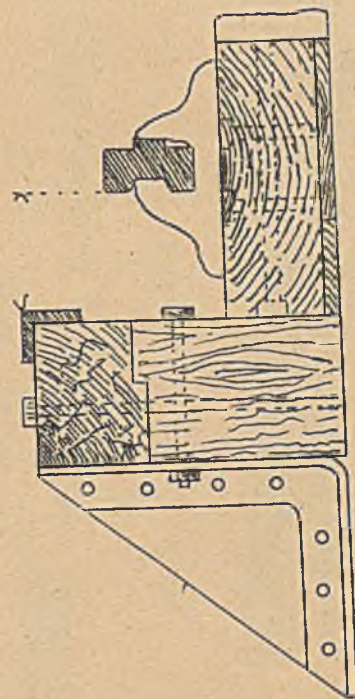

Most Ribble.

Dr. Thullie: Mosty krat. iel.

rys. 5.

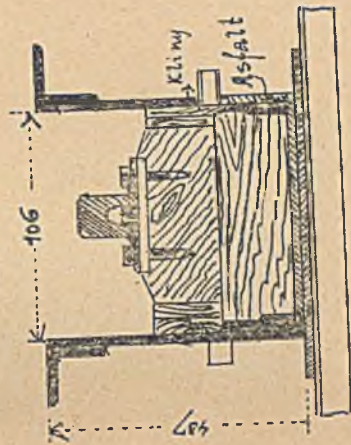

M. na xatoce Forth

1:14.

rys. 6.



Most Chrenat v Indjach.

rys. 7.

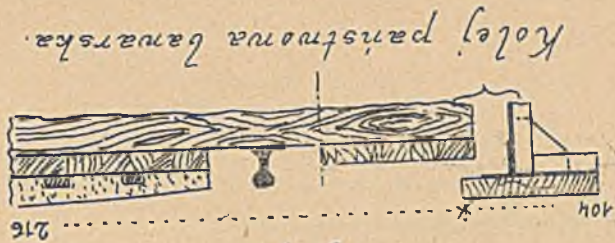

Kolej panstwowa warszka.

Ustrój pomostu mostów drogowych.

rys. 1.

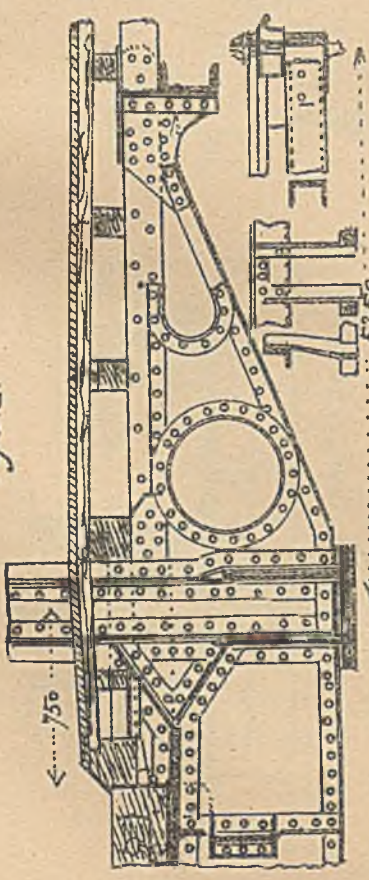

M. na Wexerze w Bremie.

rys. 2.

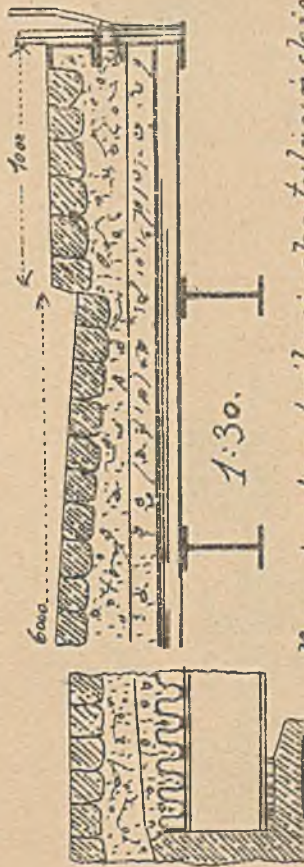

M. na drodze królewiecko-tylżyńskiej.

rys. 3.

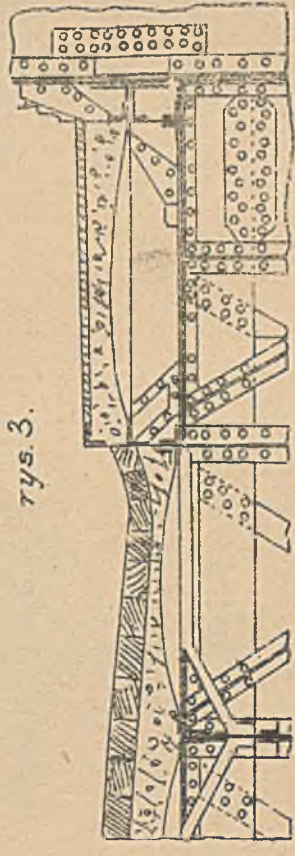

M. na Dunaju we Wiedniu. 1:30.

Dr. M. Thullie: Mosty krat. iel.

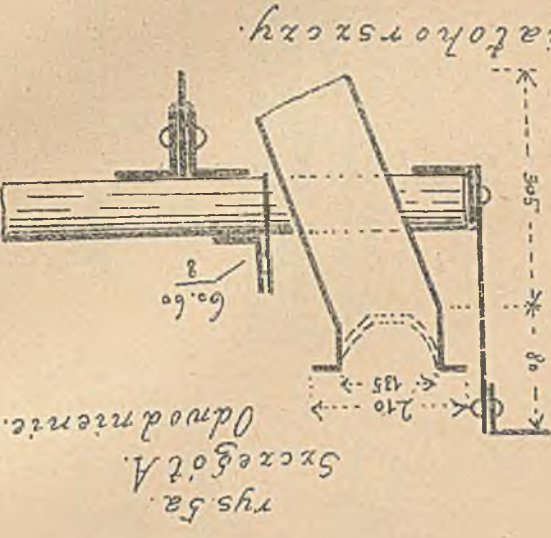

rys. 5a. Szregöt A. Odnodnienie.

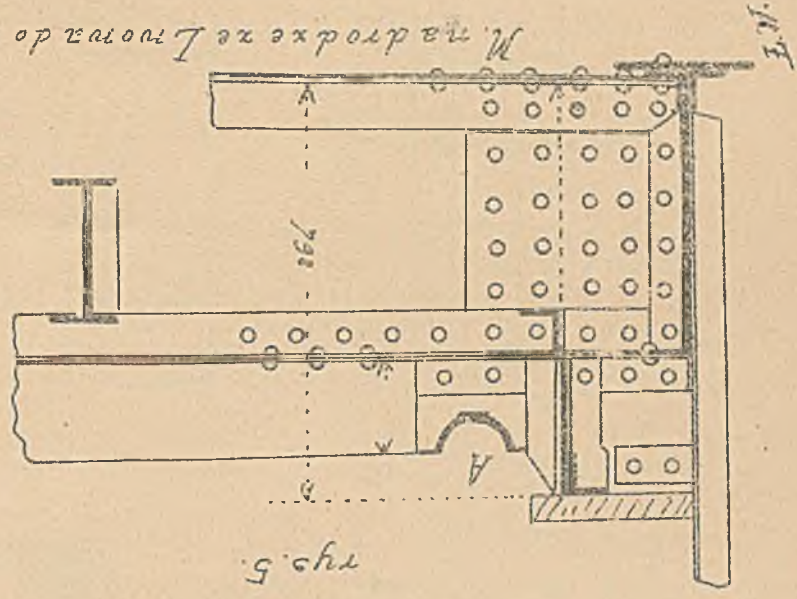

M. na drodze ze Lwowa do Białohorszczy.

rys. 5.

M. na Sprewe w Berlinie.

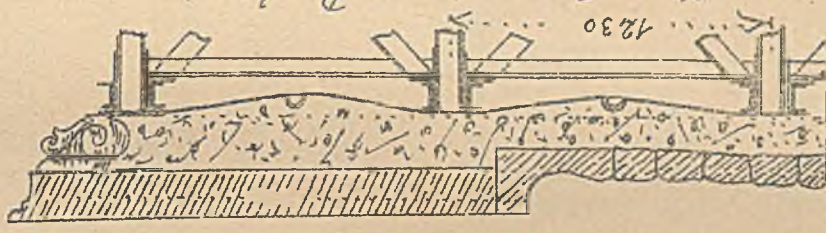

rys. 4. 1:30.

Polaczenie podtulnic z poprzecznicami Tabl. 123

rys. 1.

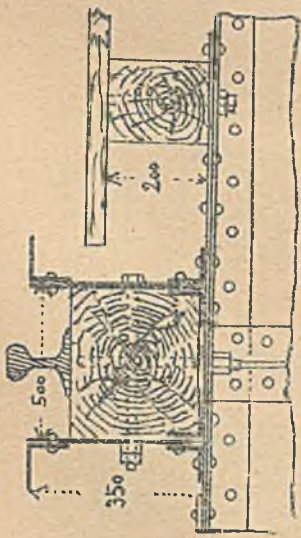

M. na Cervato we Włoszech.
1:15.

rys. 2.

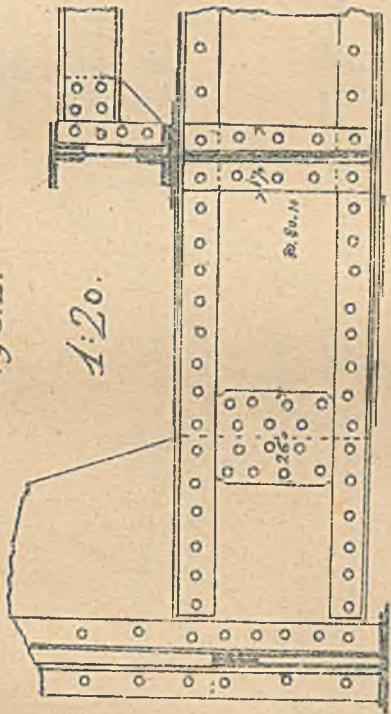

Podjazd w Osterfeld.

rys. 3.

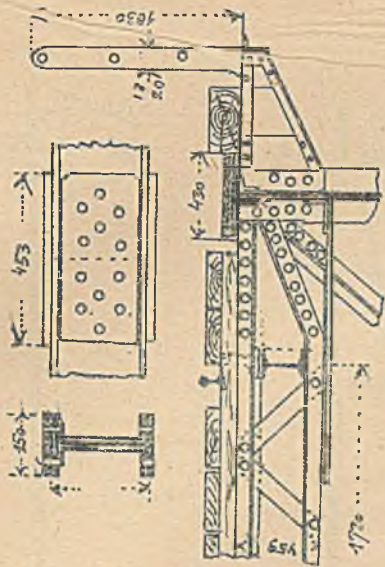

M. na Dunaju p. Zwiefaltendorf.

rys. 5.

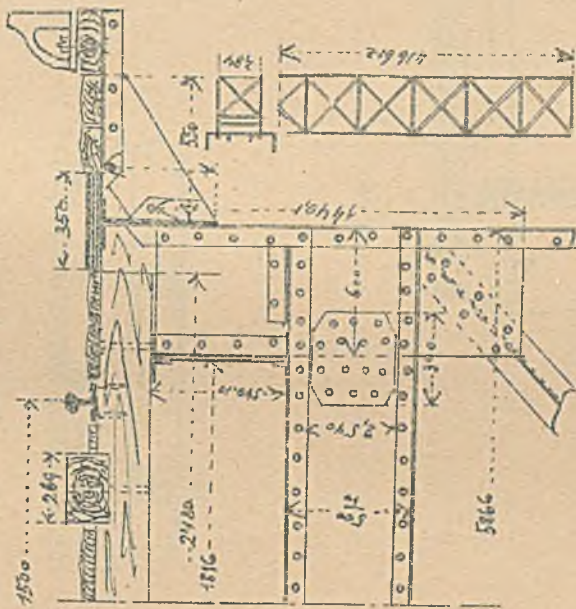

M. kolei Rakonnicko-protiniviskiej

rys. 4.

1:20.

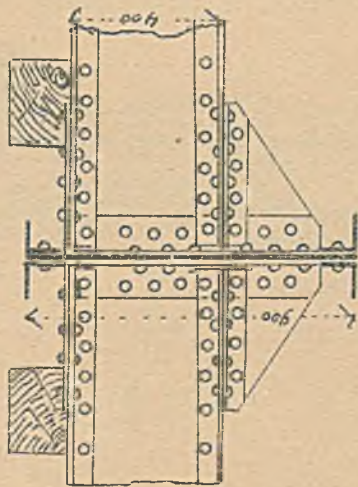

M. na Lecku p. Krailenburgiem.

rys. 6.



rys. 7.



E.M.

Dr. M. Thullie: Mosty krat. zel.

Połączenie podtukiwnic x poprzecznicami.

rys. 1

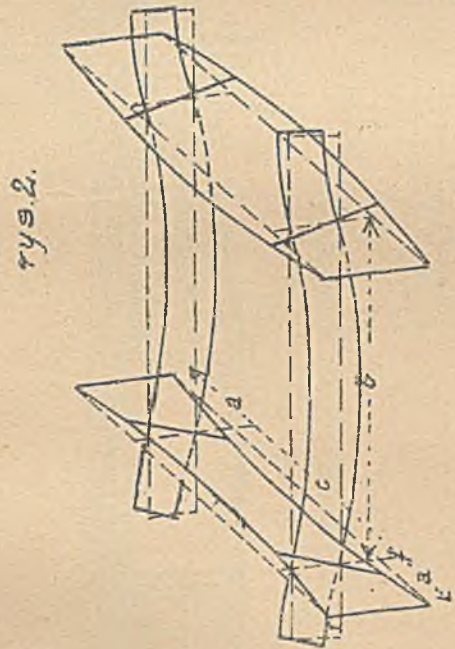

rys. 2.

rys. 3.



rys. 4.

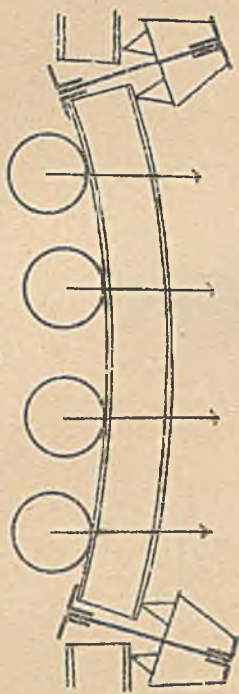

Frejard góra nadmorem w Minden.

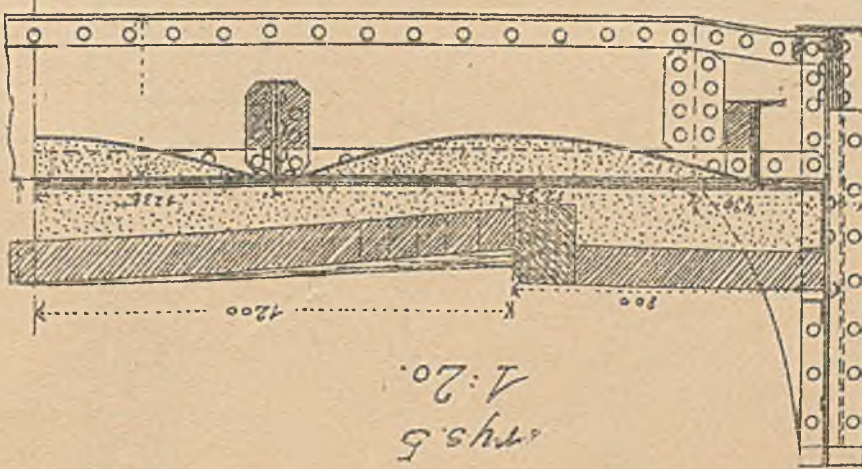

rys. 5
1:20.

rys. 6 a.



rys. 6.

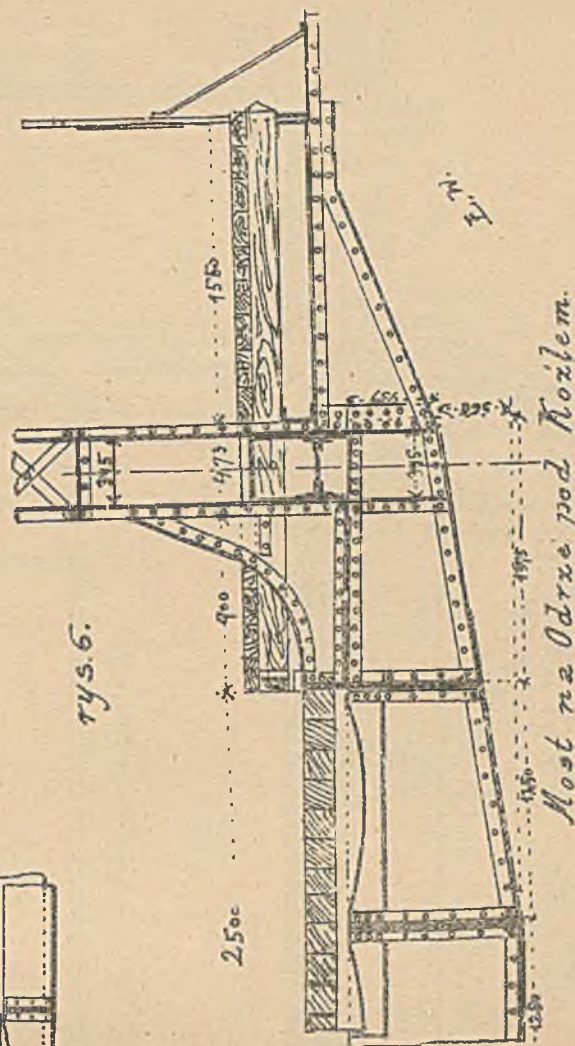

Odgraniczenie drogi i chodnika.

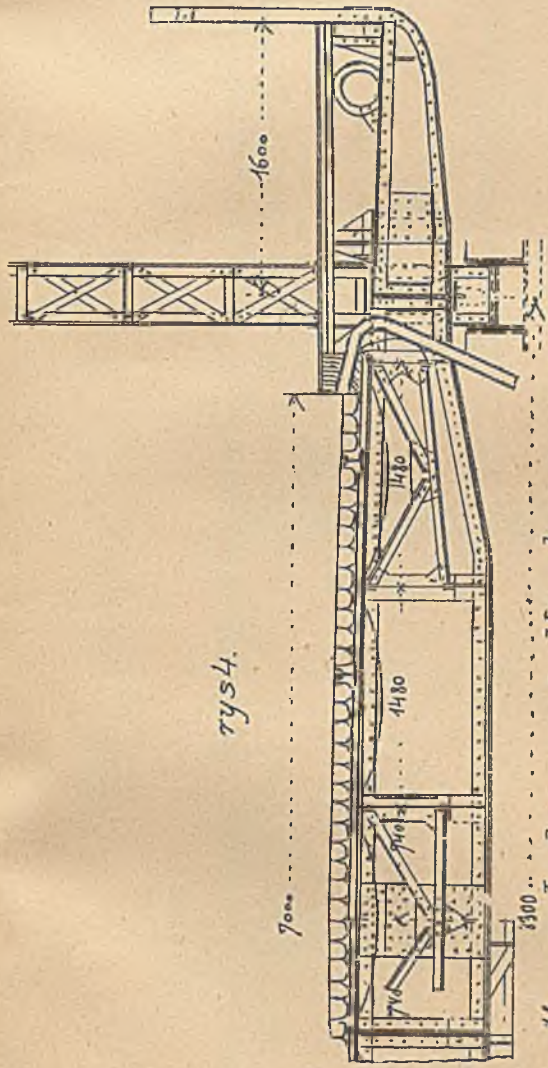

rys. 4.

M. na Labie pod Harburgiem. rys. 2.

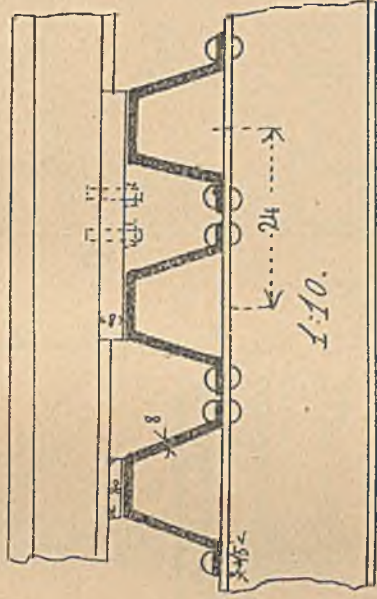

M. na Iglanie w Iwanoczybach. rys. 1.

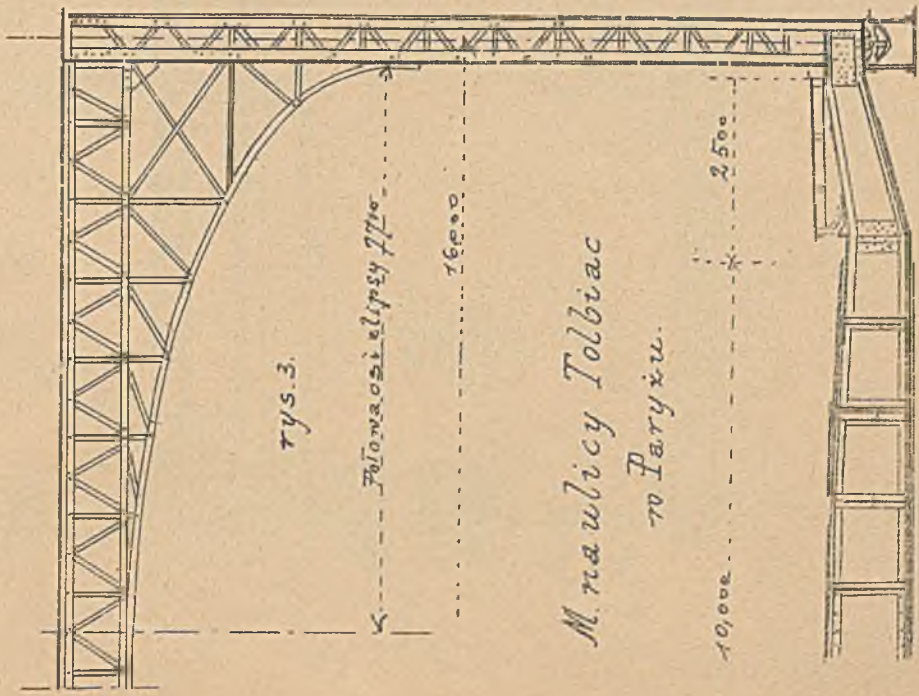

rys. 3.

M. na ulicy Tolbiac w Paryżu.

M. na Thullie. Mosty krat. xel.

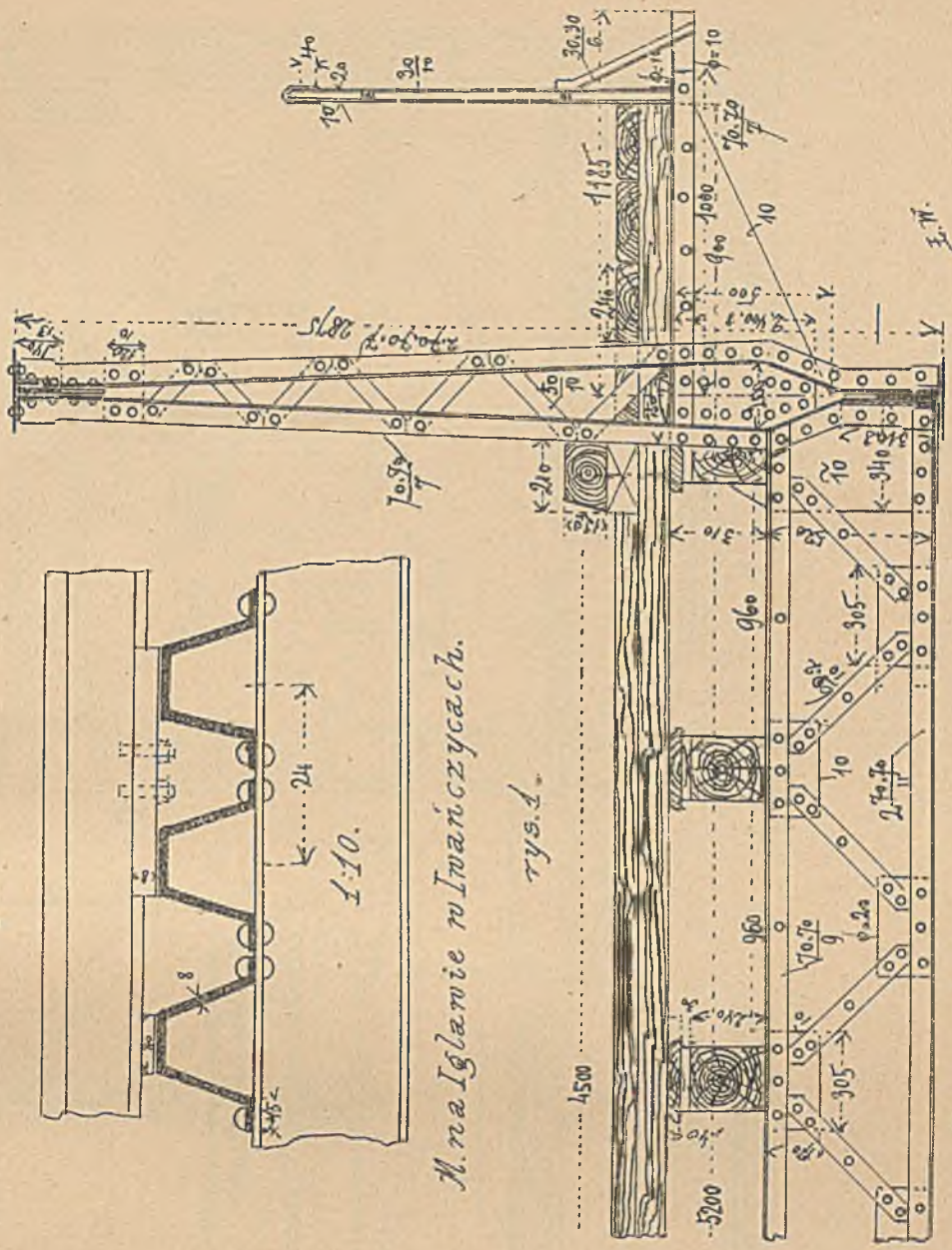

rys. 1.

M. na Noteci p. Oburnem w Poznańskiem.

Most na Wotdxe pod Iverem.

Tab 126.

rys. 1. Widok.

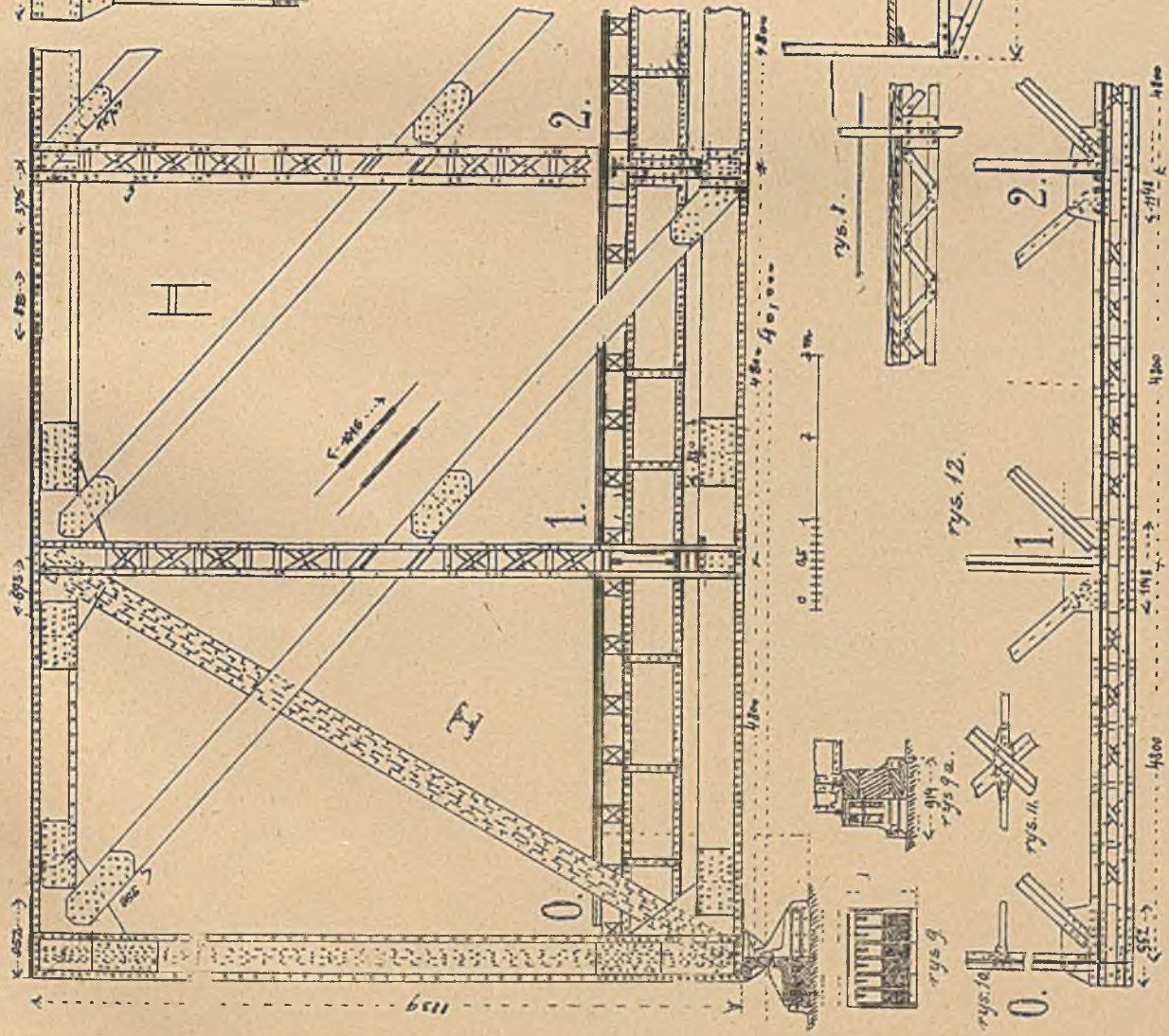

rys. 2. Widok z góry.

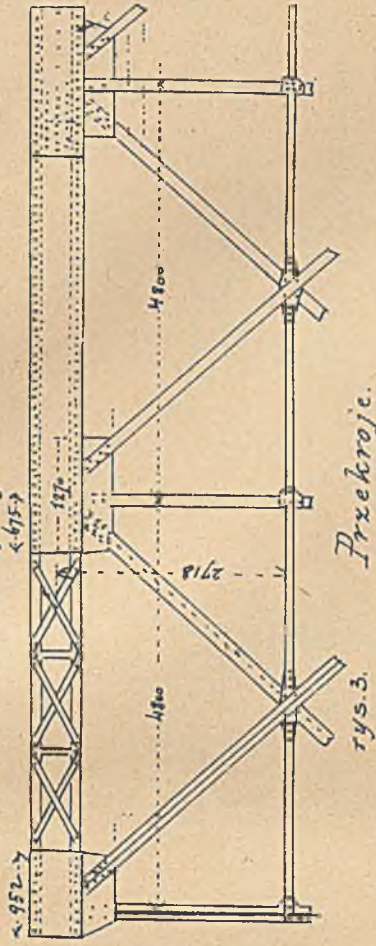

rys. 3. Przekroje.

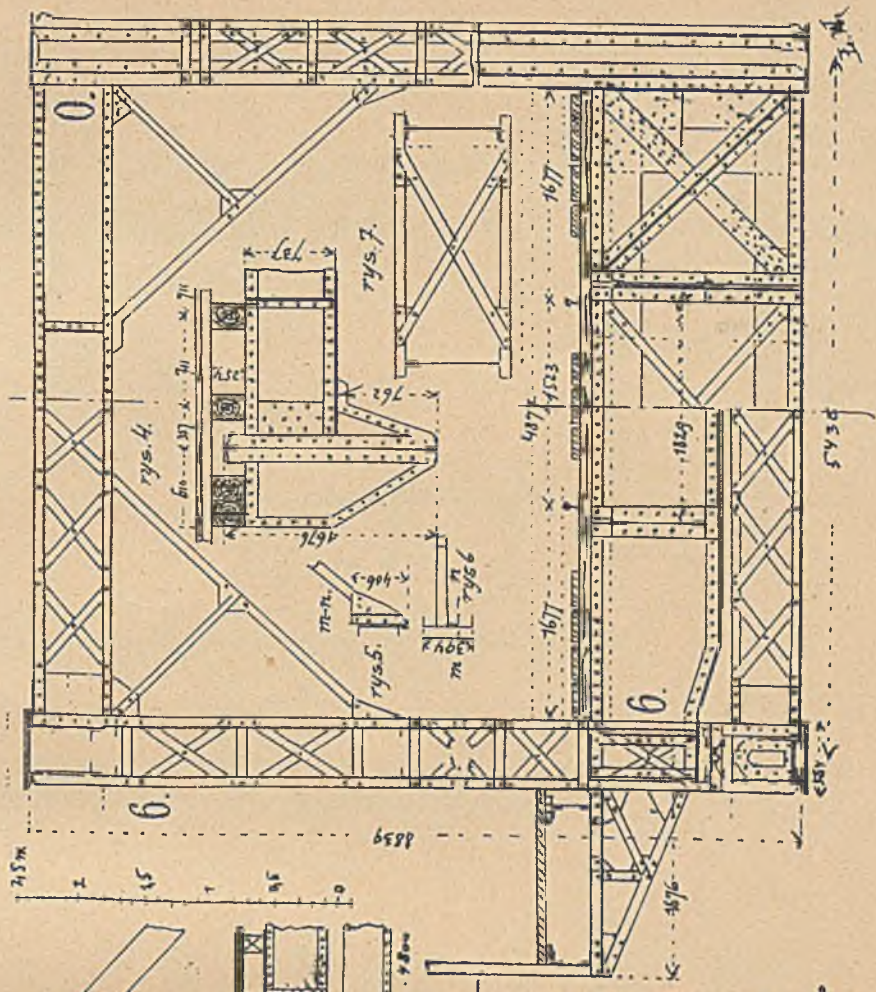

D^r M Thullie: Mosly kral. i.c.l.

Most na Saarze pod Saarbrücken.

Tabl. 127.

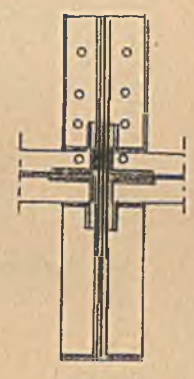
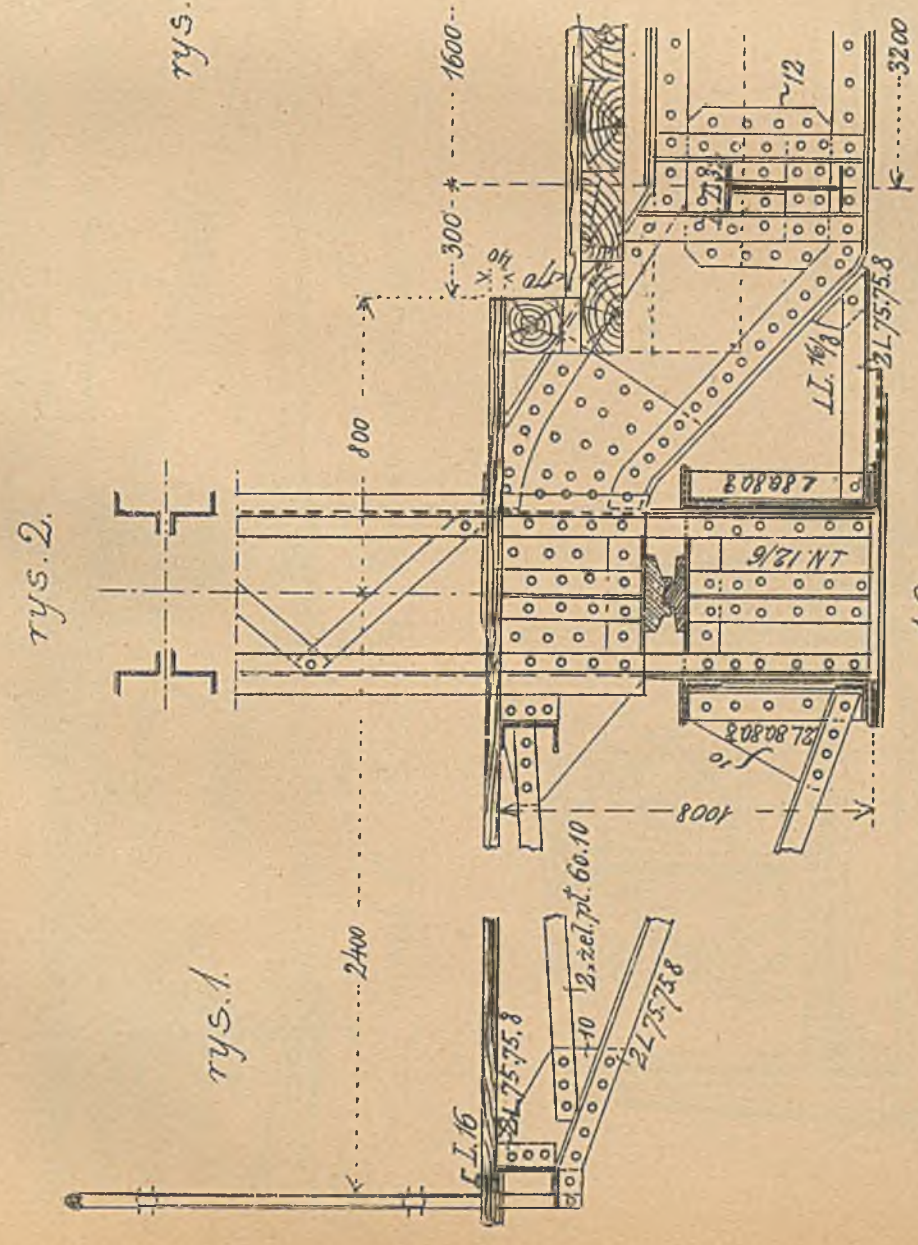

1:20.

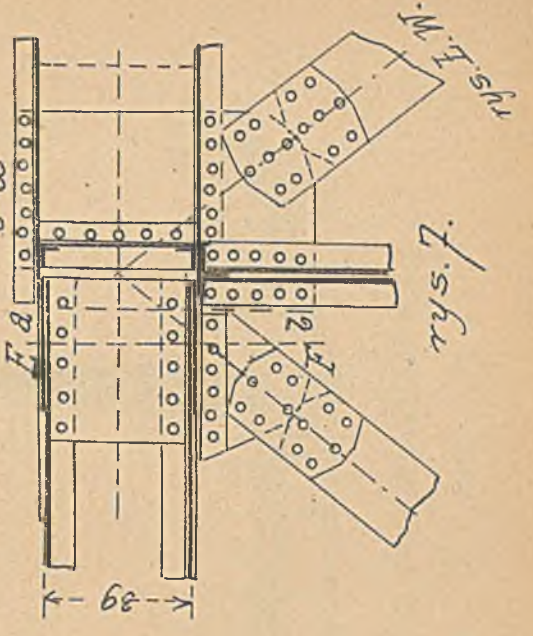
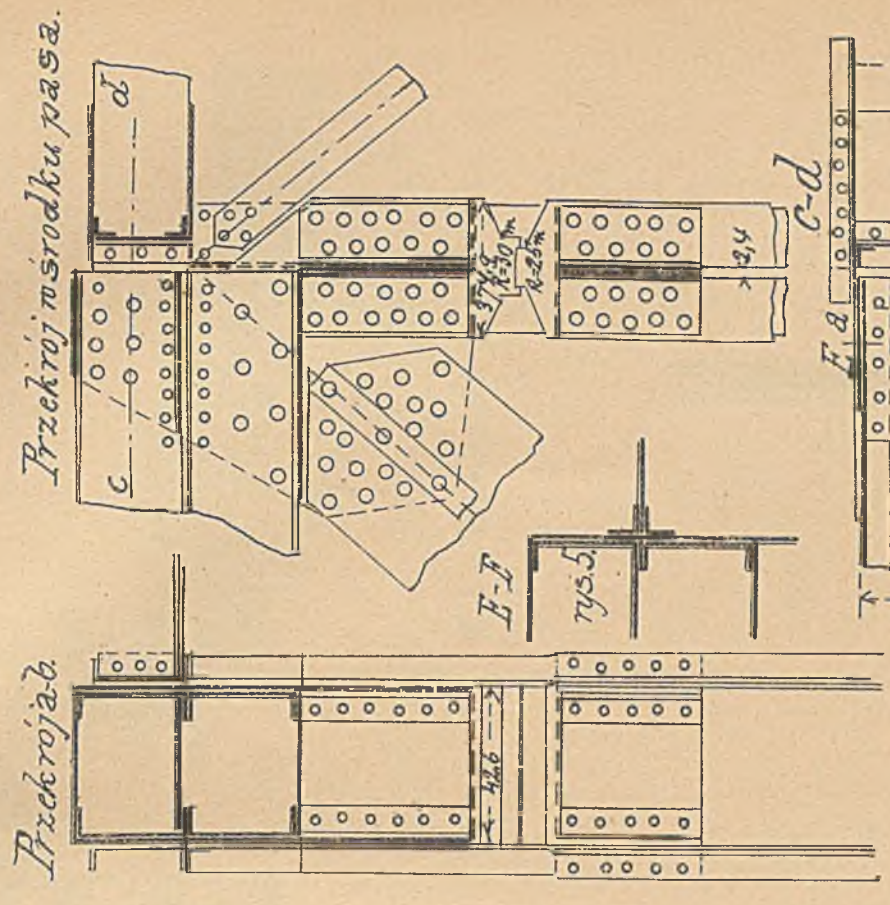

Dr. M. Thullie. Mosty krat. iel.

Odgraniczenie drogi od chodnika.

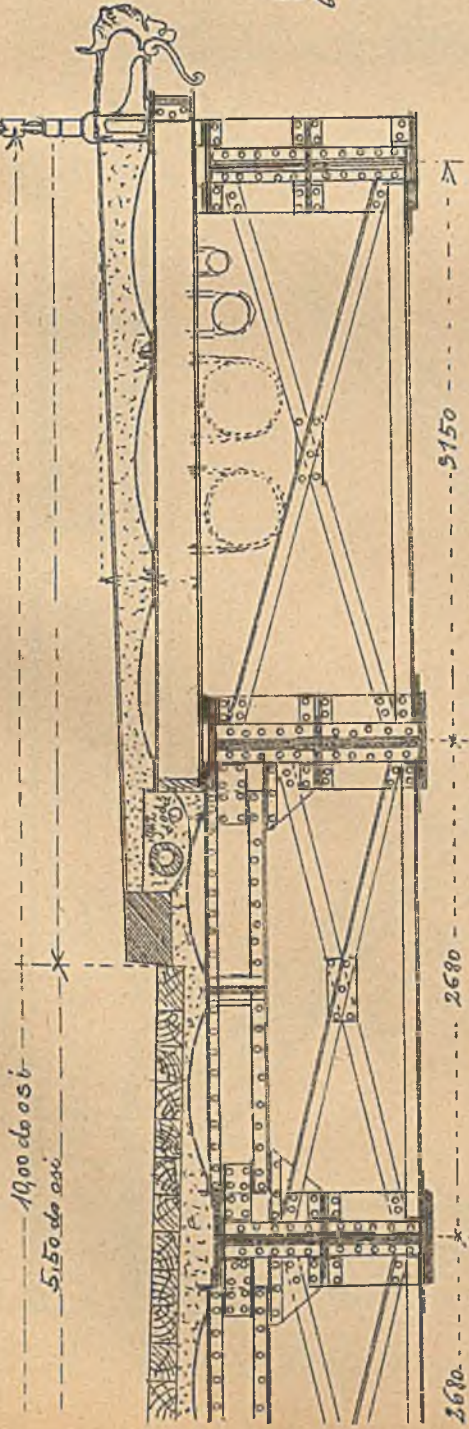

rys. 1. Most na Rodanie w Lionie.

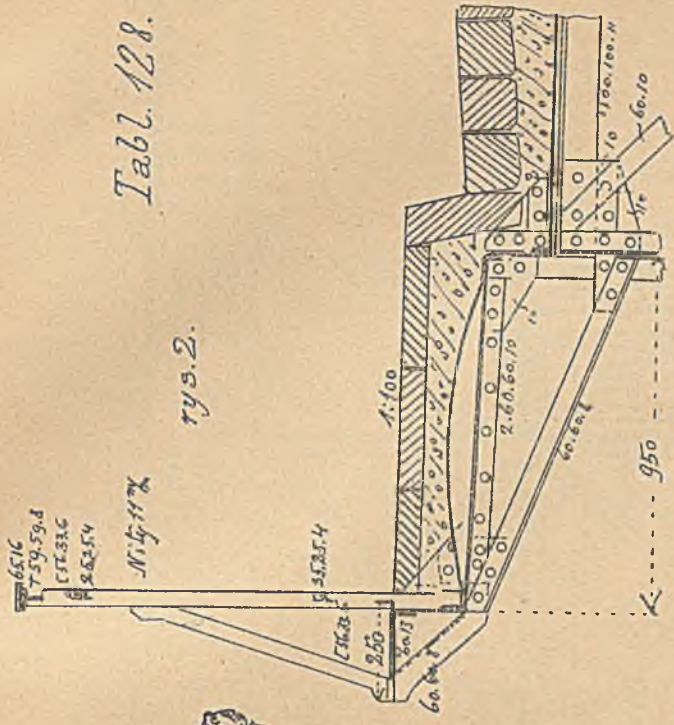

Tabl. 128.

rys. 2.

M. na Wexerze w Hoya.

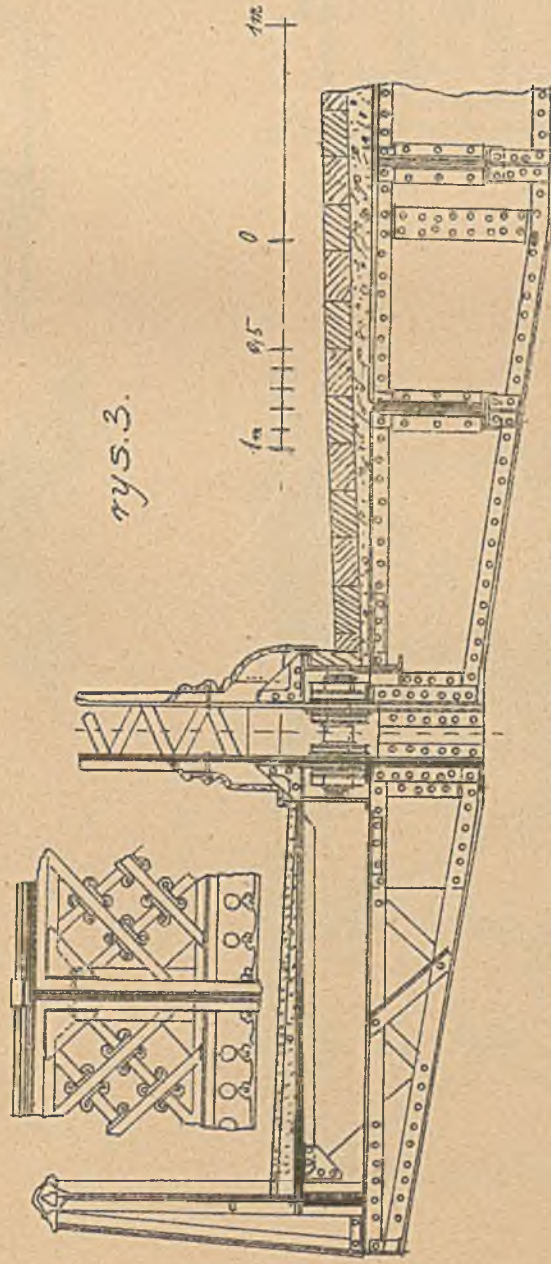

rys. 3.

M. na rzece Taff w Cardiff.

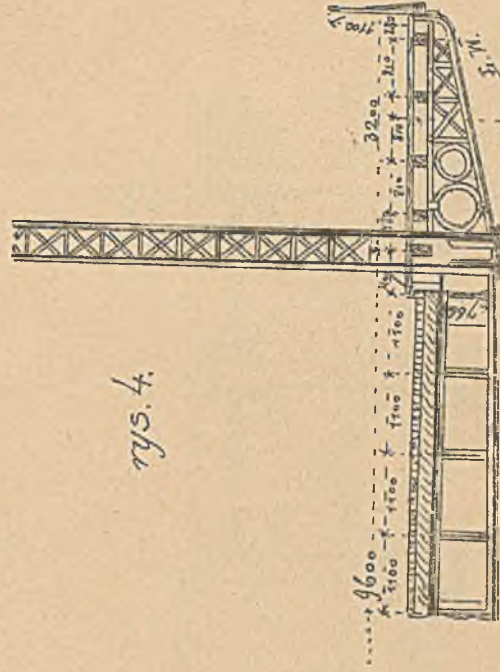

rys. 4.

M. Franciszka Józefa na Dunaju pod Wiedniem.

Dr. M. Thullie: Mosty krat. iel.

rys. 1

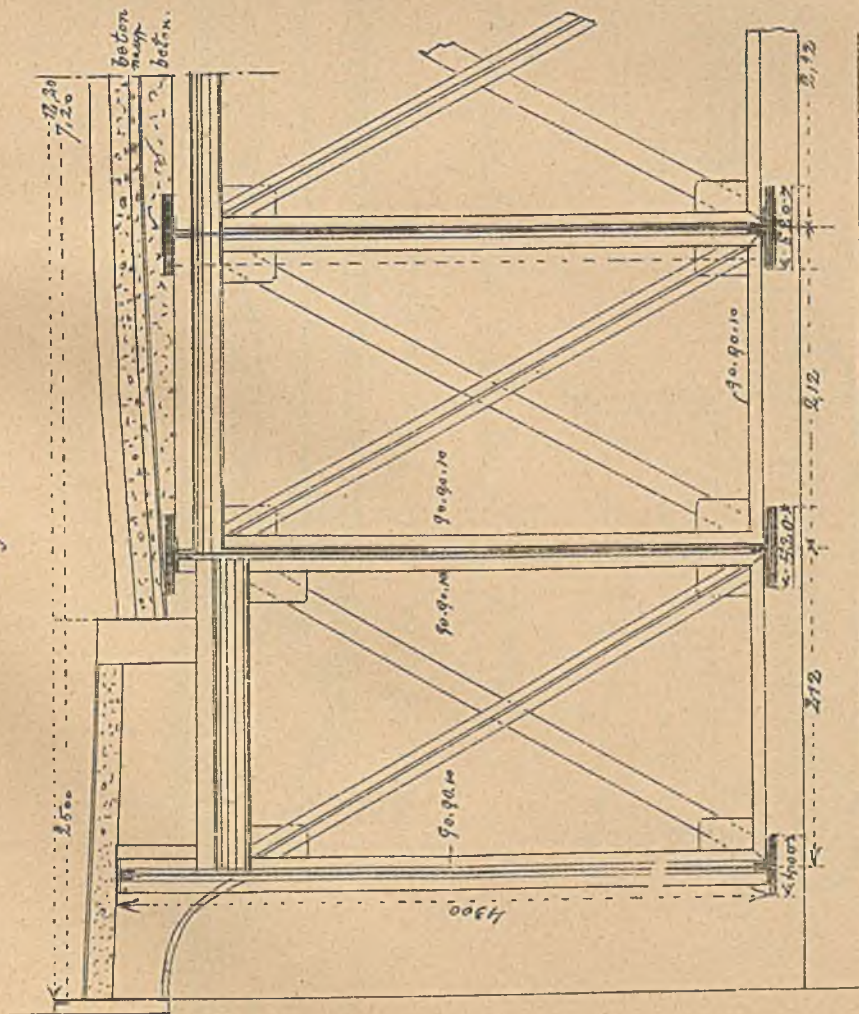

M. kolei wschodniej w Paryżu.

rys. 2

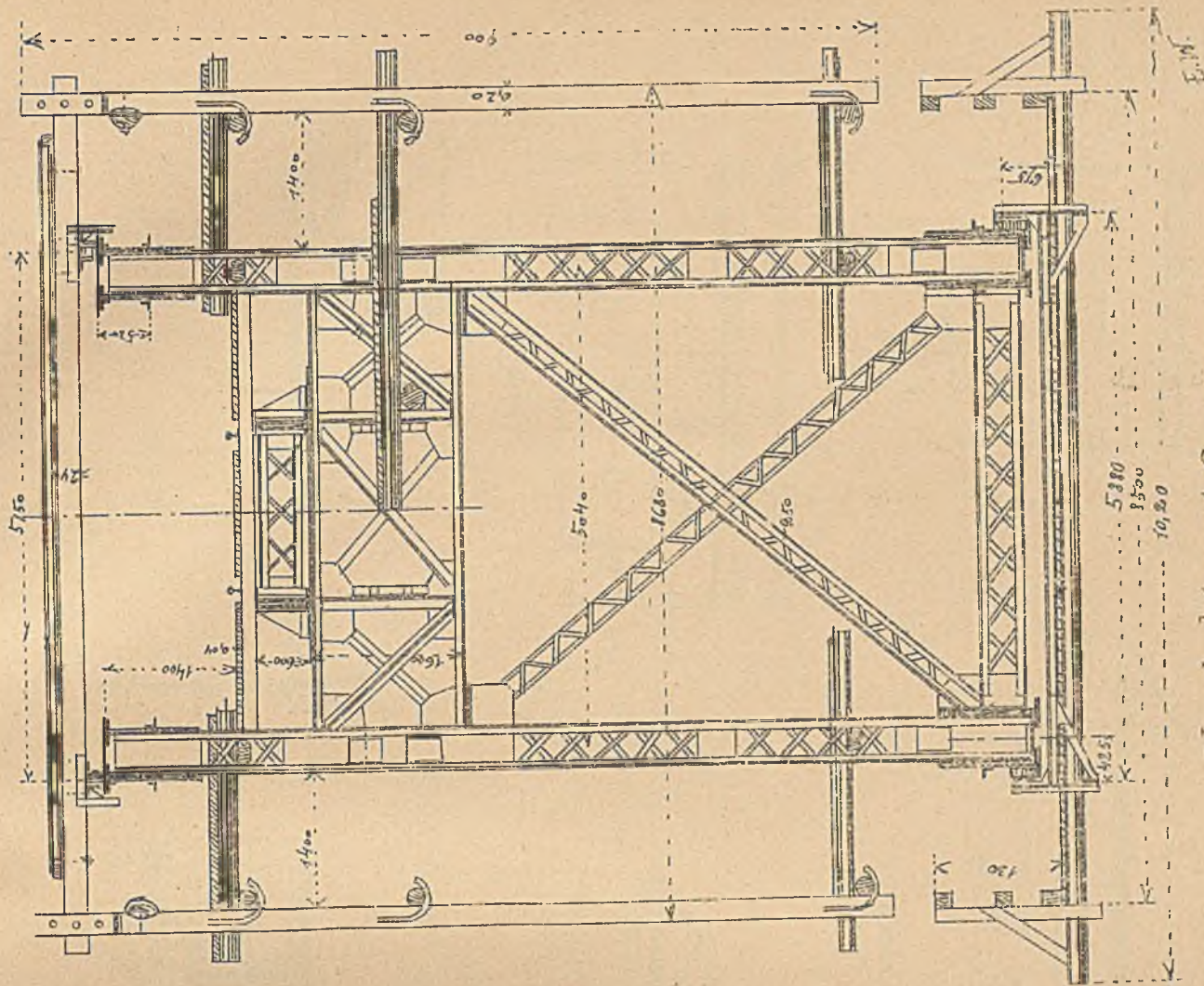

Wiadukt pod Czernowca.

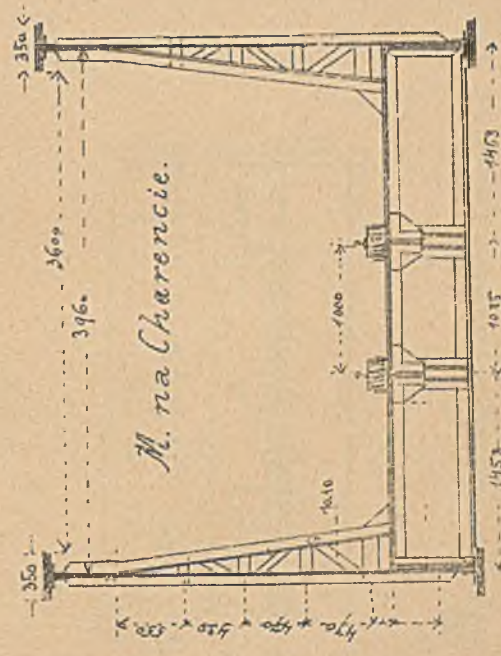

M. na Charente.

Dr. Thullie. Mosty krat. zel.

Przekrój poprzeczny mostu.

Tabl. 131.

rys. 7.

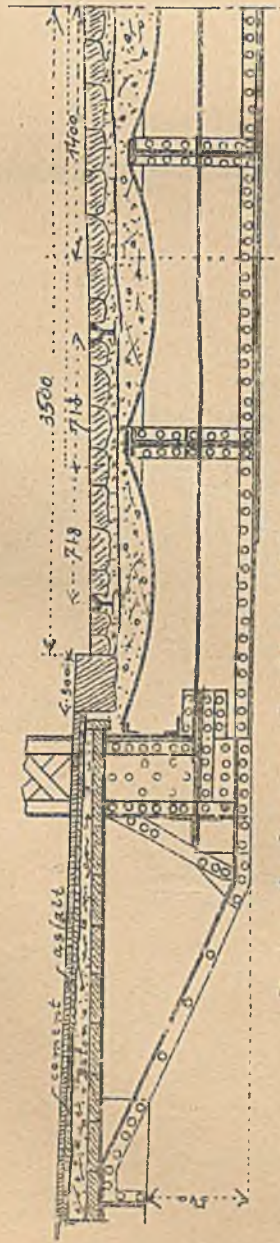

K. rz. Labie pod Hamburgiem.

rys. 1. Przekroje poprzeczne według austr. rozp. min.

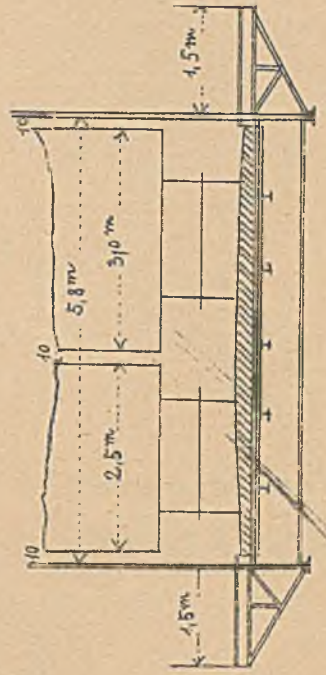

rys. 2.

rys. 3.



rys. 4.

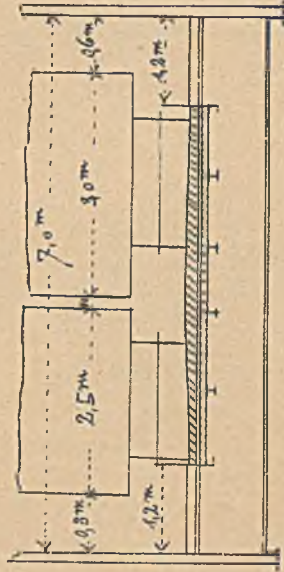

Dr. M. Thullie: Mosty kratowe żelazne.

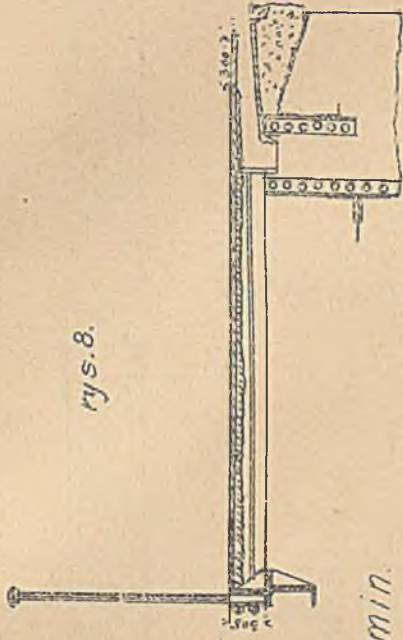

rys. 8.

rys. 5.



rys. 6.



I. N.

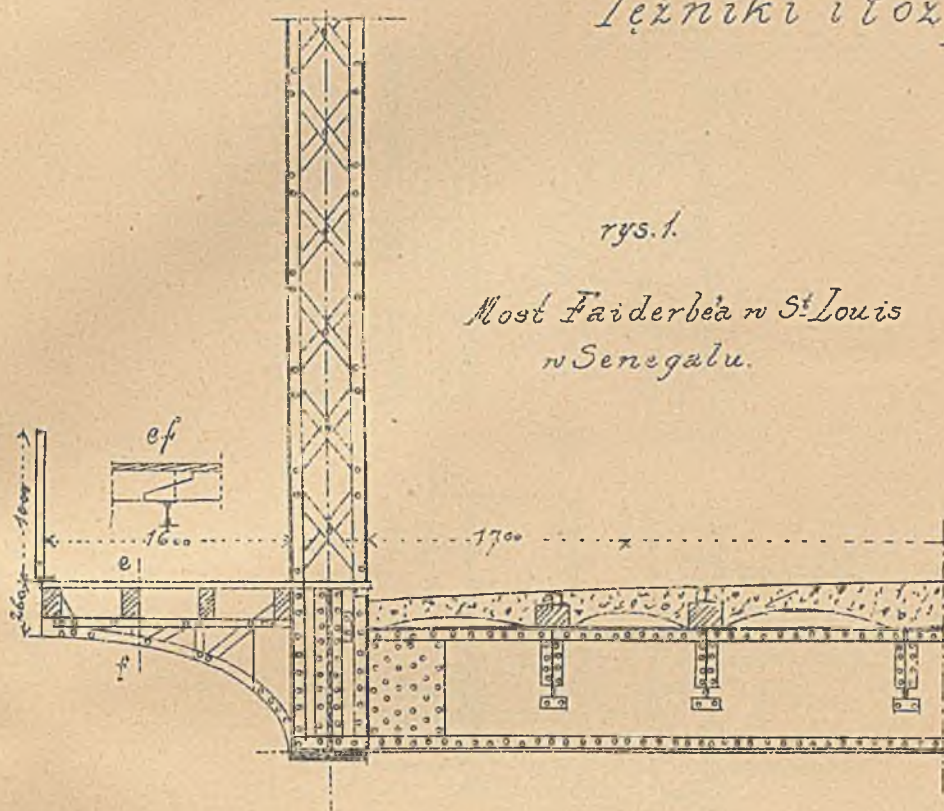

rys. 1.
Most Faiderbea w St. Louis
w Senegalu.

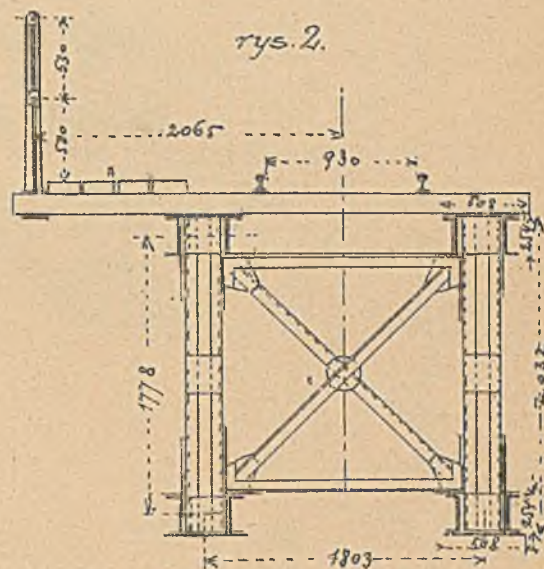

rys. 2.
M. kolei transandyjskiej.

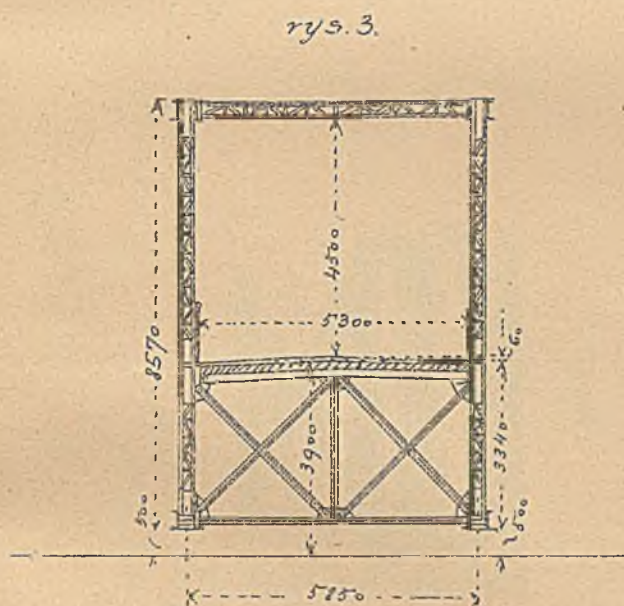

rys. 3.
M. na Trzebie pod Pontlatz.



rys. 4a
Trzebień.

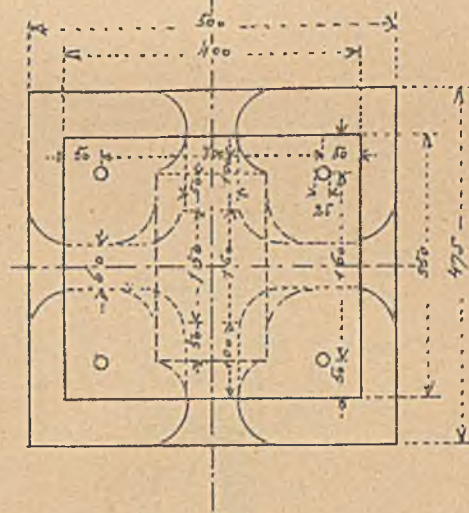

rys. 4b.

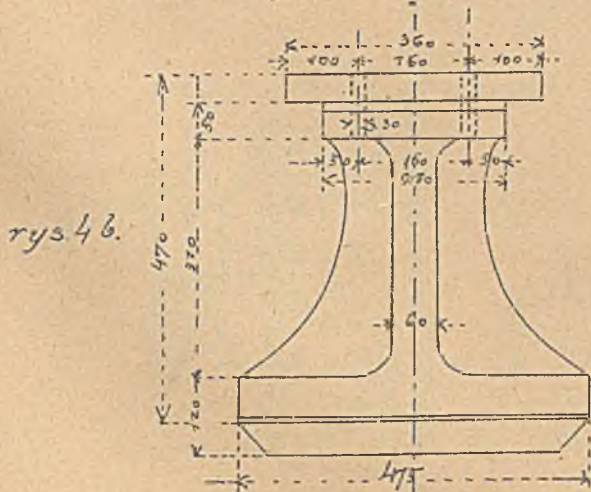

rys. 4c.

Łożysko mostu
na Charencie.

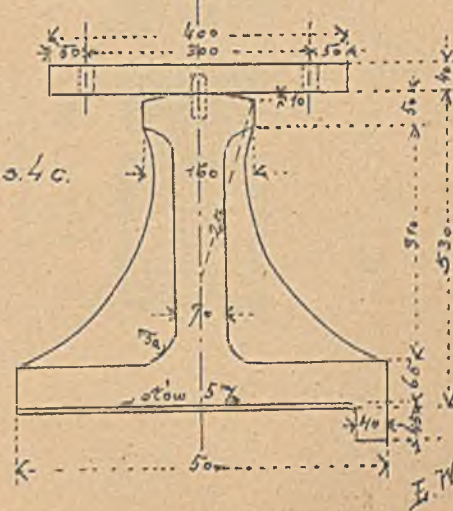

rys. 4d.

Łozysko.

rys. 1a.

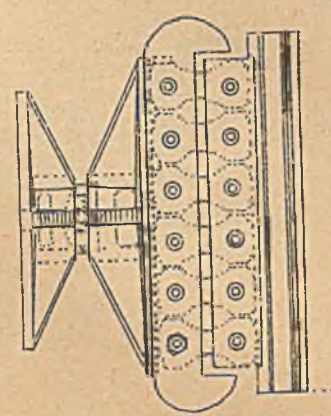

rys. 1b.

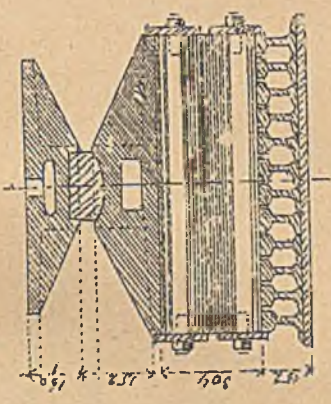

1:20.

rys. 1c.

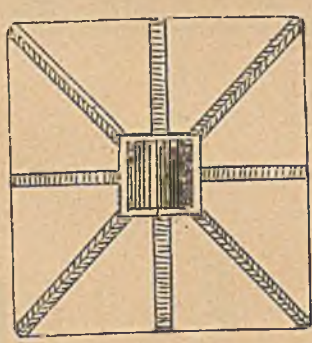

rys. 1d.



rys. 1f.



Łozysko:

ruchome.

rys. 3a, 3b.



state.

rys. 4a

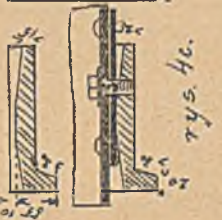

rys. 4b



rys. 4c.

M. na Okrzy w Braun schweig.

Dr. M. Thullie: Mosty krat. iel.

rys. 2a.

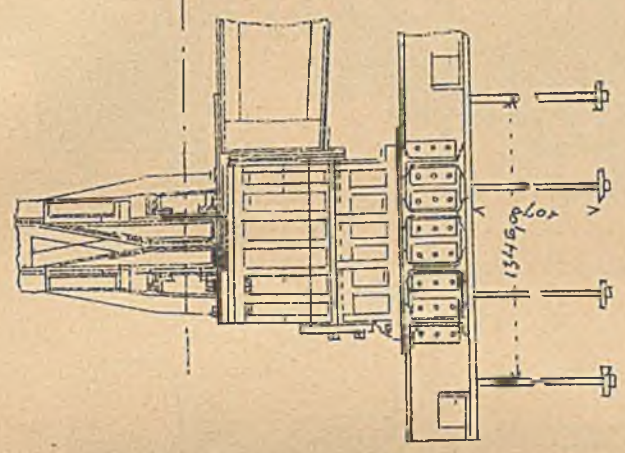

rys. 2b.

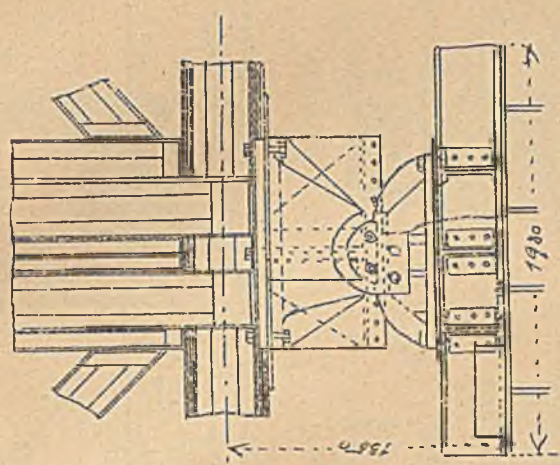

rys. 2c.

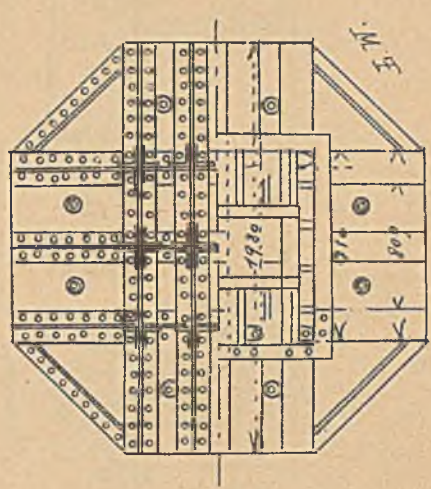

rys. 2d.



Most na Conway w półn. Walcs.

Łoxyska.

rys. 1a.

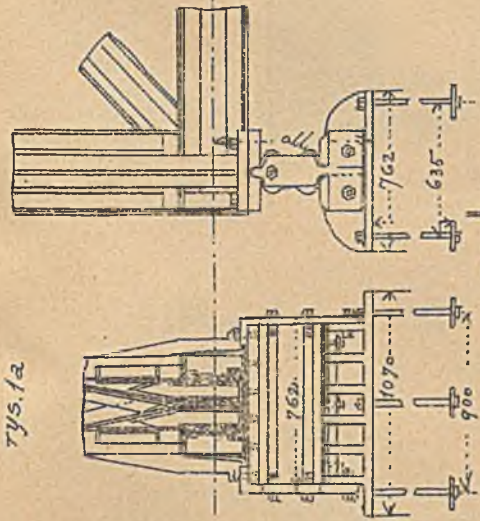

rys. 1b.

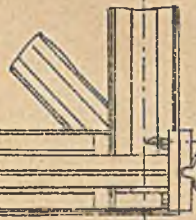

rys. 2a.

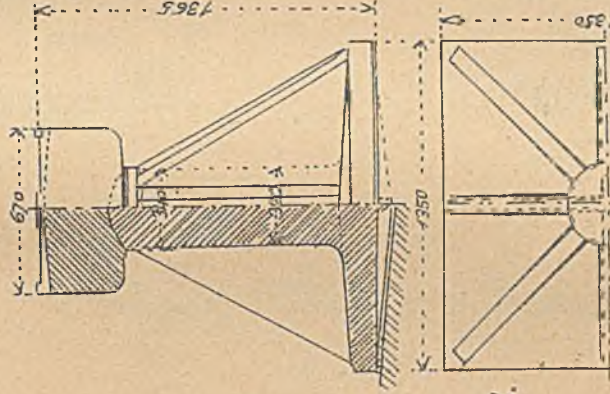

rys. 2b.

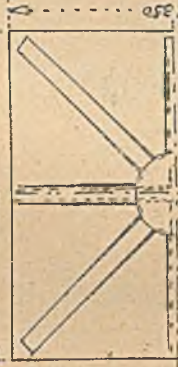

M. narzec Conway w póln. Wales.

rys. 1d.

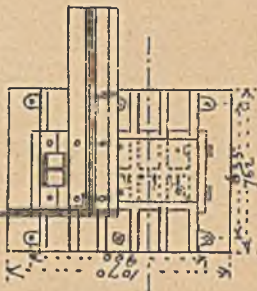

rys. 1c.



M. narzec pod Normacya.

rys. 4a.

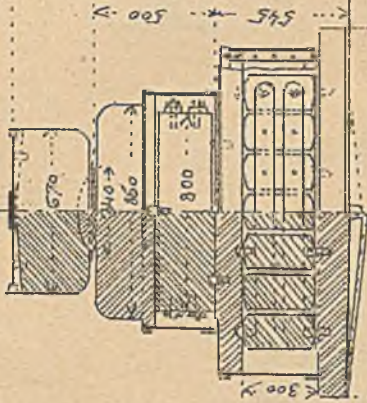

rys. 4b.

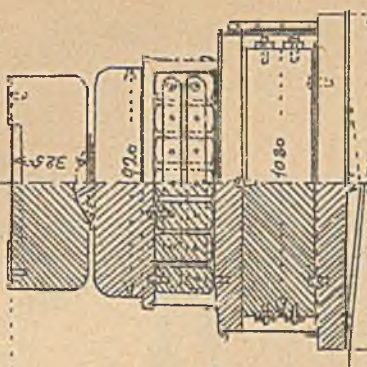

rys. 5a.

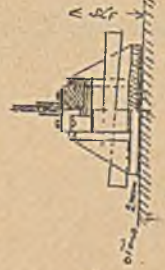

rys. 5b.

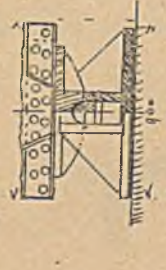

rys. 5c.



Most Karola kolo Stuttgartu.

rys. 6a.

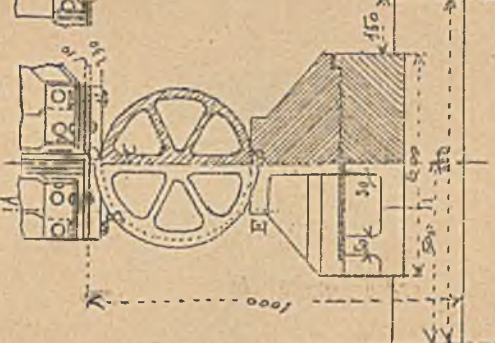

rys. 6b.

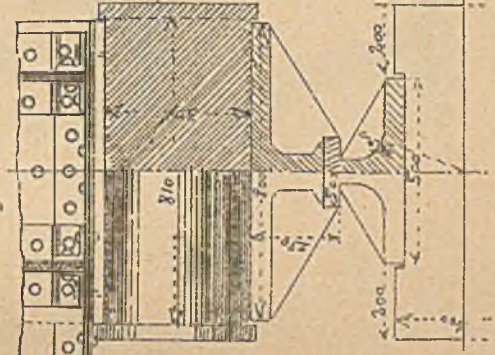

Dr. M. Thullie: Mosty krat. zel.

Most narzec Beuron.

rys. 7a.

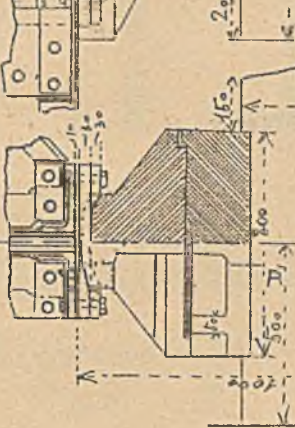

rys. 7b.



Рис. 1. Прелекоје попуеице.



Рис. 2. Мост в Дјецрине на Сабје.

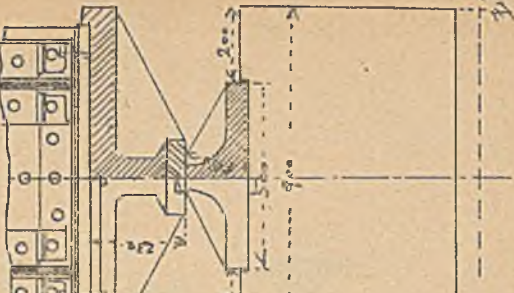

Рис. 3. Мост колеи зимтемберскеј на Дунају под Сигмаринген 1:50

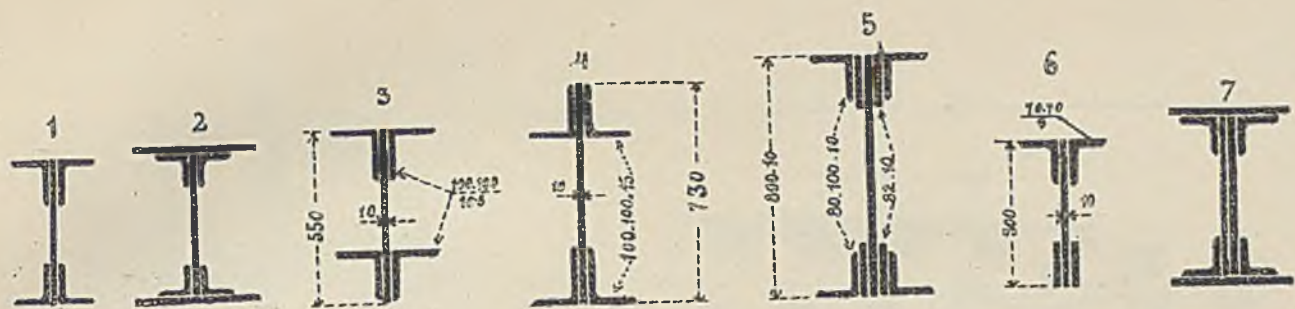

Рис. 4. Мост на Сааре в Салвигу.

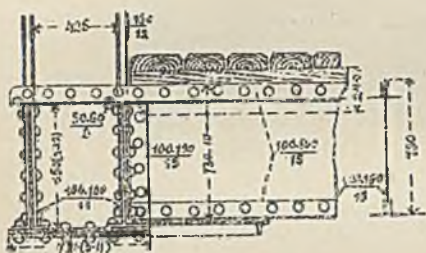

Рис. 4 а.

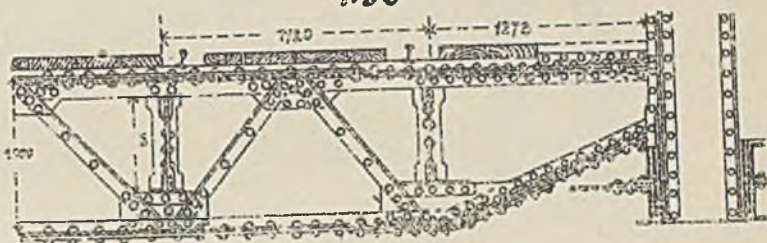

Рис. 5. Прелекоје паров попуеице лератом

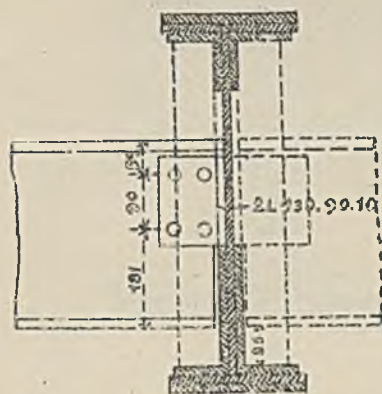
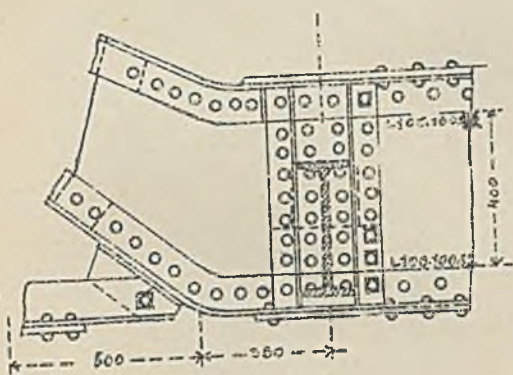

Рис. 7

Rys. 1. Urządzenie przeciw wykołajeniu się imi. Posta.

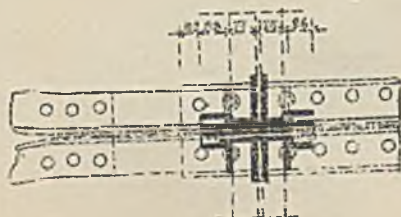
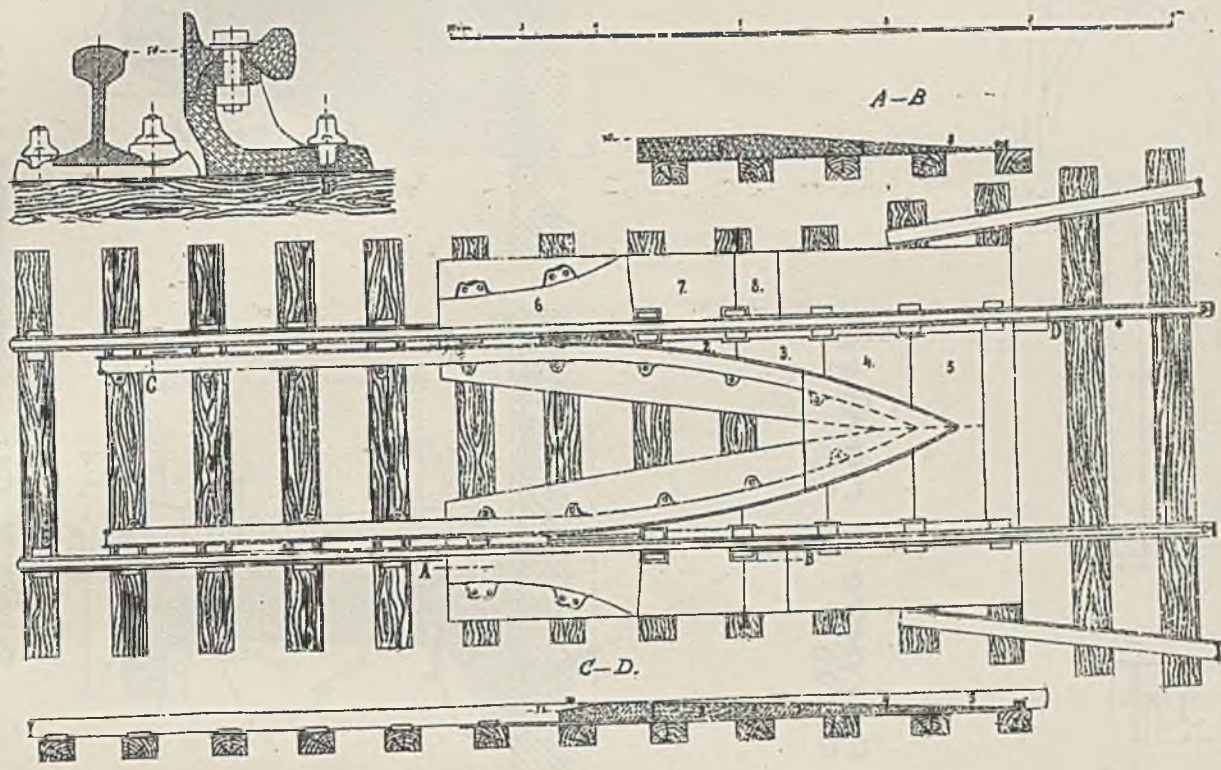

Rys. 2. Szyt wierdrenie podłumnic mostku na Renie s Koblencyi

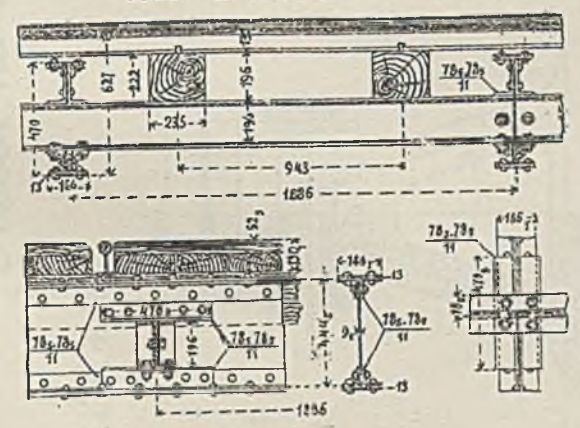

Rys. 3. Most na Menie pod Westha 1:50

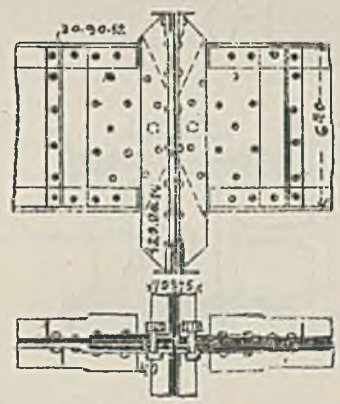

Rys. 3 a.

Rys. 4. Ułożenie podłumnic na moście na Ochrygu Łatcu.

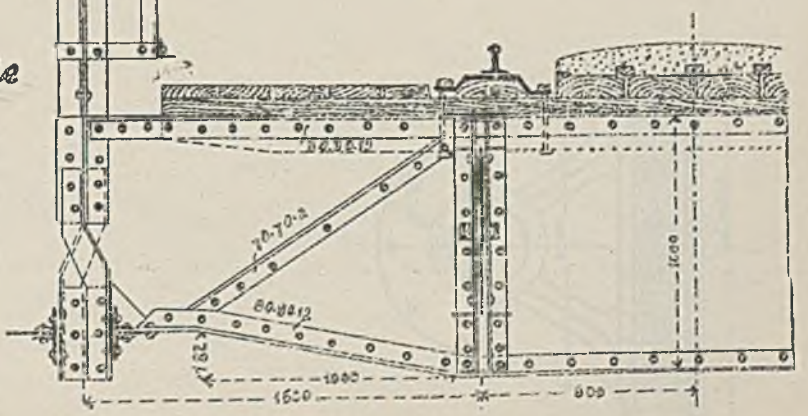
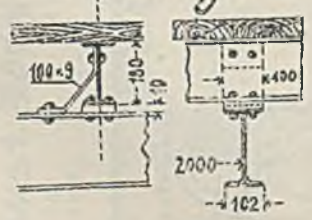

Ustrój poprzecznic i techników.

rys. 1. Most drogowy w Lucernie. l=220 m.
(rys. 1, 2)

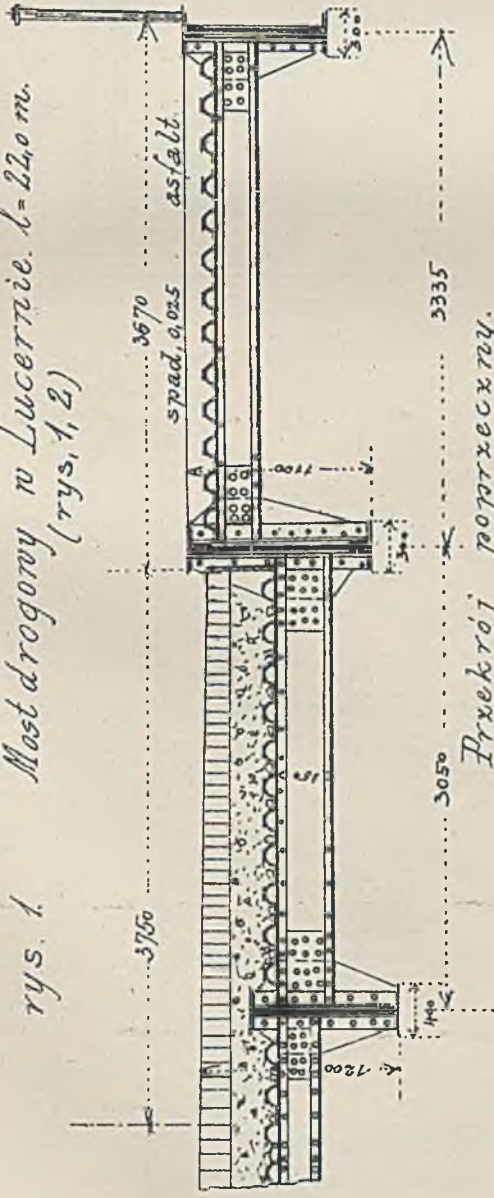

Przekrój poprzeczny.

Podziałka 1:50

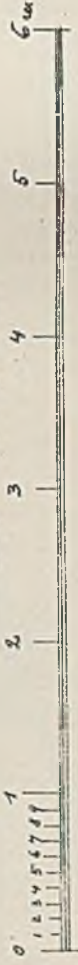

rys. 2.

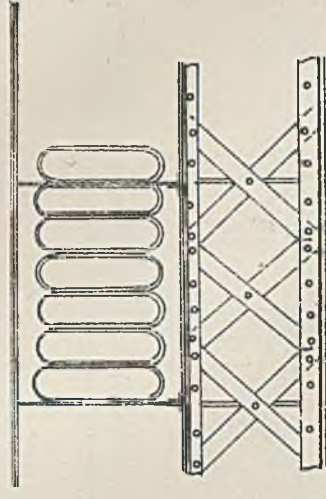

Belka chodniowa i poręczce.

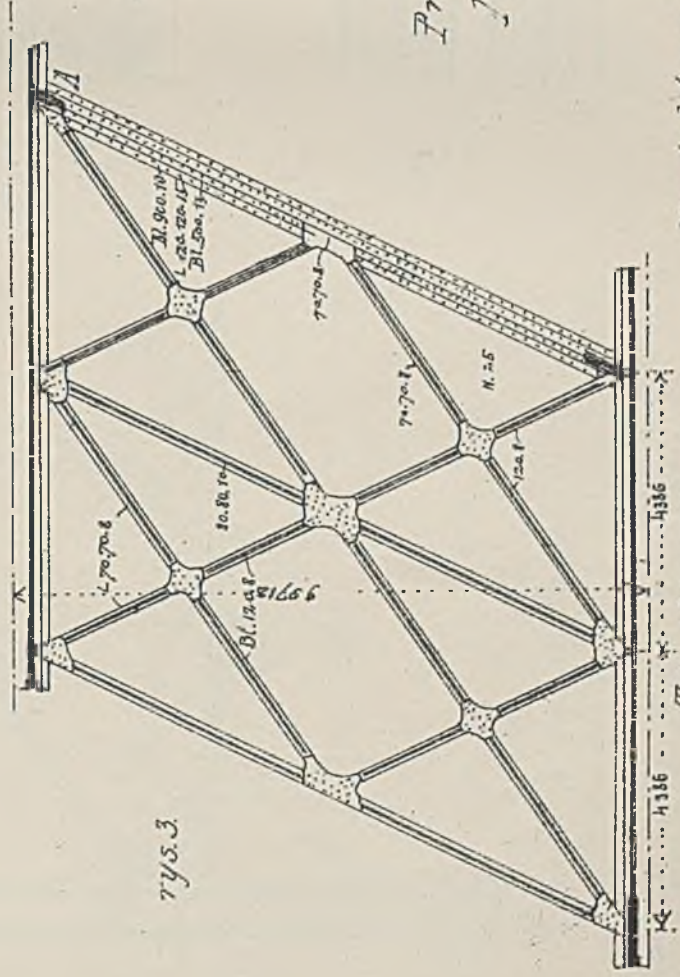

rys. 3

Techniki poziome.

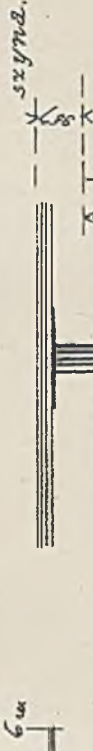

rys. 4

Szczegół A.

rys. 5

Przekrój pionowy.

Miadukt na Sekwanie w Paryżu. r. 3-5.

Most drogowy na Neckarze pod Mannheim.

rys. 1.

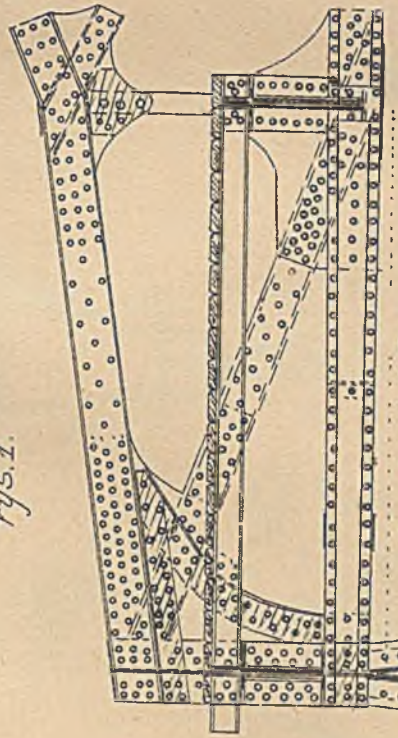

Przekrój A-B.

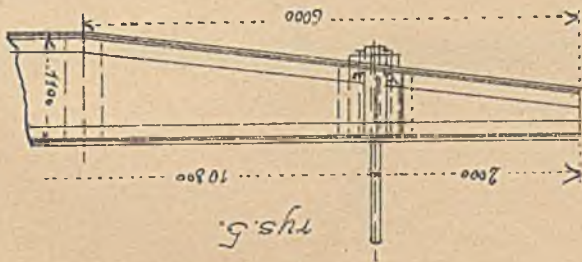

rys. 5.

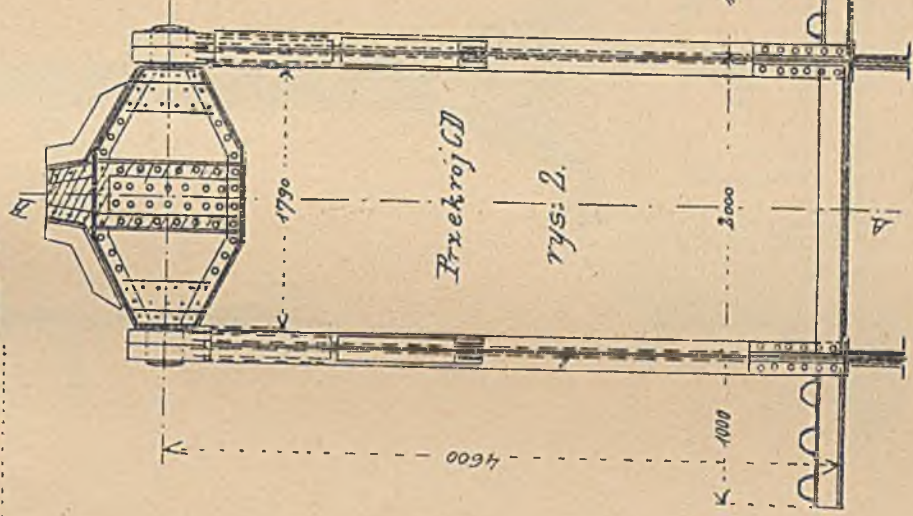

Przekrój C-D.

rys. 2.

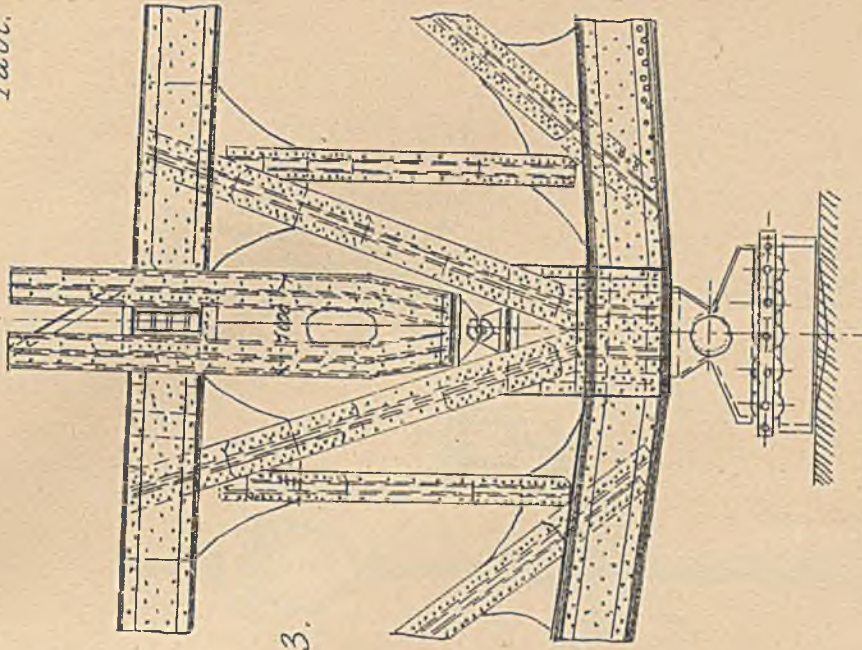

rys. 3.

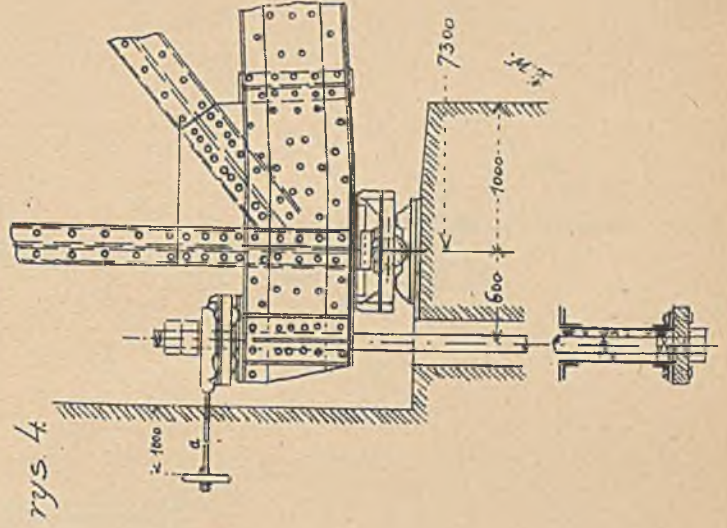

rys. 4.

Dr. M. Thullie: Mosty krat. żel.

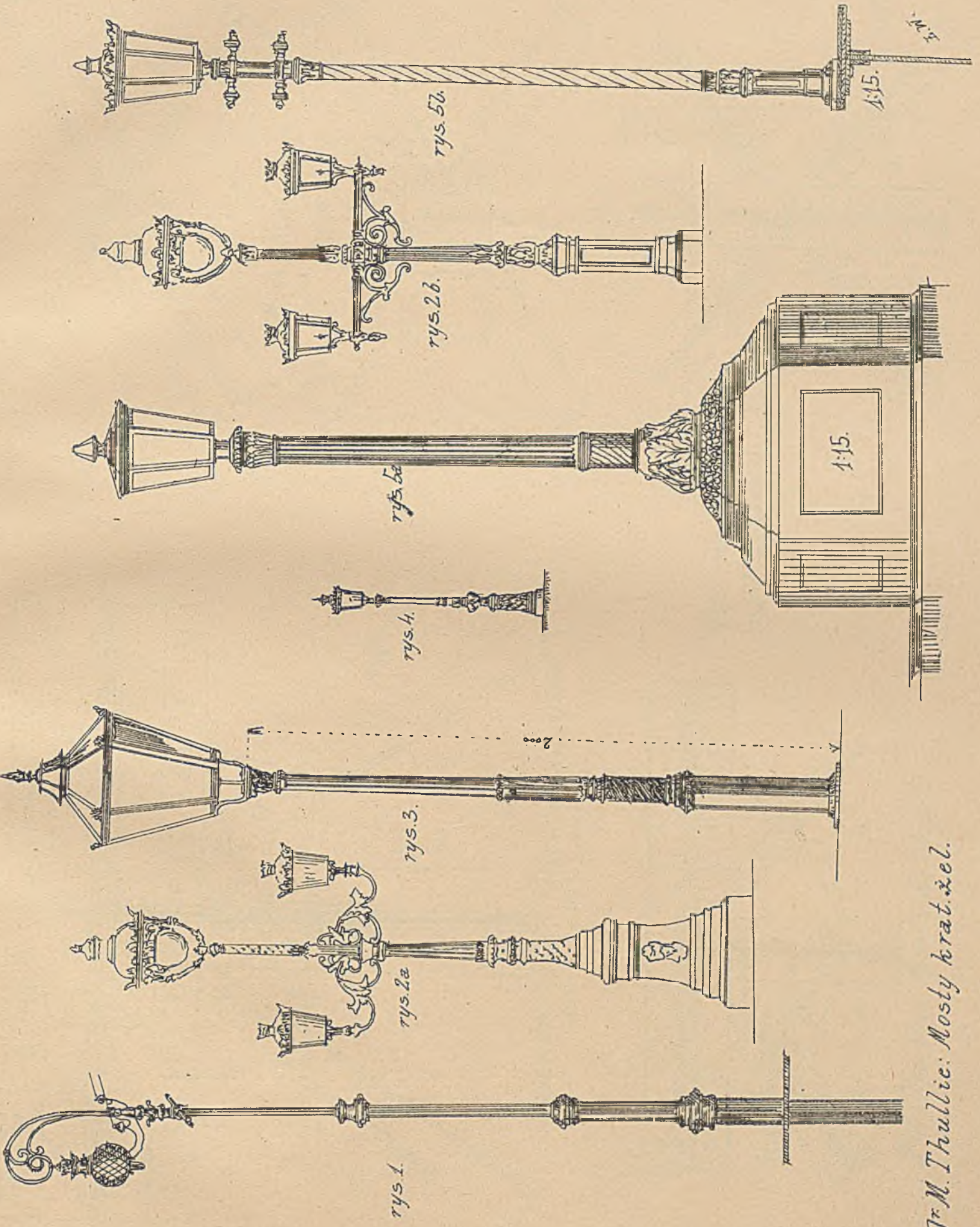

Dr. M. Thullie: Mosty krat. iel.

Skrzyżowanie się łożników poziomych.

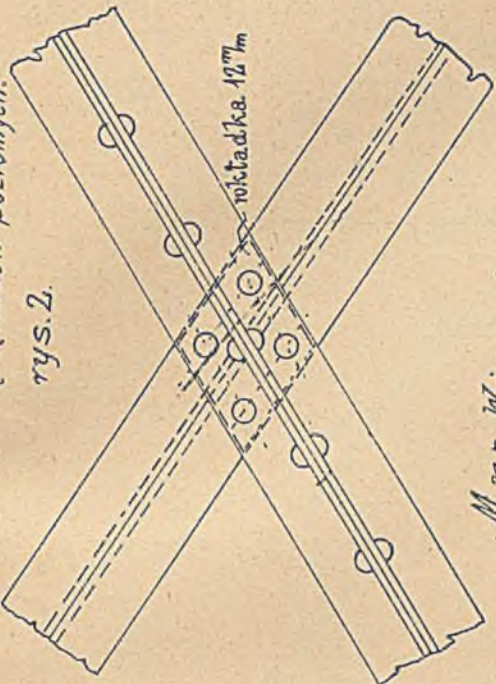

M. na Wiszni.

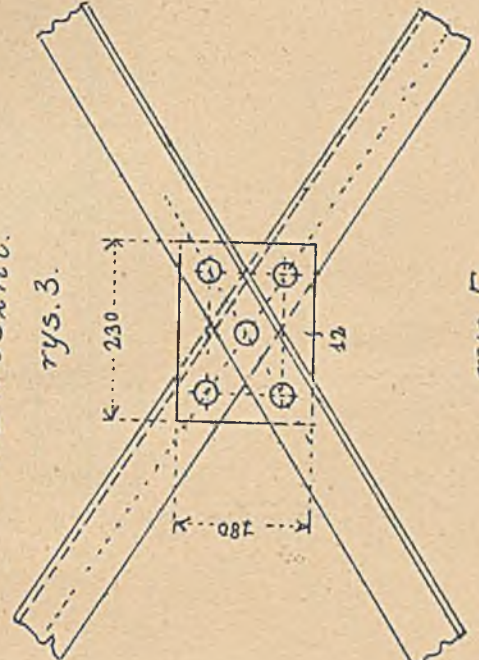

rys. 5.

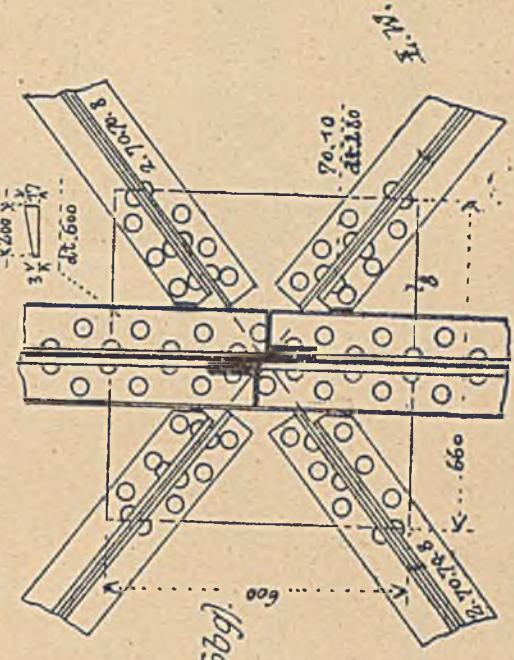

Most na Malcie pod Gmünd. (Sbg).

rys. 1

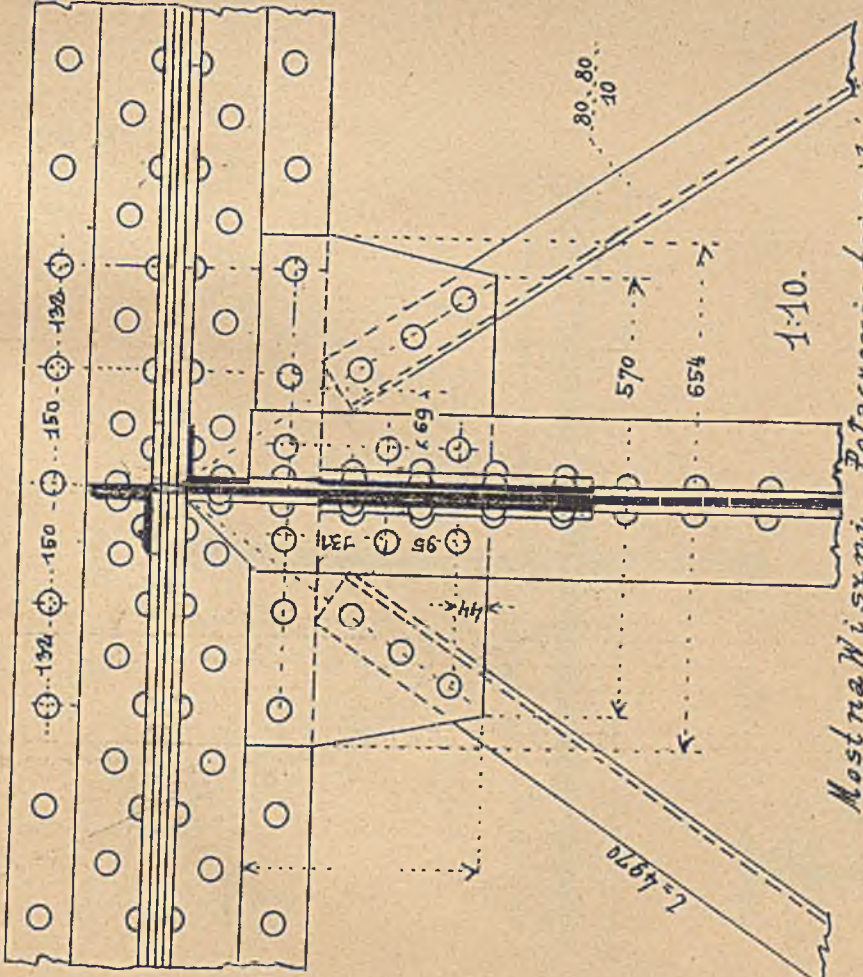

Most na Wiszni. Połączenie łożników poziomych x pionow.

rys. 4.

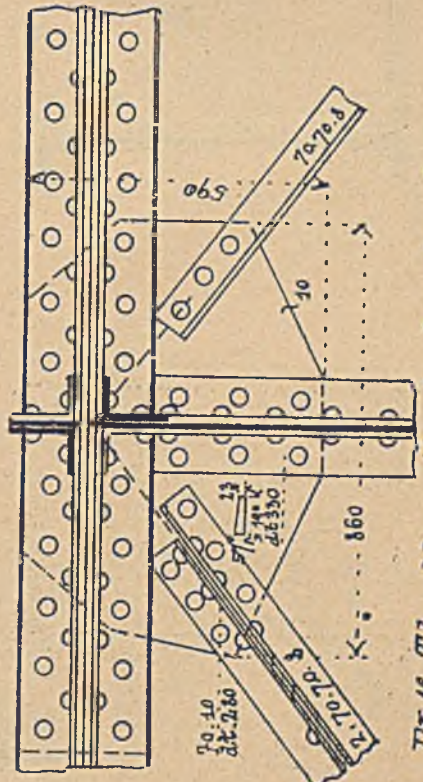

Dr. M. Thullie: Mosty krat. xcl.

Polaczenia techniku.

rys.1.

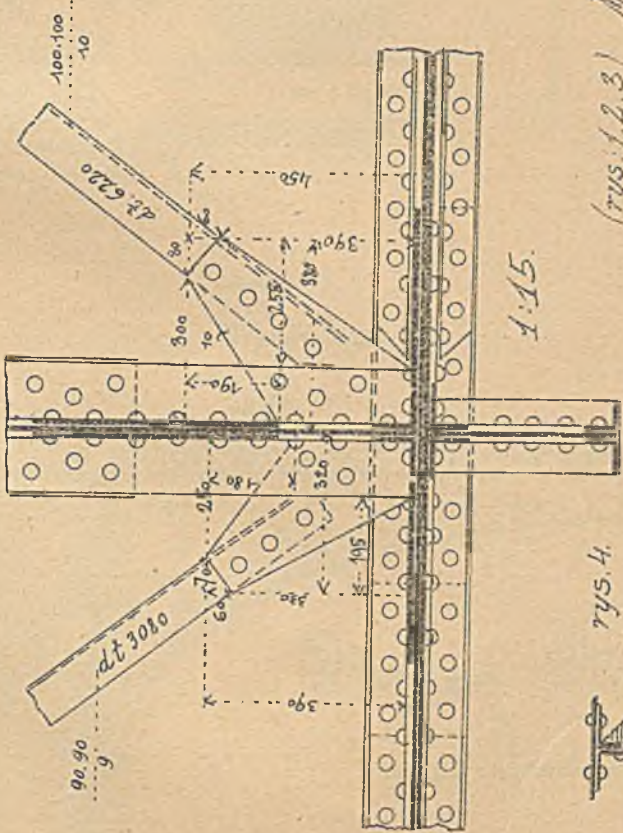

rys.4.

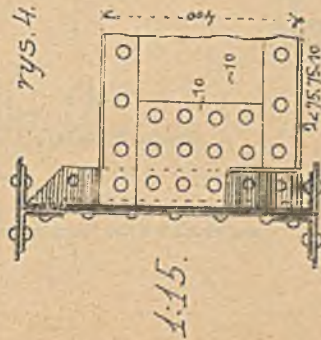

1:15.

rys.5.

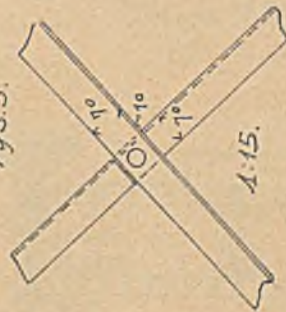

Most na Woltarwie.

Dr. M. Thullie: Mosty krat. iel.

rys.2.

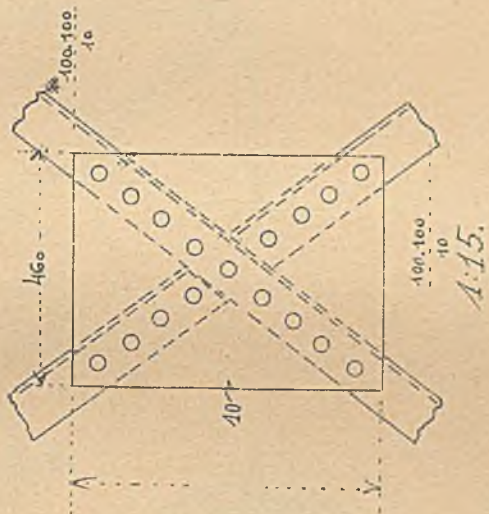

1:15.

rys.3.

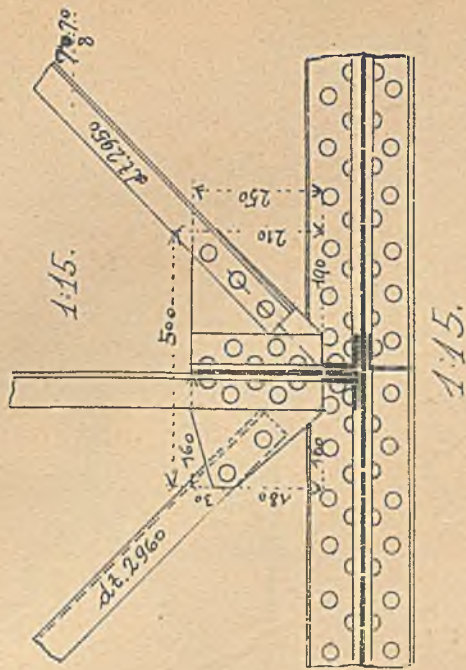

1:15.

Tabl. 143.

(rys. 1, 2, 3) Most na Woltarwie kolei transw. czesko-morawskiej.

rys.6a.

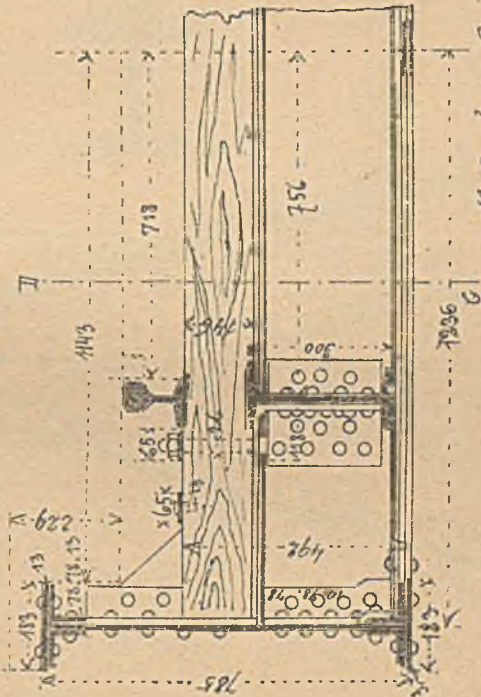

1:16.

M. kolei Scharxfeld-Nüxey.

rys.6b.

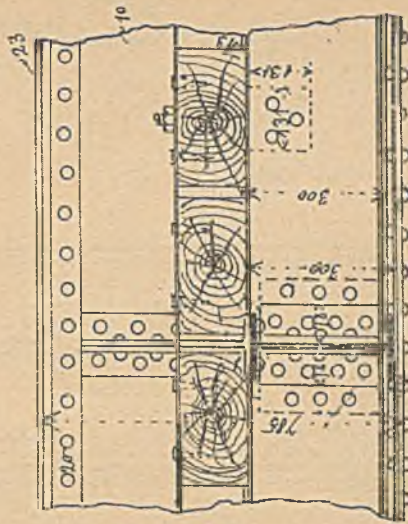

M. F.

Most na Garze pod Brzeg.

Rys. 1.

1:40

Rys. 1 a.

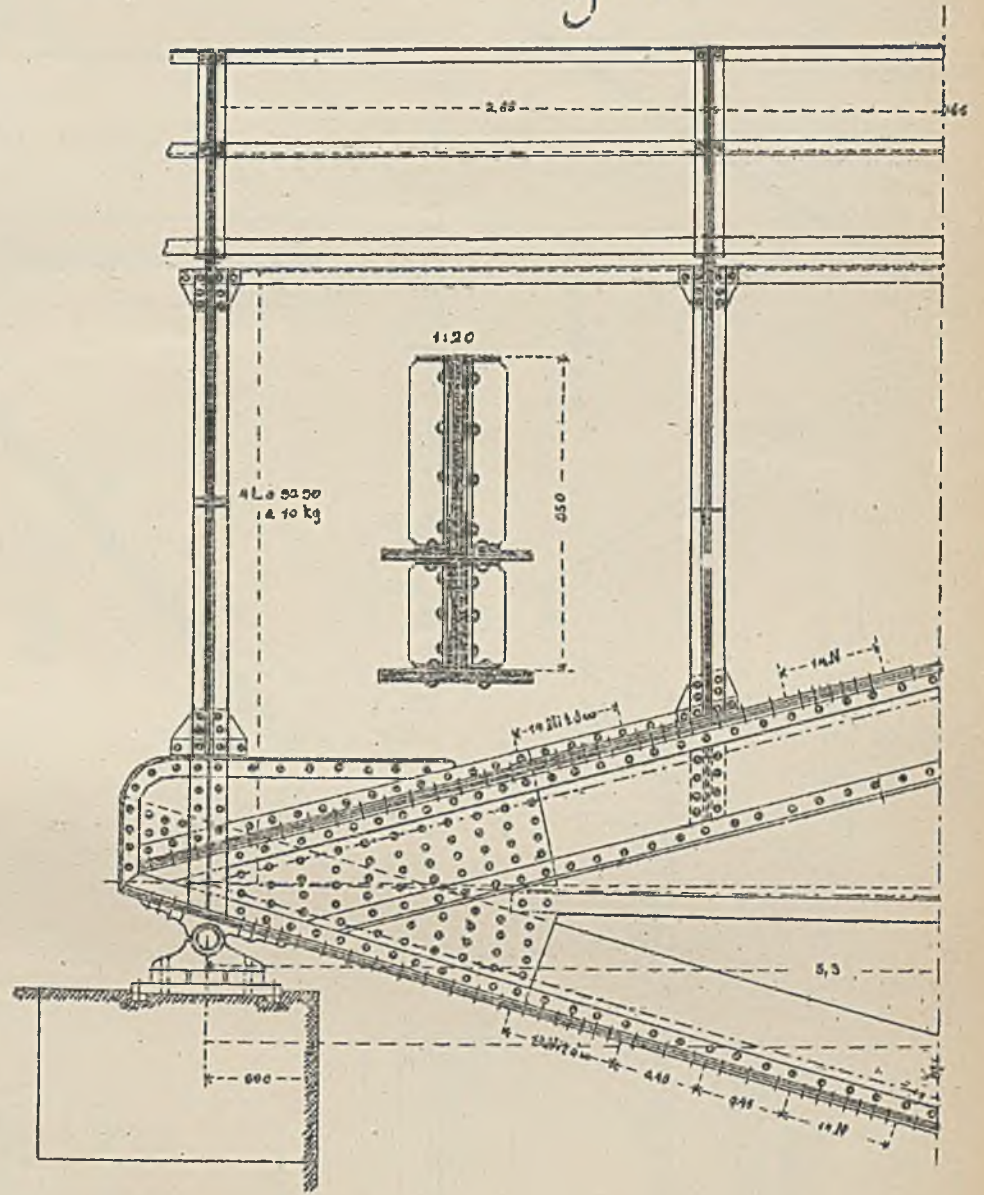
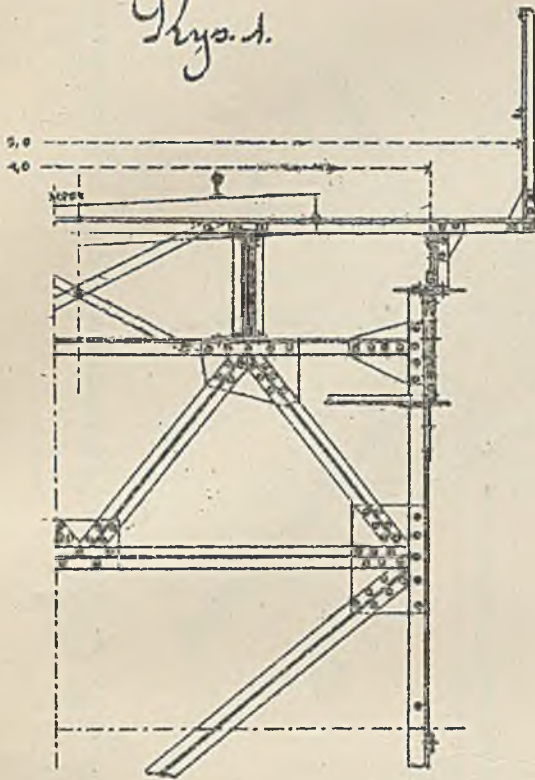

Rys. 1 p.

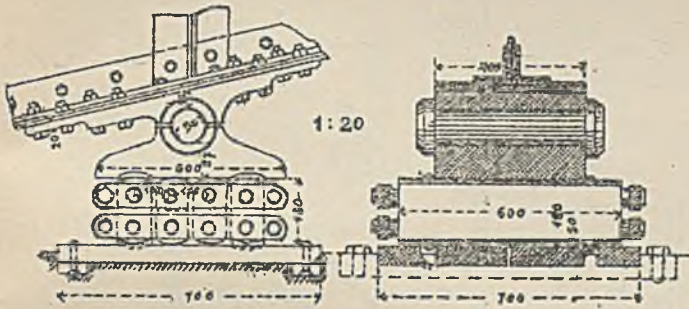

Rys. 2 a.

1:50

Rys. 2 b.

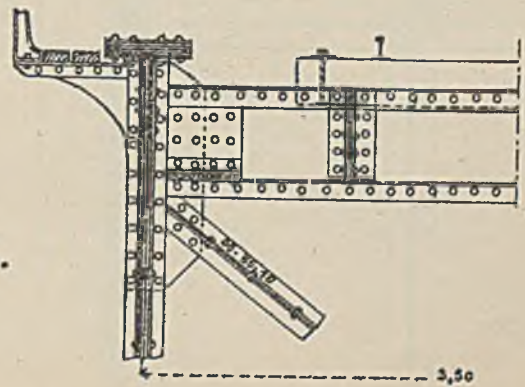
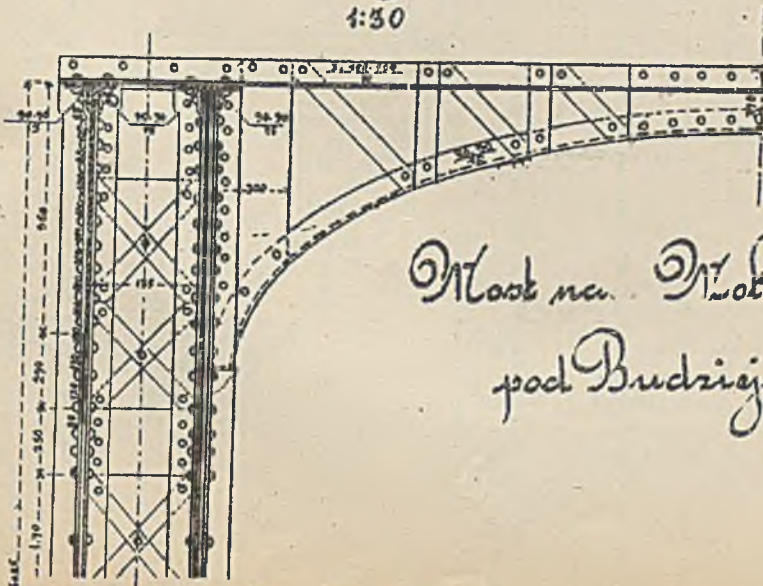

Most na Włodawie pod Budziejowicami.

Rys. 1. Polaczenie kolumnow poz. 7 pasem.

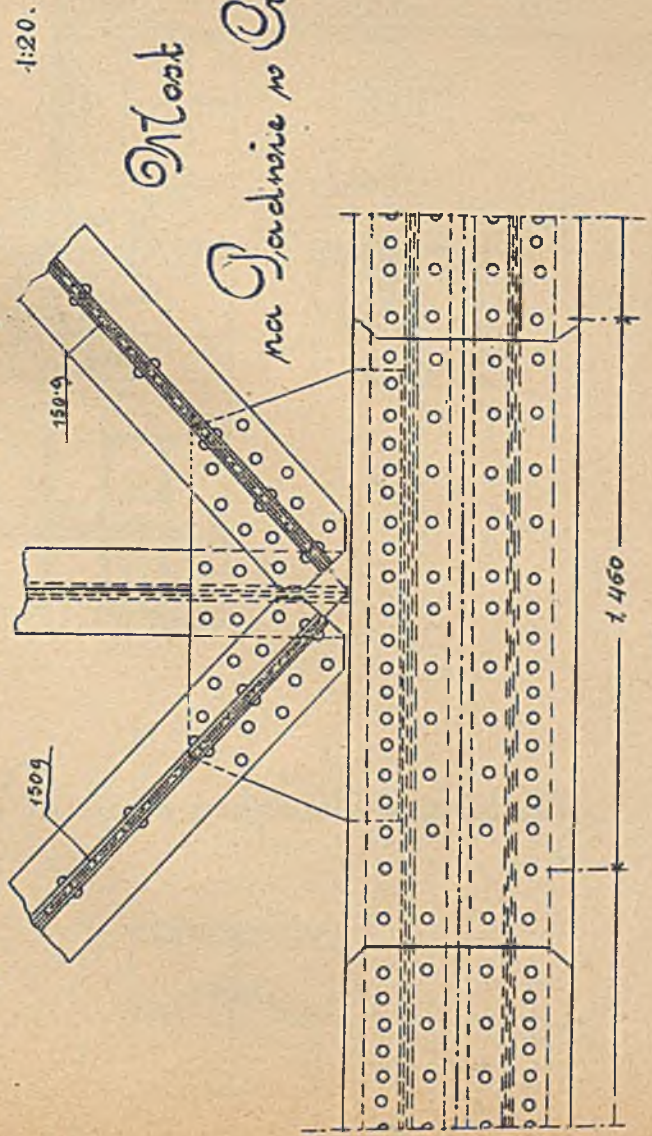

Rys. 2. Skrzyzowanie sie kolumnow.

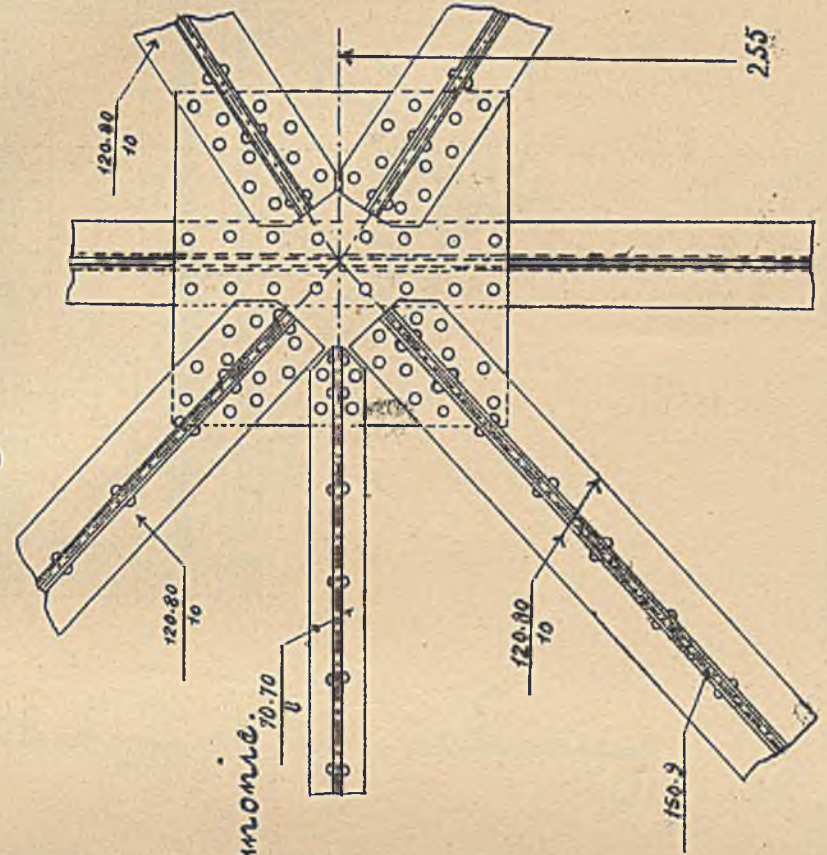

Rys. 3. Polaczenie kolumnow poz. 7 pasem.

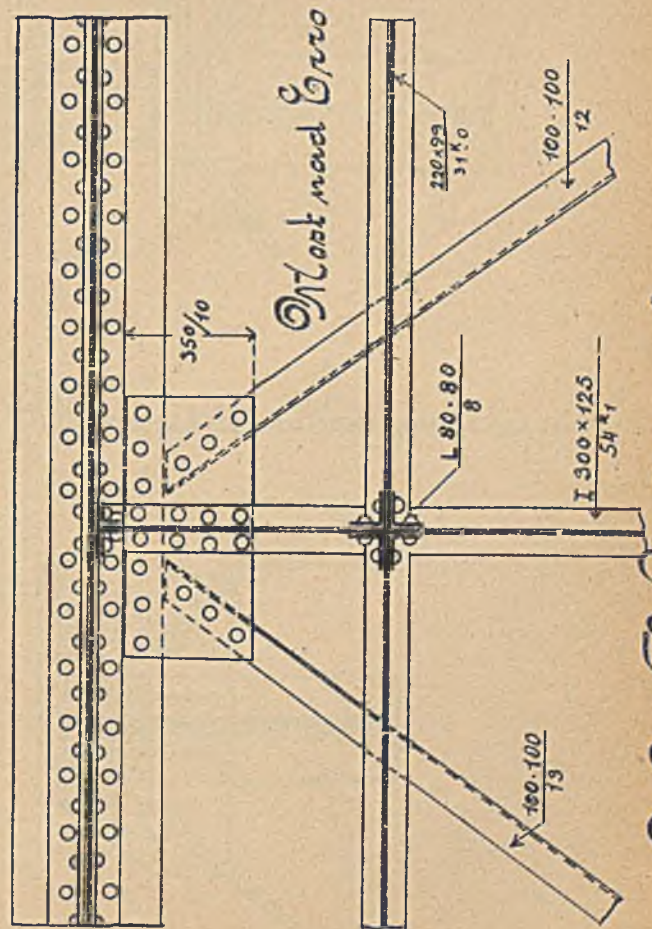

Rys. 4. Polaczenie kolumnow poz.

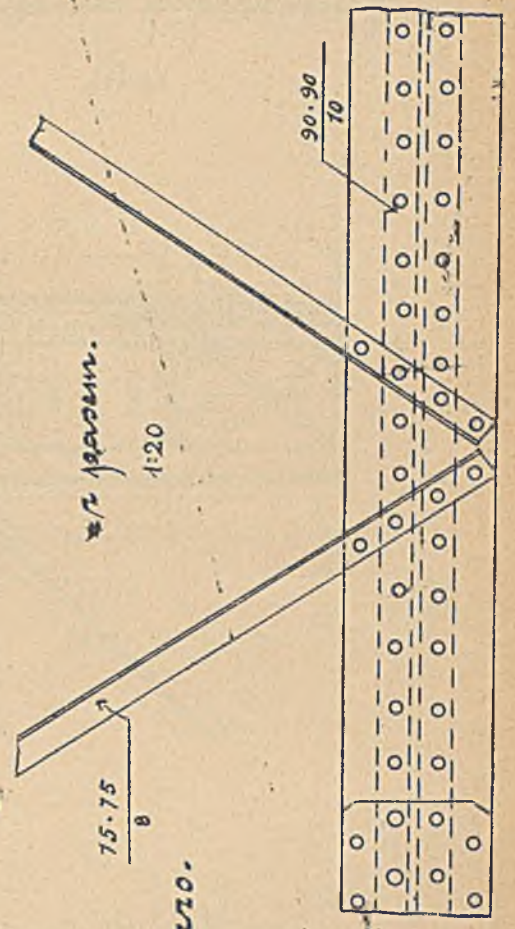

Rys. 1. Stojenie gora.

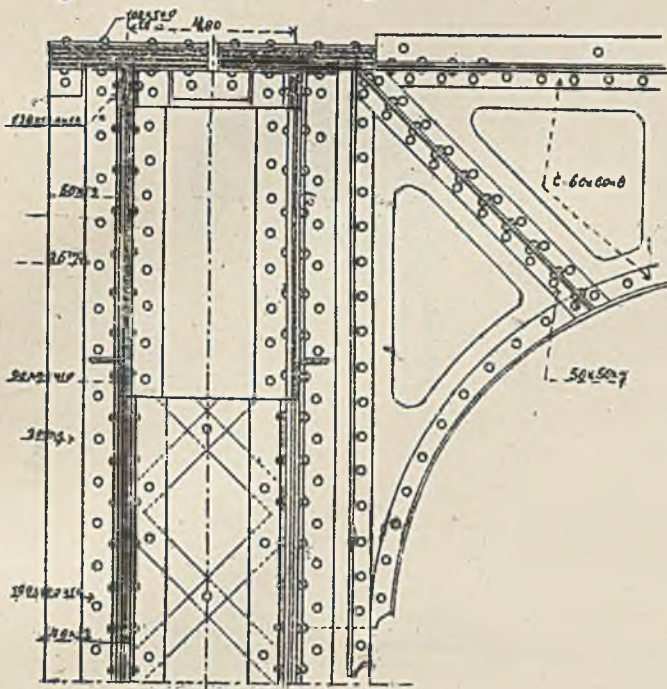

Rys. 2. Tiznik poprzeczny.

1:400.

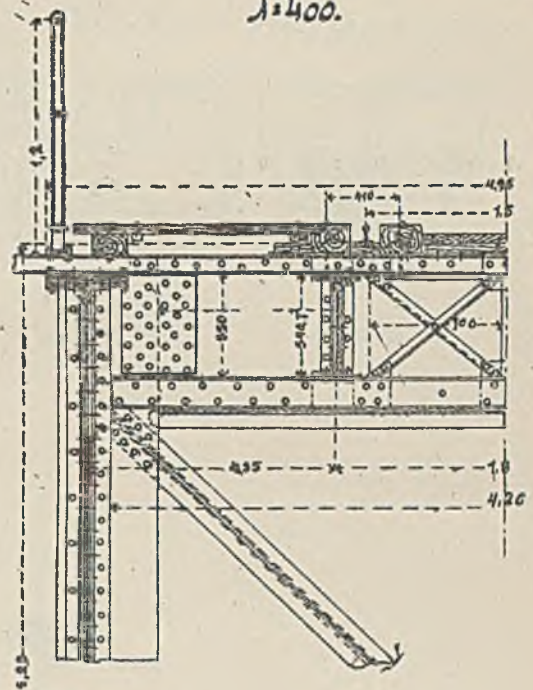

Rys. 3. Ruchome podparcie podbrzini.

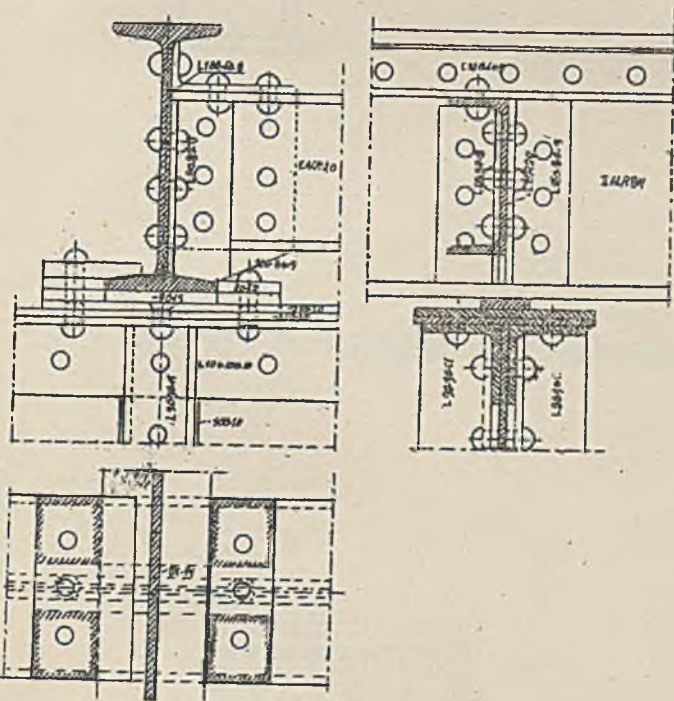

Rys. 4. Polaczenie kiznikow por.

z pracem.

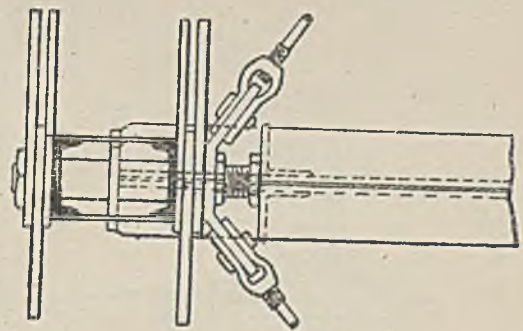

Rys. 6. Polaczenie kiznikow por. z pracami.

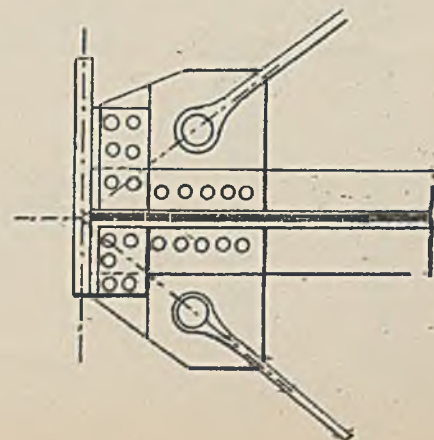

Rys. 5. Ruchome podparcie podbrzini.

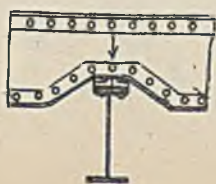

Przekroje poprzeczne i tozyska.

rys. 1 (1:40)

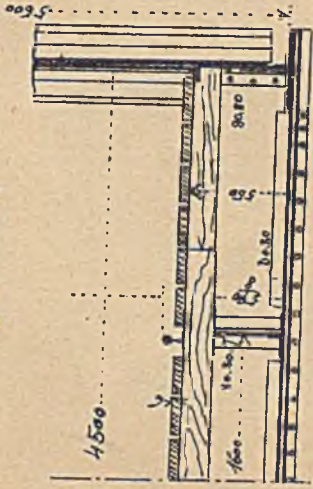

Most na Viede w Szwajcaryi.

rys. 2.

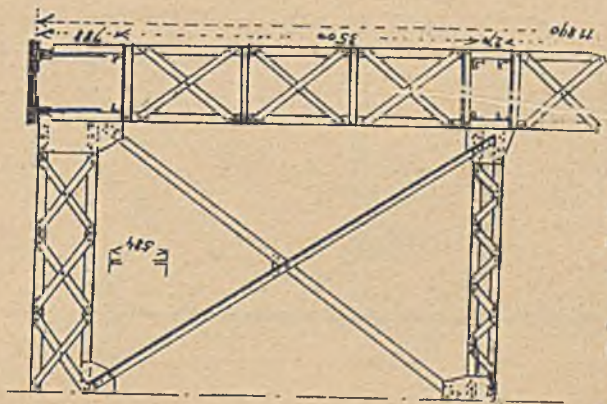

M. na Belai kol. Samara-Ufa.

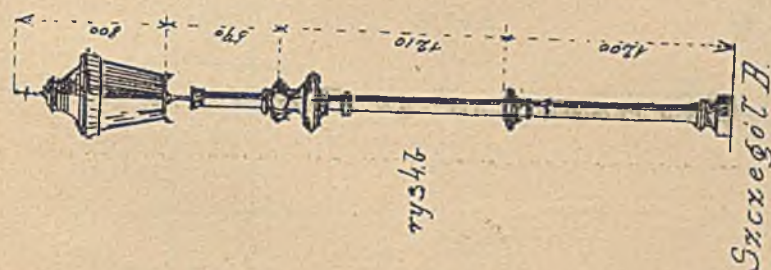

rys. 4b

Szczegół H

rys. 4.a

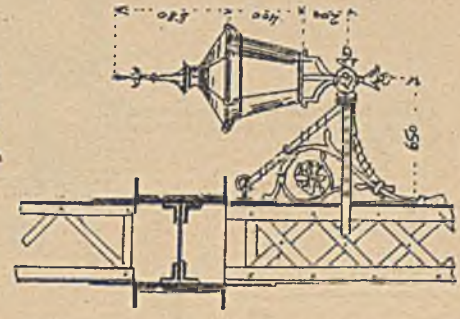

Szczegół A.

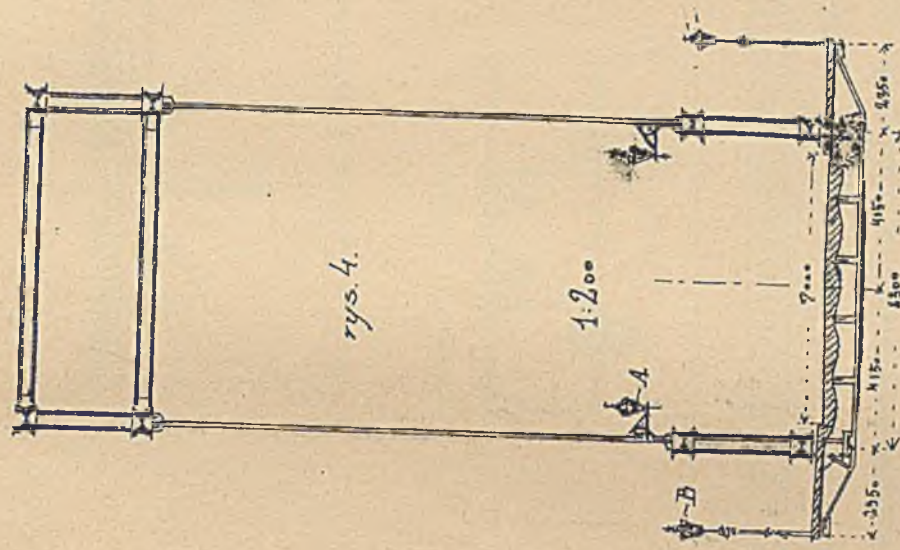

rys. 4.

M. na Labie p. Hamburgiem.

rys. 3.



M. na Dunaju pod

Szernawoda.

Przekroj technika. podobnego.

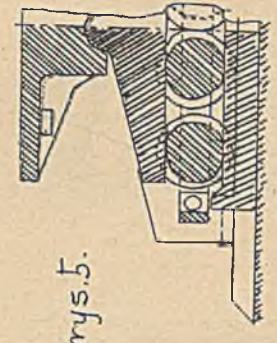

rys. 5.

M. kol. badeniskiej.

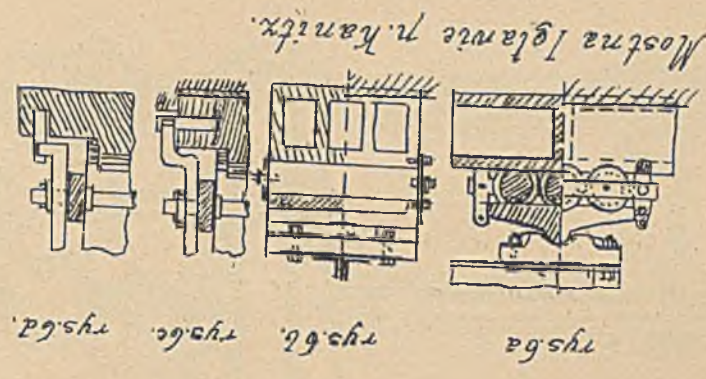

Mostna Iglanie p. Kanitz.

Dr. M. Thullie. Mosty i rat. zel.

POPZRZECZNICE

Rys. 1. Pomost ze żłobkowanej blachy na Wiśle w Tczewie.

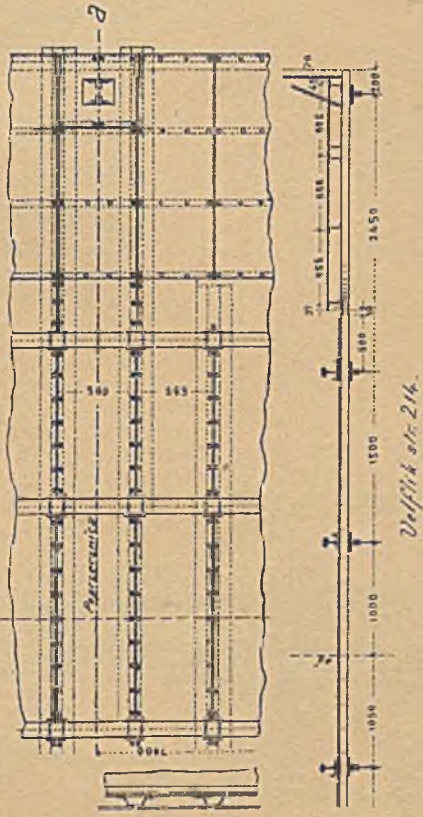

Rys. 2. Most na Renie w Moguncyi, 1300 w.

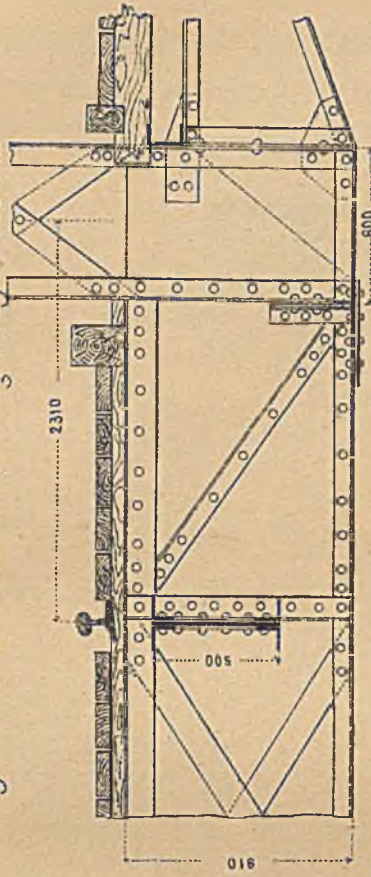

Rys. 1a. Szczegóły.

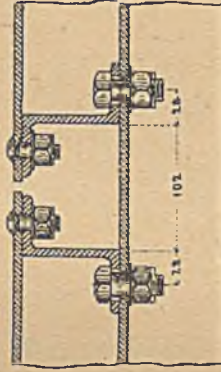

Rys. 3. Most ces. Franciszka Jozefa na Wełławie w Pradze.

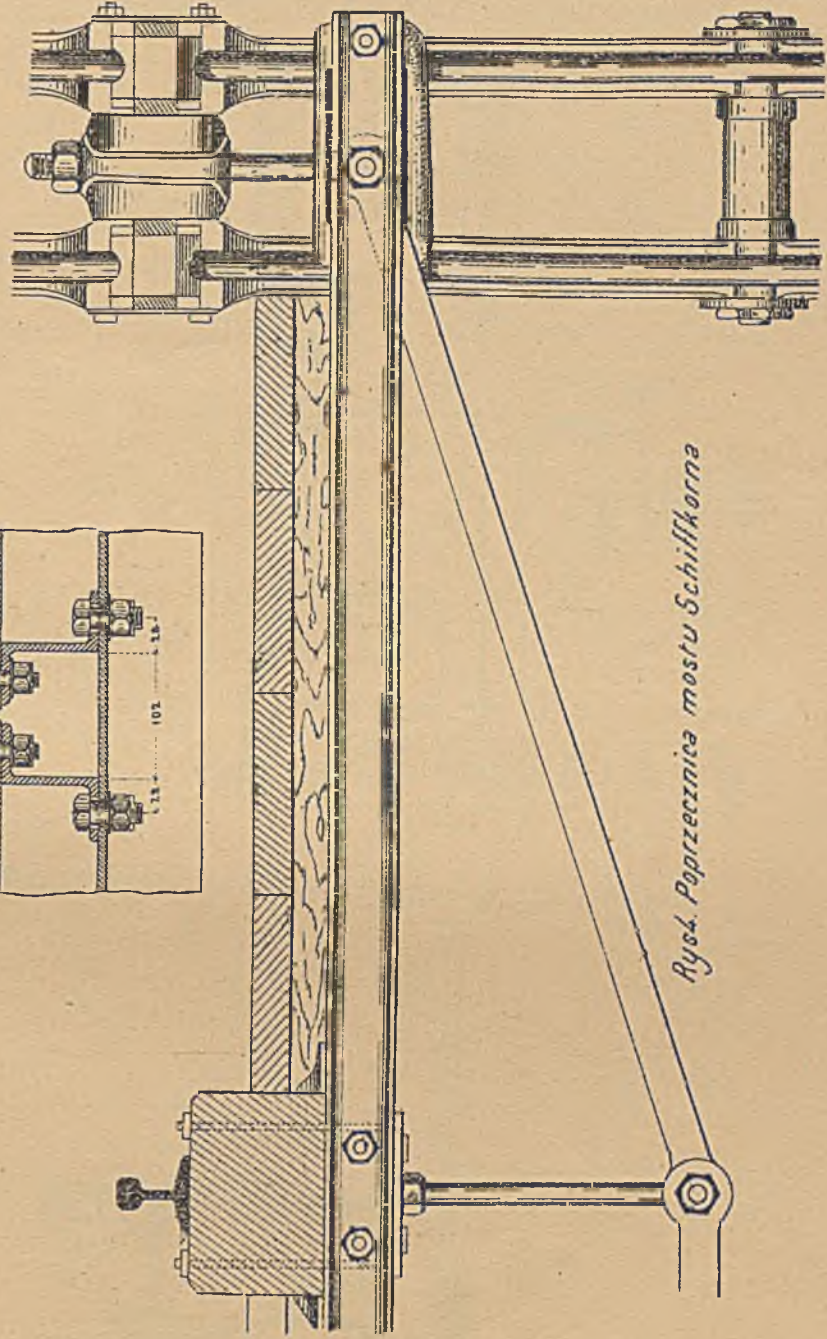
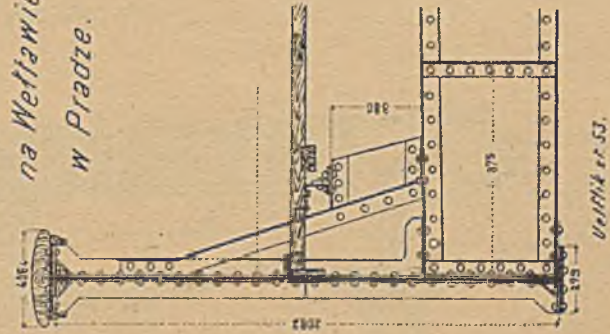

Rys. 4. Poprzecznicza mostu Schiffkorna

UTWIERDZENIE POPRZECZNIC

Rys. 2. Most na Wolesce w Kosztarowie.

Rys. 1. Przymocowanie poprzecznice mostu na Dunaju w Kremsie.

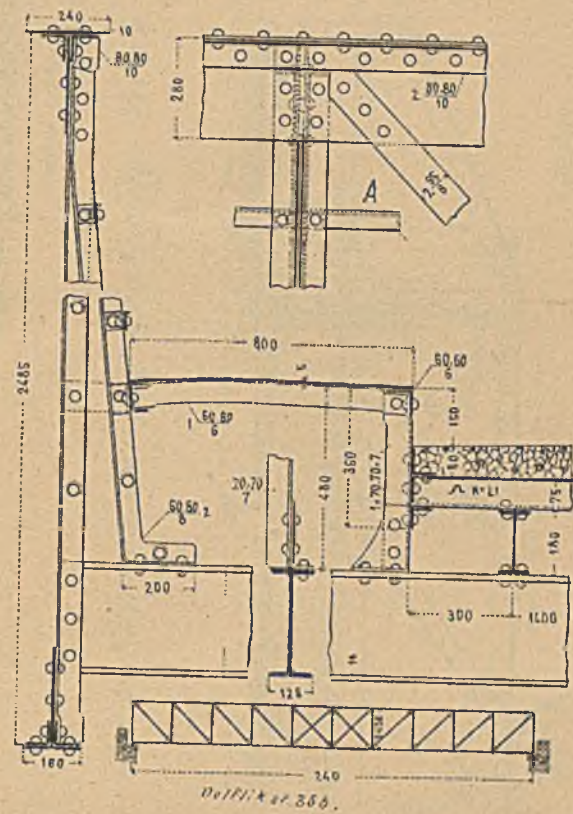
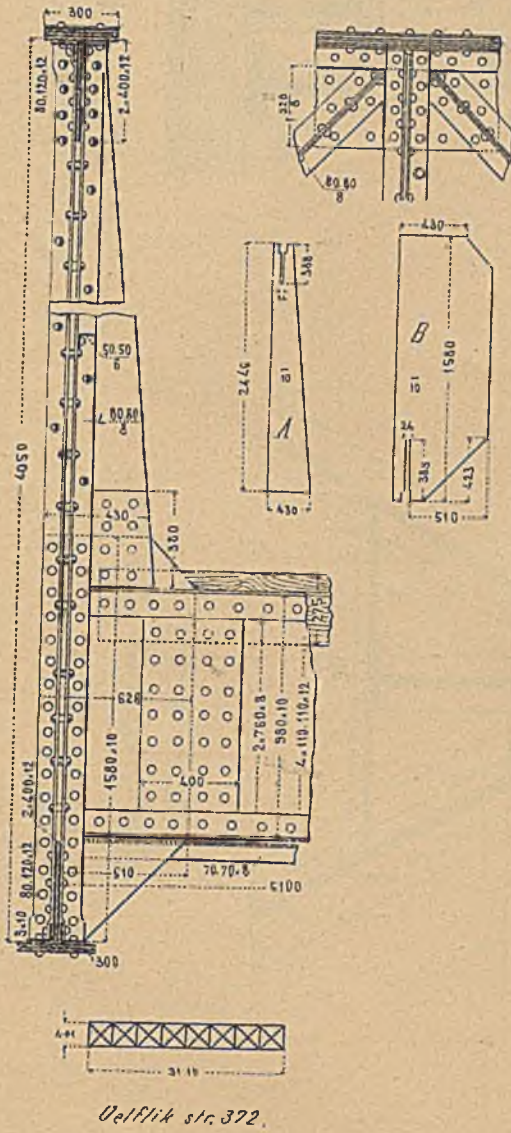

Rys. 3. Most na Dunaju pod Sigmaringen.

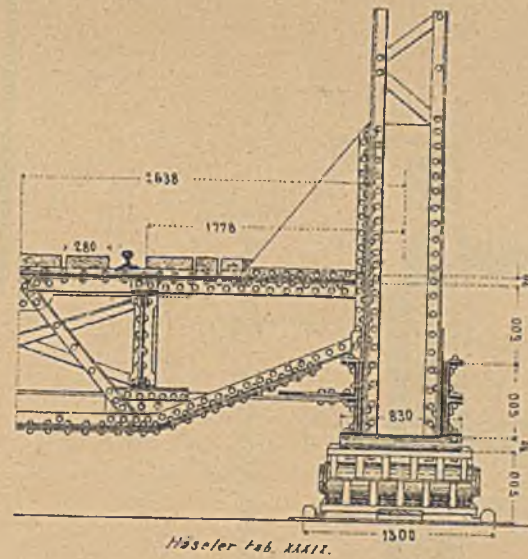

Rys. 4. Wiadukt Lengelfeld.

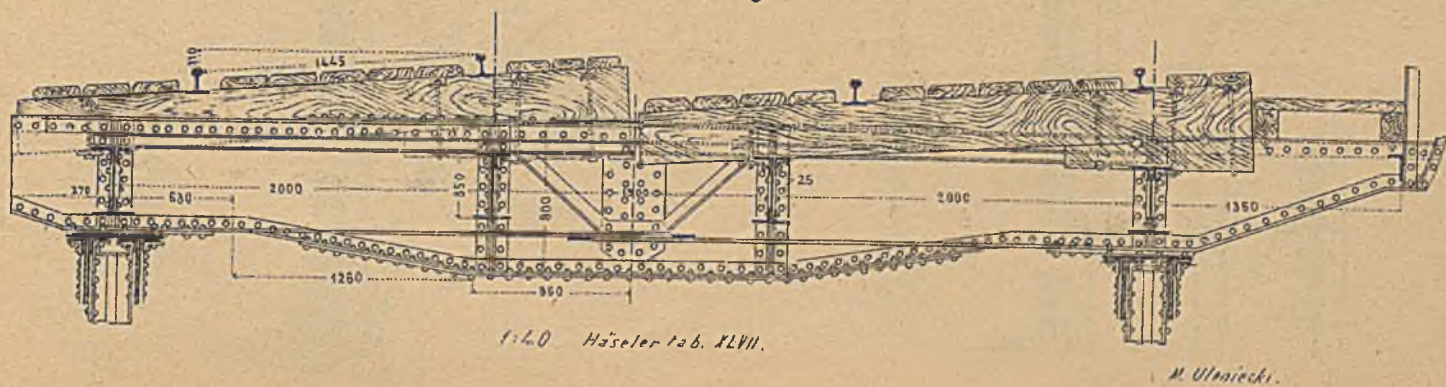

UTWIERDZENIE POPRZECZNIC.

Rys. 1. Most na Saane pod Fryburgiem

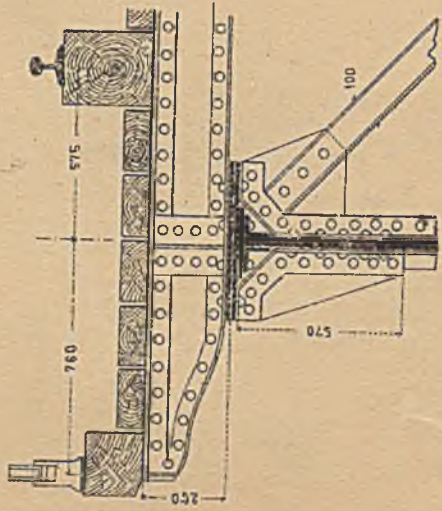

Rys. 2. Most na Birs pod Mönchenstein.

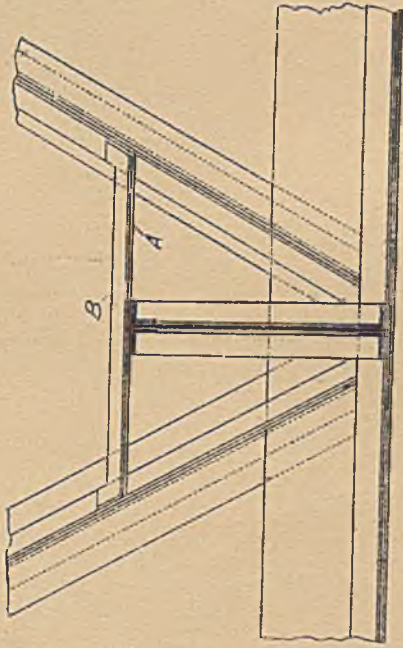

Rys. 3. Przytwierdzenie poprzecznic kratowej przy moście na Dunaju w Kremsie.

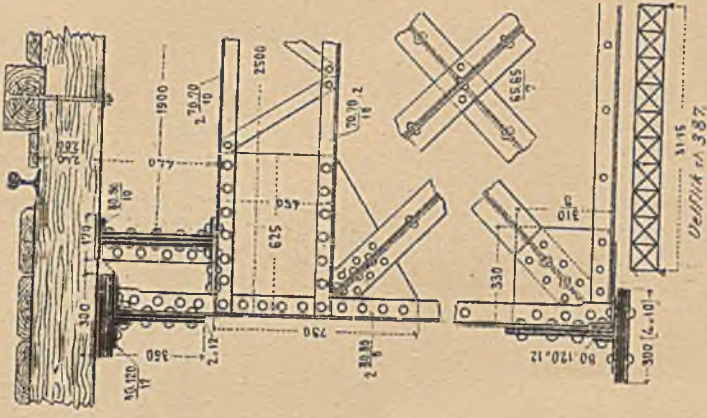

Rys. 4. Most na Lahn pod Ballar 1/30 n.W.

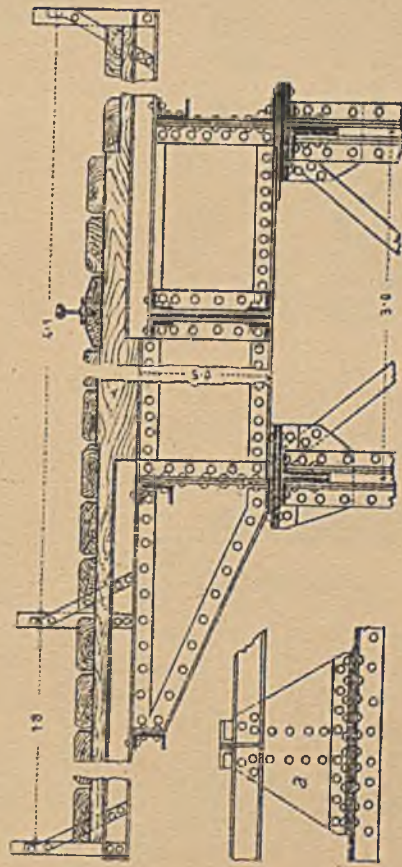

Rys. 5. Most na Lecku pod Kaufering. 1/25 n.W.

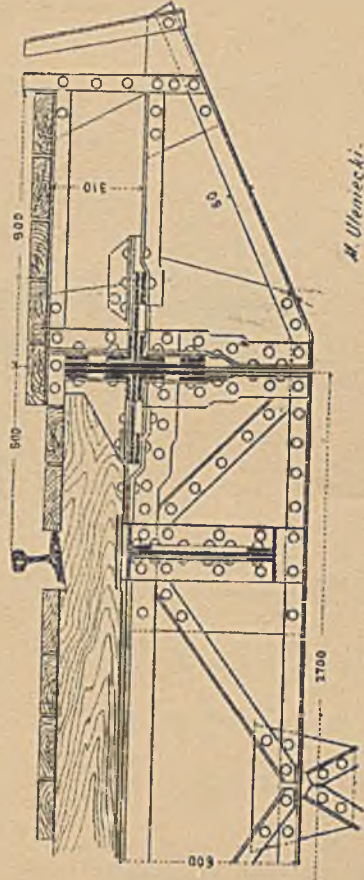

POPRZECZNICE

Rys. 1. a. Most na Strypie w Buczaczu.

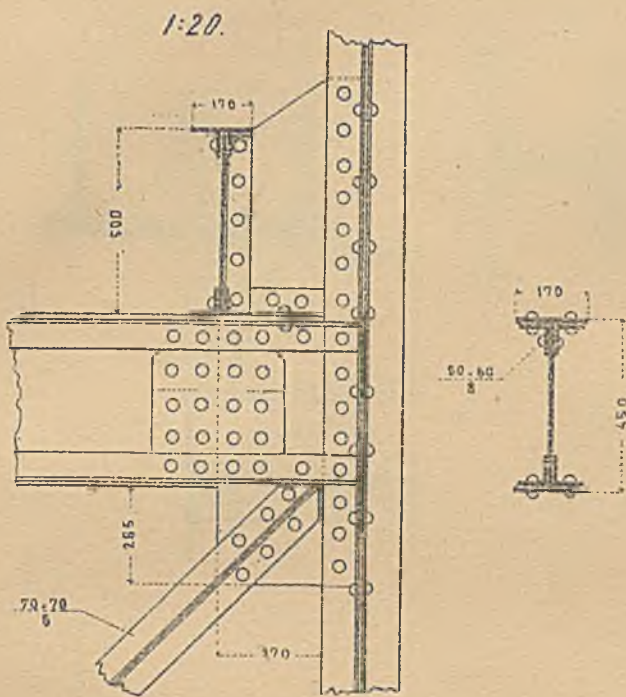

Rys. 2. Most na Dunaju pod Steinbach.

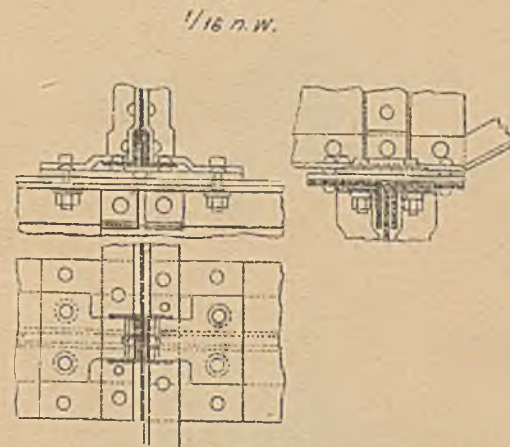

Zeits. d. Ing. u. Arch. Ver. in. Hannover 1890 st. 499.

Rys. 3. Most na Lahnie pod Lahstein.

1/25 n.w.

Rys. 1 b. Rzut poziomy.

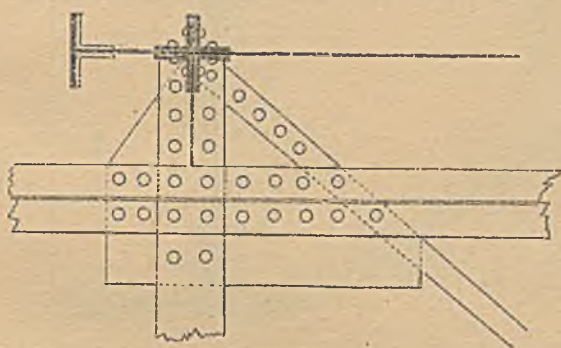

Szerokość mostu od osi do osi 2610
Wysokość belki głównej 3610

Rys. 4

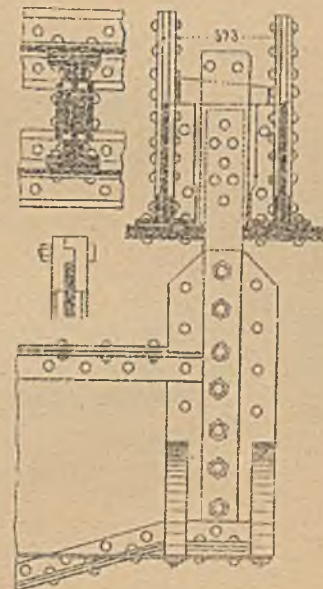
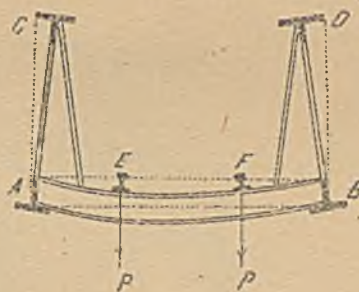

Rys. 7



Rys. 8

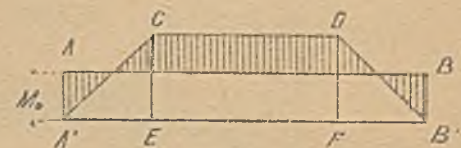

Rys. 5

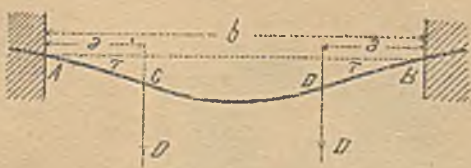

Rys. 6



Rys. 9

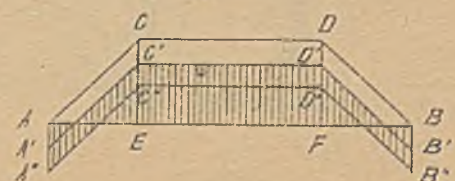

UTWIERDZENIE POPRZECZNIC.

Rys. 1. Nowy most na Trencie pod Newark.

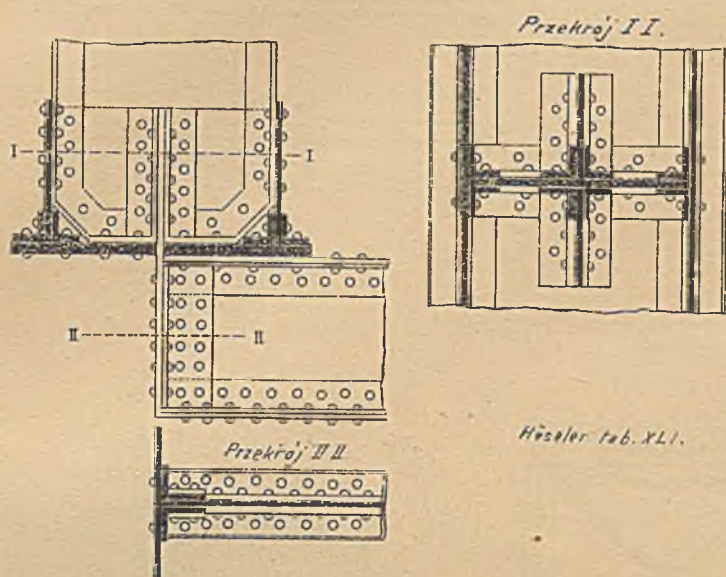

Rys. 2. Most Glästrägerbrücke 1/20 n.w.

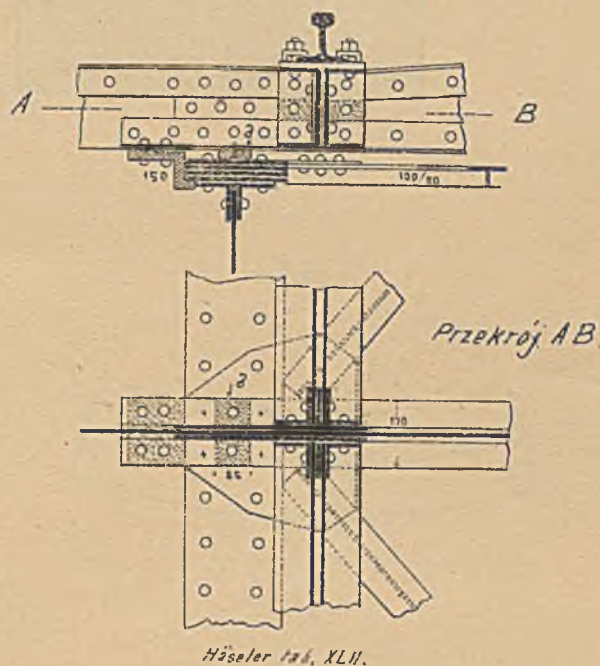

Rys. 3. Most na Renie pod Rhenem.

1/24 n.w.

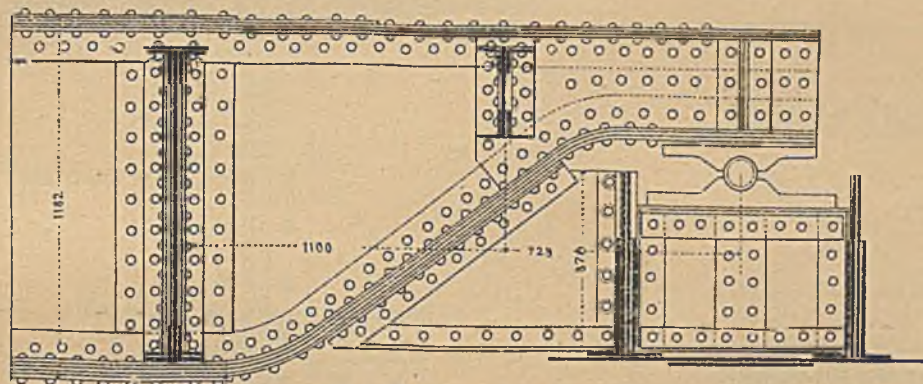

Rys. 4. Most Tolbiac w Paryżu.

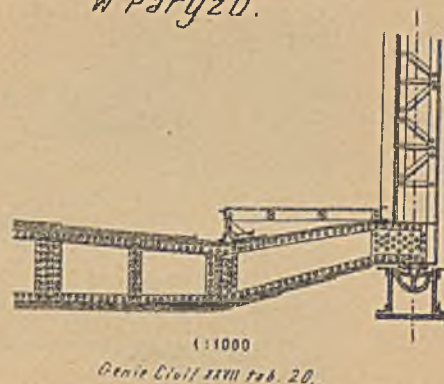

Rys. 5. Most drogowy na Maasie pod Roermond w Holandyi.

1/25 n.w.

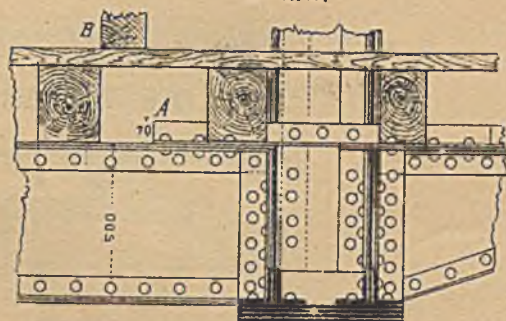

Rys. 6. Most na Boyne pod Droghedą

1/30 n.w.

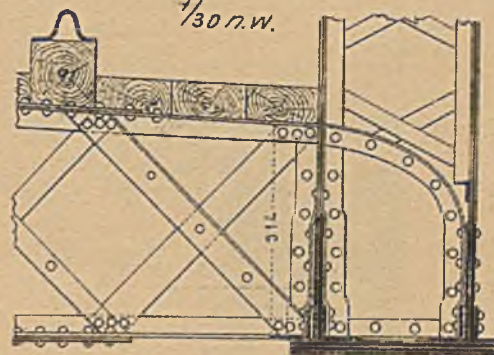

M. Ulaniecki

Rys. 1a, 1b.

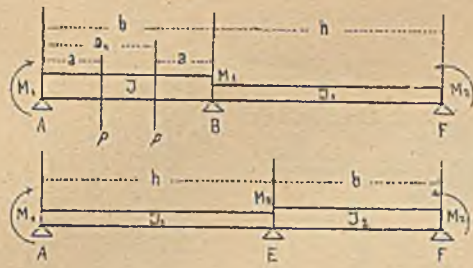

Rys. 2.

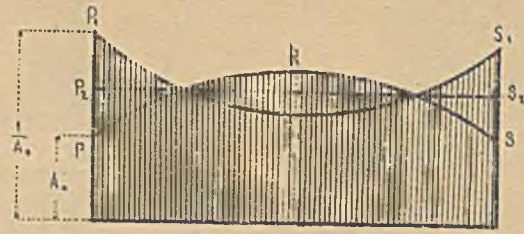

Rys. 3.

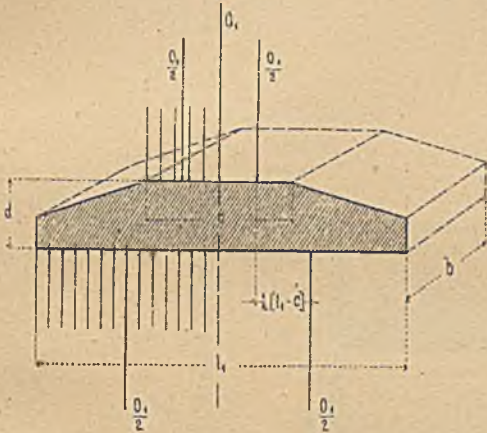

Rys. 4.

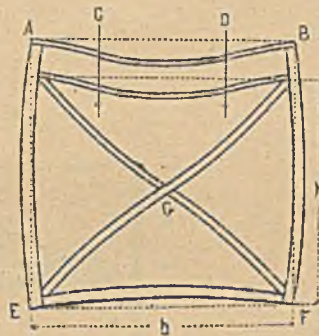

Rys. 5.



Rys. 6. Państwowa kolej hannowerska.

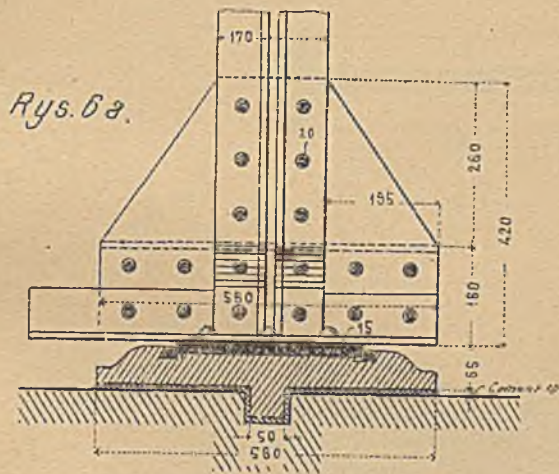

Rys. 6b.

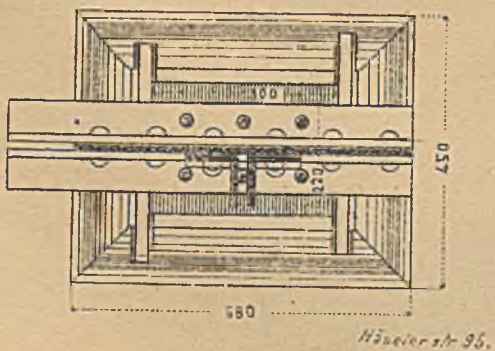

Häselstr. 95.

Rys. 7. Most kolei „Halla-Guben“ pod Delitz.

1/25 n.w.

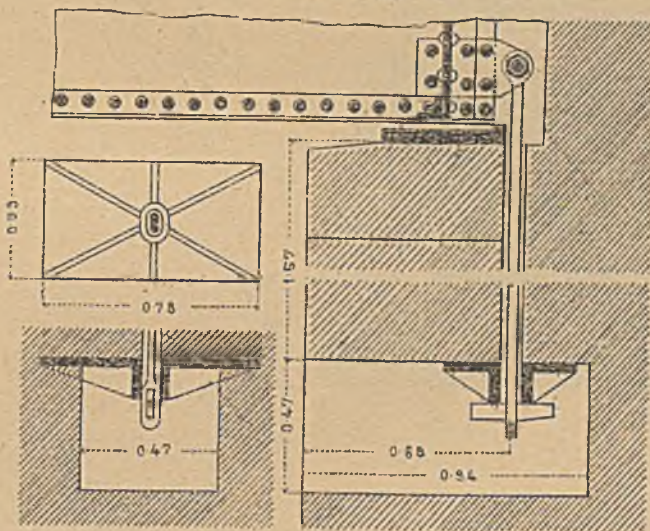

Rys. 8. Normalia austr. kolei południow.

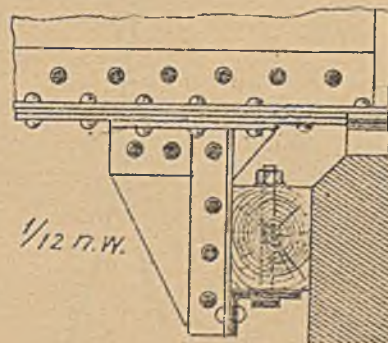

1/12 n.w.

M. Thullie

ŁOŻYSKA WAŁKOWE.

750. 101

Rys. 1.
Most na Jinnie
pod Passawą.



Rys. 2.
Most na Dunaju
pod Stadtlau.

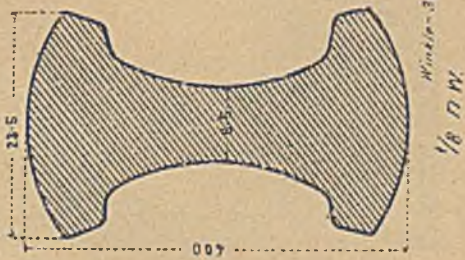

Rys. 3.
Most pod Crosshesselohe.

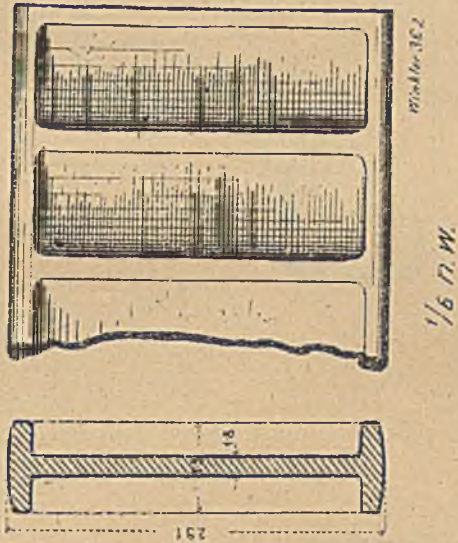

Rys. 4.
Wiadukt na dworcu w Berlinie
kolei, Berlin - Poczdam
Magdeburg.

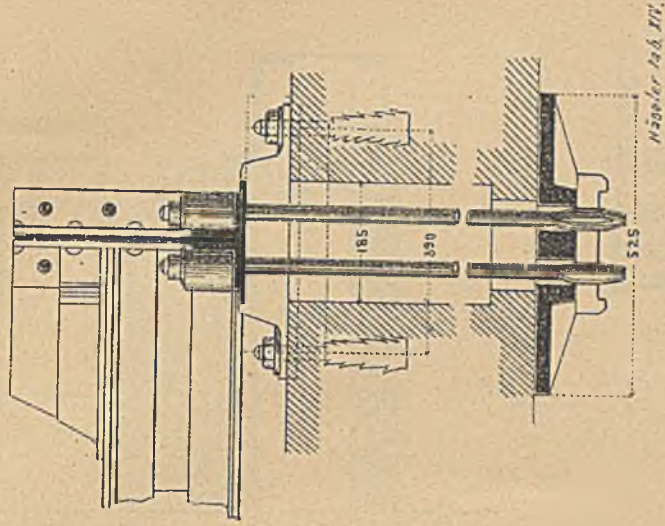

Rys. 5.

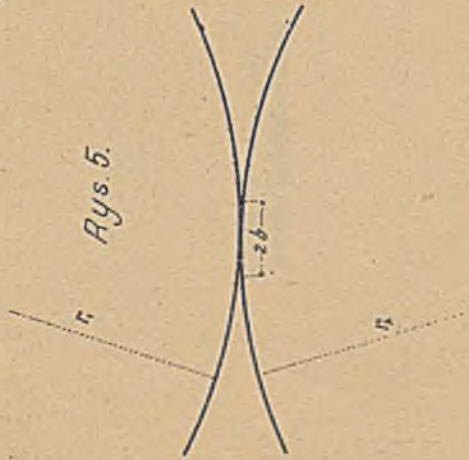

Rys. 6.



Rys. 7.
Most na Sitter
pod St. Gallen.

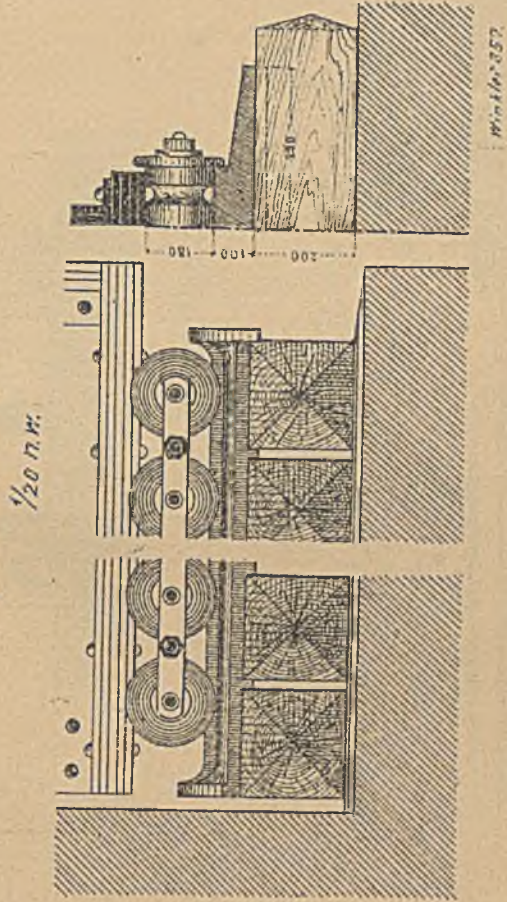

Rys. 8.

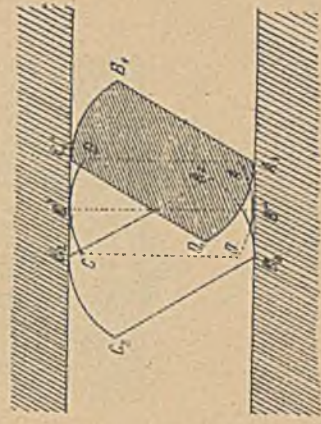

Dr. M. Thullie. Mosty kratowe żelazne.

Winkel

Rys. 1. Most na Dyji pod Znajmem.

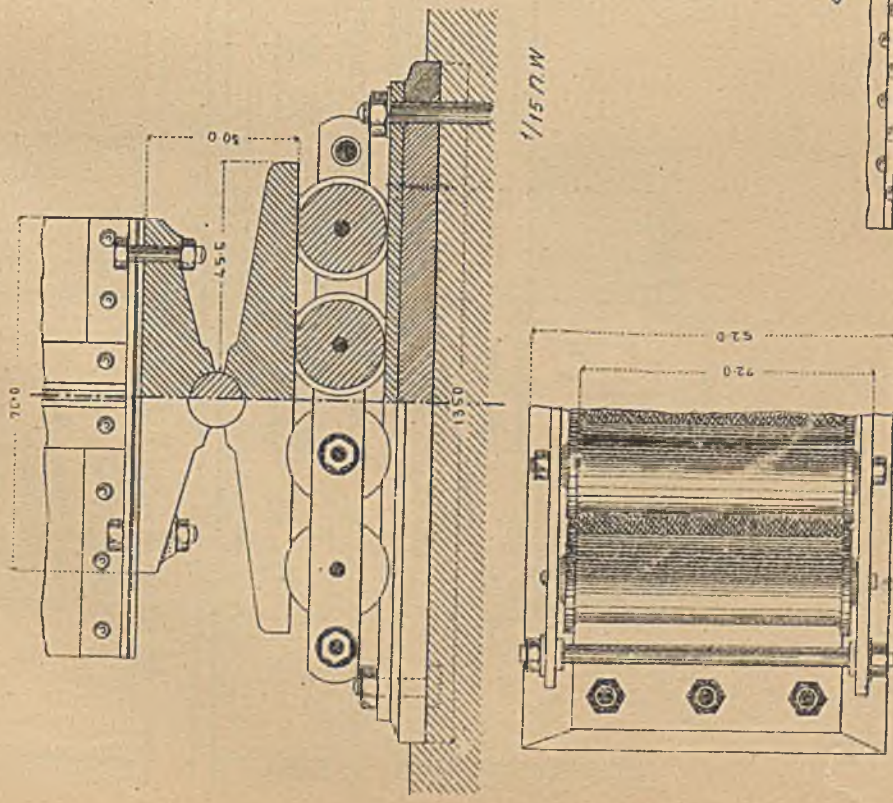

Most kolei warszawsko - kaliskiej nad drogą Łódź - Konstantynów.

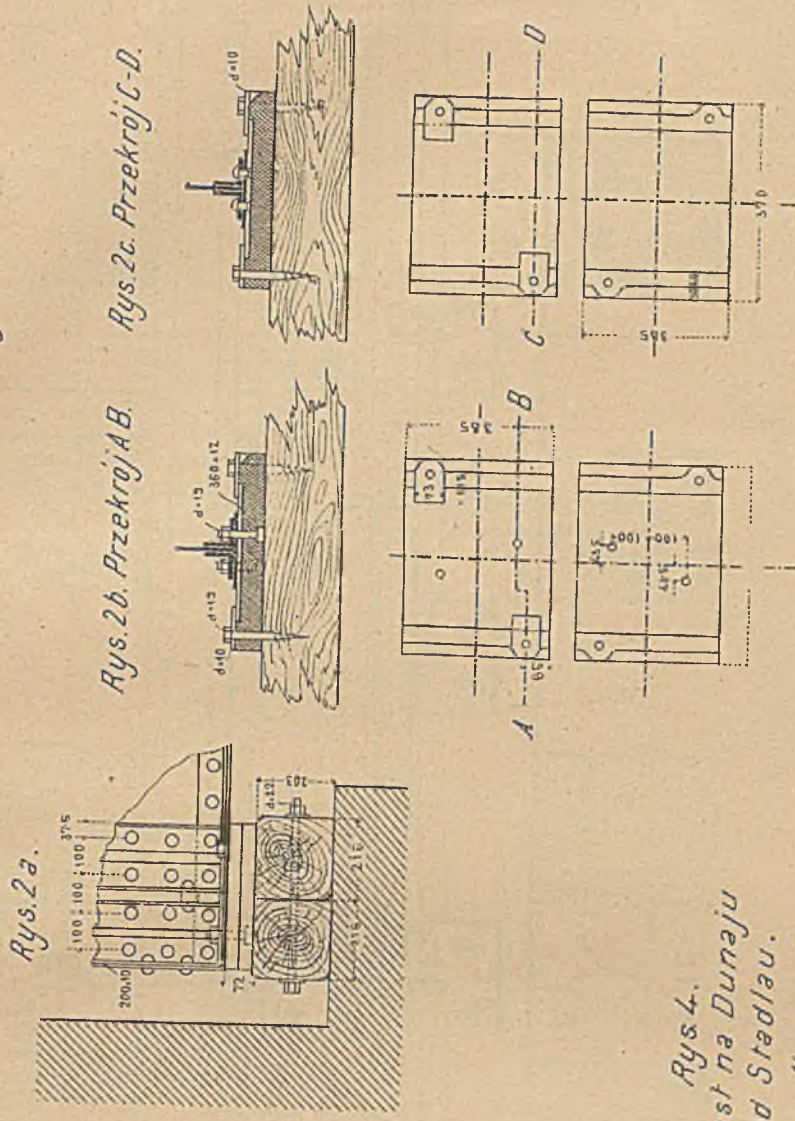

Rys. 2a.

Rys. 2b. Przekrój A B.

Rys. 2c. Przekrój C-D.

Rys. 4. Most na Dunaju pod Stedlau.

1/150 NW.

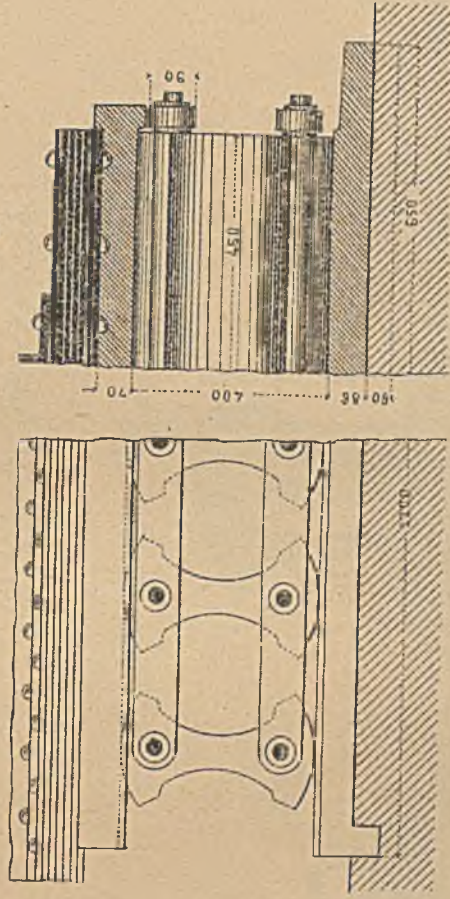

a.

b.

Rys. 2d. Widok.

Rys. 3.

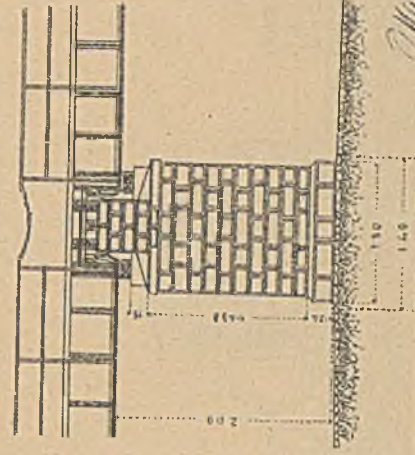
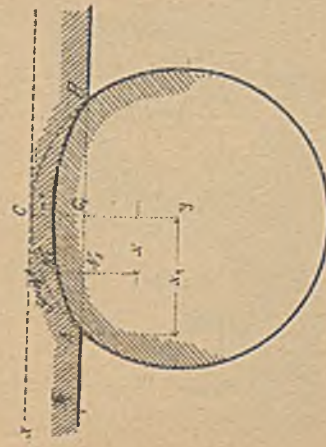

Dr. M. Thullis. Mosty kratowe żelazne.

Most kolei warszawsko - kaliskiej na dworcu w Warszawie.

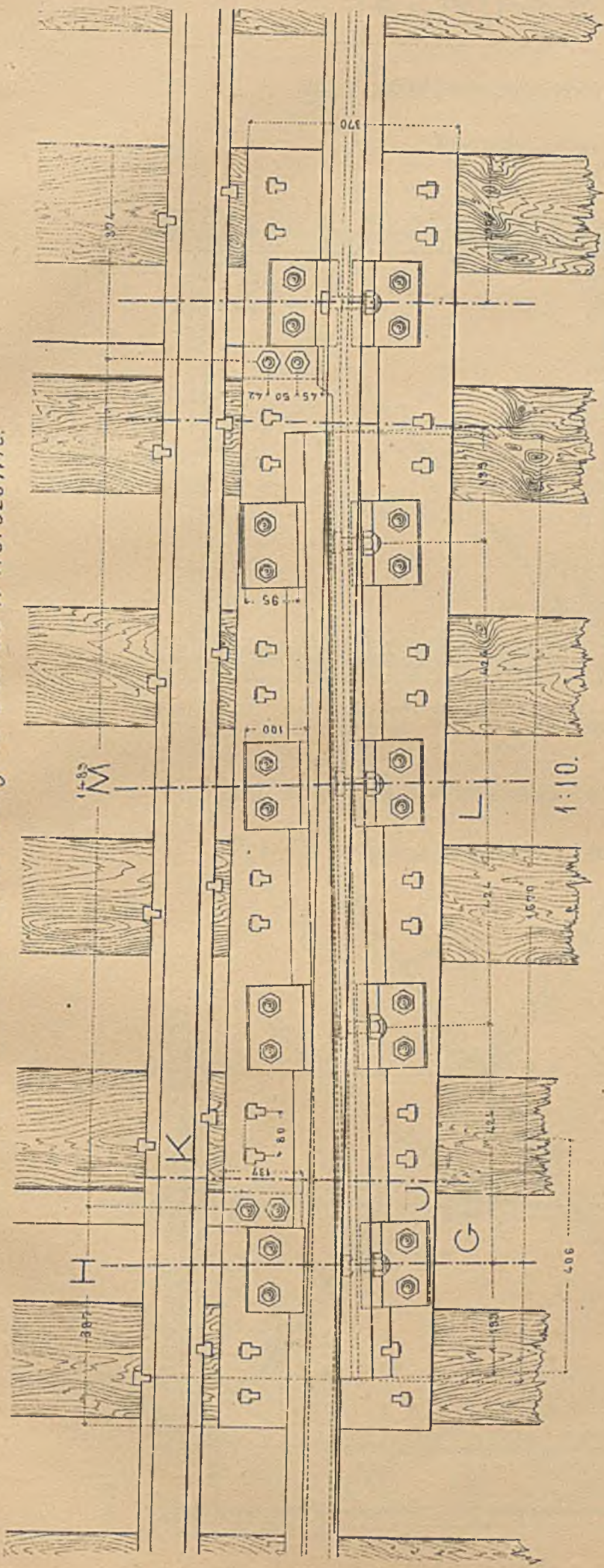

Przekroje poprzeczne.

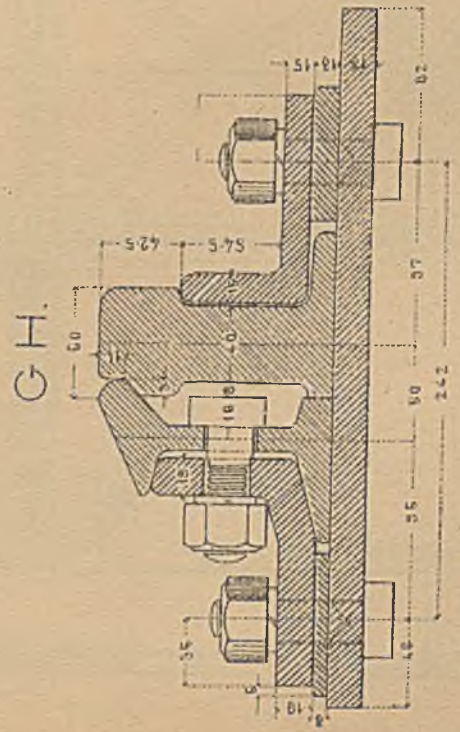

Dr. M. Thullie. Mosty kratowe zelazne.

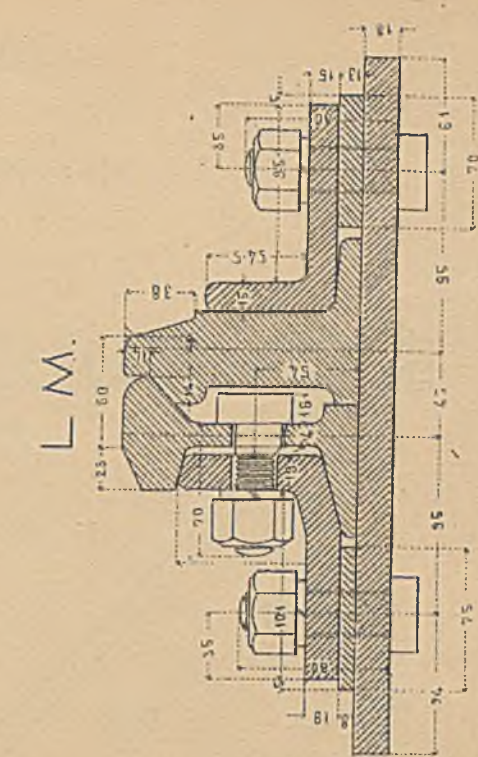
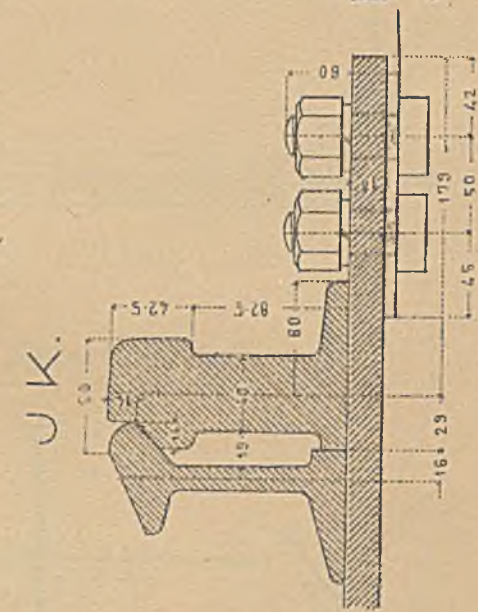

Thullie

TEŻNIKI POZIOME.

Rys. 1. Most kolei przywiślańskiej 3.00 m. św.

Teżniki pojedyncze.

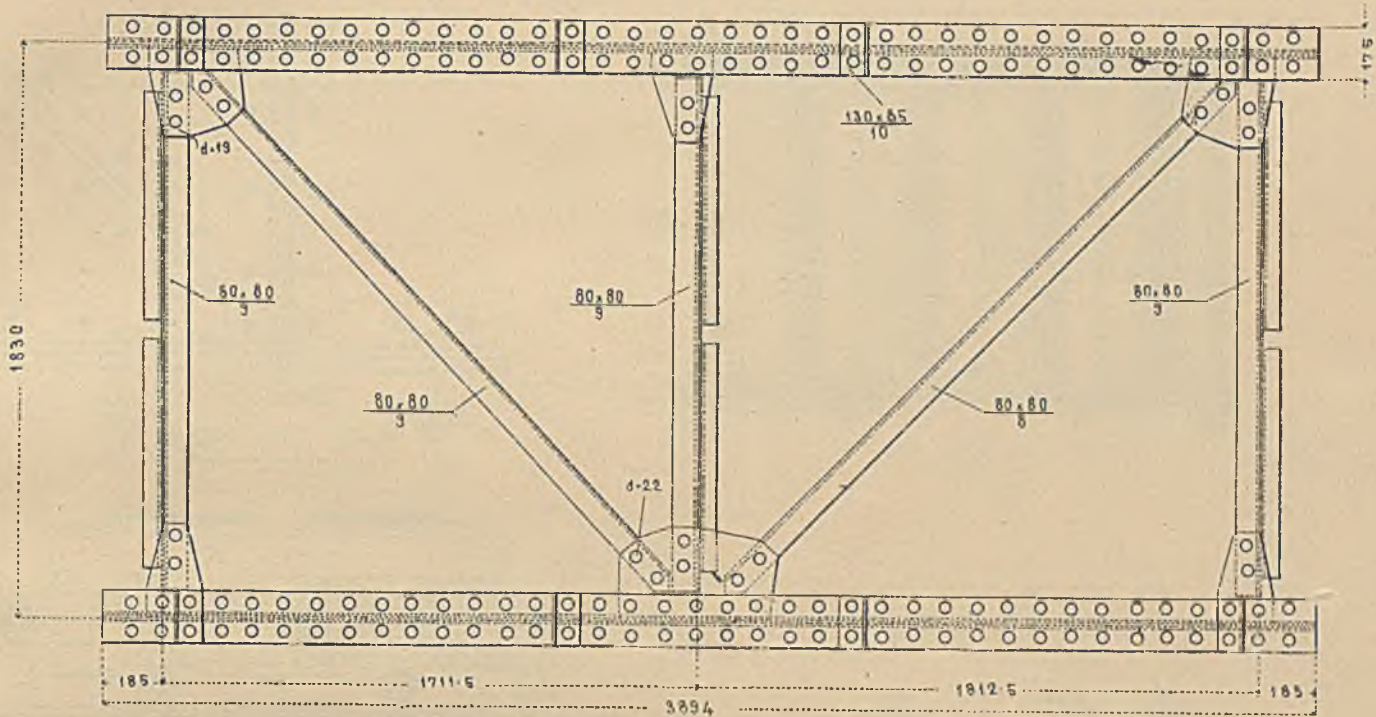

Rys. 2. Most kolei warszawsko-kaliskiej na dworcu w Warszawie.

Teżniki między podłużnicami.

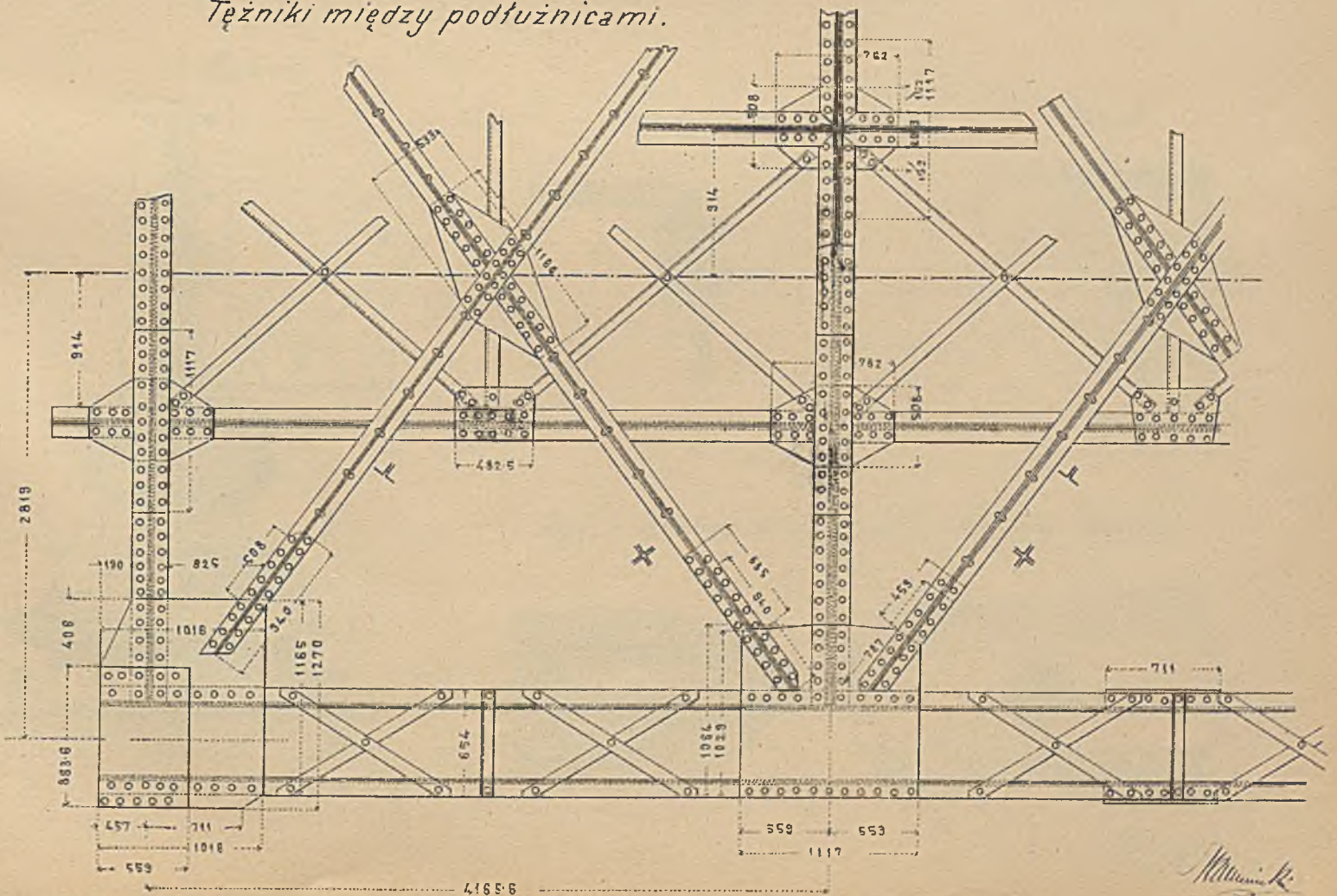

Thullie

ŁOŻYSKA WALKOWE.

Rys. 1. Most nad Amizie koto Duisburgu. 1/25 n.w.

Rys. 1a.

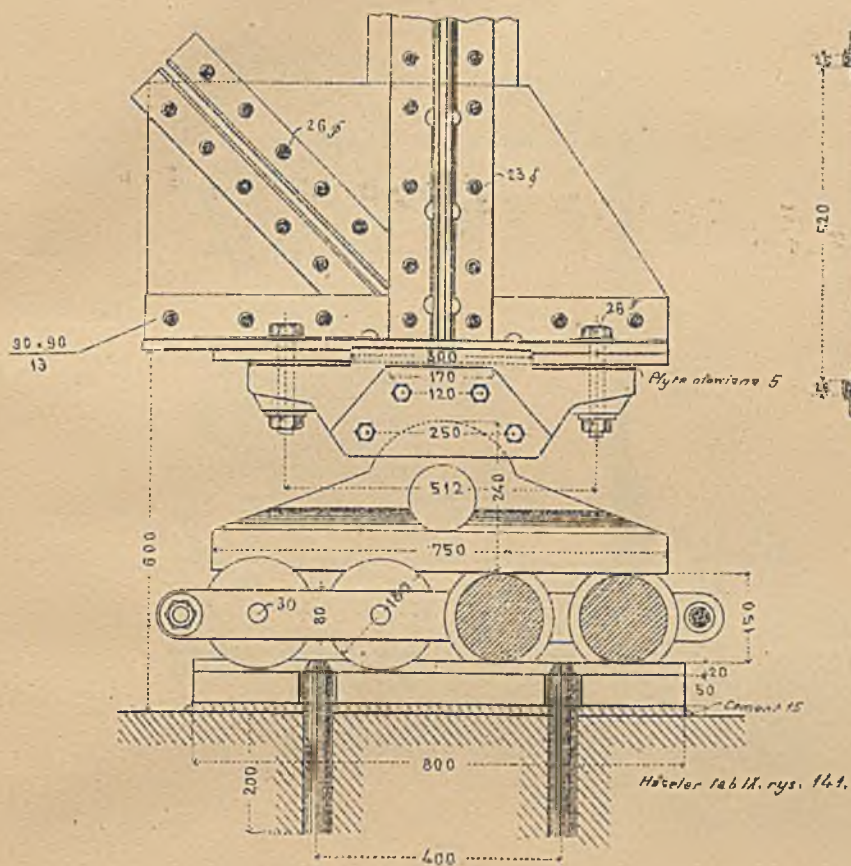

Rys. 1b.

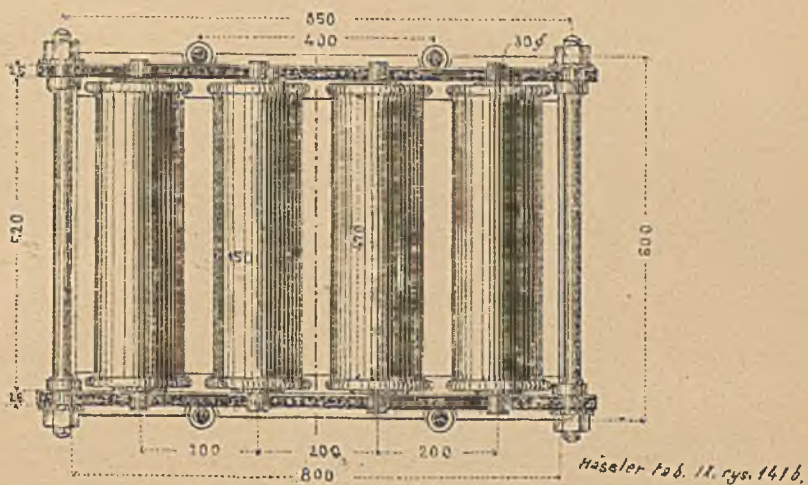

Rys. 2.



Rys. 1c.

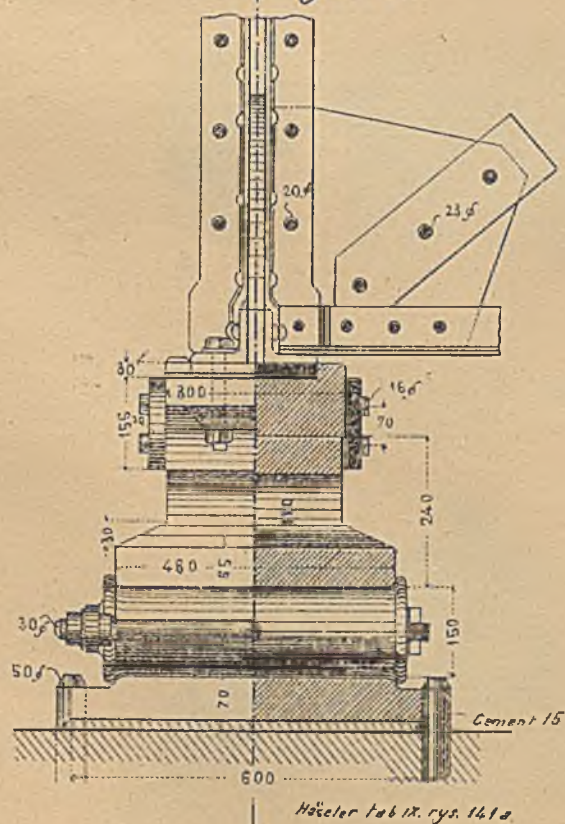

Rys. 3.

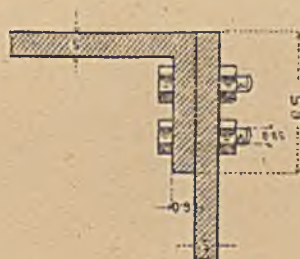

Rama.

Rys. 4.

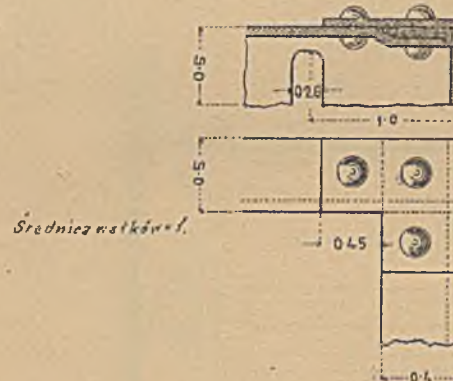

Rys. 5. Most na Dunaju pod Stadlau. 1/5 n.w.

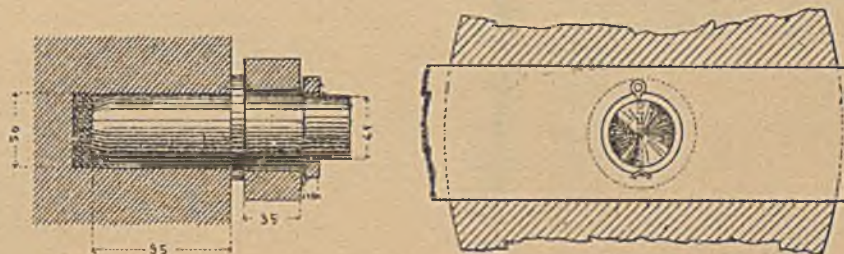

Thullie

ŁOZYSKA WALKOWE.

Rys. 1. Most w Tylży
na Niemnie.
1/5 n.w.

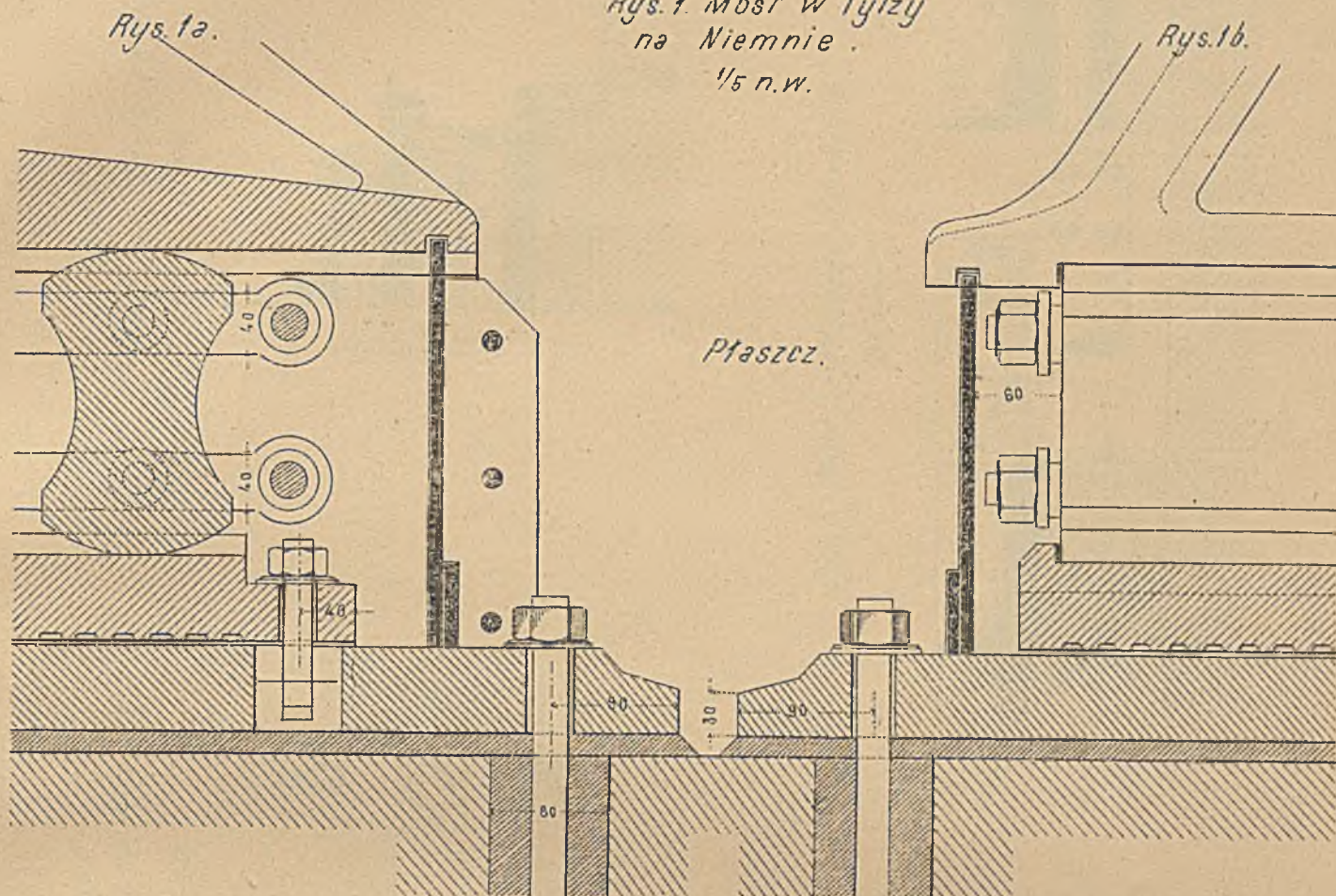

Rys. 2

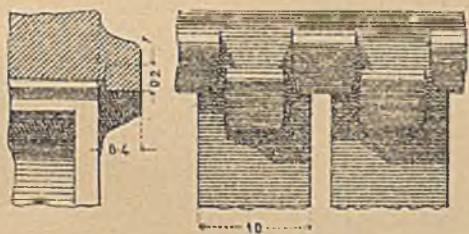

Rys. 3. Kocher-wiadukt pod Tullau.
1/15 n.w.

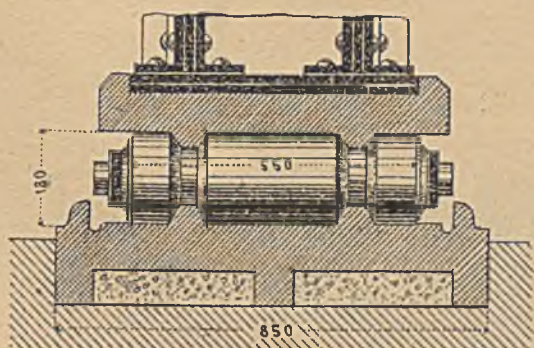

Rys. 1c.

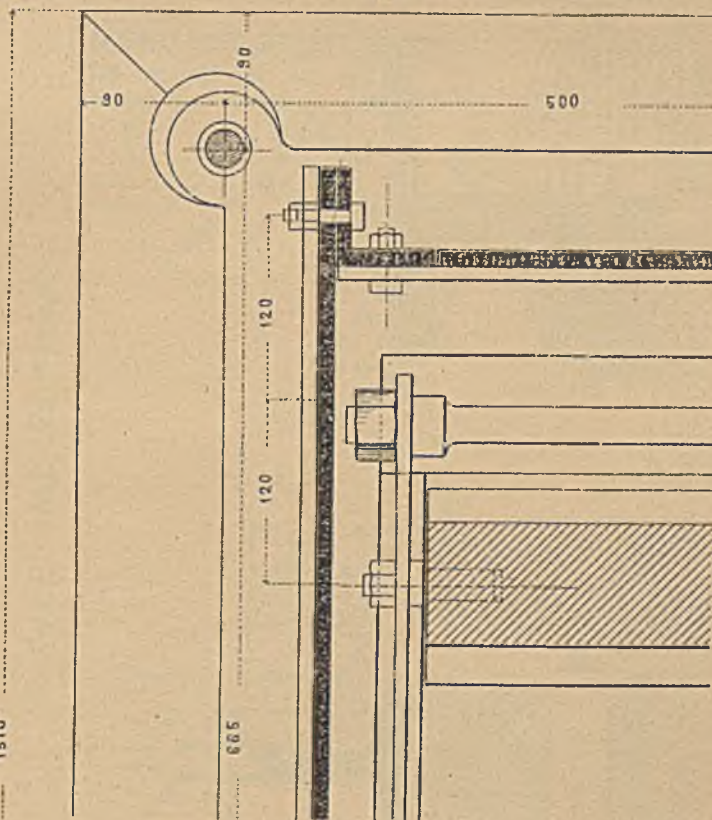

Thullie

ŁOZYSKA WALKOWE.

Rys. 1.



1/10 n.m.

Rys. 2.

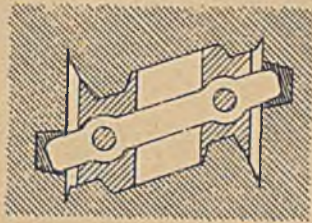

Rys. 3.
Wiadukt na Jgławie.

1/15 n.m.

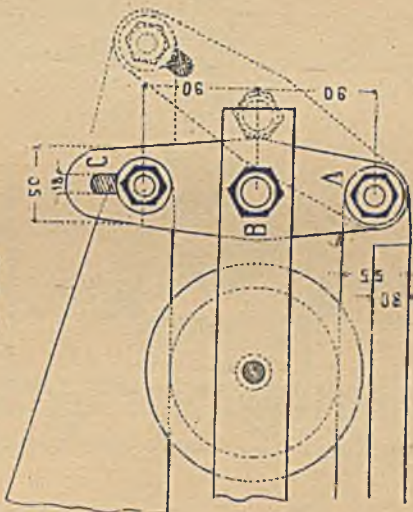

Rys. 4.

Most pod Weilburgiem.

1/10 n.m.

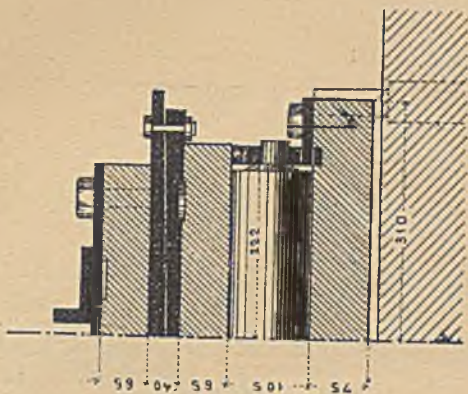

Rys. 5. Most na Elsenz.

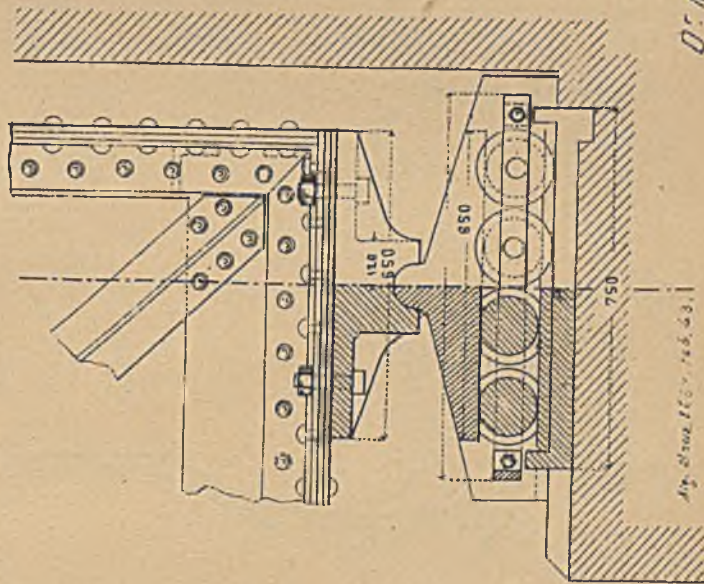
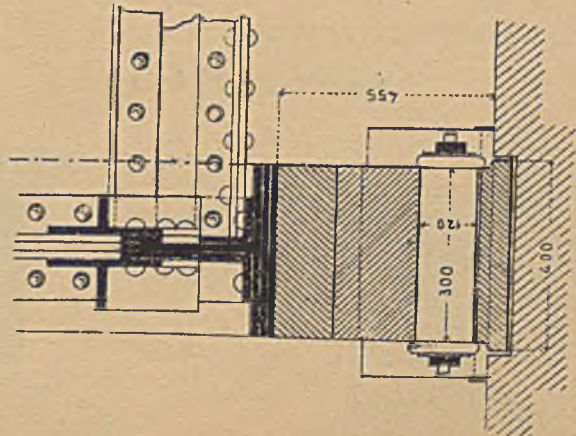

Ag. Stra. 1007. 148. 43.1

Rys. 6. Most na Wezerze w Bremie.

1/15 n.m.

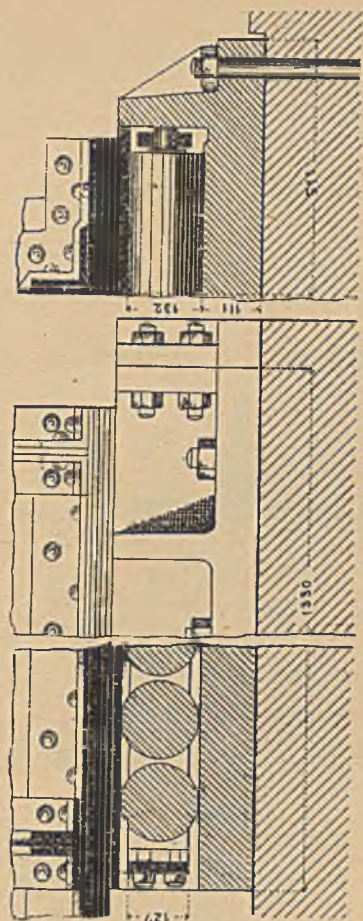

Ullmann

Dr. M. Thullie. Mosty kratowe żelazne.

ŁOŻYSKA.

Rys. 1. Łożysko kuliste przy maście na
Lubianie kolei południowej.

Przekrój podłużny. Widok.

Przekrój. Widok.

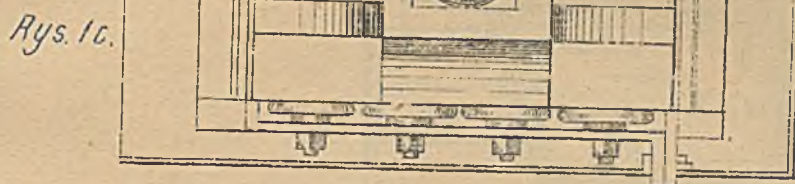
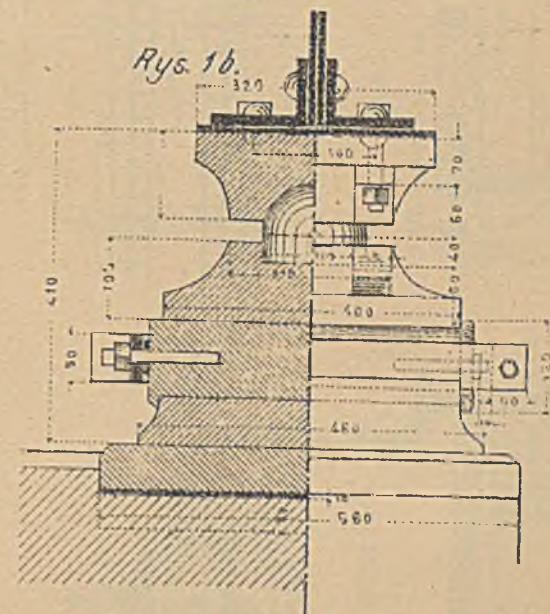
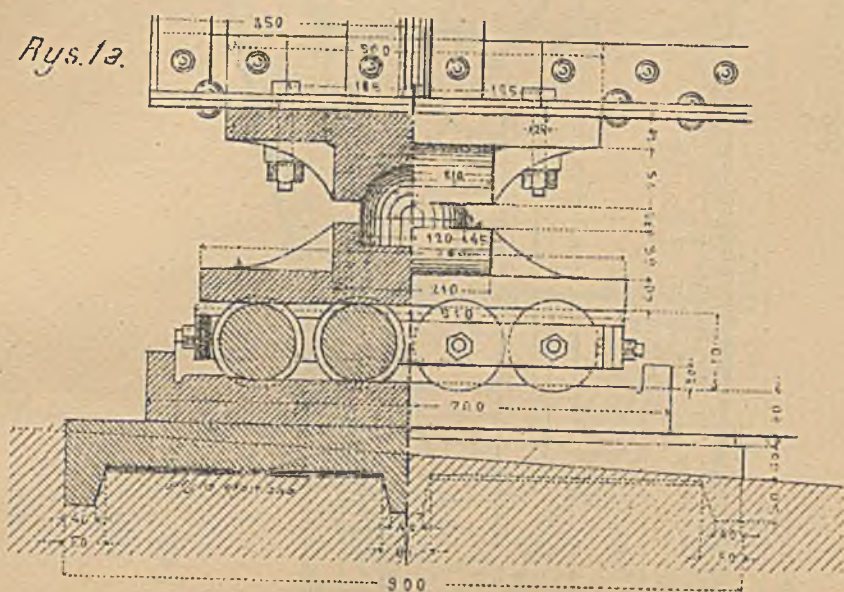

Rys. 2. wedle Tetmajera.

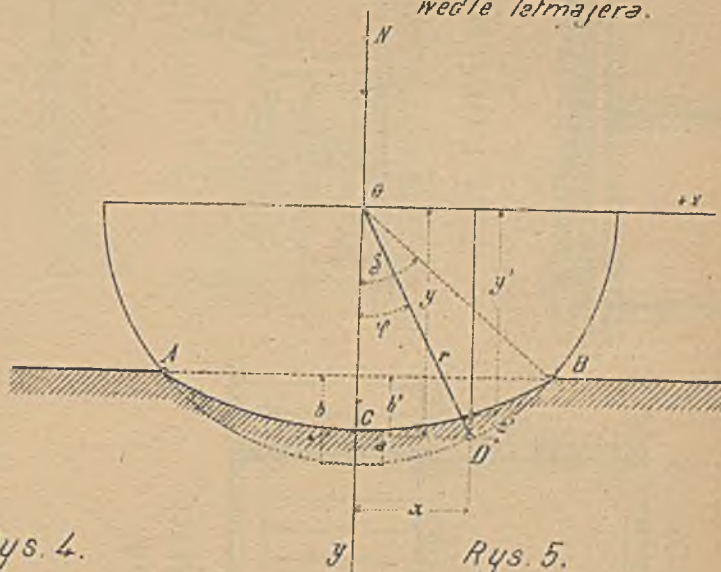

Rys. 3.

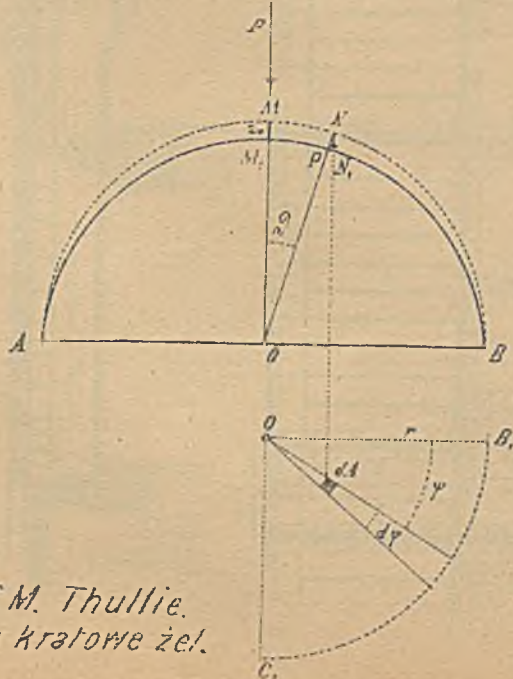

Rys. 4. Rys. 5. Łożyska szcudłowe.

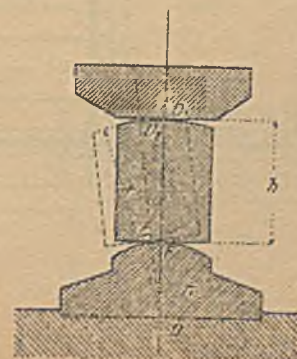
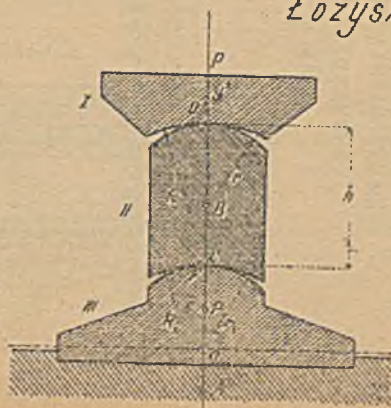

Dr. M. Thullie.
Mosty kratowe żel.

MOST NA RZECE MATT KOŁO BRAUNAU NAD JNNEM 6150 m.św.

Rys. 1. Widok ogólny mostu.

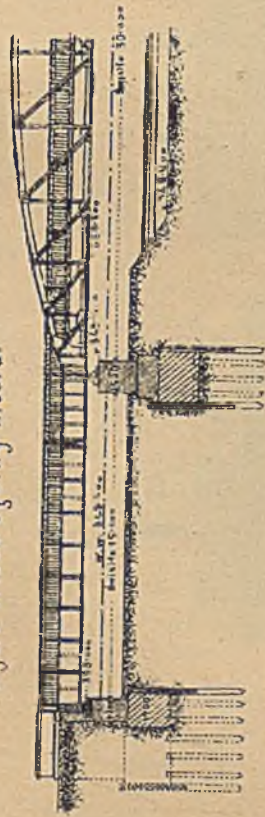

Rys. 2.

Widok belki głównej.

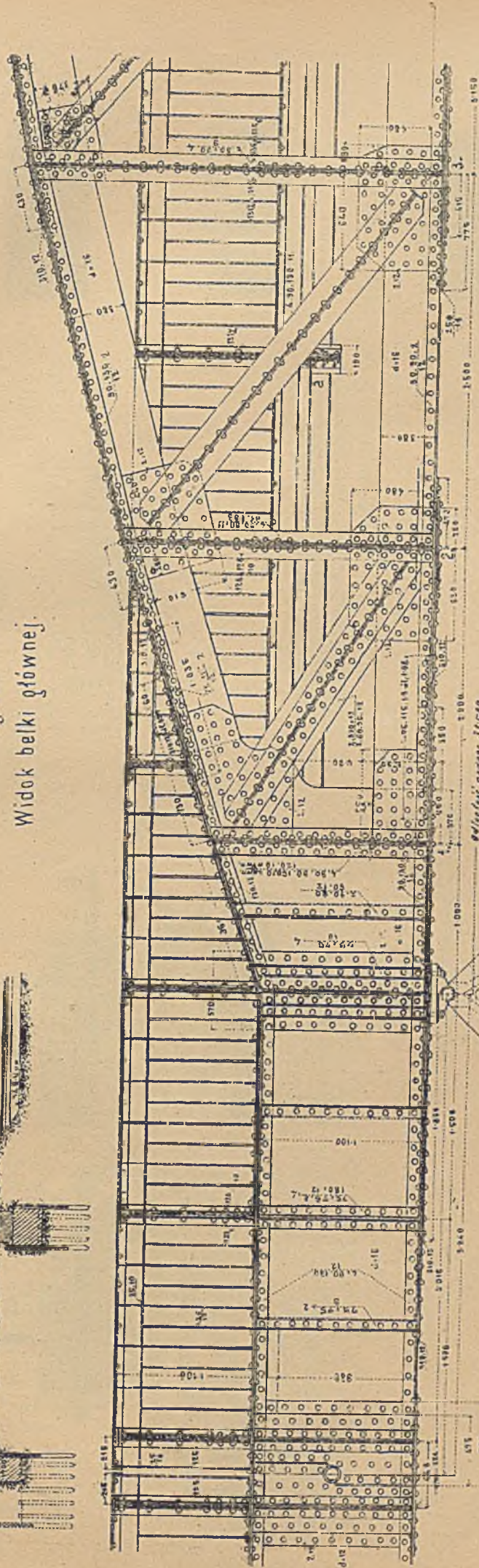

Rys. 3. Zakończenie belki głównej przy łożyskach.

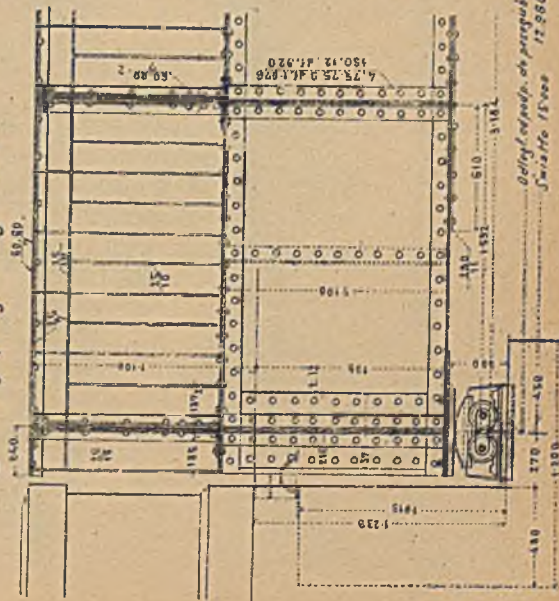

Rys. 4. Łożysko na przyczółkach

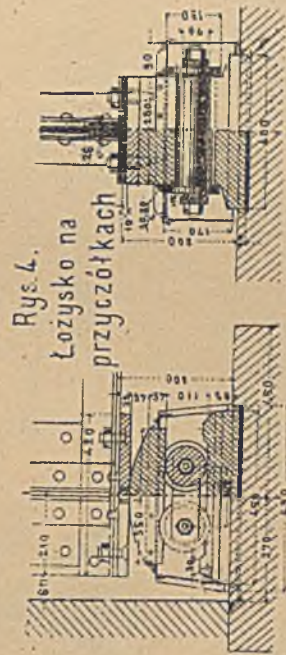

Rys. 5. Szczegół przy przegubie. Widok z góry.

Łopki parowe sprężony

Szwarc 30 mm.

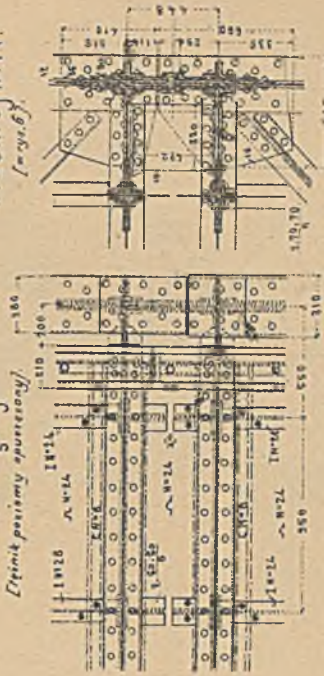

Rys. 6. Przekrój poprzeczny przy przegubie.



Rys. 7. Przekrój podłużny.

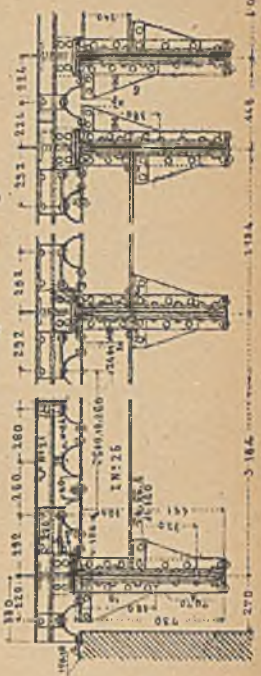

ŁOŻYSKA.

Rys. 1. Płaszcz przy łożysku.
Most na Renie w Kolonii

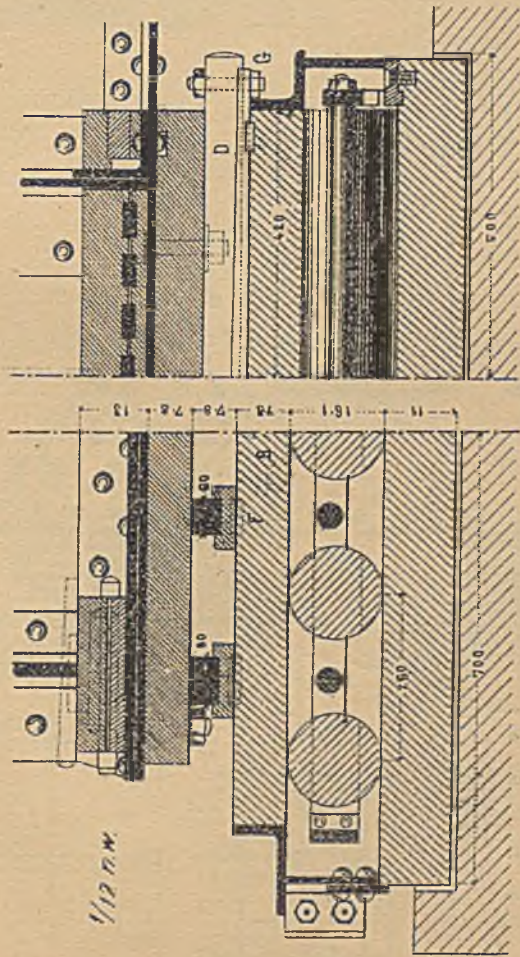

Winkel str. 306 rys. 410.

Rys. 2. Łożysko styczne
przy moście na Dunaju
pod Mariaort.

1/10 n.m.

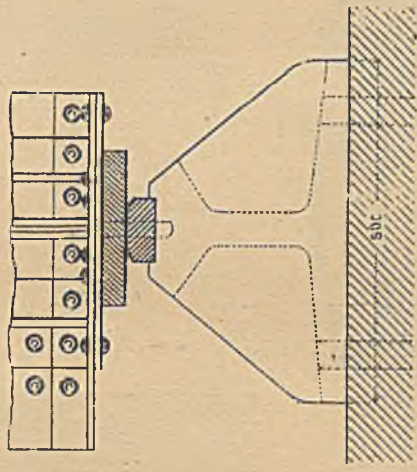

Winkel str. 293 rys. 20

Łożyska czopowe.

Rys. 3.

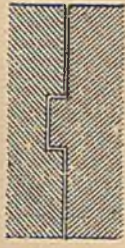

Rys. 4.



Rys. 5.



Rys. 6. Most na Renie pod Mannheim.

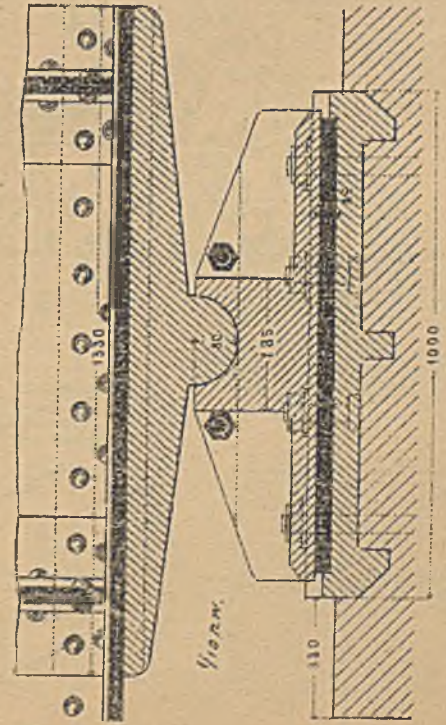

Łożyska kotłowe.

Rys. 7. Most drogowy nad stacją
kolei państwowej we Lwowie.

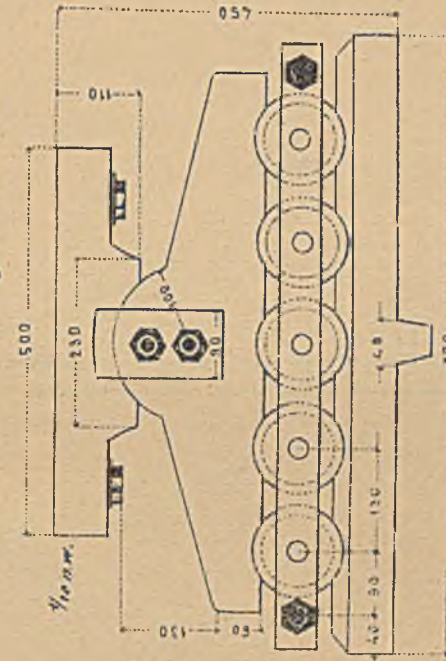

Rys. 8. Most na Dniestrze
w Nizniowie.

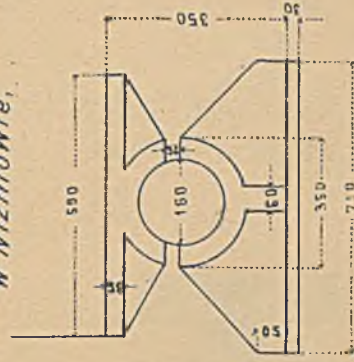

Winkel

D. M. Thullie. Mosty kratowe żelazne.

ŁOZYSKA.

Rys. 1. Most blaszany bawarskich kolei państwowych.
1/10 n.w.

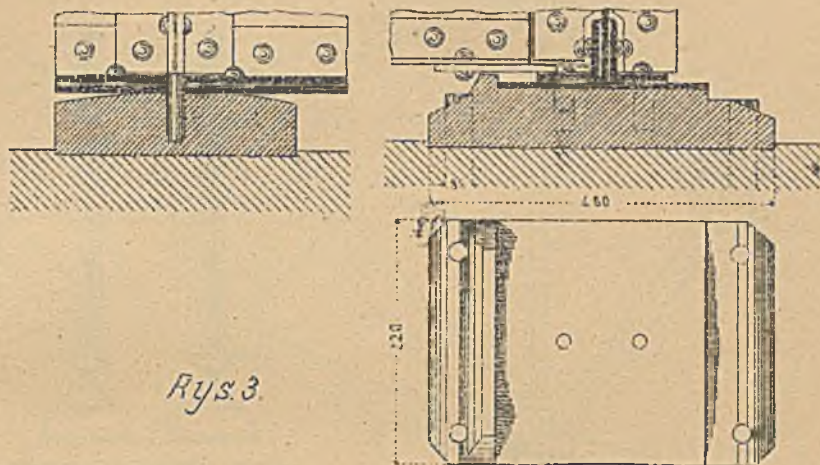

Rys. 3.

Rys. 2. Most na Lecku pod Kaufering.

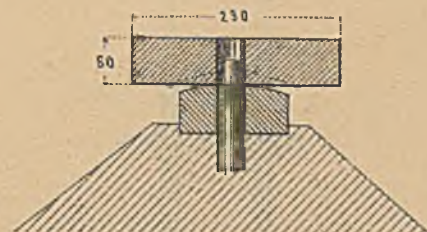

1/10 n.w.

Rys. 4.



Stahler st. 259, fig. 403.

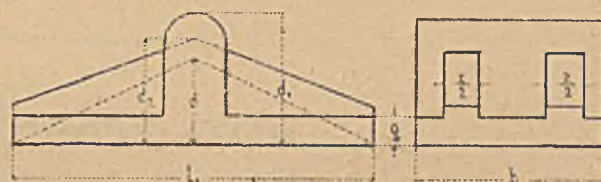

Stahler st. 259, fig. 404.

Rys. 5. Łozysko kuliste przy moście kolei pacyficznej w Kanadzie

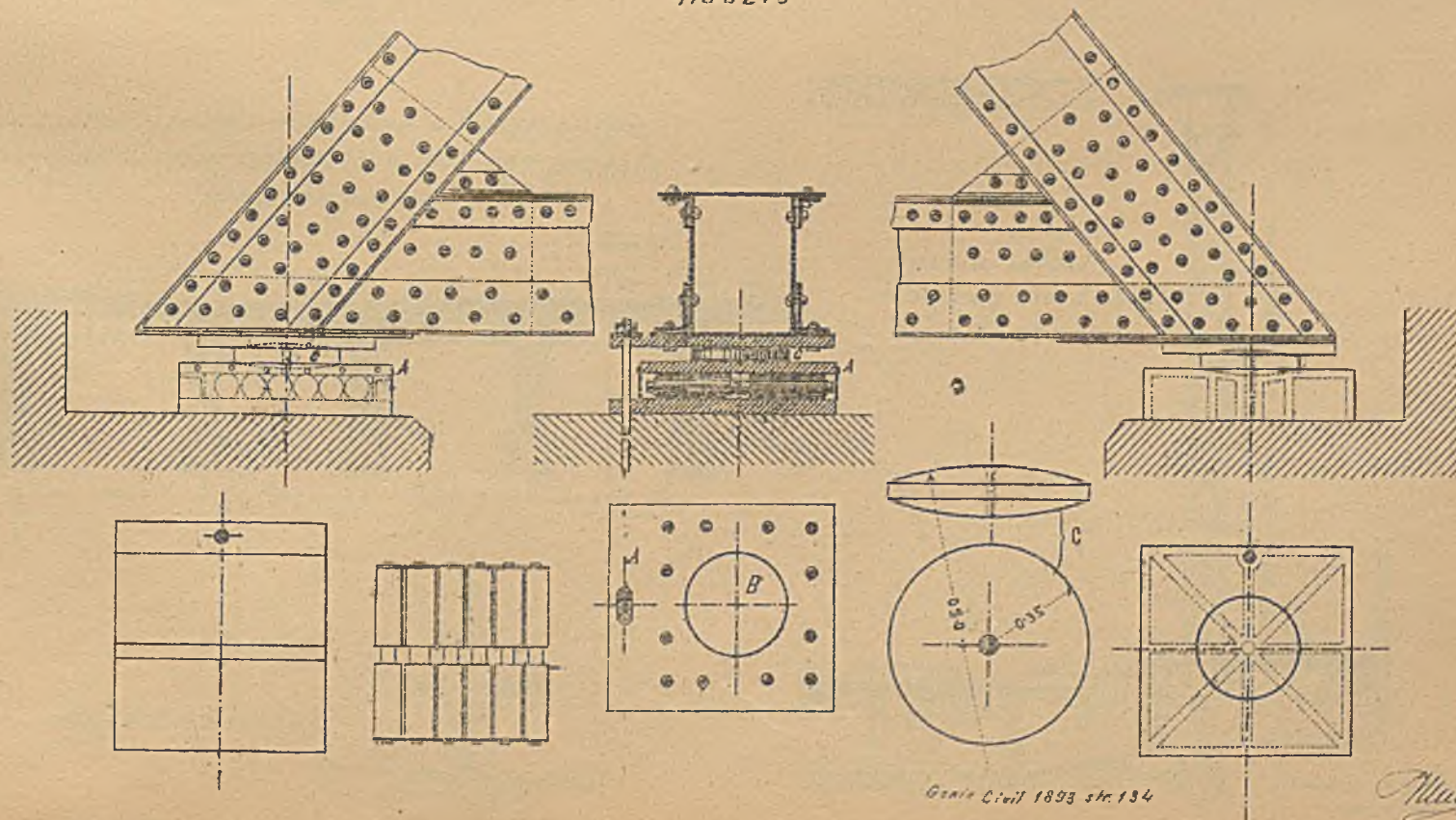

Genie Civil 1893 str. 134

Thullie

ŁOŻYSKA.

Rys. 1. Most na Ulea-Elf pod Uleaburg.

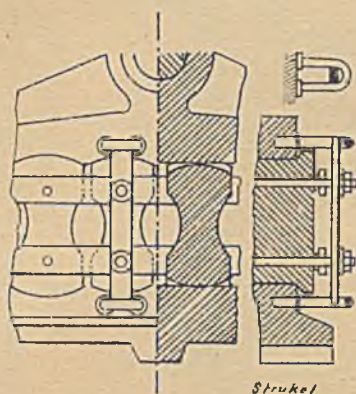

Rys. 2. Łożysko styczne przy moście na Charente.

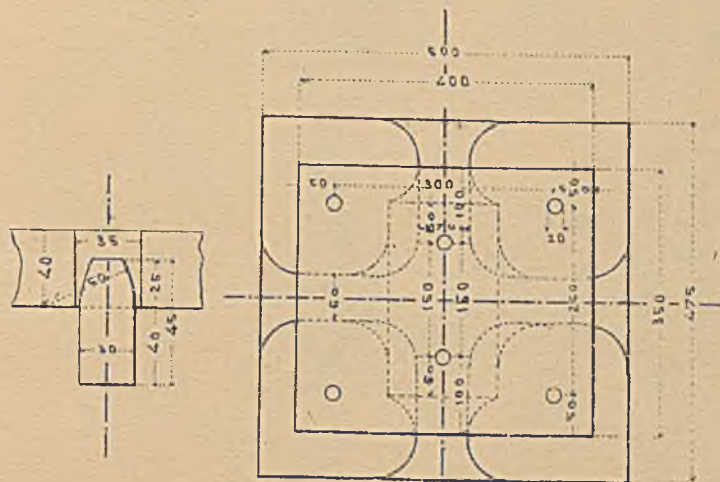

Rys. 3. Most na rzece Dill.

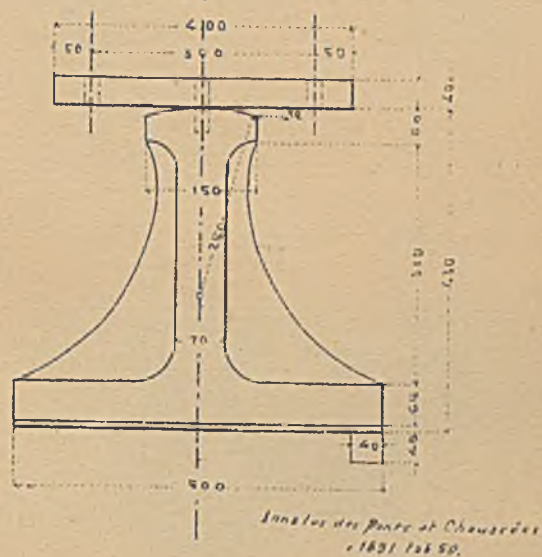
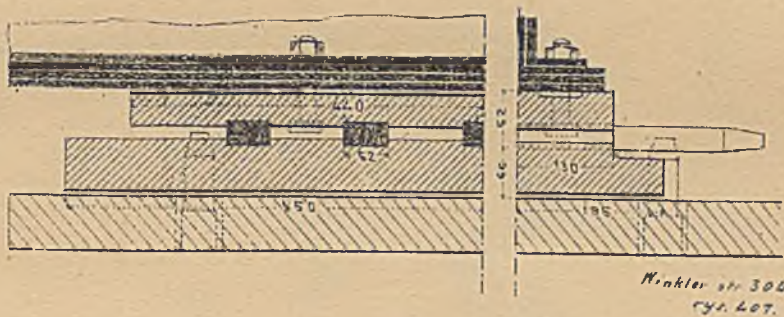

Rys. 4. Miejska kolej w Berlinie. Most nad drogą w parku zamkowym Bellevue.

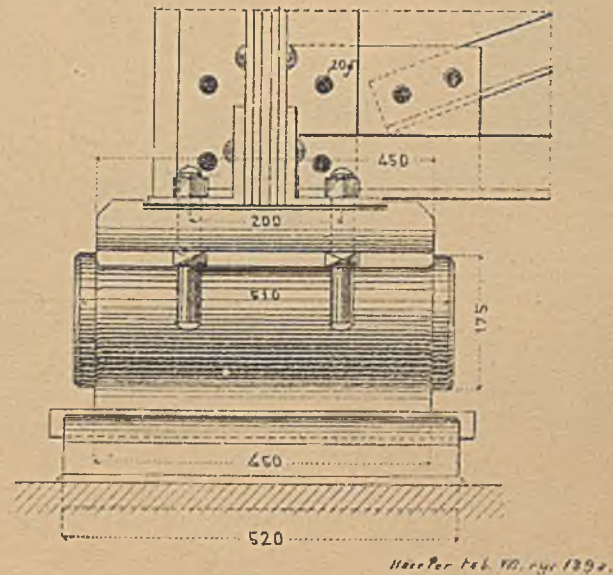
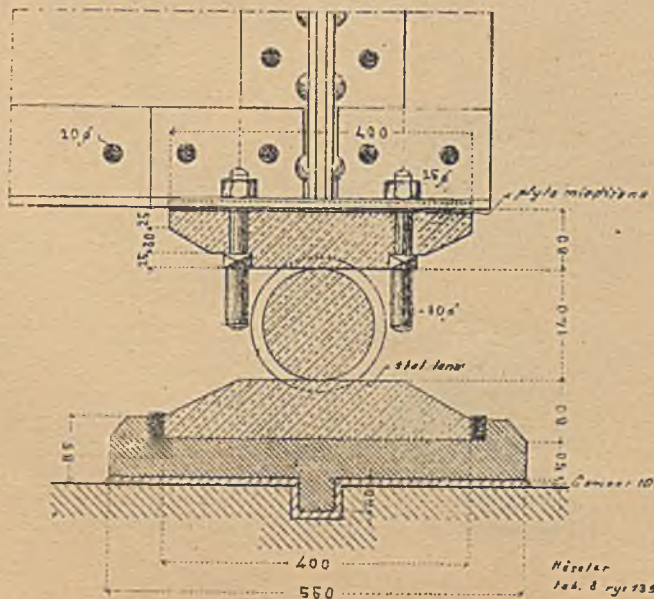

M. Thullie

ŁOŻYSKA.

Rys. 1.

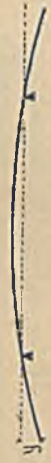

Rys. 2.

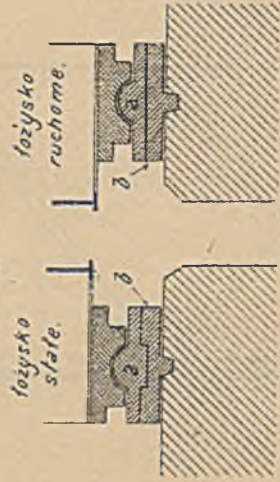

Centr. der. Bauverm. 1891, st. 163.

Rys. 3.

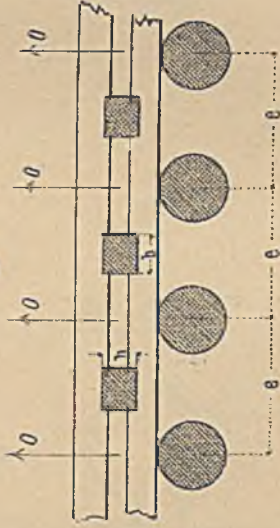

Łożyska klinowe kołyskowe.

Rys. 4. Łożysko klinowe przy moście na starym Renie pod Griethausen.

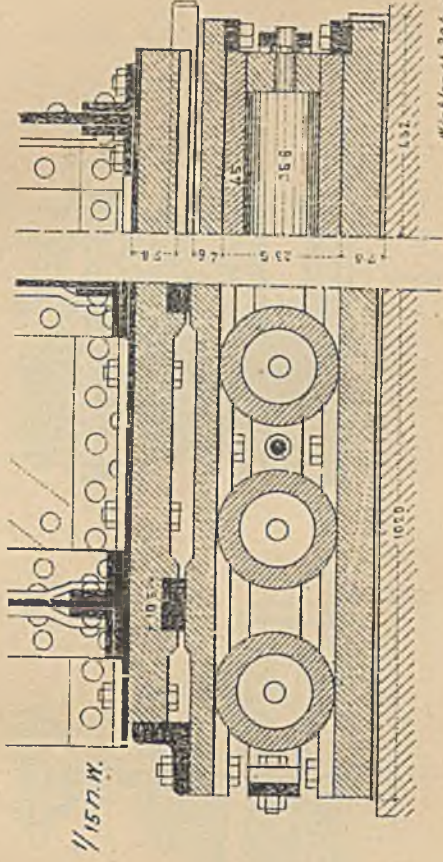

Winkler st. 304, fig. 408

Rys. 5. Most na Łabie pod Hamburgiem.

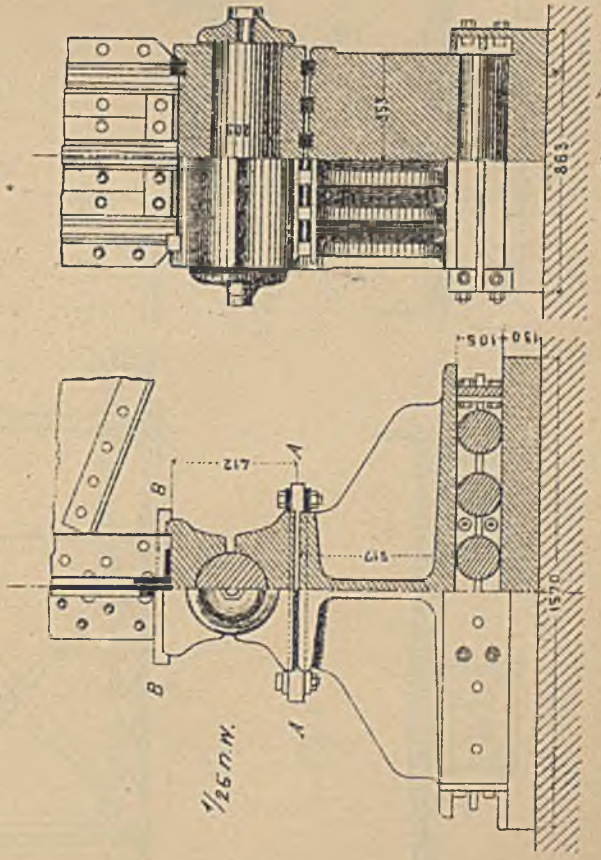

Winkler st. 280, fig. 367.

Rys. 6. Wiadukt nad doliną Thouet obok Tours.

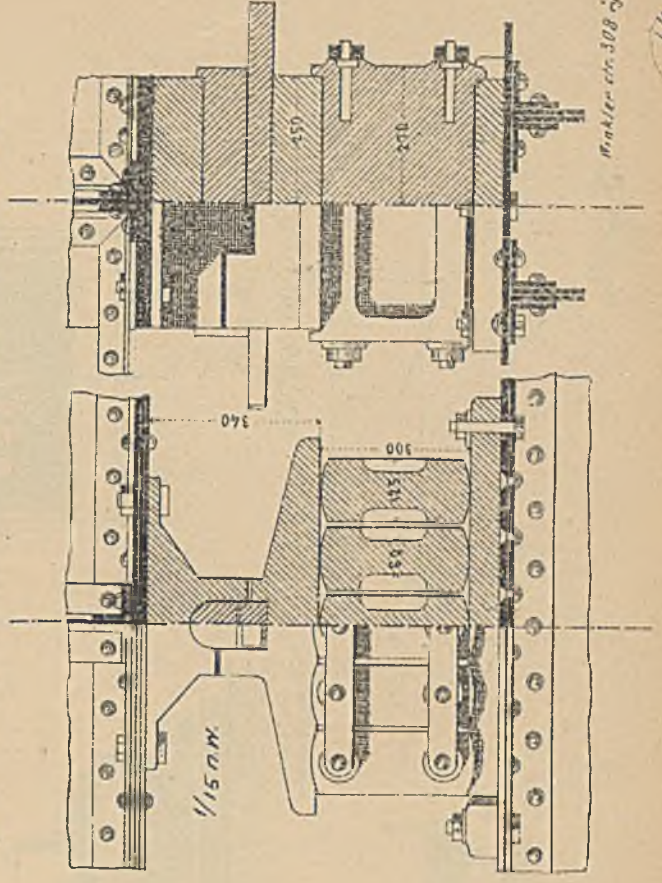

Winkler st. 308, fig. 413.

ŁOZYSKA I TĘŻNIKI POPRZECZNE.

Rys. 1. Most na Moście kolei mikołajowskiej.

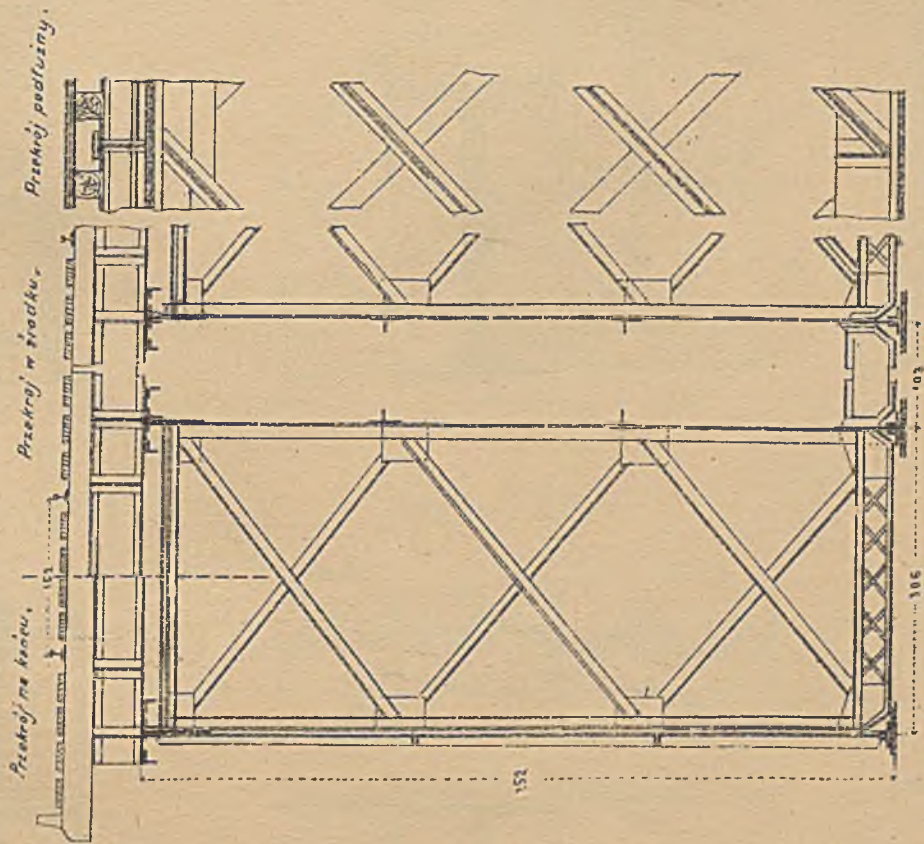

Rys. 2. Łożysko dla przesunięcia w dwu poprzecznych kierunkach przy nowym moście na Wiśle pod Tczewem.

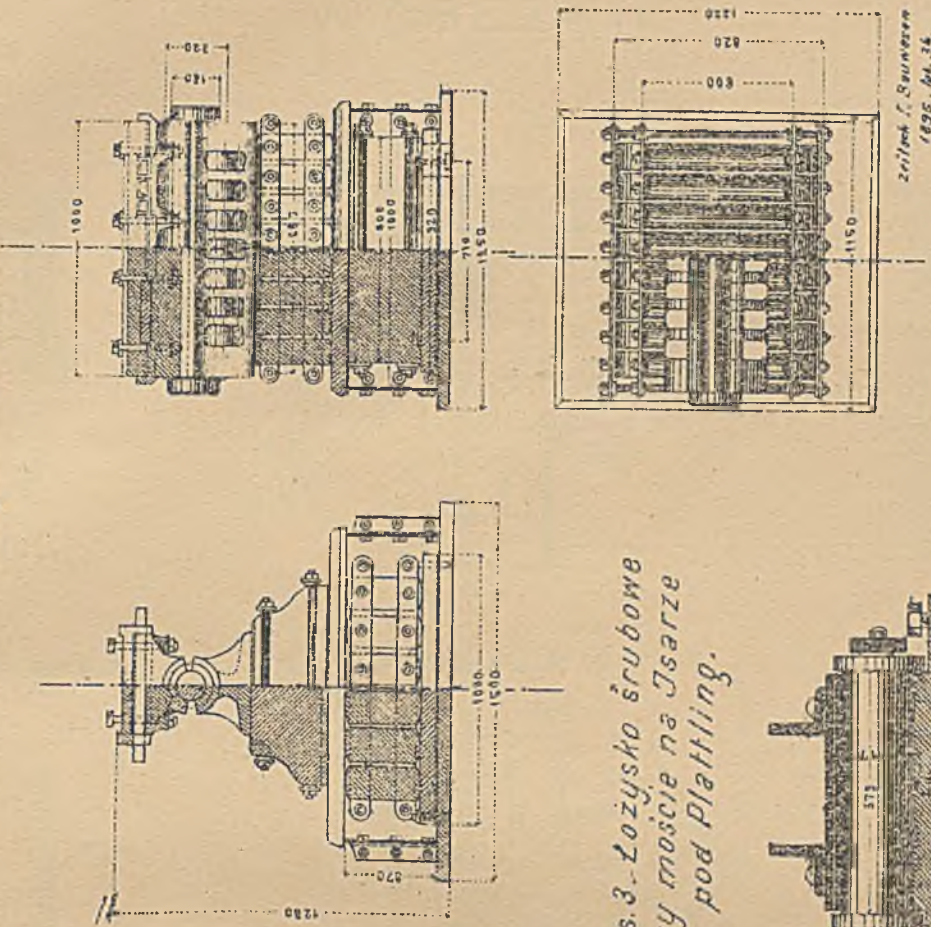

Rys. 3. Łożysko śrubowe przy moście na Isarze pod Plattling.

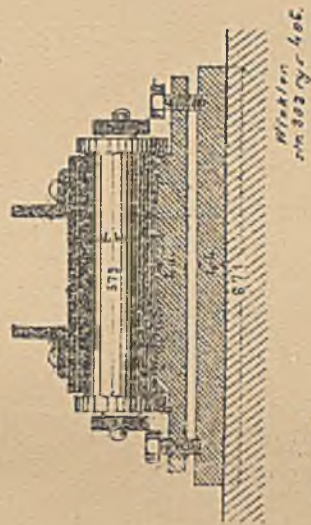

Rys. 5.



Rys. 4.

Rys. 6. Układ łożysk.



Mikelen

PRZEGUB PRZY MOŚCIE NAD DWORCEM W DREŹNIE.

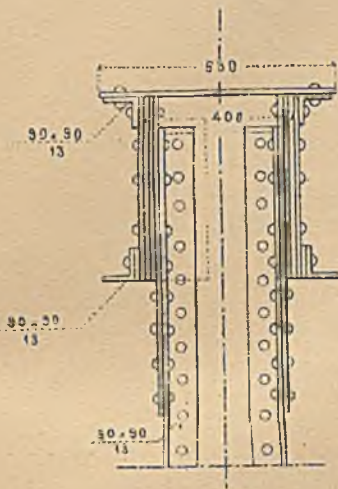

Widok boczny G.H.

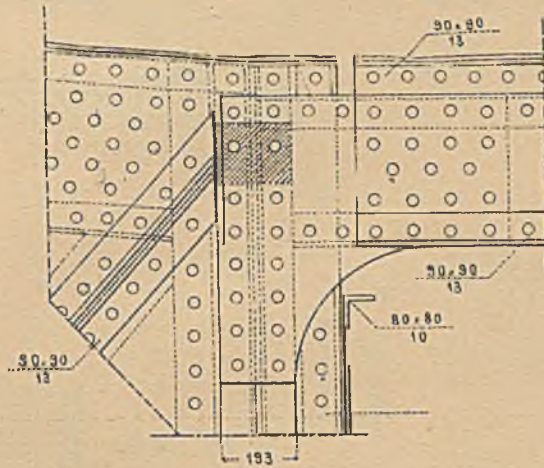

Przekrój KLMN.

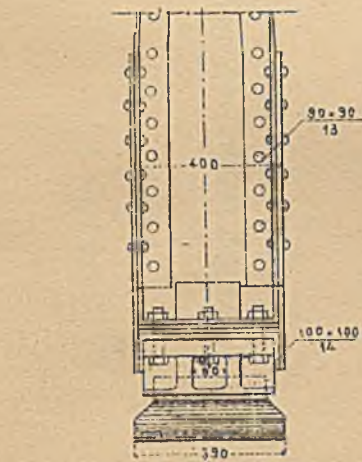
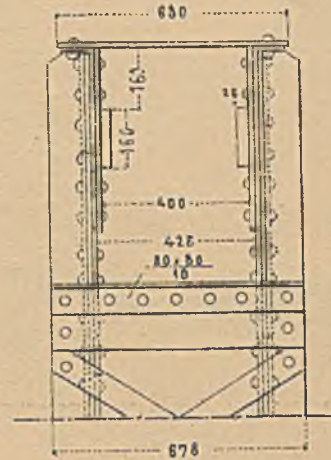

Przekrój EF.

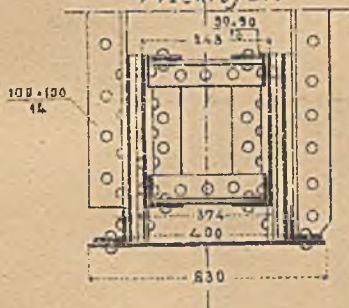

Przekrój XX.

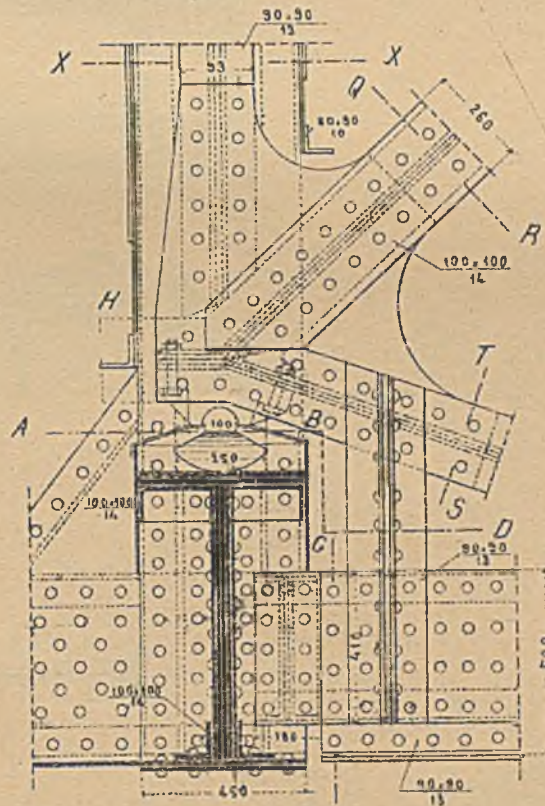

Przekrój ABCD.

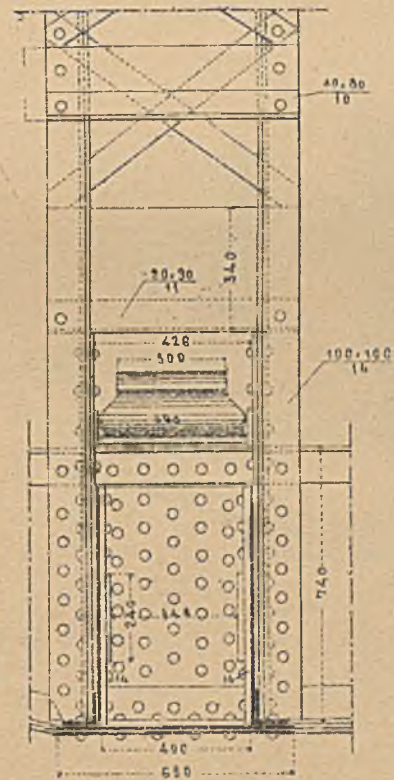

Przekroje

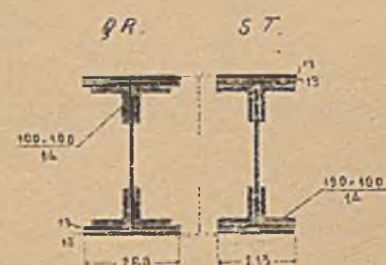
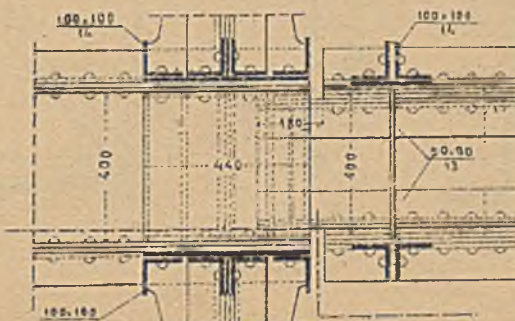

Paton. Mosty żelazne
tłom. str. 178.

Thullie

TEŻNIKI.

Rys. 1. Most blaszany baw. Kolei państwowych.

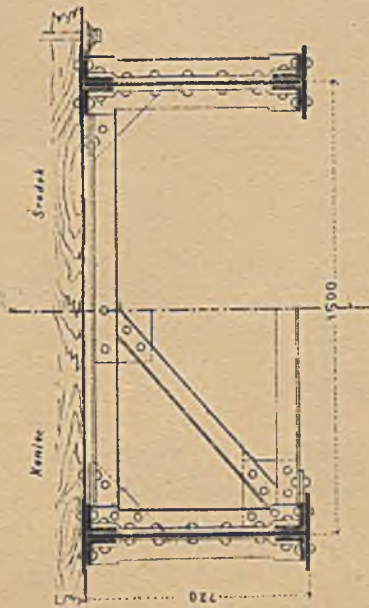

Rys. 2. Most na rzece Jpali na Węgrzech.

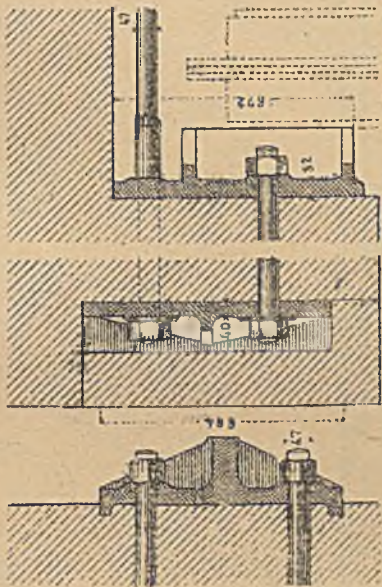

Rys. 3. Most drogowy pod Lawis w Tyrolu.

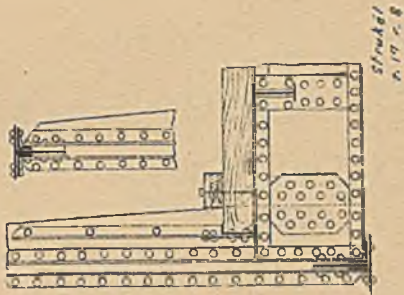

Rys. 4. Most na Lecku pod Kaufering.

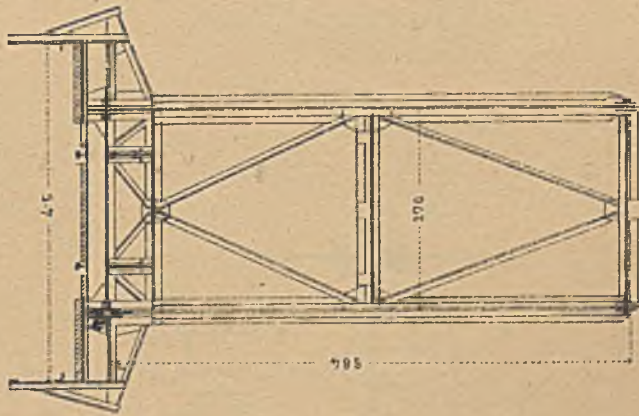

Rys. 6.

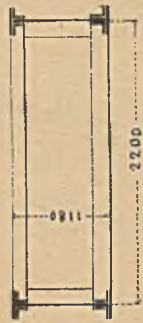

Rys. 5. Most w Souticich Czechy.

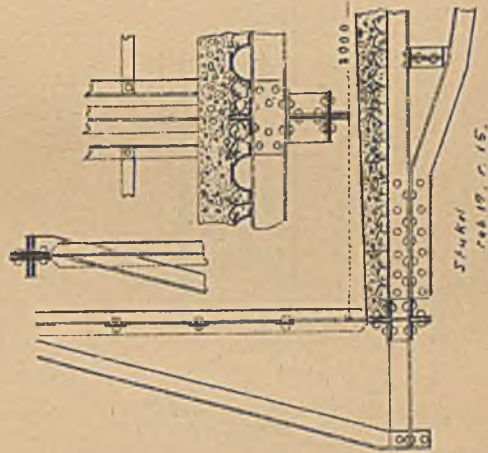

Rys. 9. Most na Brdzie w Bydgoszczy.

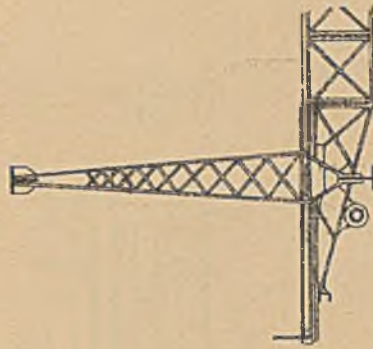

Rys. 8. Most Wiktoryi nad Jrwing

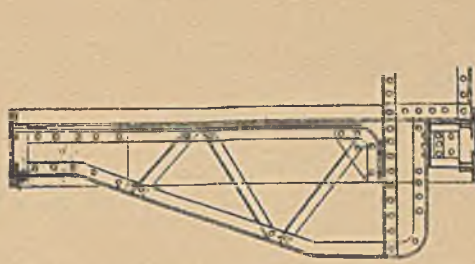

Thullie

RYS. 1. PRZEGUB
PRZY MIEJSKIM MOŚCIE NA WOŁDZE
W NOWOGRODZIE.

Rys. 1a.

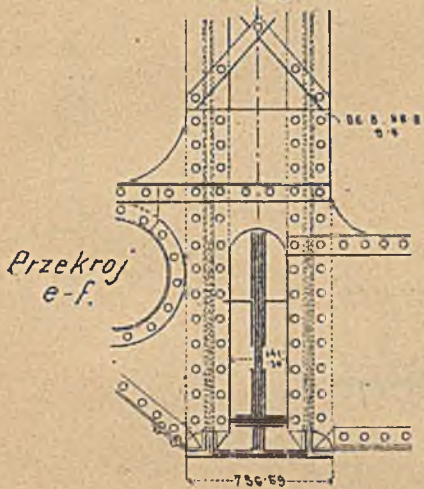
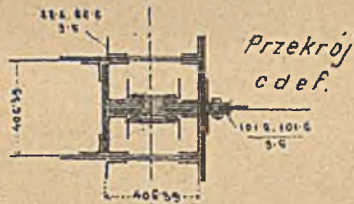
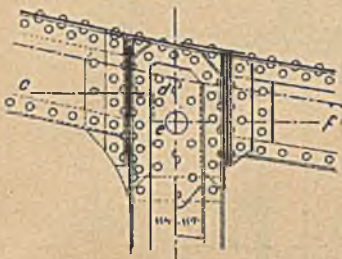

Rys. 1b.

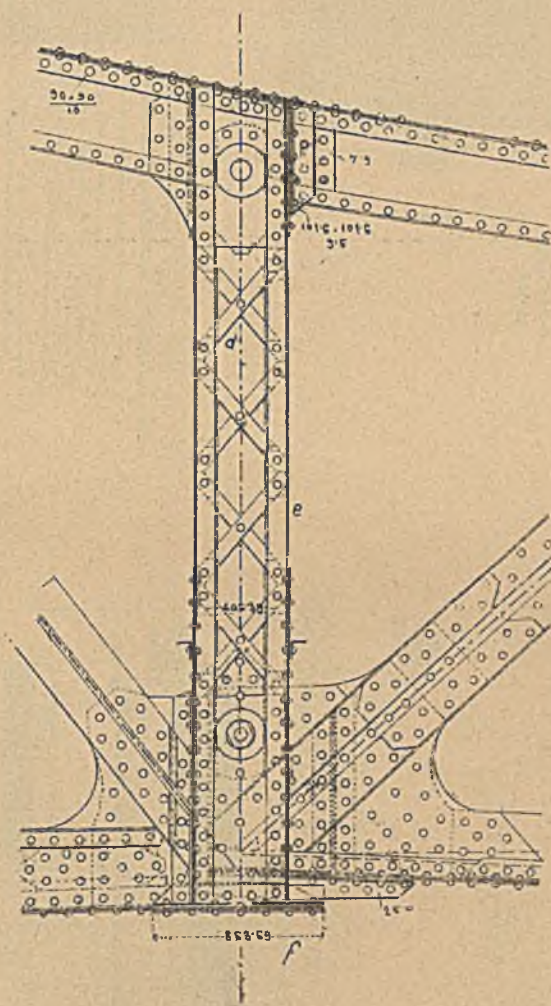

Rys. 1c.

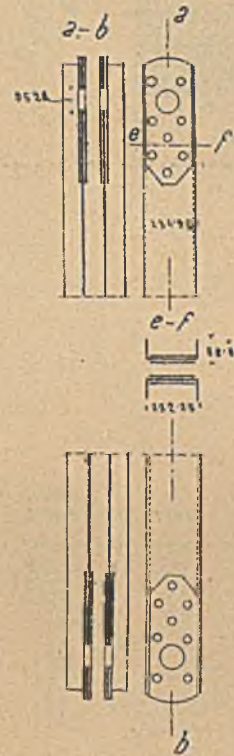

Paton tom II. 3187
ryc. 176.

Rys. 1d. Sworzeń.

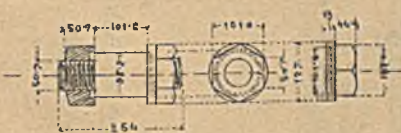

Rys. 1e.

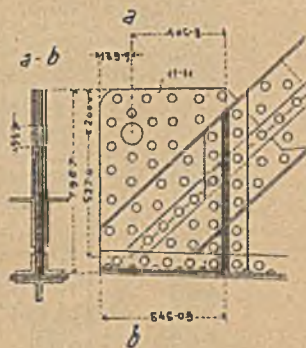

Rys. 2.
Wiadukt na Jgławie
pod Jwanczycami.
1/20 n.w.

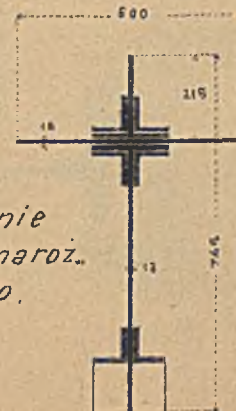

Stężenie
stupa naroż-
nego.

Rys. 3. Most w Chatillens
w Szwajcaryi.



Gesand
1. 1911. r. 116

M. Thullie

Winkler
st. 268
r. 189

ŁOŻYSKA.

Tab. 173.

Rys. 1. Most kolei
Moskiewsko-Jarosławskiej.

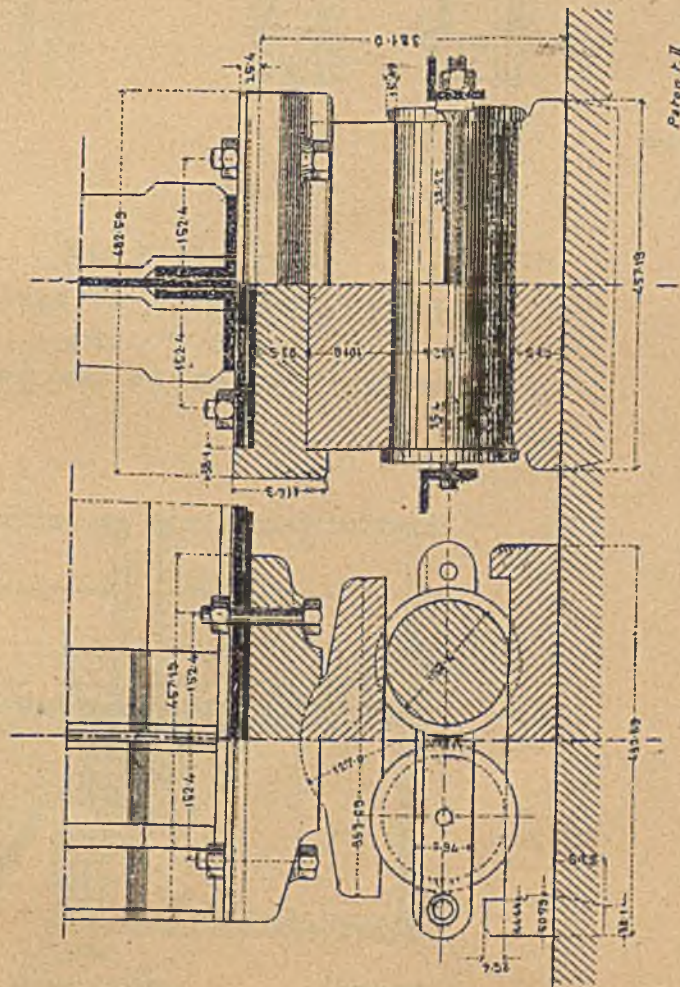

Patron T. II
cz. 116
c. 88 bit.

Rys. 2. Łożysko przy maście
na Weserze koło Gorvey.

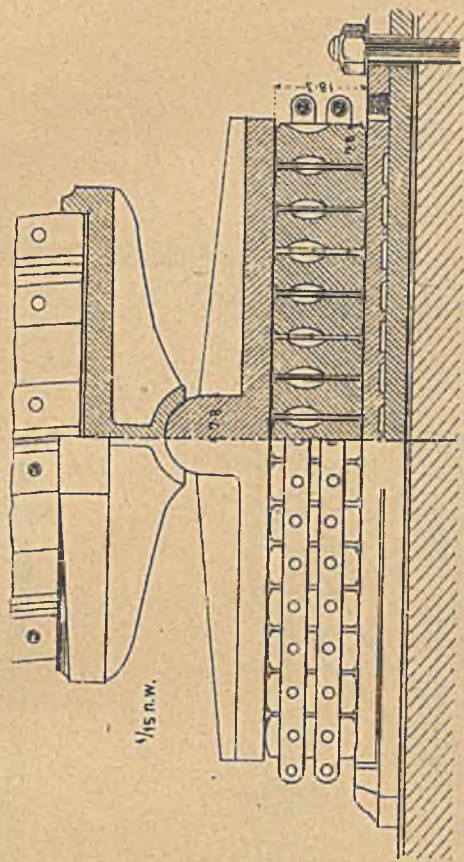

1/15 n.w.

125
n.w.

Wahler.
st. 259, c. 303.

Rys. 3. Łożysko stале rosyjskie.

Rys. 3b.
Widok.

Rys. 3a.
Widok boczny Przekrój
poprz.

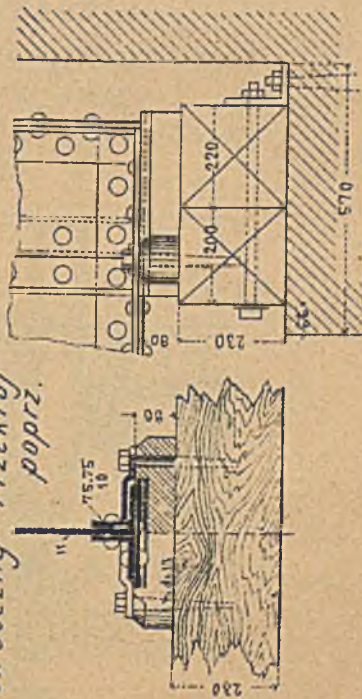

Patron G. I.
cz. 83, c. 25.

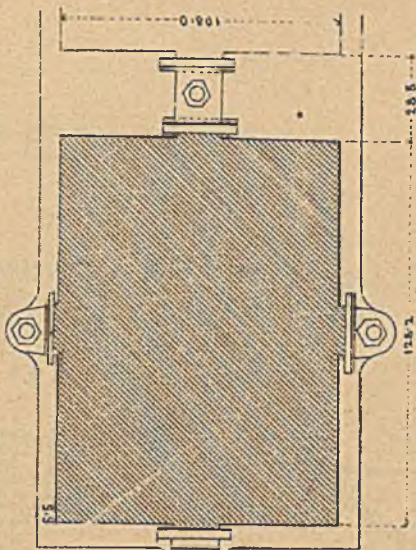

Rys. 4. Przegub mostu
na Nilu w Kairze.



D^c M. Thullie. Mosty kratowe zelazne.

Zestreb. d. arch. Ing. J. Arch. Ferriner 1905
nr 21, tab. 200, ryc. 5

Alm. K.

PRZEGUBY.

Rys. 1. Zakotwienie przy moście miejskim przez kanał Łaba -
-Trawa w Lubece [Burghorbrücke].

Rys. 1a.

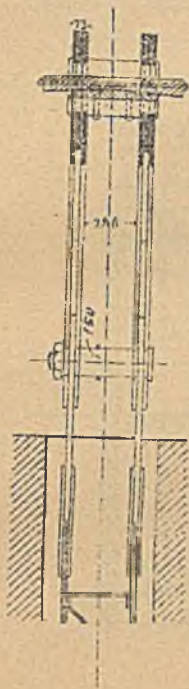

Rys. 1b.

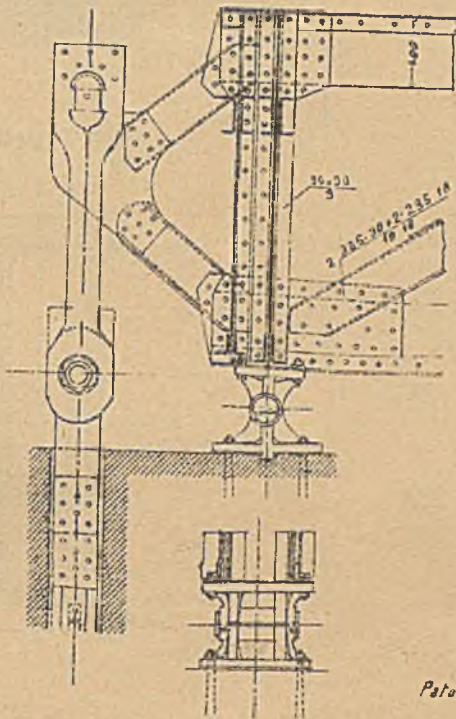

Rys. 1c.

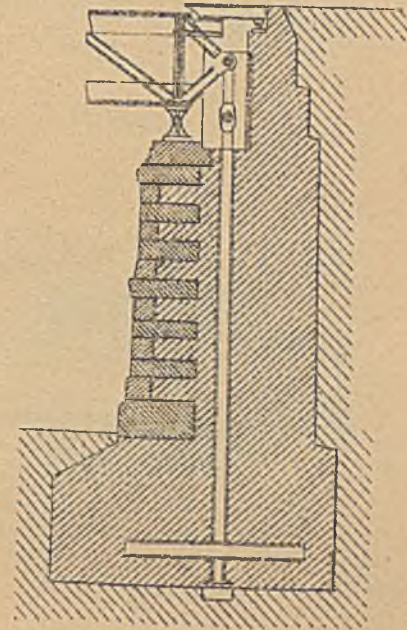

Patent tom II. str. 215. rys. 207.

Rys. 2. Przegub przy moście kolei południowo-
-Ussuryjskiej.
Rozpiętość podparowa 1280m.

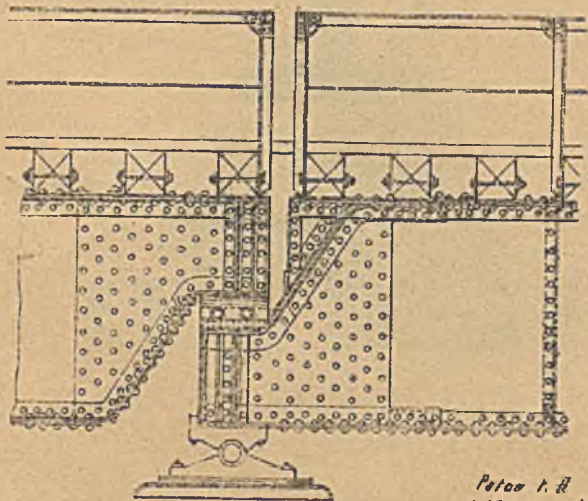

Patent I. R.
str. 187 rys. 164.

Rys. 3. Przegub przy
moście kolei południowo
Ussuryjskiej.
Rozpiętość podpor. 192m.

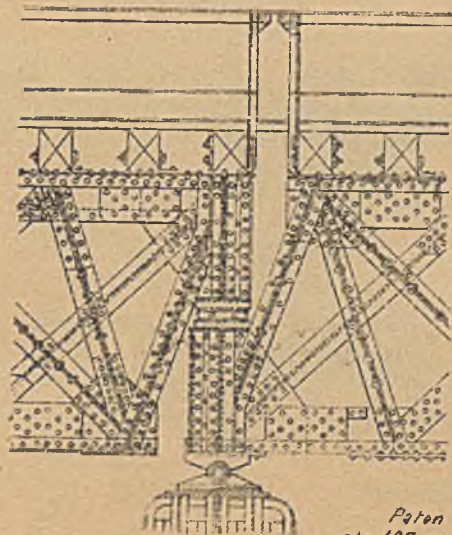

Patent
str. 167. rys. 155.

ŁOŻYSKA.

Rys. 1. Łożysko przy moście kolei wschodnio chińskiej
Rozpiętość podporowa 3200 m.

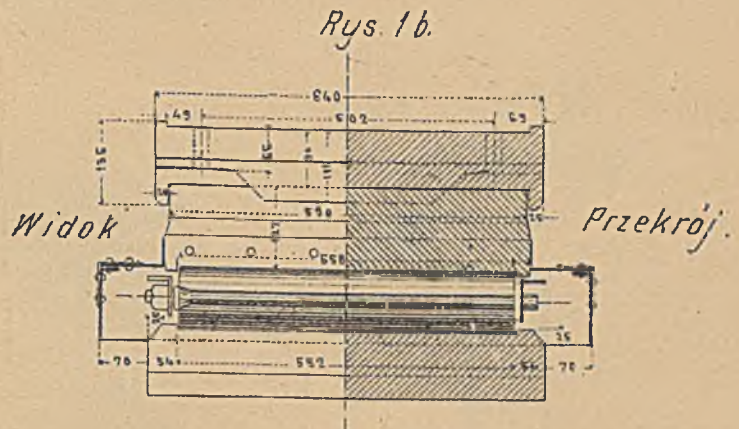
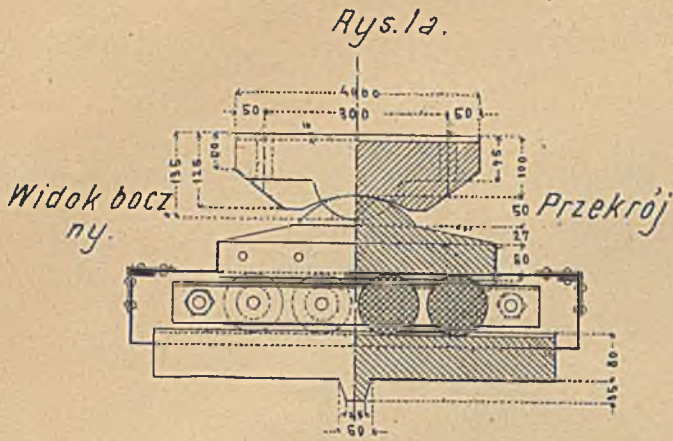

Rys. 1c. Rzut poziomy.

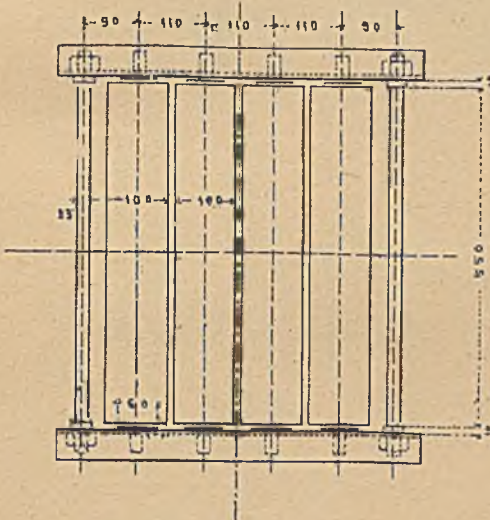

Rys. 1d. Widok z góry.

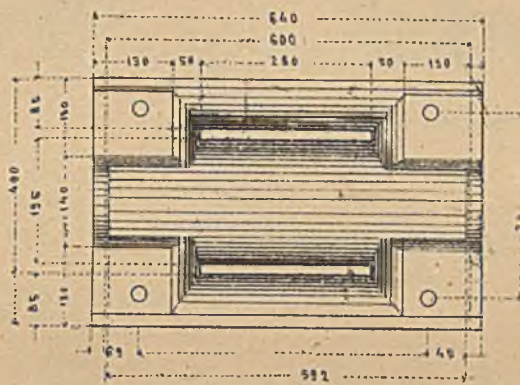

Patent. P. B.
nr 83, r. 46.

Rys. 2. Łożysko przegibne rosyjskie przy mostach kolei
połudn.-zachodnich i zaniemeńskich.

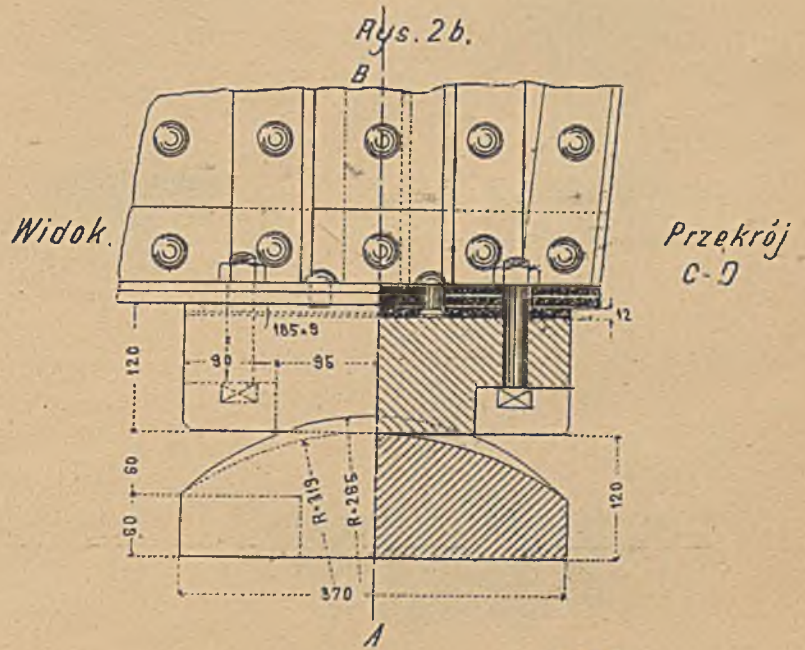
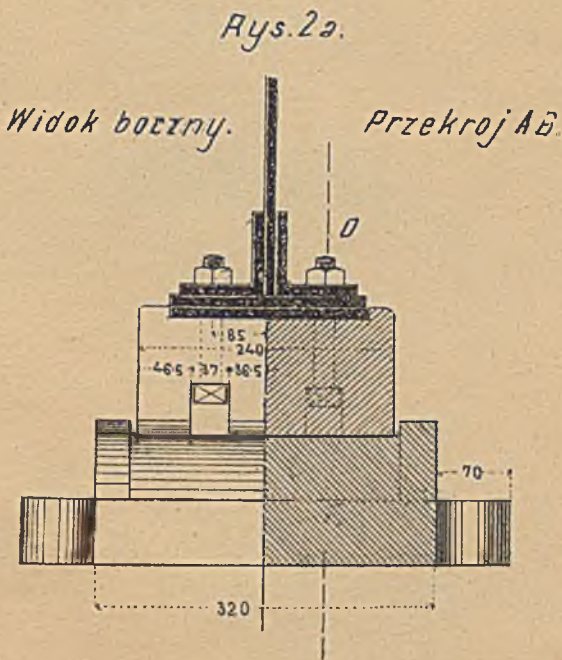

Patent. P. B. nr. 74 r. 35.

ŁOZYSKA.

Rys. 1. Zakotwienie przy moście na Wezerze w Hammelnie.

Rys. 1a.

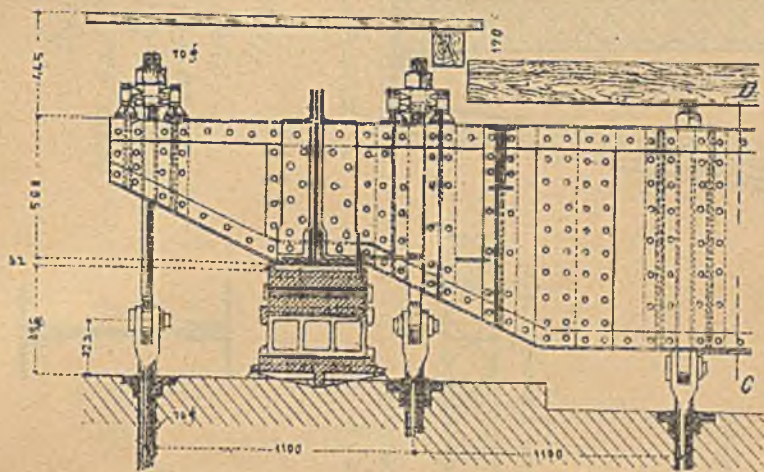

Rys. 1b.

Przekrój C-D.

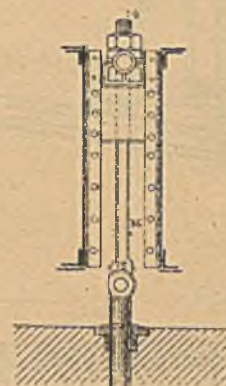

Patent tom II. str. 214 r. 206.

Rys. 2. Łożysko przy moście drogowym 53-34 m. rozpiętości na Zuszycy w Szejnie tulskiej gub.

Rys. 2a. Widok boczny

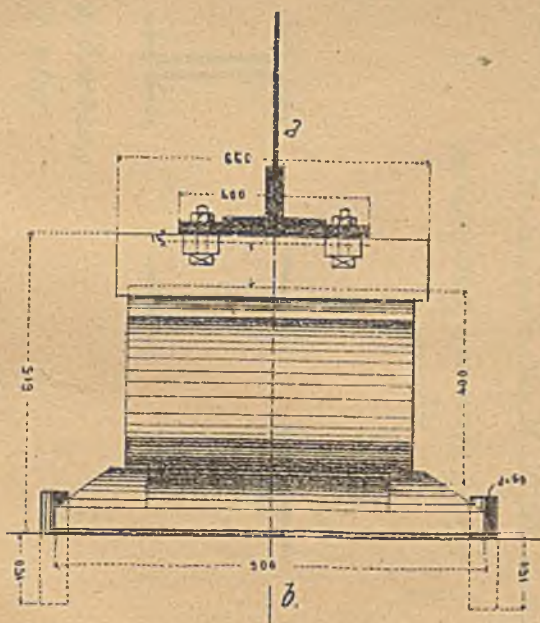

Rys. 2b. Widok.

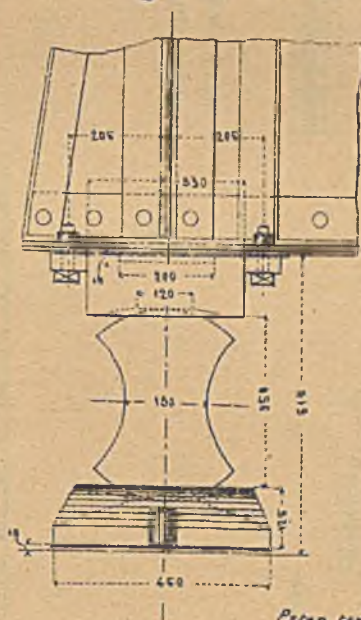

Rys. 2c. Przekrój a-b.

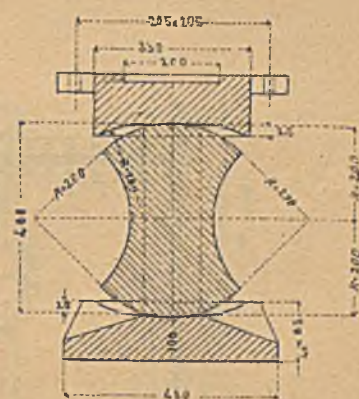

Patent tom II. str. 142 r. 114.

Rys. 3.

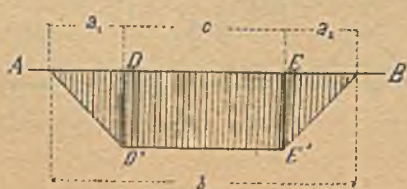

Rys. 4.

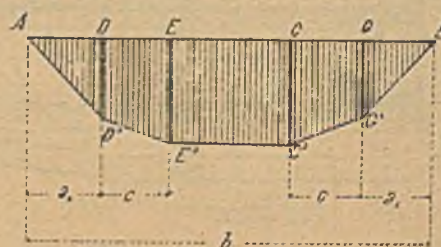

Thullie

TEŻNIKI.

Tab. 177.

Rys. 1.
Most na Salicy między
Oberndorfa Laufen.

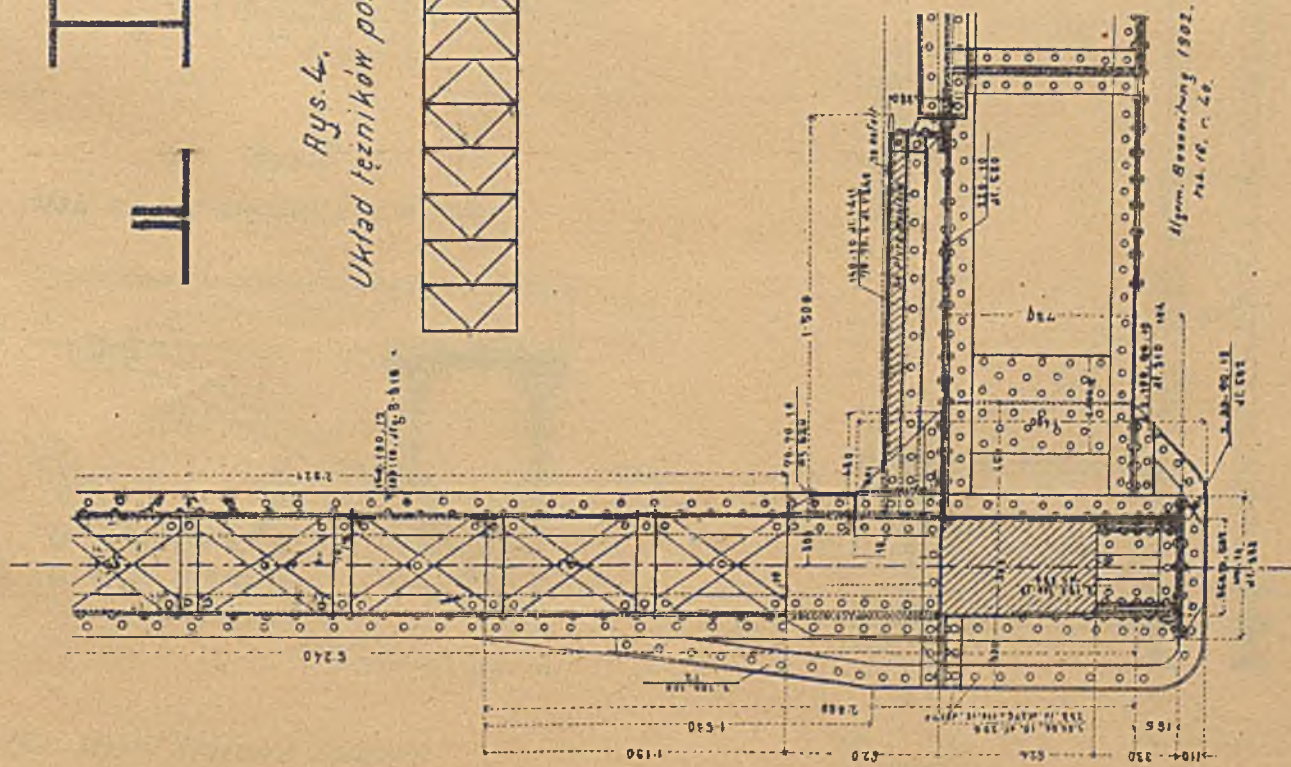

Rys. 2.
Przekroje rozpór.



Rys. 3.
Most nad Paraguassa
między Chachocirą
a Sao-Felix w Bra-
zylji.
1/15 n.m.

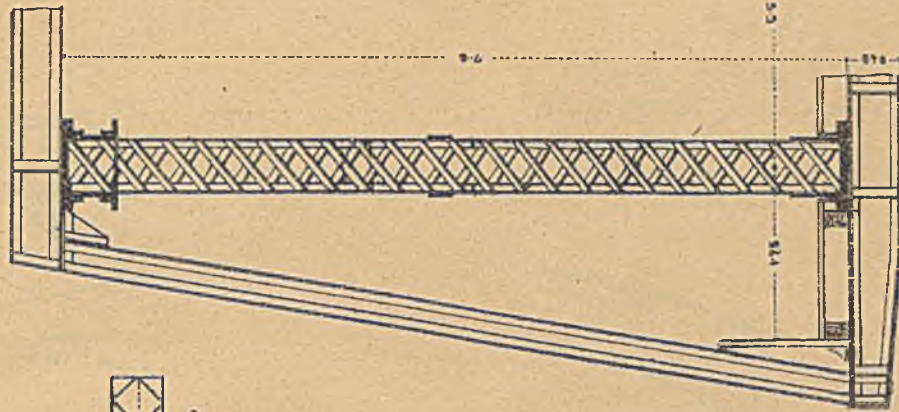

Rys. 4.
Układ łożników poziomych.



Rys. 5.

Kładka cesarska
w Oberschöneweide.



Zeich. J. Baumann 1900
nr. 74.

Rys. 6.
Most na Litawce na drodze
Rakownicko-Protiwiskiej.

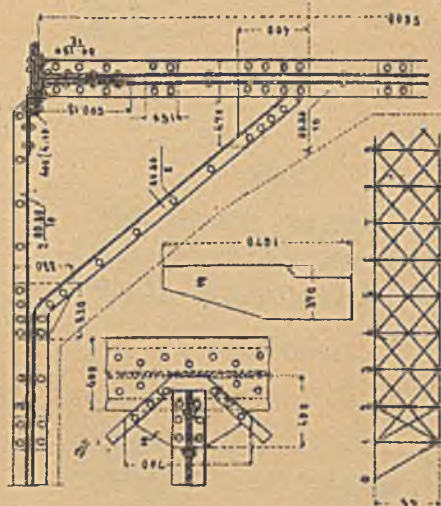

Hgen. Bauzeichnung 1902.
Bl. 16, n. 46.

Zeich.
nr. 866, n. 573.

Wisklar
nr. 291, n. 318.

Dr. M. Thullie. Mosty kratowe żelazne.

Thullie

Rys. 1.

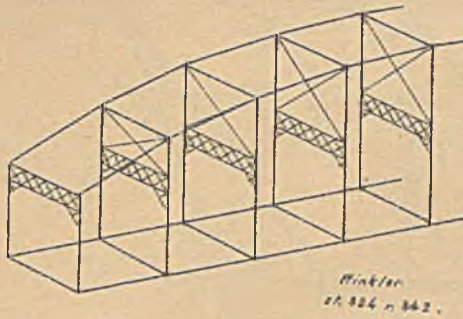

Winkler st. 324 n. 342.

Rys. 2.

Rozpora podwyższona przy moście na Tamizie pod Blackfriars.

1/36 n.w.

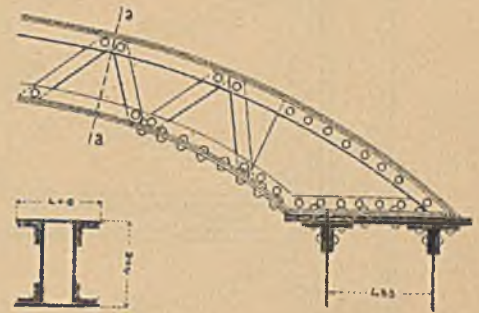

Winkler st. 273, n. 321.

Rys. 3.

Most nad Szana-Tobel kolei arulańskiej.

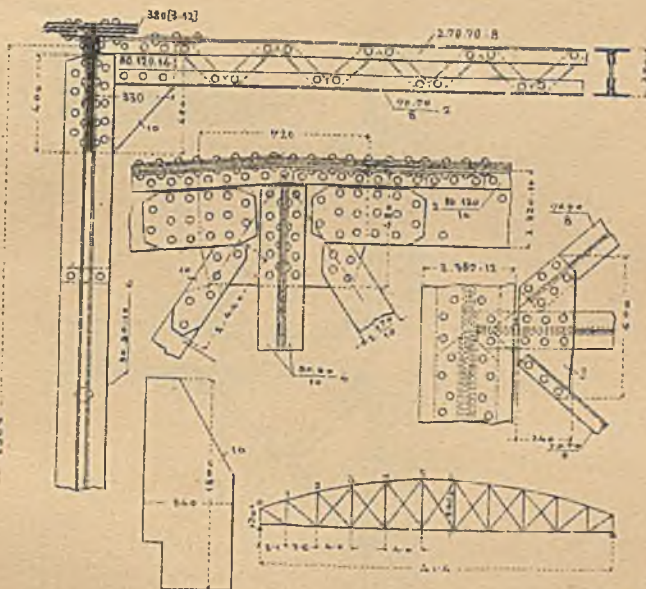

Velarik A 358, n. 518.

Rys. 4.

Połączenie rozpory ze słupami przy moście na Odrze w Szczecinie.

1/40 n.w.

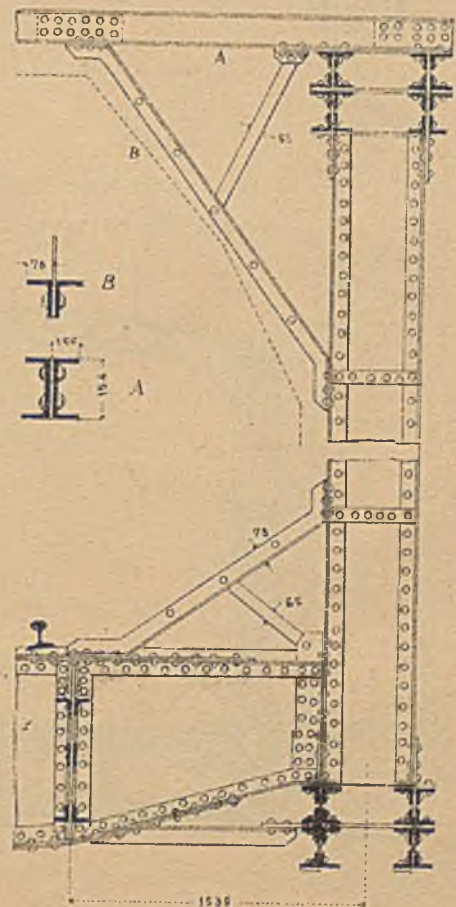

Winkler st. 274, n. 323.

Rys. 5.

Most na Lahn pod Lahnstein.

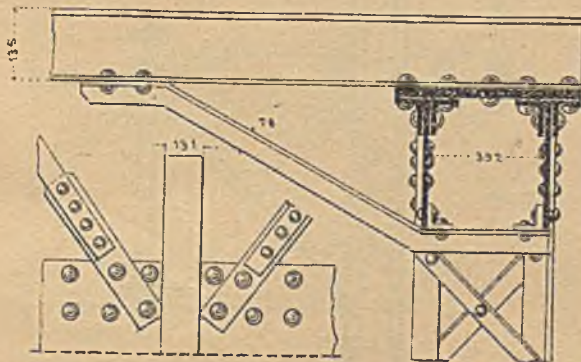

1/25 n.w.

Winkler st. 272, n. 318.

TEŻNIKI.

Rys. 1.
Most na Wezerze pod Corvey. 1/150 n.w.

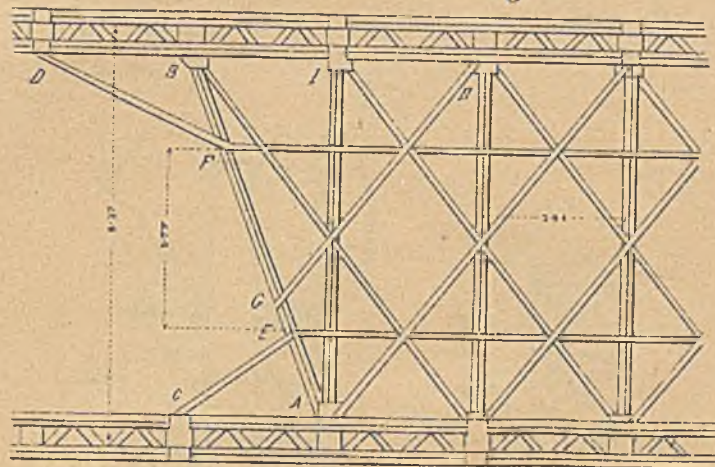

Rys. 2.
Most na Lecku pod
Kuilenburgiem.

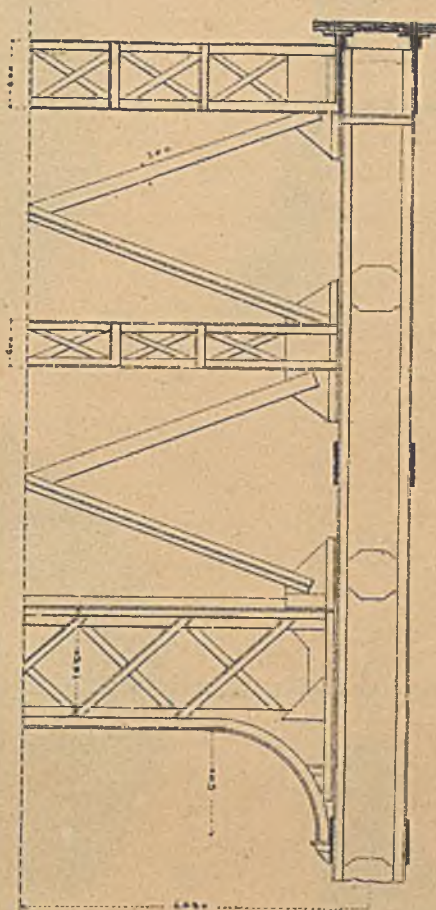

Rys. 3.
Most na Minnesund koło
Minny w Norwegii.

Winkler
st. 292, n. 306.

1/100
n. w.

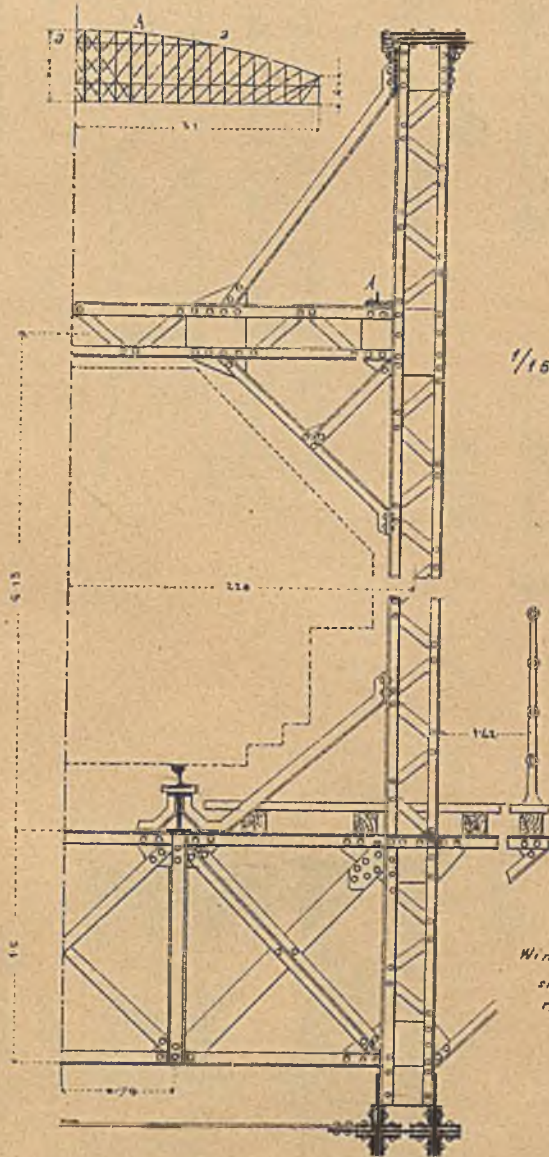

1/15 n.w.

Winkler
st. 283
n. 341.

Rys. 4.
Most nad dworcem
Elżbiety w Wiedniu.

Winkler
st. 278, n. 321

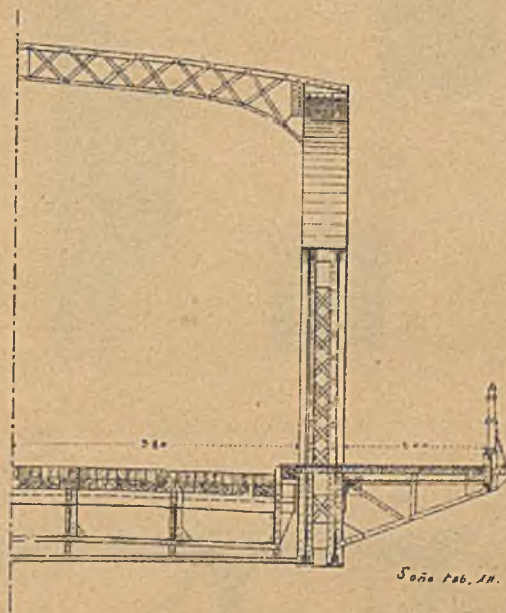

Soňa tab. 11.

TEŻNIKI

Rys. 2.
Tężniki przy środkowym przęśle mostu na Forth.



Maszyn. nr 536 n. 785

Tężniki poziome.

Rys. 5.



Rys. 4.



Rys. 3.

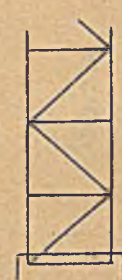

Rys. 1.
Most na Kampie w Górnej Austrii.

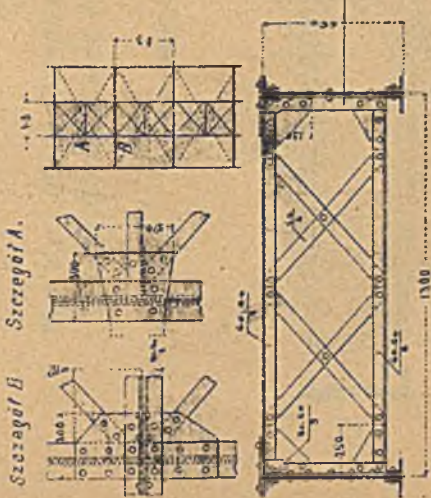

Fe 17/18 nr 343 n. 446.

Rys. 6.
Most na Uleå-Elf koto Uleåburgu w Finlandyi.



Druckerei 186. 18. 12.

Rys. 7.

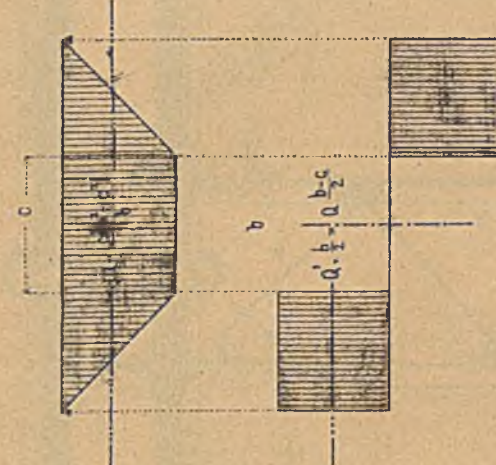

Rys. 8.

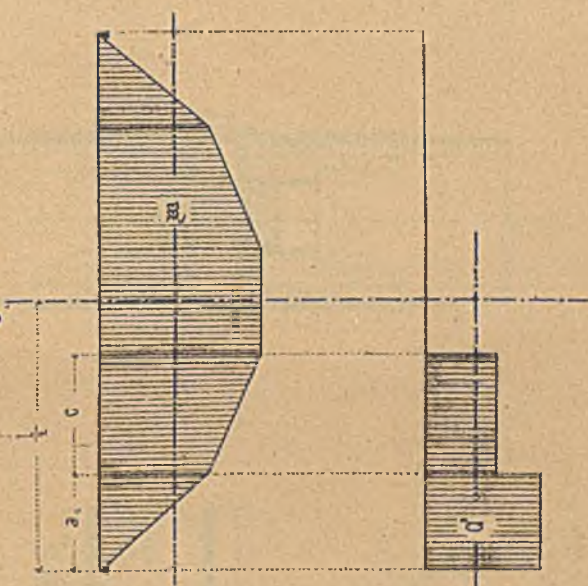

Rys. 9.

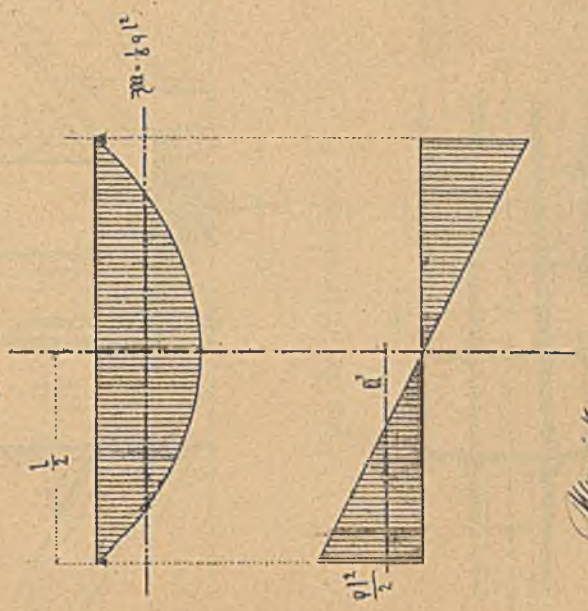

Wassner

Dr. M. Thullie. Mosty kratowe zelazne.

TEŻNIKI.

Rys. 1.

Rys. 1a. Most drogowy na Amizie pod
Tunxdorf. Kanat Dortmund-Amiza.

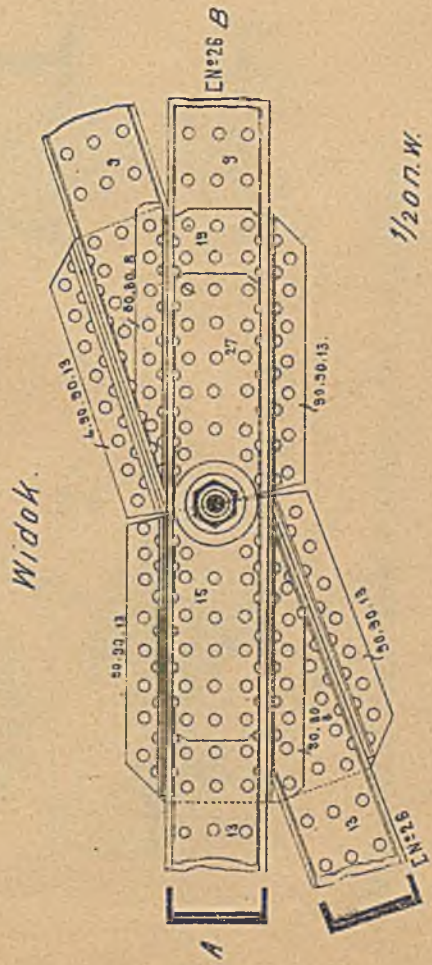

Rys. 1b Przekroj A-B.

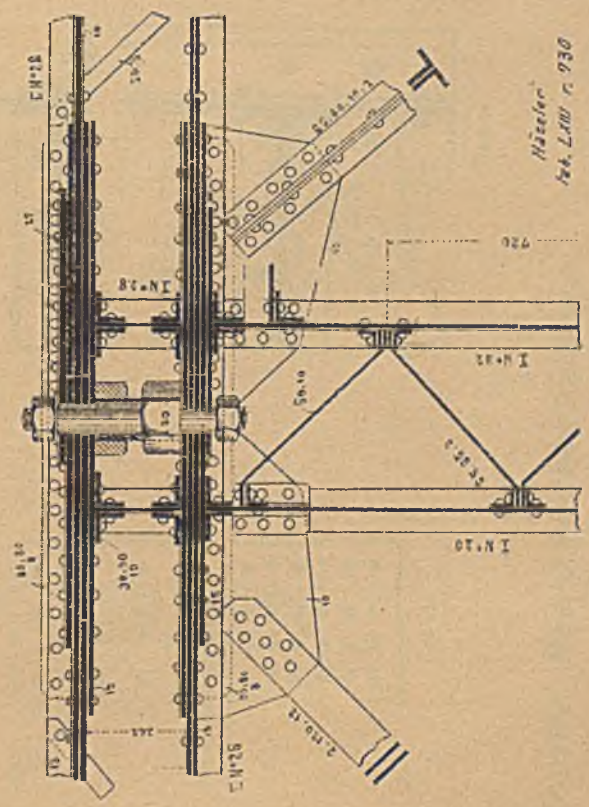

Dr. M. Thullie. Mosty kratowe żelazne.



Rys. 2c.

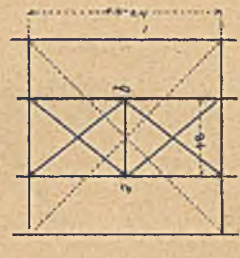

Rys. 2b

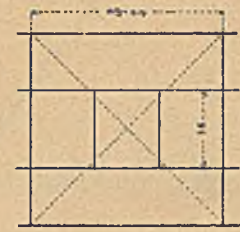

Rys. 2. Teżniki między podłużnicami.

Teillich
nr. 339, n. 429

Teillich
nr. 339, n. 628.

Rys. 3. Teżniki mostu na Forth.

Rys. 3a. Przekroj C-D.

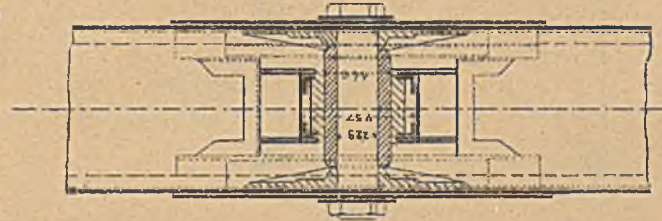

Rys. 3b. Przekroj A-B.

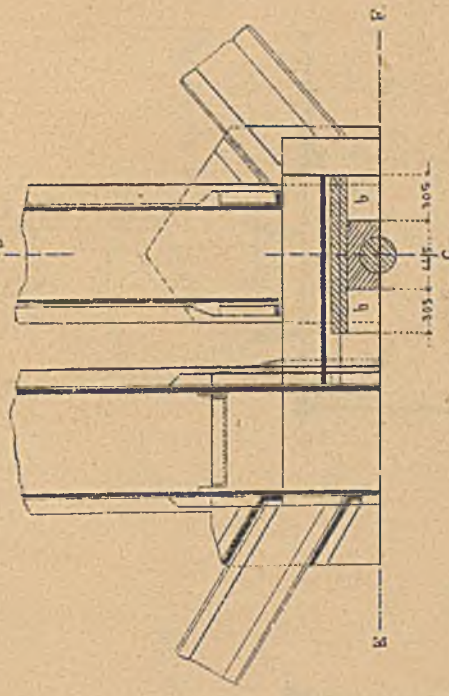

Rys. 3c. Przekroj E-F.

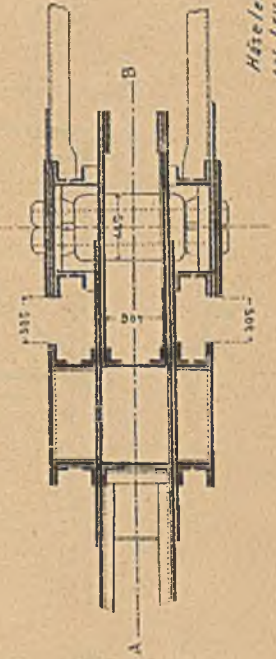

Häsel
Tab. LXXI, n. 916

Thullie

TEŻNIKI.

Rys. 1.

Most na Elbie pod
Niederwartha.

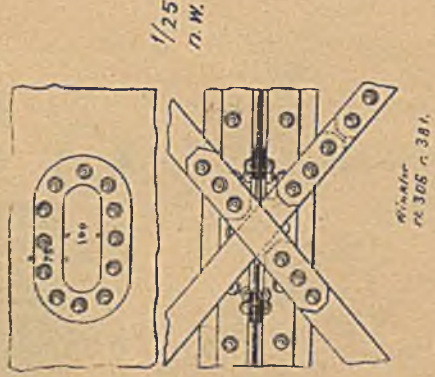

Rys. 2.

Most drogowy na Menie
pod Wertheim.

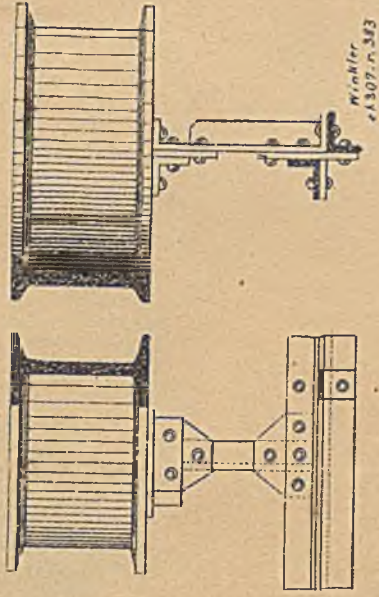

Rys. 3.

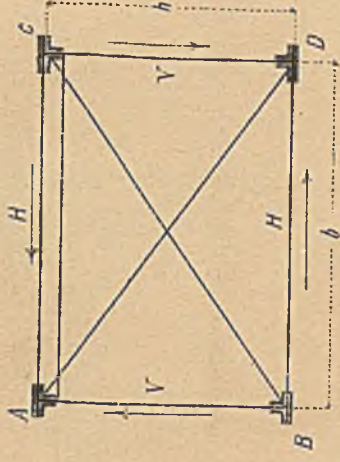

Sily zewnętrzne
działające na teźniki poprzeczne.

Rys. 4.

Most na Jinnie
w Passawie.

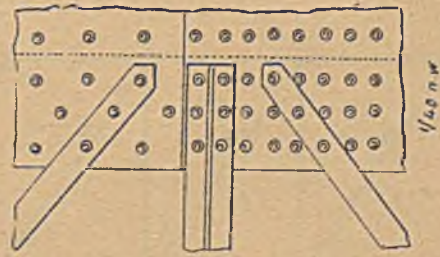

Rys. 5.

Połączenie teźników poziomych z belkami.

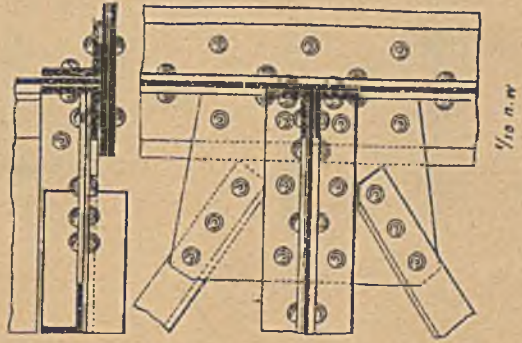

Rys. 6.

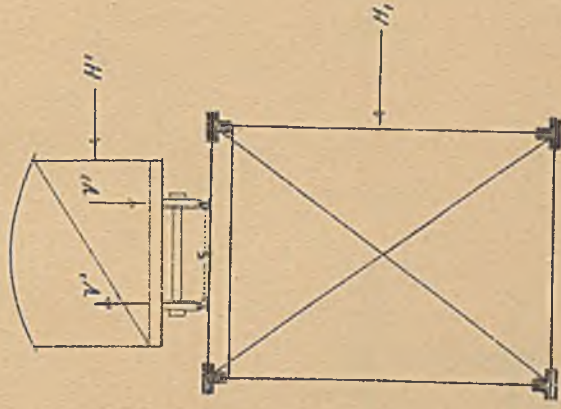

Rys. 7.

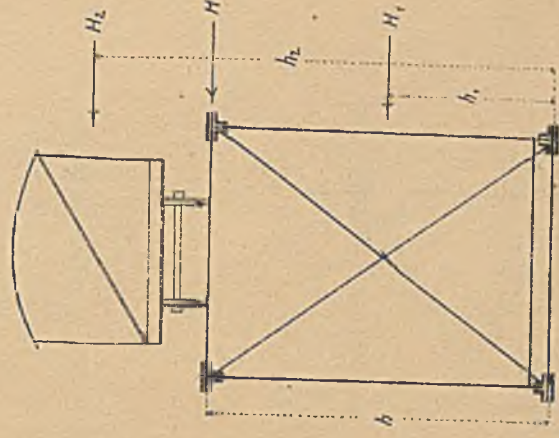

DE. M. Thullie. Mosty kratowe żelazne.

Manuscript

TEŻNIKI.

Rys. 1.

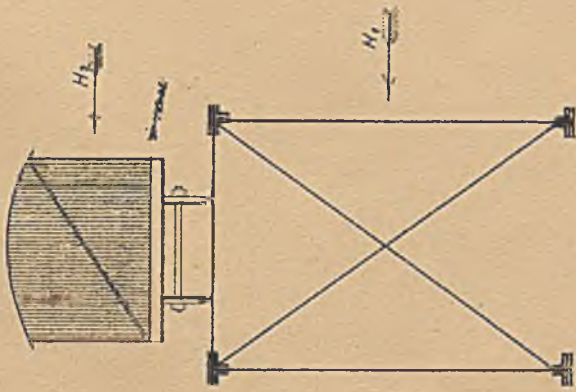

Rys. 2.

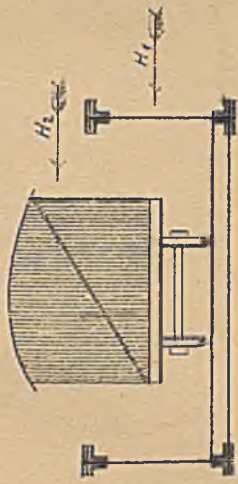

Rys. 3.

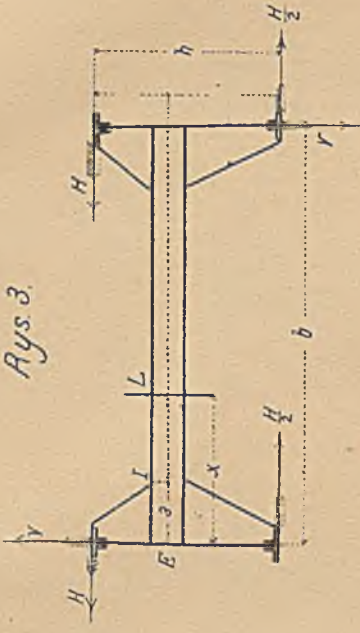

Rys. 5.

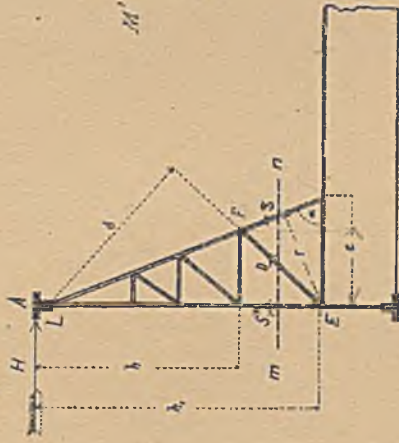

Rys. 9.



Rys. 6.

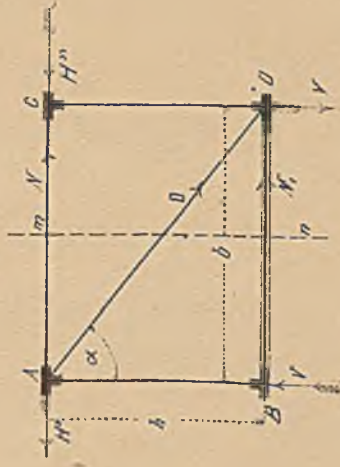

Rys. 4.

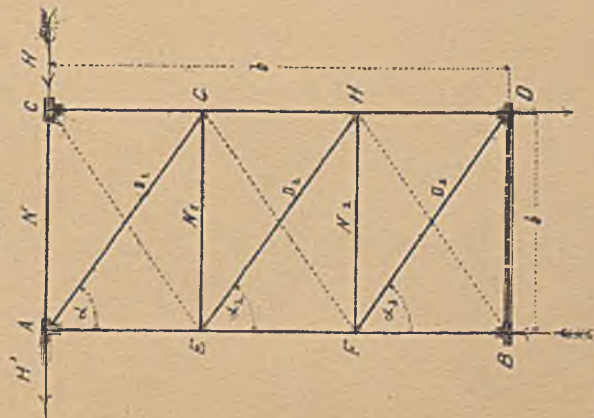

Rys. 7.



Rys. 8.

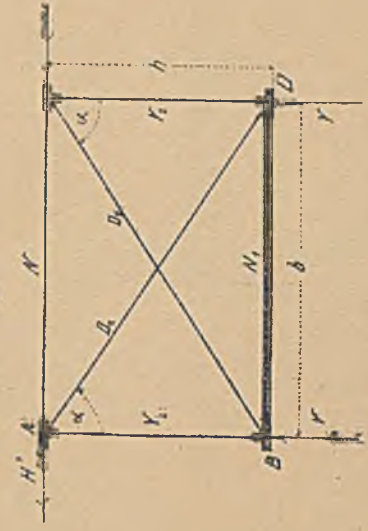

TEŻNIKI.

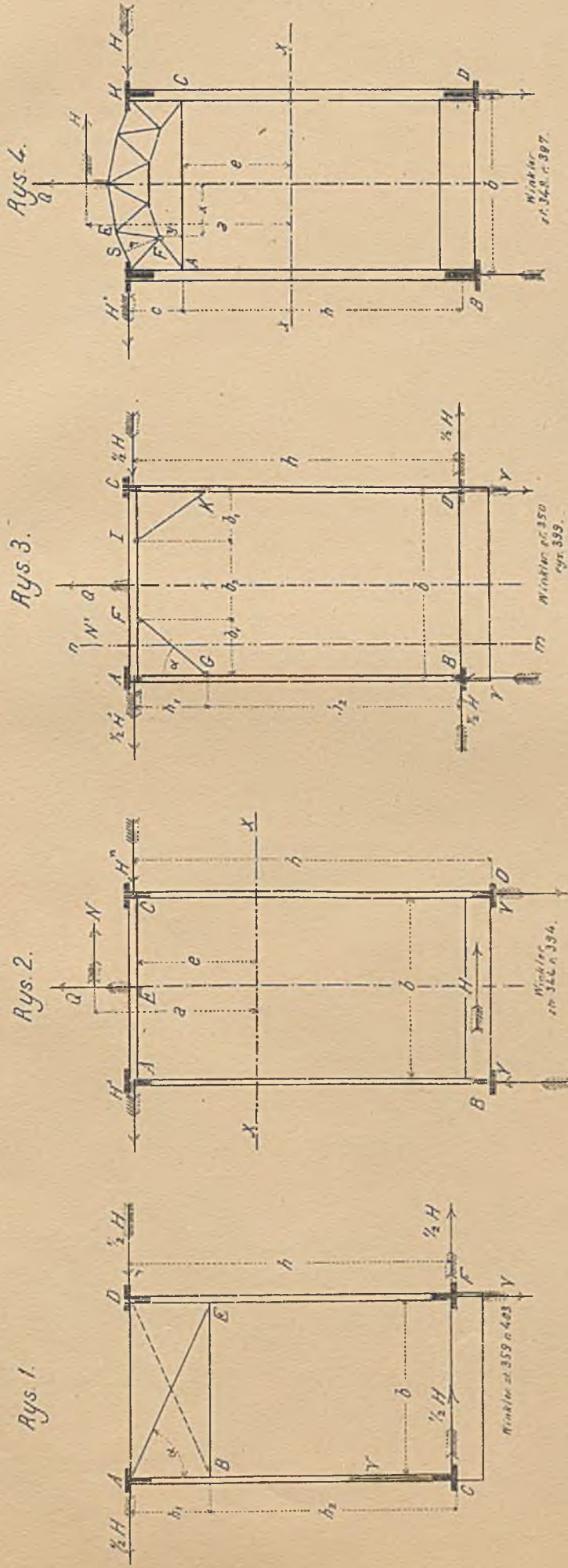

Rys. 7.
Most na rzece Ruhr koto
Frömdenbergu.

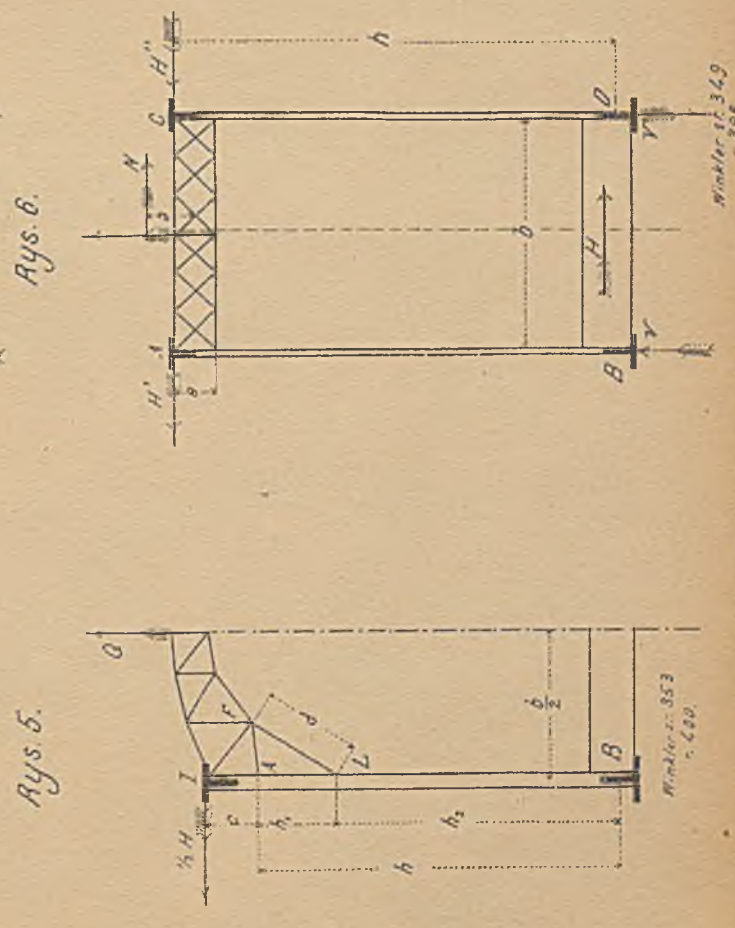
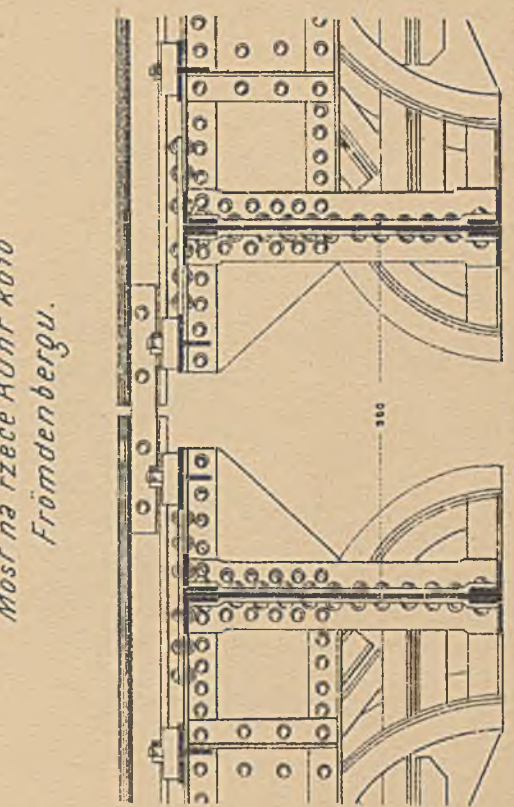

Winkler

Dr. M. Thullie, Mosty i mostowe żelazne

ZAKOTWIENIE MOSTU JAZOWEGO NA WELTAWIE W MIRZOWICACH

Rys. 1.
Przekrój podłużny A-B do fig. 3.

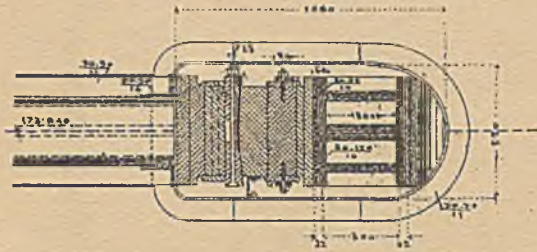

Rys. 2. Widok boczny filaru z zakotwieniem.

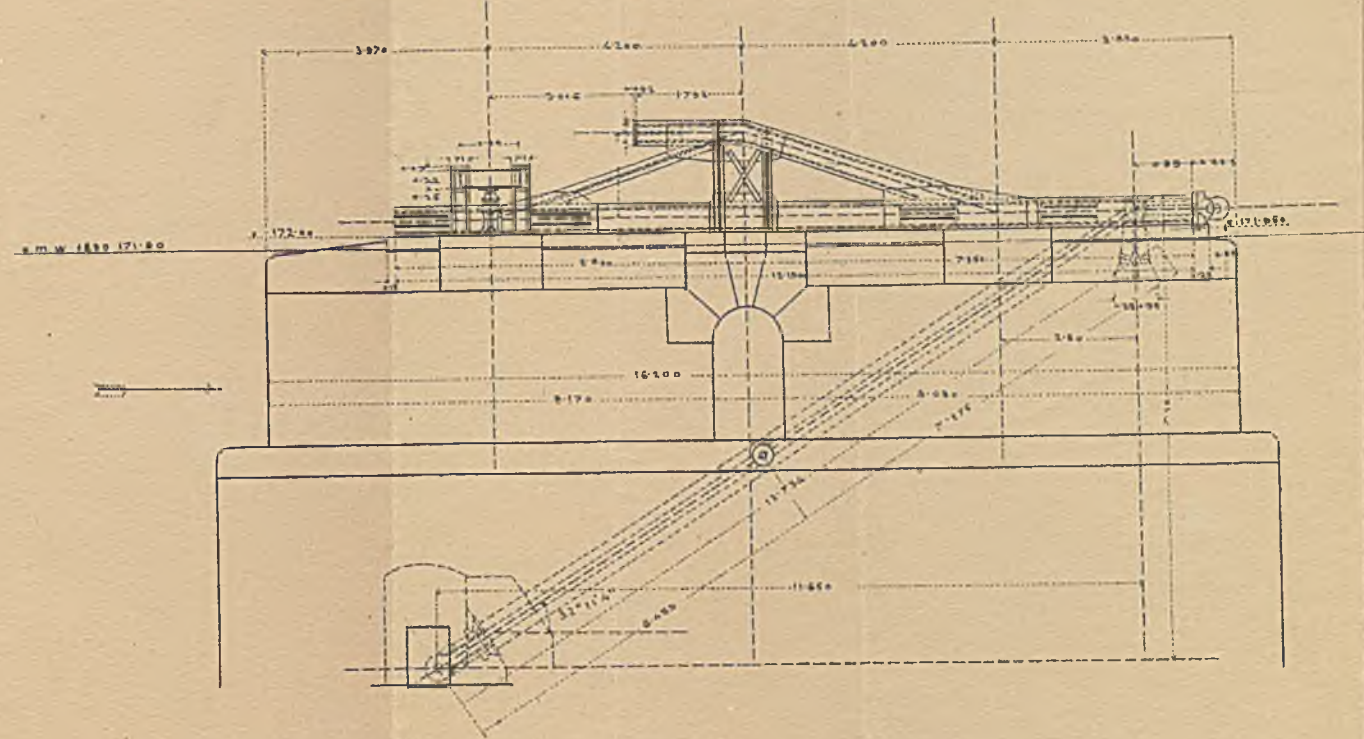

Rys. 3. Łożysko pionowe.

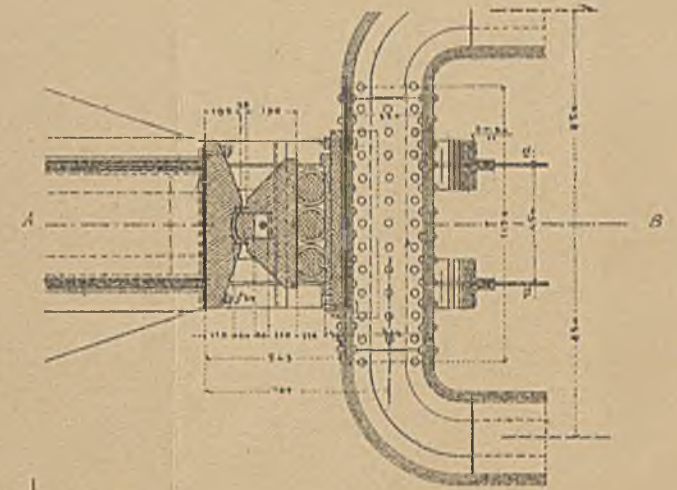

Rys. 4. Przekrój poprzeczny mostu jazowego przez filar.

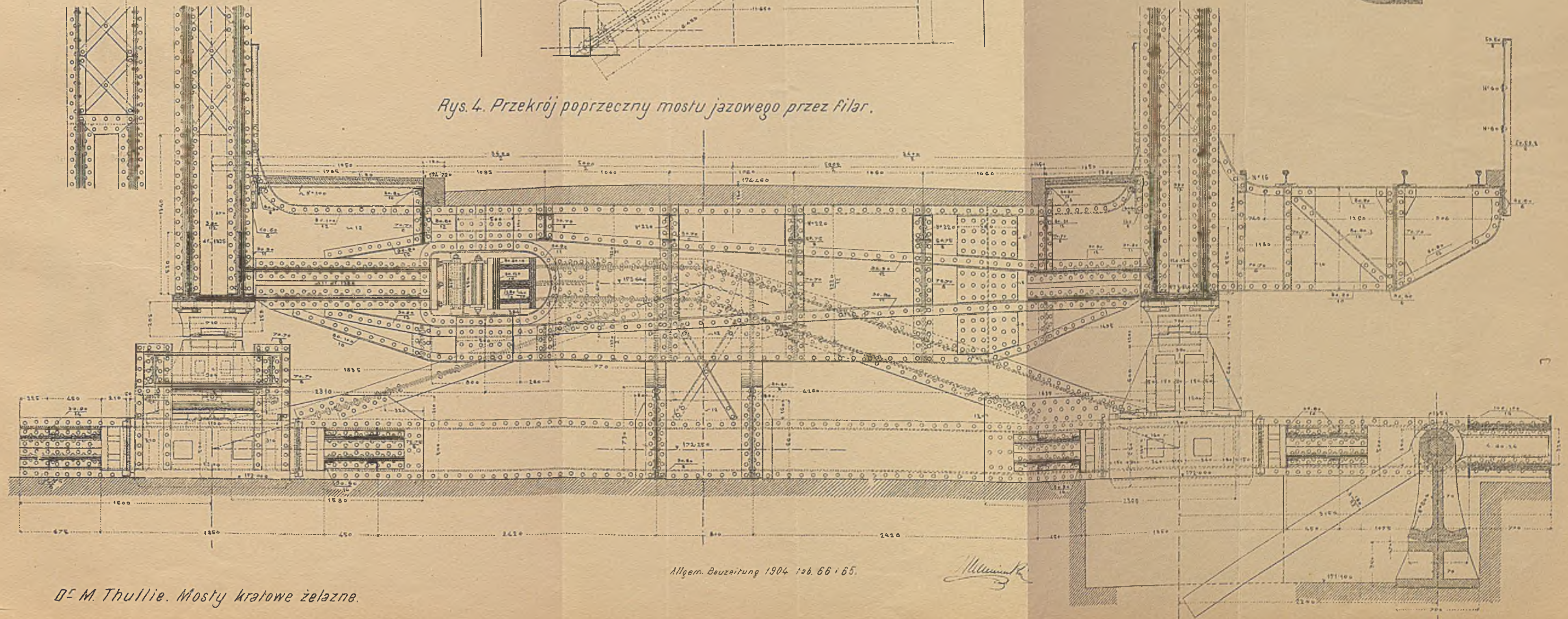

Allgem. Bauzeitung 1904 108. 66 i 65.

Thullie

DOKŁADKI MOSTOWE.

Rys. 1.

Dokładka nakładkowa.



Winkler
nr. 466 n. 446

Rys. 3.

Dokładka z podporą przy moście
na Mozie koło Hedel.

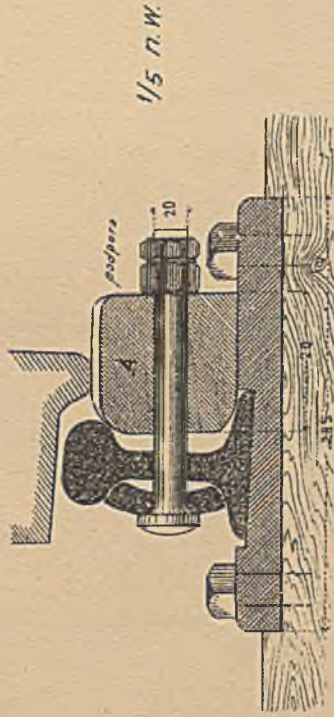

1/5 n.w.

Rys. 4.

Most na Waal pod Bommel w Ho-
landyi

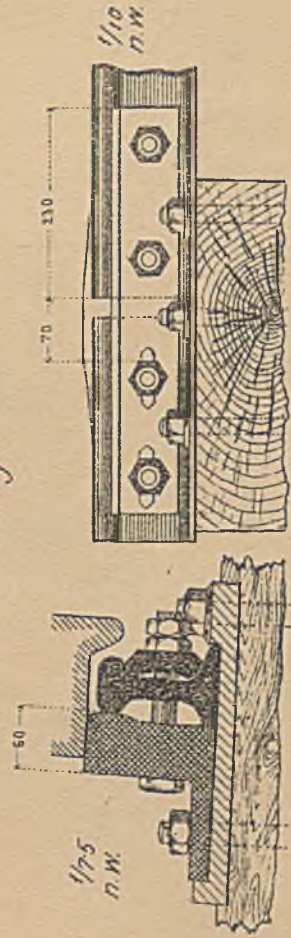

1/75
n.w.

Winkler
nr. 468 n. 450

Rys. 2. Most na Dunaju koleji
północnej.

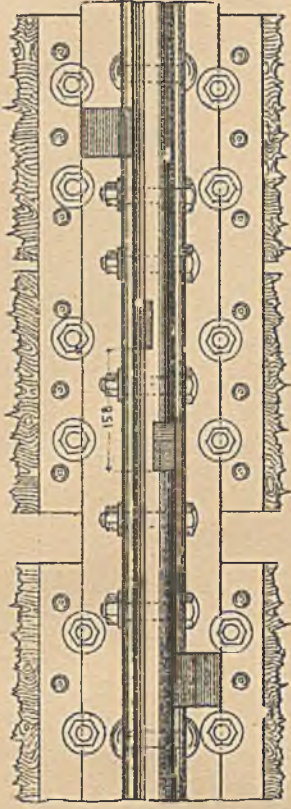

1/10
n.w.

Winkler
nr. 467 n. 448

1/5
n.w.

Rys. 5.

Most kolei połudn. austr. [Paulus]

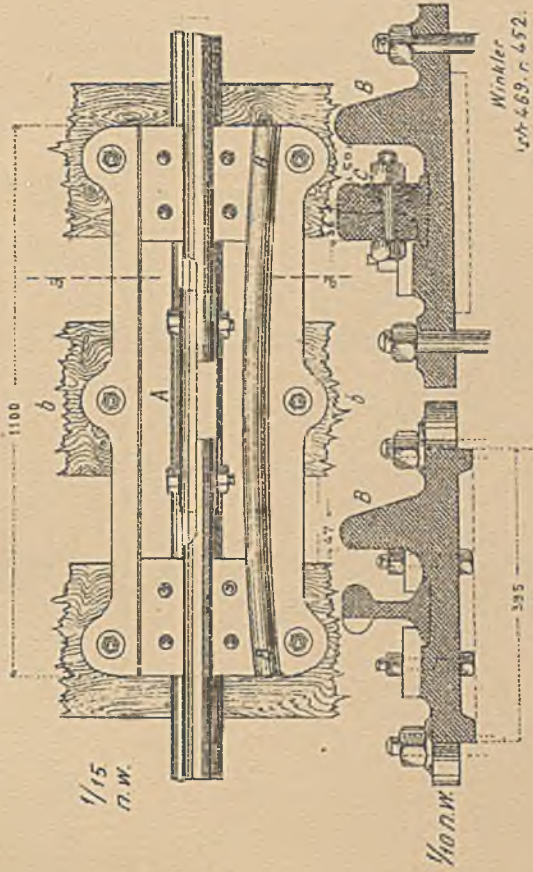

1/15
n.w.

Winkler
nr. 469 n. 452

Dr. M. Thullie. Mosty kralowe zelazne.

MOSTY W SPADZIE.

Rys. 1. Most na Kapftobel w spadku 4,6%.

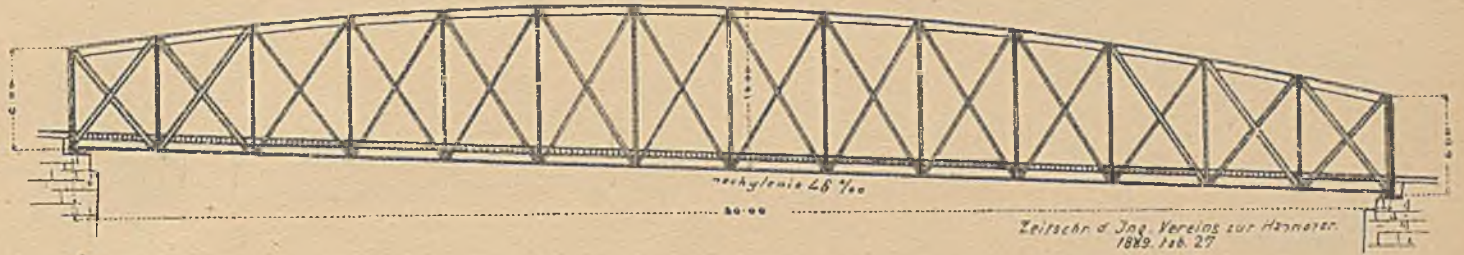

Rys. 2. Zakotwienie pasu górnego przy moście drogowym nad wiaduktem Nocą pod St. Guistina

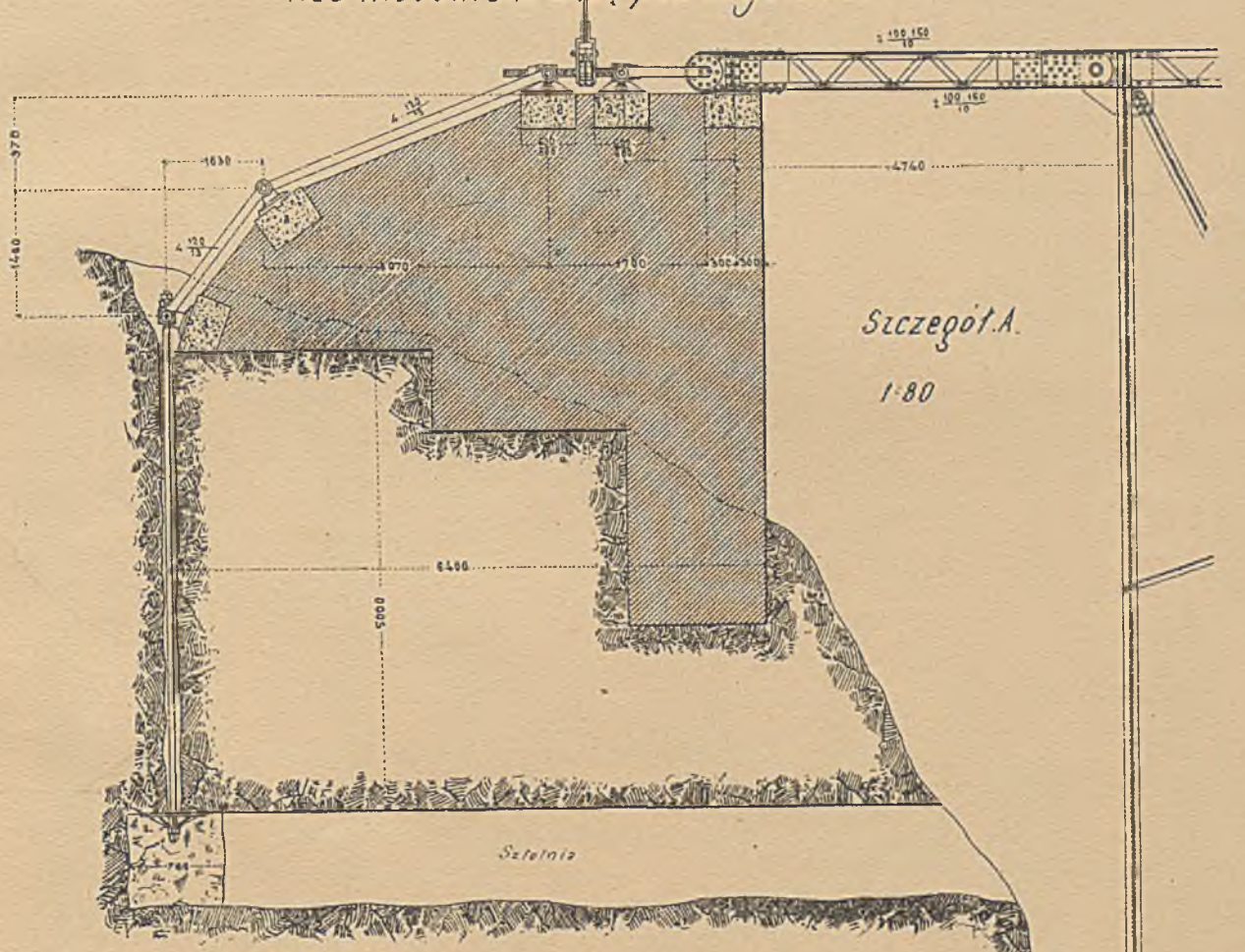

Rys. 2b. Widok.

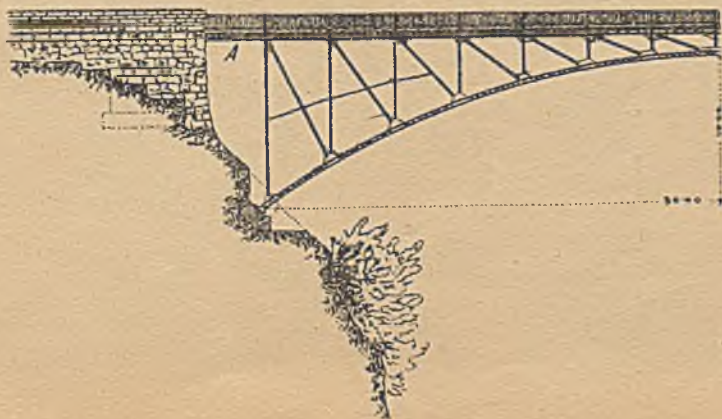

Zeitschr. d. österr. Ing. u. Arch. Vereins
1889. Jah. XVI. VII.

Müller

MOSTY W SPADZIE.

Rys. 1. Most koło Rawenny.

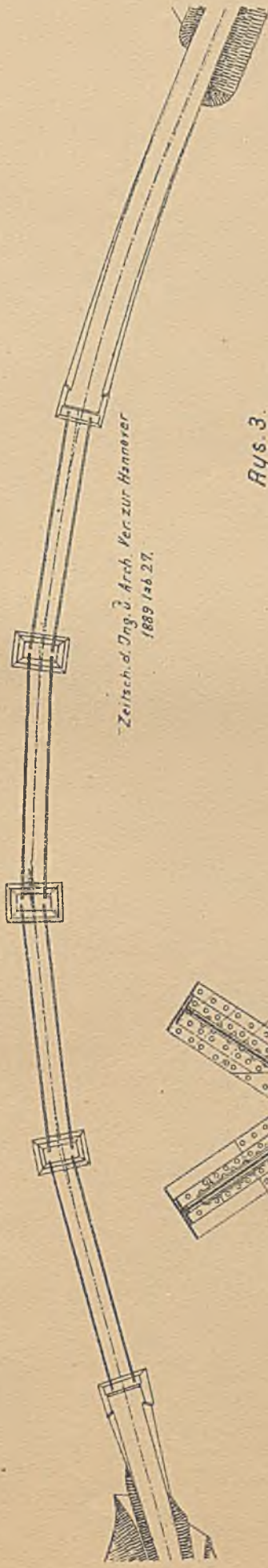
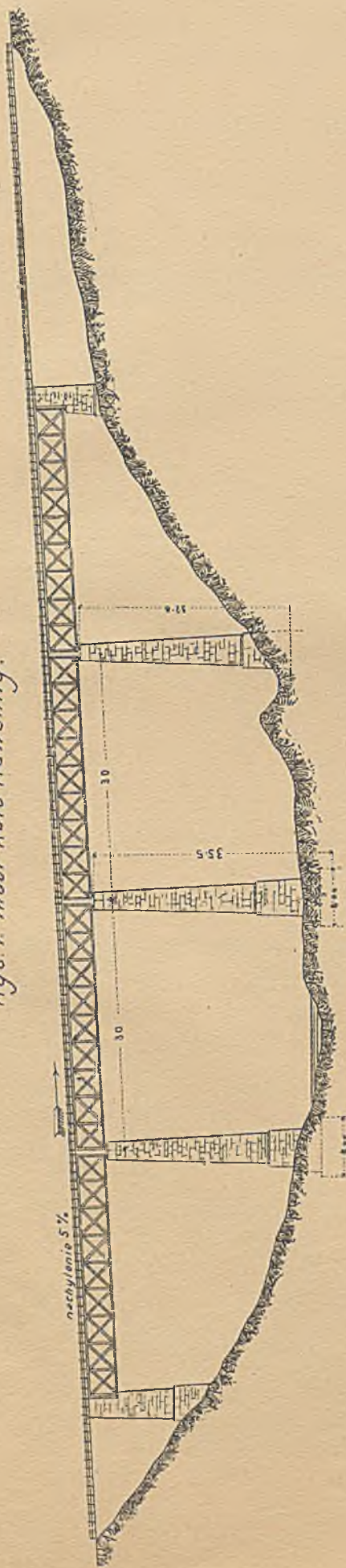

Zeitsch. d. Ing. u. Arch. Von zur Harnhor
1889 Tab. 27.

Rys. 3.
Most na Wiśle pod
Toruniem.

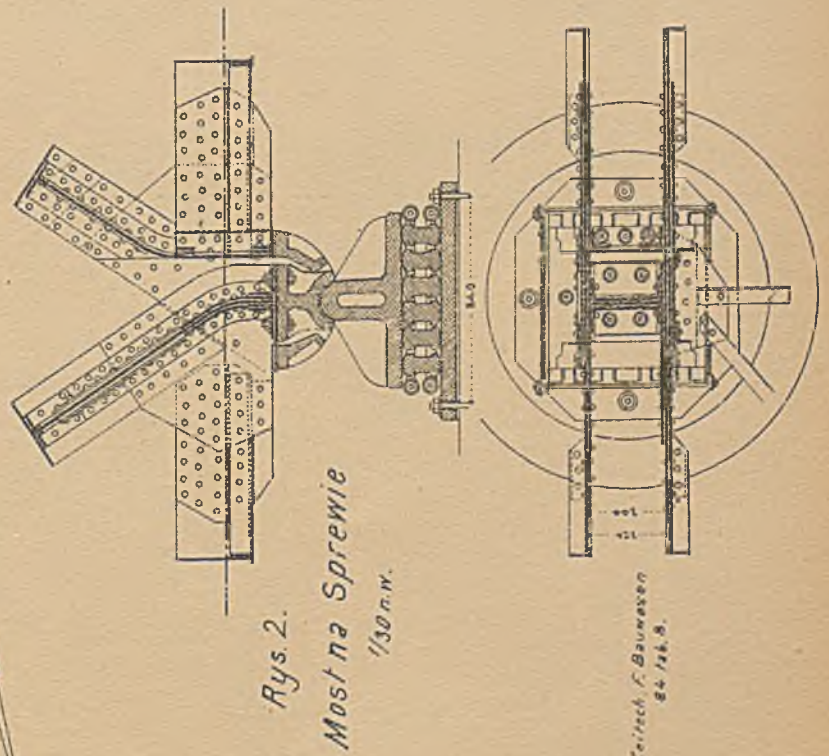

Rys. 2.
Most na Sprewie
1/30 n.w.

Zeitsch. f. Bauwesen
84 146. 8.

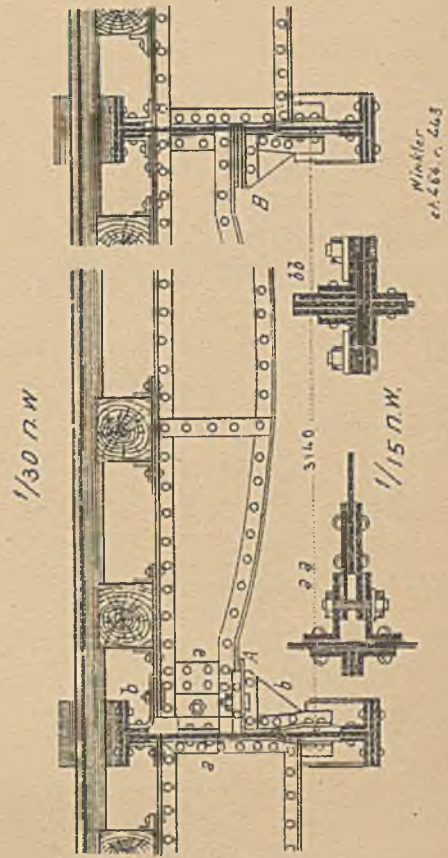

Müller
et. 400. n. 403

Albinus

MOST TRESKOW W OBERSCHÖNEWEIDE OBOK BERLINA

Rys. 1a, b. Przekrój podłużny i rzut poziomy.

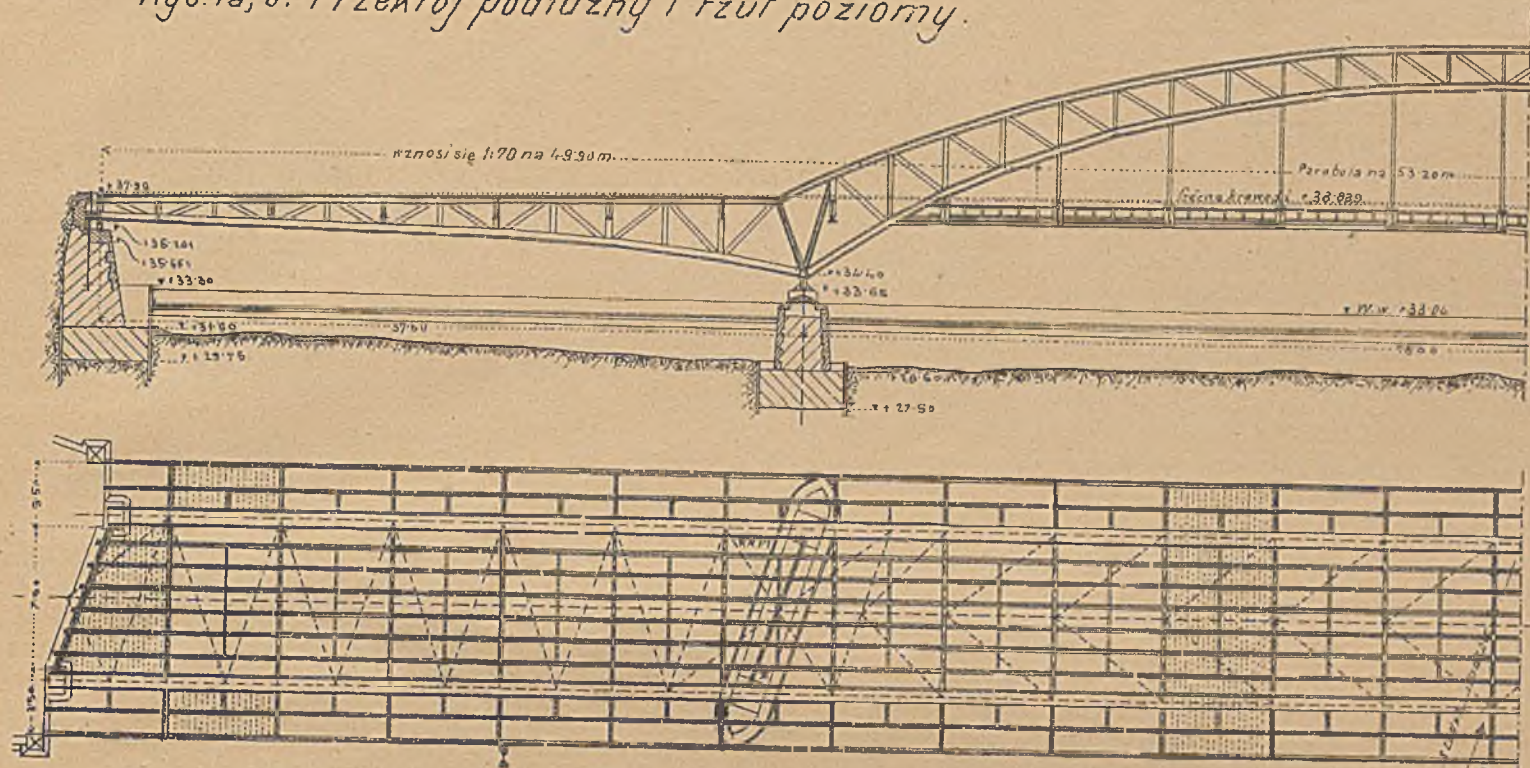

Zeitsch. d. Ver. deut. Ing. 1905 tom. 49. str. 114.

Rys. 2.

Łożysko na lewym przyczółku - przekrój przez chodnik.

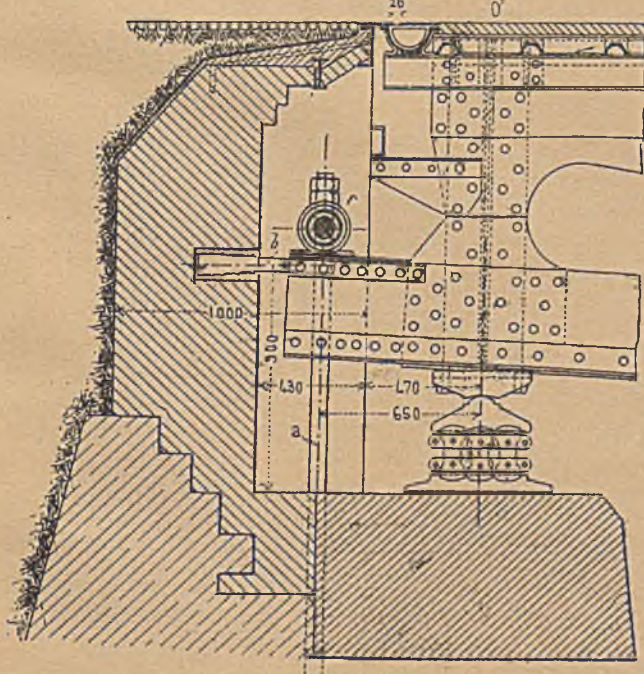

Rys. 3.

Zakończenie pomostu drogi i łożysko dla tężników poziomych - przekrój przez drogę.

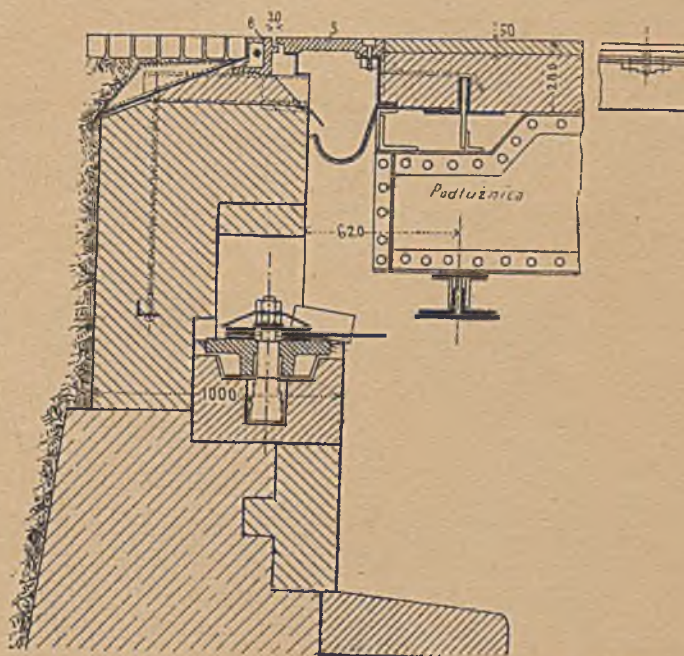

Zeitsch. d. Ver. deut. Ing. 1905 tom. 49. str. 1249.

ŁOŻYSKA I TĘŻNIKI.

Rys. 1, 2. Most „Treskow” w Oberschöneweide koło Berlina.

Rys. 1. Przekrój przez zakotwienie. [Petra tab. 190, rys. 2]

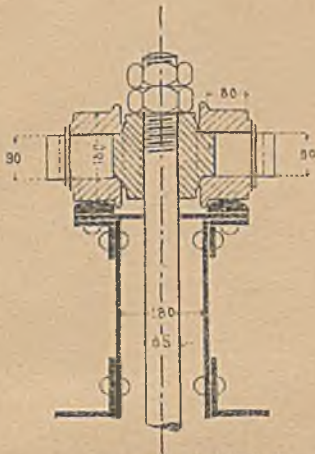

Zeits. d. Ver. d. Ing. 1905, st. 1247.

Rys. 2. Łożysko ruchome na lewym filarze.

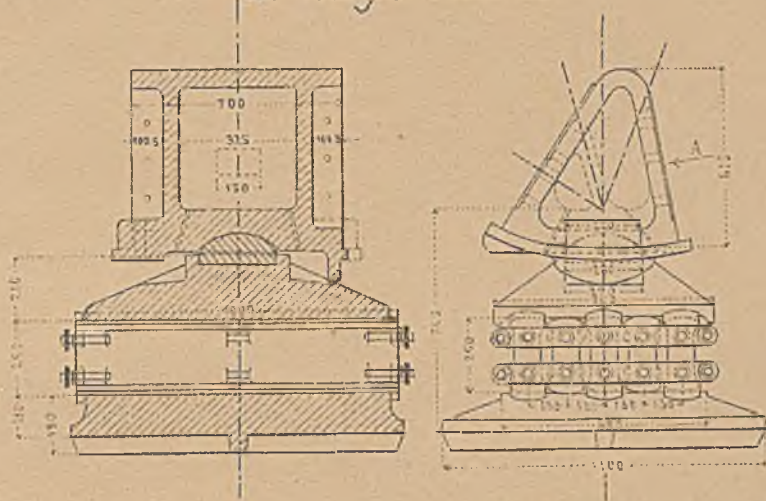

Deuts. Bauzeit. 1905, st. 177.

Rys. 3a.

Połączenie tężników poziomych na przegubie przy moście na Renie między Ruhrort a Homberg.

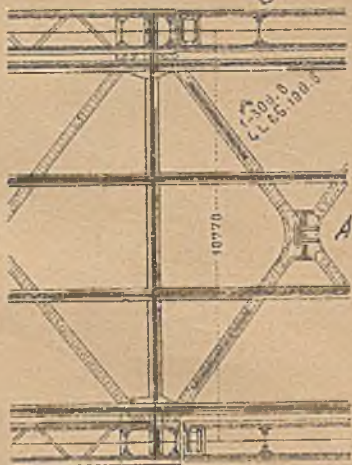

Rys. 3b. Szczegół A.

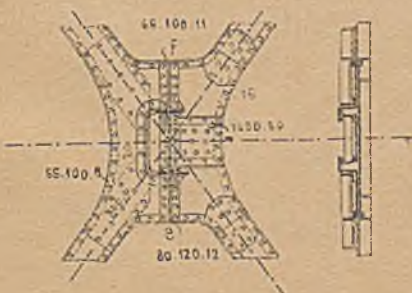

Zeits. d. Ver. d. Ing. 1905, st. 245

Rys. 4.

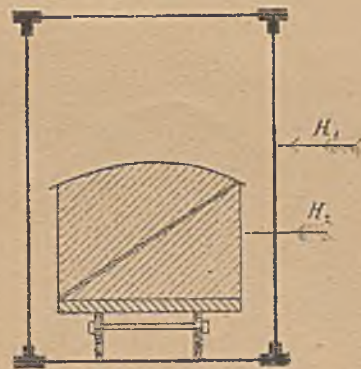

Rys. 5.

Tężniki poprzeczne przy moście w porcie Sydney [Australia].

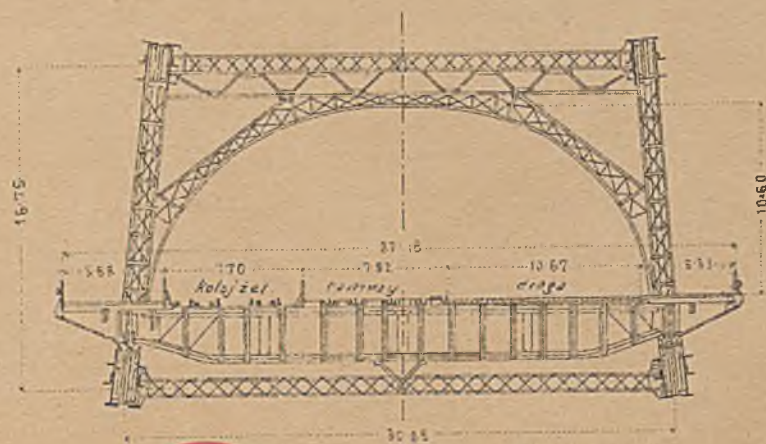

Le Génie Civil, tom. 48, st. 171



Włocławek

BG Politechniki Śląskiej w Gliwicach
nr inw.: 11 - 11432



Dyr.1 10924/2