

EDITORIAL STAFF

E. L. SHANER
Editor-in-Chief
IRWIN H. SUCH
Editor

WM. M. ROONEY
News and Markets Editor

D. B. WILKIN
Engineering Editor

J. D. KNOX
Steel Plant Editor

GUY HUBBARD
Machine Tool Editor

DON S. CADOT
Art Editor

ALLEN C. GRAY
Consulting Editor

ASSOCIATE EDITORS

G. H. MANLOVE • W. J. CAMPBELL
JAY DEEULIS • F. R. BRIGGS
VANCE BELL

ASSISTANT EDITORS

JOHN PARINA JR. • H. C. TUTTLE
HENRY J. HOLTZ • DOLORES K. BLAHA
WALTER F. TOERGE • RICHARD D. CONLY

RESIDENT EDITORS

E. C. KREUTZBERG
Washington Editor
L. M. LAMM
Associate Editor, Washington

B. K. PRICE
Eastern Editor, New York

L. E. BROWNE
Associate Editor, New York

E. F. ROSS
Chicago Editor

J. C. SULLIVAN
Pittsburgh Editor

A. H. ALLEN
Detroit Editor

VINCENT DELPORT
European Editor, London

EDITORIAL CORRESPONDENTS

R. W. KINGEY, Birmingham

L. C. FELDMANN, Buffalo

SAMUEL S. CARR, Cincinnati

MAC HUTCHENS, St. Louis

GEORGE R. REISS, Youngstown

MAURICE BEAM, Los Angeles

ROBERT BOTTORFF, San Francisco

R. C. HILL, Seattle

C. K. CATES, Dallas

F. S. TOBIN, Toronto

J. A. HORTON, Birmingham, Eng.

MAIN OFFICE

Penton Building, Cleveland 13, Ohio

BRANCH OFFICES

New York 17.....16 East 43rd St.
Chicago 11.....520 North Michigan Ave.
Pittsburgh 19.....2800 Koppers Bldg.
Detroit 2.....8560 Cass Ave.
Washington 4.....956 National Press Bldg.
Los Angeles 4.....130 N. New Hampshire Ave.
London.....2 Caxton St., Westminster, S.W. 1

Published by THE PENTON PUBLISHING CO.,
Penton Bldg., Cleveland 13, Ohio, E. L. SHANER,
President and Treasurer; G. O. HAYS, Vice
President and General Manager; R. C. JAENKE,
Vice President; F. G. STEINBACH, Vice Presi-
dent and Secretary; E. L. WERNER, Assistant
Treasurer.

Member, Audit Bureau of Circulations; Asso-
ciated Business Papers Inc., and National Pub-
lishers' Association.

Published every Monday. Subscription in the
United States and possessions, Canada, Mexico,
Cuba, Central and South America, one year \$6;
two years \$10; all other countries, one year
\$12. Single copies (current issues) 25c. En-
tered as second class matter at the postoffice
at Cleveland, under the Act of March 3, 1879.
Copyright 1946 by the Penton Publishing Co.

Business Staff on Page 4

STEEL

The Magazine of Metalworking and Metalproducing

VOL. 119, NO. 8

AUGUST 19, 1946

NEWS

Toy Industry Back on Peacetime Basis	67
Steelman Cites Output Increase Since V-J Day	69
Foundry Shutdowns Looming	70
Effect of Freight Rate Rise on Warehouse Steel Prices Clarified	72
Surplus Machine Tools Moving Slowly from WAA Warehouses	73
Changes Urged in Wagner Act, NLRB Procedures	74
Maritime Union Calls Strike Against Great Lakes Shipping	74
Canada's Metalworking Plants Receiving Only 25% of Steel Needs	75
French Wages To Be Increased 17%; Income Tax Exemptions To Be Raised	79
Technical Aid Agency Set Up in Department of Commerce	80
Launch Efforts To Obtain Lower East-Bound Rail Rates	86
Steel Supplies Easier; Labor Picture Clearing on West Coast	86
Dry Dock, with 6000-Ton Lifting Capacity, Launched on Inland River	87
International Detrola Corp. Buys Andrews Steel Co.	88

TECHNICAL

Properties of Lime Ferritic Electrodes	96
Heat Treatment and Metallurgy of Aluminum Alloys	98
Method Used To Reclaim Brass Scrap at Rate of 42,000 lb. Per Day	100
Brazing Tool Tips by Induction Heating Reduces Job Cost Per Hour	101
Efficient Large Volume Job Plating	102
Engineering News at a Glance	110
Effect of Undissolved Carbides on Hardenability	112
Use of High Strength Steels Gives Railroads Lighter Freight Cars	117
Second Operation Lathe for Precision Machining	120
How a Milling Fixture Eliminates Tool Changes	122
Selection of Die Steels for Cold Working Metals	124
Pipemaker Starts Large Improvement Program	132

FEATURES

As the Editor Views the News ..	63	Men of Industry	90
Present, Past and Pending	69	Obituaries	95
Windows of Washington	76	Industrial Equipment	136
Mirrors of Motordom	83	The Business Trend	164
Activities	88	Construction and Enterprise	186

MARKETS

High Steel Production Rate Threatened by Shortages	167
Market Prices and Composites	168

Index to advertisers

NEXT WEEK...

Hardenability Testing in Material Control
Handling Bar Stock with Mechanized Equipment
Advantages of Stamped Machine Parts
Applications of Lime Ferritic Electrodes
Metallurgy Involved in Heat Treating Aluminum



You'll be ahead with

MORGAN WORCESTER

Your competitive ability of tomorrow depends upon your decisions *today*. Will you be able to offer new products, better products at favorable prices?

Morgan-Worcester stands ready with rolling mill designs and equipment far in advance of much in current use. Why not put your problem up to us? Let us prove that "You'll be ahead with Morgan-Worcester."

MORGAN CONSTRUCTION CO.

WORCESTER, MASSACHUSETTS

Rolling Mills - Wire Machines

Gas Producer Machines - Regenerative Furnace Control

English Representative: International Construction Co.

56 Kingsway, London, W.C. 2, England

Illustrated: New type Morgan Roughing Stands. Features include (1) Improved overhead roll suspension, (2) Fully protected gear type universal spindles, (3) Improved spindle carriers.

RM-6

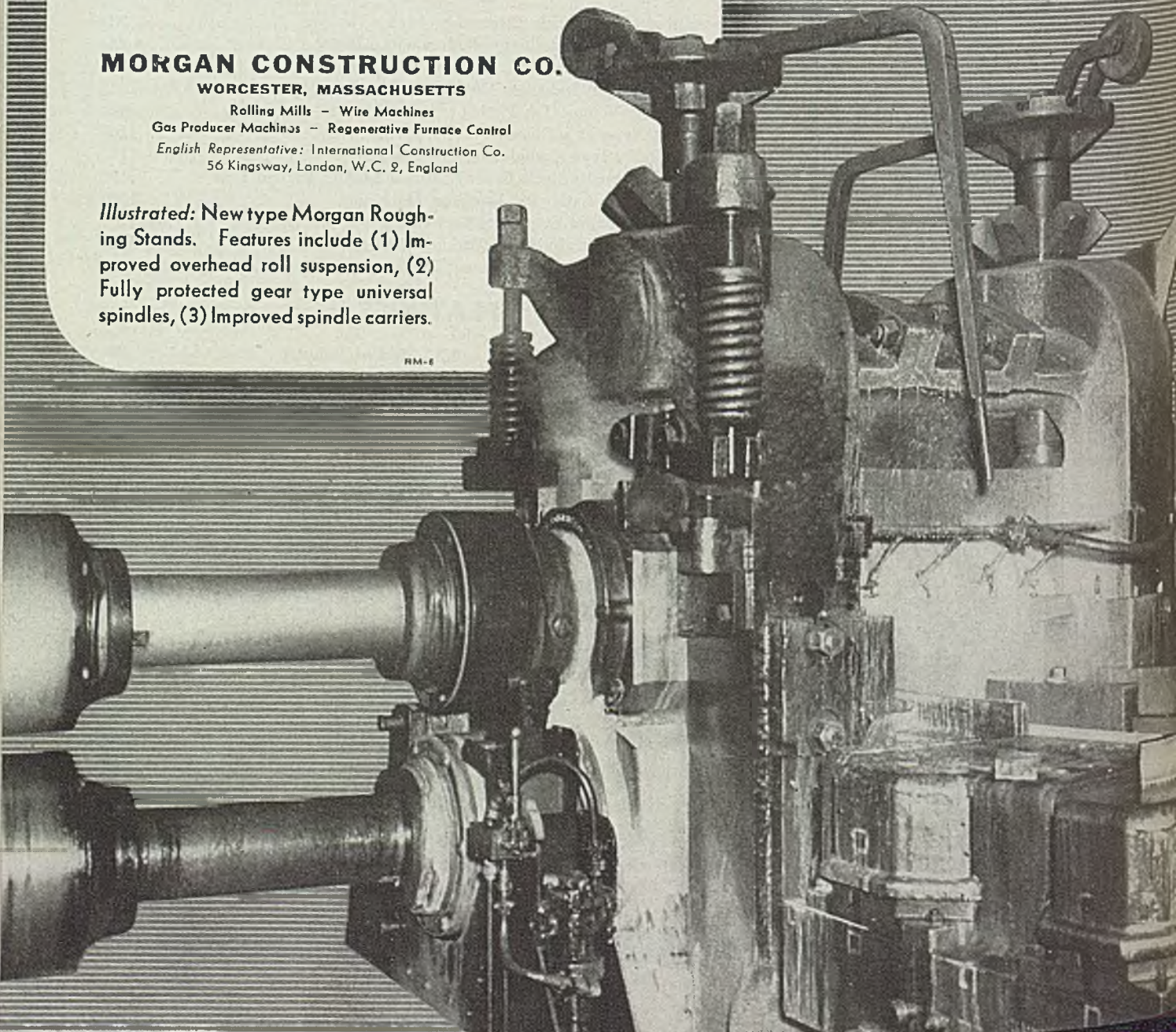

Screwy Land of Plenty

IEWS

the NEWS

Recently an editor of *Business Week* interviewed a British visitor who had completed a four-months tour of the United States. "What is the principal impression of our country you are carrying back to England?" he was asked. His reply came promptly: "It remains the only place on earth where everything can be completely screwy and almost everyone can still get along quite well."

There is a large measure of truth in this observation. It is difficult to think of any other area on the globe where the potential for abundance is so great that the people can enjoy a reasonable degree of comfortable living at the same time their government is pursuing economic policies that for the most part are unsound and ridiculous. In most countries, mistakes of the magnitude of those made by persons in high places in Washington since V-J Day would have been disastrous.

A hint of some of these mistakes is found in the Victory Day statement of Reconversion Director John Steelman. He reported that the annual production rate of goods and services for civilians has jumped \$30 billion since V-J Day, that income payments to individuals now equal or exceed the war peak of \$163 billion, that civilian employment has reached a new high of 58,100,000 and that "the proportion of unemployment is probably the lowest for any peacetime year since we became an industrial nation." As an offset to the rosy implications of these statements, Mr. Steelman warned that the threat of inflation still casts a shadow over the future.

Everything that Mr. Steelman reported conforms closely to the predictions made almost a year ago by many industrial leaders. The conditions he reported were anticipated accurately in studies made by Paul Hoffman's Committee for Economic Development. They were forecast accurately by the 3600 industrialists who replied to STEEL'S questionnaire on reconversion last fall. Industry gaged the nation's economic potential correctly.

In sharp contrast, everything Mr. Steelman reported is contradictory to what the highest government officials predicted a year ago. They estimated unemployment as high as 10,000,000 jobs. They forecast deflation and directed government policy toward fighting that menace. They even promoted a law that has the effect of shaping broad government policy according to the predictions of government economists. Had that law become effective promptly, the nation now would be fighting deflation instead of inflation.

Our luck in absorbing colossal government blunders cannot last. We need leadership in Washington that can view economic problems realistically.

STEEL

August 19, 1946

LIGHTER FREIGHT CARS: Several hundred thousand freight cars will be built for Class I railroads during the next few years. It will be interesting to note how many of them will be constructed of high strength steels.

In the case of one railroad, the ratio of dead weight of freight cars to load increased 13 per cent from 1920 to 1935. In 1935 this road began installing light weight cars of high strength steel. By 1940 the influence of these new cars had reduced the road's ratio of dead weight to load to 19.6 per cent below 1935 figure and 9.2 per cent below the

1920 level. What this experience means can be judged by the fact that the ratio of dead weight to load for all Class I roads increased 35.1 per cent from 1920 to 1935. Had all Class I roads followed the example of the railroad mentioned above, the freight car equipment that was so hard pressed to meet the nation's wartime transportation demands would have exceeded its praiseworthy record by a handsome margin.

American railroads, in sharp contrast with those in most other countries, are pre-eminently freight carriers. They can profit tremendously from the

weight-saving characteristics of these high strength steels. Properly employed, these steels can revolutionize the world's greatest rail freight system in the next five years. —p. 117

. . .

DECENTRALIZED BUYING: Ford Motor Co. is instituting a significant change in purchasing policy. It has adopted a plan to decentralize a part of its \$600 million a year purchasing operations so as to make possible a \$10 million increase annually in "at home" buying in branch assembly plants. Under its provisions, purchasing agents in 13 widely distributed Ford assembly plants are authorized to buy directly in their local communities certain items for maintenance, repairs and general stores.

This idea is well worth the attention of large corporations which have widely scattered branch plants. There are many standard supplies which, all cost and quality factors considered, can be purchased locally as advantageously as through central purchasing channels. In addition, there is the factor of increased good will in the local community which, under present conditions of doubt and misunderstanding, is an asset of incalculable value.

—p. 84

. . .

TOUGH ON EVERYBODY: Anyone who has been in Washington recently has noted the consternation in government offices caused by attempts of the administration to trim back personnel to peacetime dimensions. Retrenchment, tough on the job-holders, is music to the ears of taxpayers.

However, such curtailment as may result from the present wave of belated economy will be only a drop in the bucket. Many of the sharp cutbacks in personnel will be in the wrong places. Because of the fantastic ideas of incumbents, some bureaus that should be retained will be cut and others which should be abandoned will be continued or expanded.

The State Department, which has a man-sized job in global diplomacy, has a meager increase in appropriations in the new budget. Commerce, Labor, Agriculture and other old line departments have sharply increased budgets, based largely on the idea that the American public must be spoon-fed on pearls of wisdom from these agencies. The axe should fall heaviest upon departments that persist in perpetuating unwanted and unneeded activities. —p. 76

SIGNS OF THE TIMES: General Motors will build a large new gray iron foundry to supply short-run castings requirements of various GM divisions which have been unable to locate outside sources for such parts. Two sites in Ohio have been selected tentatively for the new foundry (p. 84), but the final decision as to where it will be built will hinge upon the currently important question of adequate labor supply. . . . Purchase of a manufacturing or fabricating plant by a steel producing company is commonplace news, but the reverse—wherein the former acquires the latter—is unusual. International Detrola Corp., Detroit, manufacturer of radios, refrigerators, air conditioning equipment, cedar chests and furniture (p. 88), has purchased all of the steelmaking, rolling mill, fabricating facilities and coal mining interests of the Andrews Steel Co., Newport, Ky. . . . France is entering upon a risky experiment in planning. A committee of the National Economic Council recommended that the demands of labor unions for a 25 per cent increase in wages be met by granting an increase of 21 per cent. The government, after considering this recommendation (p. 79), decided to raise wages 17 per cent and to raise income tax exemptions and family allowances to offset the smaller increase in wages. Private enterprise will not be allowed to increase prices. If employers cannot meet the new wage burdens, they may be given government subsidies. Nationalized business, such as railroads and electric power, will be granted sharp increases in the prices for their services. There will be headaches for everybody. . . . Adopting induction heating for brazing tungsten carbide tips to more than 200 types of cutting tools resulted in such substantial economies that an independent tool producer in the Detroit area (p. 101) was able to amortize the cost of his two induction heating machines in three months. . . . Program of the Office of Technical Services of the Department of Commerce sounds elaborate and to some extent unnecessary (p. 80), even though department spokesmen go to great lengths to emphasize the fact the new services will not compete with those of private industry. . . . Purchasing officials of Studebaker compiled a "Chronology of Despair," citing strikes and other obstacles (p. 83) to explain why the company had been able to build only 43,011 cars and trucks in the nine months ending June 30 instead of the 134,500 scheduled for that period.

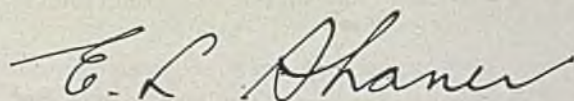

EDITOR-IN-CHIEF



Resources

The vast resources of the Inland Steel Company are important factors to volume users of steel.

Extensive mines and quarries...modern freighters...towering blast furnaces...the glowing open hearths and coke ovens...the powerful rolling mills, vibrant with action and life!

Activating these resources and modern

facilities are Inland's experienced engineers and metallurgists applying their skills to every phase of development, production, and control...making certain that every ton of steel produced is worthy of the name...INLAND!

Yes, Inland has the resources to produce quality steel for you.

HELP! MORE SCRAP NEEDED!

Extra tons of scrap are needed to make the extra tons of steel for American industry. Please keep your scrap moving back to the mills.



● Inland Steel Company, 38 South Dearborn Street, Chicago 3, Illinois. Sales Offices: Detroit, Indianapolis, Kansas City, Milwaukee, New York, St. Paul, St. Louis.

PRINCIPAL PRODUCTS: Bars • Structurals • Plates • Sheets • Strip • Tin Plate • Floor Plate • Piling • Reinforcing Bars • Rails • Track Accessories

August 19, 1946

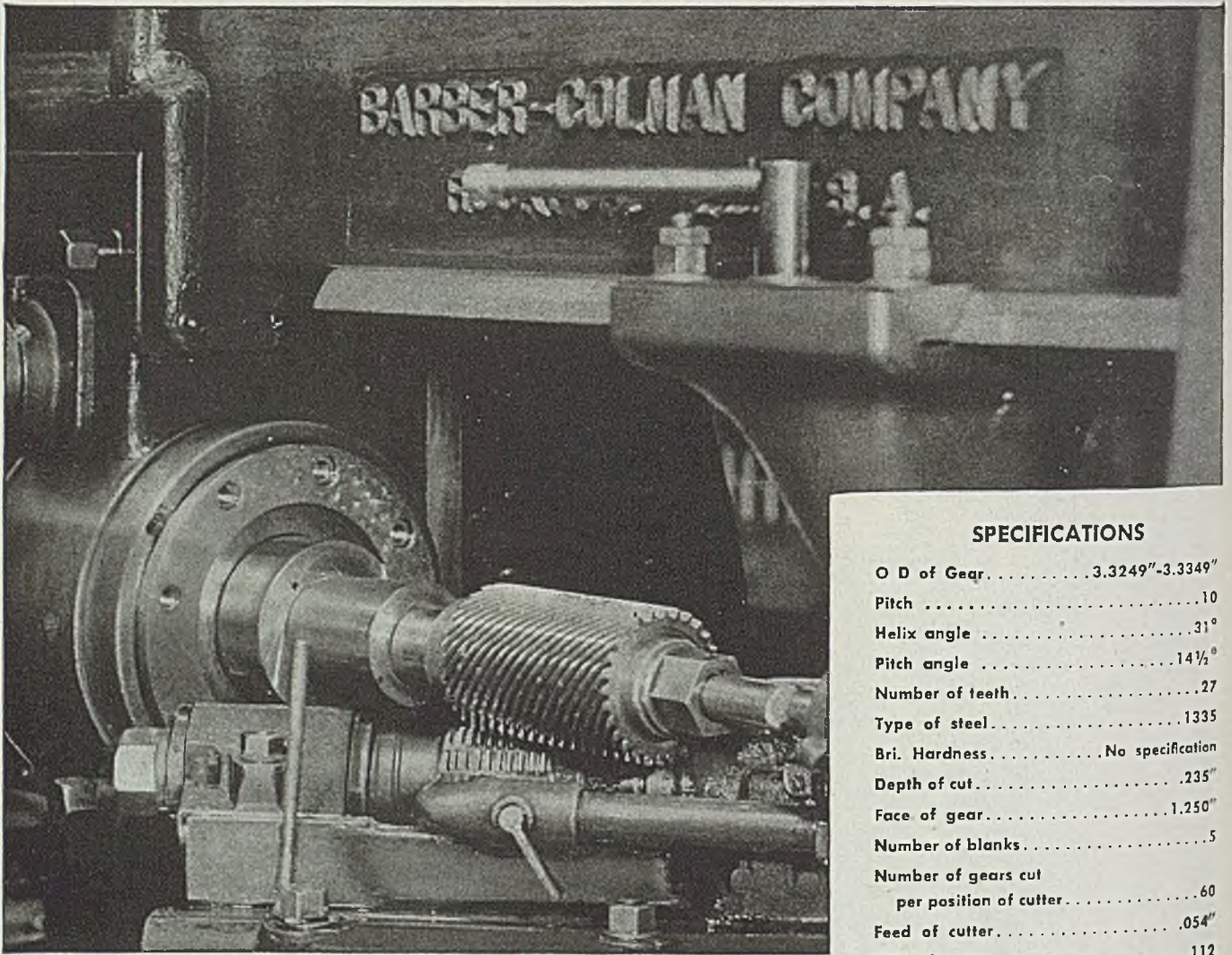

SPECIFICATIONS

O D of Gear	3.3249"-3.3349"
Pitch	10
Helix angle	31°
Pitch angle	14½°
Number of teeth	27
Type of steel	1335
Bri. Hardness	No specification
Depth of cut	.235"
Face of gear	1.250"
Number of blanks	5
Number of gears cut per position of cutter	60
Feed of cutter	.054"
RPM of cutter	112
RPM of work	6
Machine	Barber-Colman Hobber Type A

100% Longer Hob Life ➡

Amount of metal removed in sharpening
CUTTER using Texaco is only .012"-.015"
Amount of metal necessary to remove in
sharpening CUTTER using previous oil .025"-.030"

IN CUTTING gears to the specifications listed above, the operator reported *50% less metal had to be removed from the hob in regrinding — 100% longer hob life* — after he had switched to Texaco! This performance is typical of the greatly improved results you get — in all types of metal cutting — with *Texaco Cutting and Soluble Oils*.

Texaco Cutting and Soluble Oils effectively lubricate and cool tools, prevent chip welding, permit higher cutting speeds, give you more cuts

per tool grind and longer tool life. There is a complete line of these outstanding oils to meet every machining requirement — to assure greater output, finer finish, fewer rejects, lower costs.

For Texaco Products and Lubrication Engineering Service, call the nearest of the more than 2300 Texaco distributing plants in the 48 States, or write:

The Texas Company, 135 East 42nd Street,
New York 17, N. Y.



TEXACO CUTTING, SOLUBLE AND HYDRAULIC OILS FOR FASTER MACHINING

TUNE IN THE TEXACO STAR THEATRE EVERY SUNDAY NIGHT — CBS

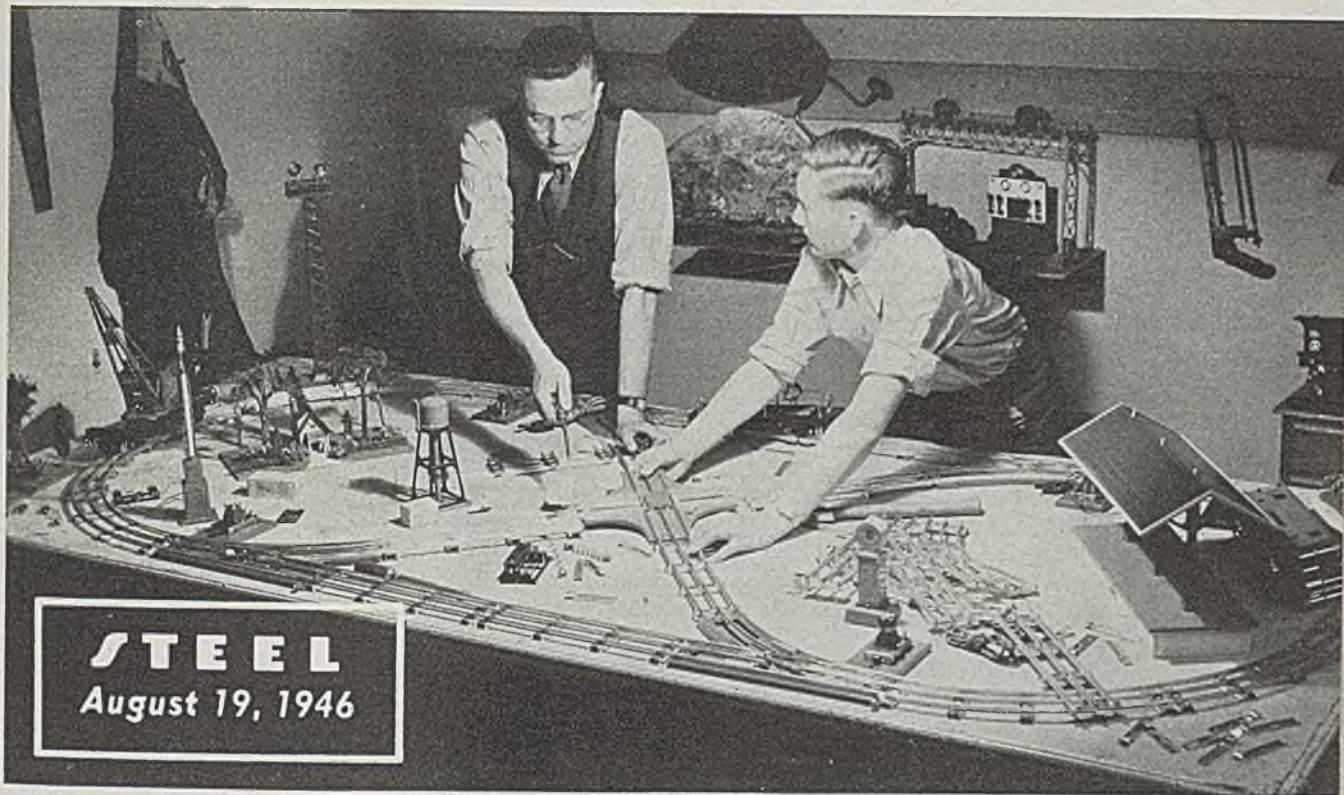

Many a father and son team have been awaiting the reappearance of electric trains and equipment, manufacture of which was practically nil during the war. Manufacturers believe a large accumulated demand for such toys exists.

Photo, courtesy, Lionel Corp.

Toy Industry Back on Peacetime Basis

METAL toy manufacturers, prewar consumers of 110,000 tons of steel annually, important users of nonferrous metals and buyers of ball bearings, screw machine products and light metalworking machinery, are well on their way back from the war.

Reconversion problems, not too complicated, are long since resolved, and with the lifting of various wartime restrictions on the use of metals for toy manufacture, the industry has stepped up its consumption sharply from virtually nothing during the emergency.

As steel and other metal supplies become more plentiful the industry expects not only to get back to its annual prewar consumption of 110,000 tons of steel, but to exceed it. This, toy manufacturers are confident, will come just as soon as steel mills are able to produce at a sustained high rate for a while.

At present there are approximately 2000 toy manufacturing companies, employing approximately 35,000 persons. Back in the NRA days, in the middle 30s, fewer than 500 companies of sufficient size to rate attention by the National Recovery Administration, were engaged in toy manufacture. Just before the war

Manufacturers expect to exceed prewar consumption of 110,000 tons of steel annually as soon as supplies become more plentiful. Industry's 1941 retail sales volume totaled \$240 million. Includes 2000 companies employing 35,000 workers

the number of established concerns had been increased to between 900 and 1000. During the war the Office of Price Administration was called upon for price information by more than 3000 different interests. However, a number of these obviously represented small establishments and in many instances were individuals engaged in the making of toys in their own homes.

Many of these have disappeared since, so that a figure of 2000 manufacturers appears to be reasonably accurate, and this number is expected to decline somewhat as time goes on.

About 87 per cent of the toys produced in this country are manufactured in eight states, listed in the order of their im-

portance: New York, Massachusetts, New Jersey, Illinois, Pennsylvania, Michigan, Connecticut and Ohio. This order of states was true according to the 1939 census and is regarded as true today. Some states have stepped up in their importance to toy manufacture, such as California, Wisconsin, Minnesota, Indiana and Missouri. But none of these has stepped ahead of any in the first mentioned group, trade authorities declare.

The United States toy industry in 1941, just prior to the war, produced \$240 million of toys on a retail sales basis and \$120 million or just half the foregoing, on a manufacturers sales basis. Interestingly, while manufacturers of metal toys and various other types also shifted into war work in one degree or another, the volume of toys in point of sales value during the war period was quite heavy. This may be accounted for in part by somewhat higher prices and by the step-

By B. K. PRICE
Eastern Editor, STEEL

ping up of production of many items which would be made of materials not primarily essential to the war effort.

What the sales value will be this year cannot be estimated accurately, but with production heavier and with costs going up and prices being advanced accordingly, it may equal or even exceed 1941. Some of the more conservative estimate a total manufacturers' sales value of possibly \$125 million, up \$5 million from prewar.

Many of the newer companies, they say, represent small establishments, with a certain percentage steadily disappearing from the scene, and various others have not yet gotten back to full prewar employment. In fact, total employment in the industry at present is estimated at being only a few thousand or so more than in 1941. However, the general

upward trend in production should continue as raw materials increase.

Last March at the annual toy exposition, which usually is held every year at that time in New York, more than 8000 buyers attended. This exceeded any previous attendance by more than 3000, and commitments were heavy.

Of the total valuation of toys produced in 1941, just before the war, metal toys other than mechanical toys represented 14.5 per cent; trains and track equipment, 5.9 per cent; mechanical toys other than trains, 9 per cent; and wheel goods and sleds, 15.2 per cent, or a total of 44.6 per cent. While the remainder requires some metal, the great bulk of steel and other metals consumed go into the above listed classifications.

A breakdown of the remaining 55.4 per cent, interestingly, is as follows: Dolls,

15 per cent; stuffed toys, 4.9 per cent; wooden toys, 6 per cent; rubber toys, 5.9 per cent; games, 11.4 per cent; and miscellaneous 12.2 per cent.

Of the 110,000 tons of steel consumed in the manufacture of toys in 1941, between 45,000 and 50,000 tons went into wheel goods, such as wagons, velocipedes and similar items. It is said with respect to wheel goods that the ratio of the use of steel to the sales value ran as high as 1000 tons to \$600,000 in manufacturers' sales. The ratio for metal toys as a whole ran 1000 tons of steel to \$400,000 in manufacturers' sales value.

Steel requirements include sheets, strip, wire, tin plate, cold drawn bars, nuts, bolts, screws and a variety of other items. Specifications for sheets usually include pickled, cold-rolled and annealed grades, ranging from 16 to 28 gage. Much end scrap, arising from shearing operation in automobile plants and stamping factories, normally finds its way into the manufacture of toys. At the same time, as in the case of toy automobiles, for body requirements, a high grade full finished auto body stock is used, usually around 22 gage.

Considerable seamless tubing is used in the manufacture of velocipedes, scooters, express wagons and various other items. Wire for wheel spokes, usually 11 or 12 gage, runs into quite a considerable tonnage. In addition to numerous rolled steel products, there are die castings and small sand castings, all aggregating a fair tonnage, to say nothing of nonferrous requirements.

Produced \$500 Million of War Goods

During the war manufacturers of metal toys diverted production to emergency needs. For instance, 53 toy manufacturers alone turned out more than \$266 million in direct war materials, not including approximately \$1 million of recreational items, such as required by the Red Cross and other wartime agencies. It was authoritatively estimated that production of war materials by the industry as a whole ran well in excess of \$500 million with a number of companies receiving E awards in recognition of their services.

However, with all reconversion problems over, the industry is now back on a full peacetime basis, ready to further step up its operations over the next several months just as rapidly as steel and other raw materials become available.

In addition to domestic demands there are substantial inquiries from abroad. Last year, 1945, exports of toys from this country amounted to \$2.8 million. This year shipments are expected to run heavier. Interesting from a comparison standpoint is the export total of \$3.5 million in 1941.



Scene in assembly division of electric toy train manufacturing plant

Steelman Cites Output Increase Since V-J Day

Reconversion director reports almost full employment attained with production of civilian goods up \$30 billion

WARNING that the threat of inflation still "casts a shadow over the future," Reconversion Director John Steelman, last week in a Victory Day statement, reported the nation had achieved substantially full employment and record profits in the year since the Japanese surrender.

Yearly production rate of goods and services for civilians has jumped more than \$30 billion since V-J Day, he reported, while total construction has increased almost four times. Nearly 250,000 new businesses were established in the last half of 1945.

Profits of heavy industry sagged sharply during the year because of the loss of war contracts and high reconversion costs, Director Steelman said, but in the rest of the economy he declared profits after taxes were at the highest levels on record.

Income payments to individuals now equal or exceed the war peak of \$163 billion, being more than 60 per cent over the peacetime peak of \$100 billion in the last quarter of 1941, he said. In attaining full employment nearly 5 million new jobs have been added, bringing civilian employment to 58,100,000 compared with 51,200,000 in the period immediately following V-J Day.

"The proportion of unemployment is probably the lowest for any peacetime year since we became an industrial nation," said the reconversion director, adding that no significant increase in joblessness is expected over the remainder of the year with labor shortages beginning to appear in some areas and in some industries. Fewer than 1 million demobilized veterans are still looking for jobs, he said.

Citing that during the last 60 days there have been no new strikes in key industries, Steelman said, "if we can continue this fine record for the next few months, we shall be well on the way toward full peacetime production."

Tin Plate Export Quotas Upped for Fourth Quarter

Fourth quarter allocations of tin plate for export have been fixed by the Civilian

Production Administration at 136,000 tons, an increase of 24,000 tons over third quarter quota.

Increases were granted largely to areas below the equator, notably Australia, New Zealand, South Africa and South America, where heaviest food pack comes in the fourth quarter and the first quarter of next year. Of the total allocation, these four areas will receive 94,250 tons.

The exported tin plate will be used entirely for preservation of food in or for famine-stricken countries and will take some of the pressure off domestic food production.

Members of the Tin Plate Industry Advisory Committee expressed unanimous agreement at a recent meeting that the tin mill products order channeling 85 per cent of these materials into the making of cans and closures for perishable foods, pharmaceuticals and other so-called "A" cans should not be continued in its present form. Members did not agree, however, as to whether the order (direction 9 to M-21) should be revoked Sept. 30, or retained in modified form for the fourth quarter. This direction was issued Feb. 7 to safeguard the perishable food

pack threatened by loss of production of tin mill products due to the steel strike.

Charles Halcomb, government presiding officer at the meeting, said that supply conditions, which necessitated the issuance of the direction in February, are not expected to continue through fourth quarter and, therefore, the restrictive channeling of tin mill products into perishable food can production in that quarter may not be required. He also said that seasonal requirements for food cans themselves will be diminishing after September.

In addition, Mr. Halcomb pointed out hundreds of industries have undergone severe hardships in attempting to maintain production on their slim share of the 15 per cent output of tin mill products which is available to them under direction 9.

Included in fourth quarter requirements for certified orders is a carryover of 80,000 tons for food cans and the foreign relief program. Some of this carryover is not due to lack of production in third quarter, manufacturers said, but to inability to obtain packaging materials for delivery within the quarter.

Present, Past and Pending

■ GENERAL MOTORS DOMESTIC OUTPUT CONTINUES TO RISE

DETROIT—For the third consecutive week, General Motors domestic output continued to rise, amounting to 21,113 passenger cars and 7464 trucks for week ended Aug. 10. Supplier strikes now total 72 of which 57 are in this country. Total GM production from Jan. 1 to Aug. 10 was 422,076 vehicles compared with 1,731,076 in the like period of 1941.

■ FORGINGS PRICE SCHEDULE REVISED BY OPA

WASHINGTON—Forgings producers undertaking production in newly constructed plants have been placed under the same pricing provisions as forgers producing the same commodities on the base date under price regulation 351, which originally exempted new plant production from using the Oct. 1, 1941, base.

■ STEEL INDUSTRY CUTS ITS ACCIDENT FREQUENCY RATE

NEW YORK—Steel industry reduced its frequency rate of accidents 0.77 points last year to 7.23 per million manhours of work, moving from fifth to fourth place among safe industries as listed by National Safety Council. Frequency average for all industries reporting in 1945 was 13.63 accidents per million hours of work.

■ KAISER MAY BID FOR EAST CHICAGO STEEL PLANT

CHICAGO—Henry J. Kaiser may submit a bid for the blast furnace and coker oven plant built by the government in East Chicago, Ind., and now being offered for sale or lease by WAA. Inland Steel Co., wartime operator and present lessee of the facilities, also will submit a bid.

■ OFFERS TO TRADE FINISHED PRODUCTS FOR SHEET STEEL

CHICAGO—Lyon Metal Products Inc., Aurora, Ill., is offering to barter finished steel products for sheet metal. Any Lyon product in current production or any product made to a customer's own specifications, if ordered in production-run quantities, will be exchanged on a pound-for-pound basis for the steel furnished.

■ VETERANS FORCE ONE-DAY CLOSING OF 3 AUTO PLANTS

PONTIAC, MICH.—A group of 200 war veterans paraded in front of three General Motors plants here last Wednesday carrying signs demanding vacation pay allowances, even though they had been employed less than one year. The plants were closed for the day since 13,000 workers refused to walk through the parade to their jobs.

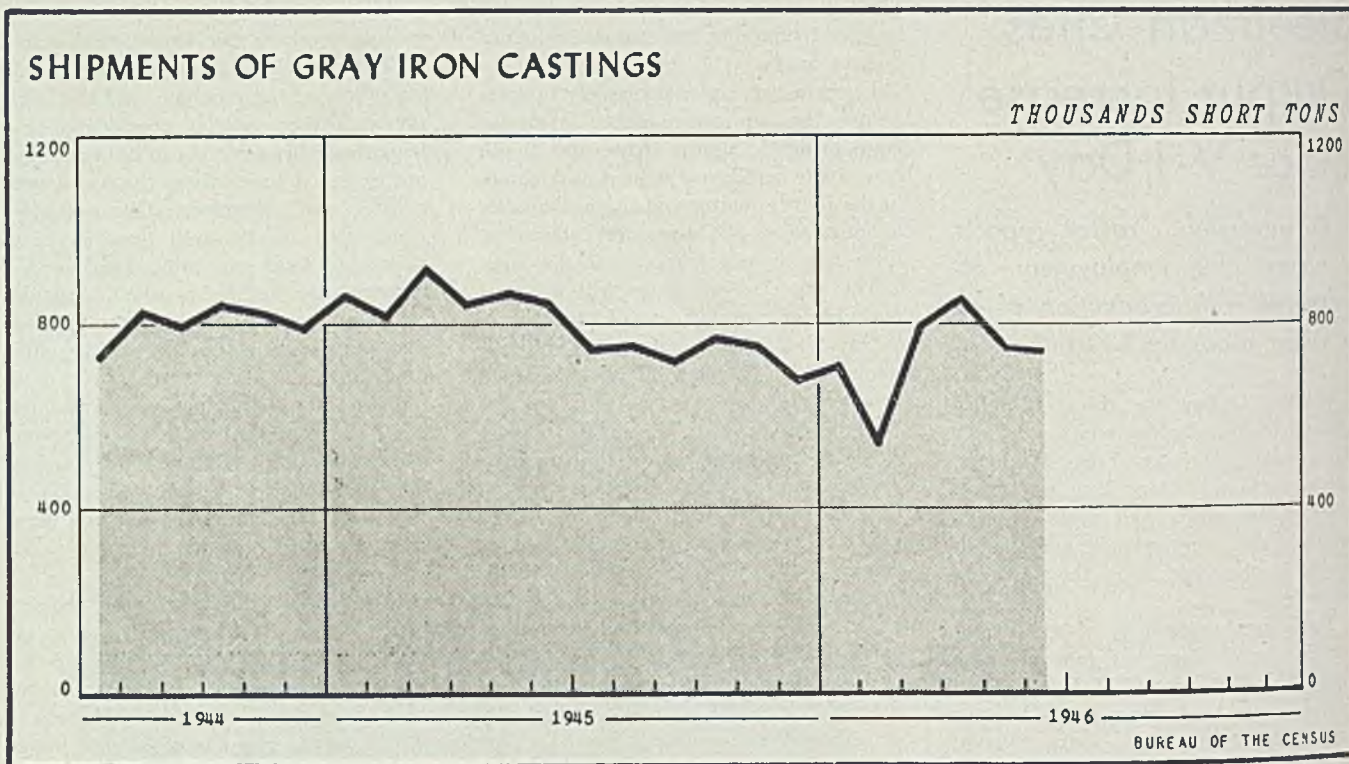

Foundry Shutdowns Looming

Acute shortages of pig iron and scrap threaten severe curb on casting shop operations. Conference called to devise plan for averting serious check on production. Earmarking iron for favored reconversion industries opposed

By WILLIAM M. ROONEY
News & Market Editor, STEEL

SEVERE curtailment of foundry operations threatens because of casting shops' inability to obtain pig iron and scrap in sufficient volume to keep cupolas and electric furnaces pouring at capacity. Several large gray iron foundries currently are down and others are on curtailed schedules.

So serious has the situation become, a special meeting of the Gray Iron Foundry Industry Advisory Committee with the Civilian Production Administration has been called for Aug. 20 in Washington to discuss ways and means of alleviating the supply shortage. The meeting was called on request of Edward C. Hoenicke, general manager of the Foundry Division, Eaton Mfg. Co., Cleveland.

In a move to correct inequitable distribution of pig iron supply, the Civilian Production Administration last week ordered a revision in purchase authorizations for August. The agency has reduced authorizations to purchase merchant pig iron during August in the southern area for the production of cast

iron pressure pipe by 25 per cent, and for the production of all other products, except cast iron soil pipe, by 10 per cent. Certain furnaces located in the Pittsburgh and Buffalo areas and eastern Pennsylvania who have received disproportionate share of certified orders have been directed to reduce each such order for August delivery by 10 per cent.

Almost complete drying up of scrap supplies and the earmarking of pig iron for favored industries have resulted in curtailment of castings output, which in turn is being felt by practically every manufacturing industry. Further, Mr. Hoenicke says, unless the forthcoming meeting can find a solution to the emergency, the entire gray iron foundry industry faces severe curtailment with consequent reduction in practically all metal manufacturing.

Fighting desperately to increase production, castings producers have been losing ground lately, shipment data for June showing declines in all ferrous casting categories. Gray iron castings shipments during the month were off 3 per cent from May, totaling 735,000 short tons. Of the total, 436,000 tons were castings for sale, down 4 per cent.

Malleable castings shipments amounted to 61,650 short tons, down slightly from the 62,598 tons moved in May. Shipments of steel castings also were off, amounting to 124,000 short tons, drop of 4 per cent from May and 16 per cent under the postwar peak attained in April.

Supply difficulties stem from a combination of factors common to postwar adjustment of industry generally. However, conditions have been particularly vexing and confusing for the foundries, being aggravated by the interference of government agencies with the natural flow of raw materials. Chief complaint on this score is registered against channeling of short pig iron supplies into favored reconversion programs, such as veterans housing, to the disadvantage of the regular run of castings production.

Despite recovery in pig iron production since the end of the coal strike, output is insufficient to match demands. In June, 3.39 million tons of pig iron were produced, including 373,000 tons of malleable and foundry grades. This was a substantial gain compared with May output of 2.25 million tons, but the production of foundry and malleable grades was less than half that necessary to meet estimated foundry requirements.

Currently the foundries are entertaining a tremendous volume of business and their order backlogs are growing. Unfilled orders for gray iron castings at the end of June amounted to 2.6 million tons, an increase of 6 per cent over the May total. New orders for malleable castings in the month, less cancellations, were up 11 per cent over May, totaling

43,429 tons. Unfilled orders for steel castings were off slightly from May, amounting to 361,000 tons.

The shortage of foundry scrap is particularly critical and there is little prospect of any early improvement in supply unless the newly launched salvage drive of the government is successful. Foundry industry spokesmen have been urging the government to step up return of battlefield scrap to this country and only last week were assured this was being done. Surplus shipping is being used to bring back battlefield scrap as a quick means of solving the shortage but the flow is pitifully small while the bureaucrats look on the project with a fishy eye, pointing out the difficulties entailed in collecting, sorting and shipping.

As a result of the acute scrap shortage the gray iron foundries are being forced to use larger pig iron charges in their melts. This added drag on available stockpiles without corresponding increase in blast furnace production is leading to increasing stringency in supply. If the foundries are to make any appreciable headway against the huge order accumulations for castings from manufacturing industry in general, currently idle blast furnaces must be restored to production. At the end of June there were 35 blast furnaces dependent on Lake Superior iron ore idle for one reason or another. In addition a number of stacks dependent on ore from other fields were cold. In many instances these furnaces are inactive because of inability to produce at a profit under current OPA price schedules. Government subsidizing of several of these furnaces has been suggested as an answer to the problem but so far nothing has come of the idea. It is still in the proposal stage with financing problems standing in the way of action.

Self-Certification Causes Confusion

Direction 13 to M-21, issued some time ago by the Civilian Production Administration, rubs a particularly sore spot with foundrymen. This order provides for self-certification of castings for farm machinery, brake shoes and certain items going into housing, and for the allocation of pig iron to foundries producing such castings. Generally speaking, it is viewed as a political maneuver by the Housing Administration, being forced on CPA against the latter's better judgment. The order, it is said, rather than increasing production of castings, has resulted in such confusion as to decrease output. At many points work has stopped on numerous houses in various stages of construction, not for lack of cast iron pipe but rather because of shortages of nails, lumber, etc.

One indignant foundryman says continuance of direction 13 to M-21 would result only in numerous holes in the ground throughout the country with plenty of cast iron pipe lying about for months awaiting delivery of lumber and other materials before building can be started. Meanwhile, industries in dire need of gray iron castings go without.

Some improvement in the foundry situation is anticipated at the end of September when direction 13 to M-21 expires. Last week in reviving the CC preference rating system, CPA issued, among other orders, direction 14 to M-21

which validates the carryover of self-certified castings orders placed for September delivery but stipulates that such be treated as CC orders for the month of October only.

Despite the steel industry's strenuous attempts to get more scrap, the shortage has resulted in idle open-hearth furnaces, causing a daily loss of enough steel to make 2150 automobiles or nails enough to build approximately 15,000 small homes, according to R. W. Wolcott, chairman, Committee on Iron and Steel Scrap, American Iron & Steel Institute.

SUMMARY OF PRODUCTION OF IRON AND STEEL PRODUCTS

(Net tons)

Product	1945	1944	1943	1942	1941
Pig Iron:					
Basic.....	39,866,982	45,886,008	45,374,662	43,532,865	39,759,841
Bessemer.....	8,255,513	9,756,836	10,258,788	9,865,220	9,622,343
Low phosphorus.....	514,063	474,686	538,832	562,672	474,428
Foundry.....	2,248,887	2,190,681	2,059,501	2,546,530	2,760,827
Malleable.....	2,350,076	2,494,659	2,393,241	2,399,520	2,417,137
Forge or mill.....					1,074
All other.....	187,648	204,569	185,646	169,137	184,901
Total.....	53,223,169	61,007,439	60,810,670	59,075,944	55,100,551
Ferro-Alloys:					
Ferro-manganese and spiegel...	706,078	809,638	803,629	785,103	730,009
Ferro-silicon.....	817,849	837,944	923,450	880,843	729,716
All other.....	171,933	211,177	232,204	161,414	126,328
Total.....	1,695,860	1,858,759	1,959,277	1,827,360	1,586,053
Total Pig Iron & Ferro-Alloys..	54,919,029	62,866,198	62,769,947	60,903,304	56,686,604
Steel (ingots & steel for castings):					
Open hearth—basic.....	71,069,876	79,168,294	77,207,870	75,183,065	73,312,851
" " —acid.....	869,726	1,195,659	1,413,934	1,318,892	1,076,768
Bessemer.....	4,305,318	5,039,923	5,625,492	5,553,424	5,578,071
Electric.....	3,456,704	4,237,699	4,589,070	3,974,540	2,869,266
Crucible.....	24	25	146	2,010	2,313
Total Steel.....	79,701,648	89,641,600	88,836,512	86,031,931	82,839,259
Finished Hot Rolled Products:					
Plates—universal.....	1,228,676	1,676,100	1,603,247	1,825,372	1,265,964
" —sheared.....	6,017,212	11,447,323	11,515,693	9,974,228	4,933,811
Sheets—hot rolled.....	12,067,487	10,339,080	9,403,002	9,199,273	13,602,685
Strip.....	2,542,935	2,593,107	2,125,221	1,901,153	2,540,074
Strip and sheets for cold reduced black plate and tin plate....	4,436,924	4,177,865	2,982,379	3,281,800	4,328,111
Hoops.....	51,891	68,596	60,884	93,071	108,722
Cotton ties and baling bands...	34,216	35,892	46,212	54,895	44,461
Black plate.....	941	556	21,098	238,199	490,811
Total.....	26,380,282	30,338,519	27,757,736	26,568,051	27,314,439
Bars—merchant.....	9,649,412	10,532,250	11,383,501	10,110,222	9,143,455
" —concrete reinforcement..	834,806	628,944	474,546	1,829,760	1,835,243
Total.....	10,484,218	11,161,194	11,858,047	11,939,982	10,978,698
Structural shapes—heavy.....	3,571,683	3,824,106	*3,869,736	4,944,670	4,670,782
" " —light.....	895,481	852,375	*706,108	871,651	1,053,454
Steel piling.....	189,639	128,879	36,970	152,688	209,183
Rails.....	2,417,520	2,490,656	2,126,996	2,096,159	1,927,851
Splice bars and tie plate bars...	856,638	862,383	*697,766	745,150	742,382
Skelp.....	2,891,023	3,049,682	3,022,398	2,900,741	3,637,574
Blanks or pierced billets.....	3,334,489	3,677,631	*3,356,829	3,039,174	2,945,921
Wire rods.....	4,531,157	4,646,298	4,693,798	4,632,017	5,268,423
Rolled forging billets.....	3,566,697	3,762,575	3,796,931	2,881,687	1,769,816
Blooms, billets, etc., for export.	178,600	468,088	825,966	1,194,636	1,158,519
Car wheels (rolled steel).....	291,375	291,529	233,915	234,794	269,911
All other.....	170,867	250,064	309,477	244,514	377,234
Total Hot Rolled Products....	59,811,669	65,803,979	63,292,673	62,445,914	62,324,187

* Revised. Source, American Iron & Steel Institute.

Effect of Freight Rate Rise on Warehouse Steel Prices Clarified

Freight factor from basing point to destination, when used in formula computation of delivered prices, may be raised by amount of July 1 rate increase, OPA rules. Reseller must absorb rise in actual freight rate from shipping point to destination

EXTENT to which steel warehousemen and jobbers are permitted to reflect the July 1 freight rate increase in their ceiling prices, computed under revised price schedule No. 49, was outlined recently by the Office of Price Administration.

The freight factor from governing basing point to destination, generally used in determining delivered prices, may be increased by the amount of the increase in freight rates. However, the increase in the actual freight rate from shipping point to destination must be absorbed by the reseller.

Warehousemen of merchant trade products, when computing maximum prices by use of their Apr. 16, 1941, selling prices, may use the higher freight factor from shipping point to destination; when computing prices by formula provided in the schedule, they may compute all freight factors on the basis of the higher freight rates. For direct mill shipments, resellers may compute their prices by the same method that their source of supply is permitted to use under provisions of price schedule No. 6.

Distributors of pipe and tubular products may include the higher freight rates in figuring their maximum prices only if they are permitted to use the formulas provided in RPS-49. If the seller must use his own Apr. 16, 1941, selling prices, the higher freight rates will not change his maximum prices. For direct mill shipments, the seller may use the higher freight rates in figuring the maximum delivered prices.

Tool steel jobbers may not adjust their maximum prices because of the increased freight rates. For direct mill shipments, the reseller may use the same freight factor permitted their source of supply under provisions of RPS-6.

Warehouses handling all grades of alloy structural shapes, plates, strip and sheets (except stainless and low-alloy high-tensile or low-alloy corrosion steels), if they use their Apr. 16, 1941, selling prices, may not include the higher freight rates in computing prices except in figuring the freight factor from shipping point to destination. If the seller is permitted to use the formula provided in RPS-49, the factors in the formula may reflect the increased freight rates. For direct mill

shipments, prices may reflect the increased freight rates for these grades of steel.

Resellers of new cotton bale ties may not use the increased freight rates except in figuring a freight factor from shipping point to destination. In selling used cotton bale ties, they may use the new freight rates from the applicable port to destination.

Warehousemen selling secondary or rejected grades of hot and cold-rolled sheets and strip, plates, tin mill black plate, semifinished products, and coated sheets, other than tin plate and short ternes, may use the new freight rate in every instance where freight is a factor in the formula provided under the price schedule for figuring a maximum price. In figuring maximum delivered prices for all other secondary or rejected new iron and steel products, the higher freight rates may be used only in

computing the freight factor from shipping point to destination. When computing the price of comparable prime material and the price for secondary or rejected tin plate and short ternes sheets, the seller may use the increased freight rates.

Distributors selling prime heavy line steels (carbon steel hot and cold-rolled sheets and strip, bars, plates and structurals) may use the new freight rates (Please turn to Page 182)

Steel Ingot Production Highest in 12 Months

Production of steel ingots and steel for castings during July was highest of any month since July, 1945, according to the American Iron & Steel Institute. July output was 6,598,864 net tons, at 84.7 per cent of capacity, compared with a revised figure of 5,624,826 tons in June, at 74.4 per cent. In July, 1945, production was 6,985,571 tons, at the rate of 86.3 per cent of capacity.

For the first seven months this year total production was 33,928,018 tons, compared with 50,128,653 tons in the comparable period in 1945. This decline was due mainly to the steel and soft coal strikes early in the year, and also to shortage of pig iron and scrap in later months.

STEEL INGOT PRODUCTION STATISTICS

Based on reports by companies which in 1944 made 97.6% of the open hearth, 100% of the bessemer and 85.8% of the electric ingot and steel for castings production

	Estimated Production—All Companies		—Open Hearth—		—Bessemer—		—Electric—		—Total—		Calculated weekly production all companies Net tons in mo.	Number of companies weeks
	Net tons	Per cent of capac.	Net tons	Per cent of capac.	Net tons	Per cent of capac.	Net tons	Per cent of capac.	Net tons	Per cent of capac.		
1946												
Jan.	3,528,090	51.1	207,512	47.4	136,452	29.2	3,872,054	49.6	874,053	4.43		
Feb.	1,300,944	20.9	25,905	6.6	65,668	15.6	1,392,517	19.8	348,129	4.00		
March ...	5,946,698	86.2	363,949	83.1	196,400	42.0	6,507,047	83.3	1,468,859	4.43		
1st qtr. ...	10,775,732	53.8	597,366	47.0	398,520	29.4	11,771,618	51.9	915,367	12.86		
Apr.	5,333,139	79.8	286,088	67.5	241,031	53.3	5,860,258	77.5	1,366,028	4.29		
May	3,699,979	53.6	153,409	35.0	219,064	46.9	4,072,452	52.2	919,289	4.43		
June	5,145,594	77.0	251,253	59.2	227,979	50.4	5,624,826	74.4	1,311,148	4.29		
2nd qtr. ...	14,178,712	69.9	690,750	53.7	688,074	50.1	15,557,536	67.9	1,195,814	13.01		
1st 6 mos. ...	24,954,444	61.9	1,288,116	50.4	1,086,594	39.8	27,329,154	59.9	1,056,403	25.87		
July	6,009,670	87.3	365,384	83.6	223,810	48.0	6,598,864	84.7	1,492,956	4.42		
1945												
Jan.	6,469,340	90.5	379,062	76.0	355,910	76.8	7,204,312	88.8	1,626,256	4.43		
Feb.	5,968,326	92.4	347,227	77.1	337,212	80.6	6,652,765	90.8	1,663,191	4.00		
Mar.	6,927,939	96.9	398,351	79.8	379,639	81.9	7,705,929	95.0	1,739,487	4.43		
1st qtr. ...	19,365,605	93.3	1,124,640	77.6	1,072,761	79.7	21,563,006	91.5	1,676,750	12.86		
Apr.	6,541,627	94.5	372,952	77.2	375,308	83.6	7,289,887	92.8	1,699,274	4.29		
May	6,664,117	93.2	402,100	80.6	383,450	82.7	7,449,667	91.8	1,681,640	4.43		
June	6,129,763	88.5	379,307	78.6	330,952	73.7	6,840,522	87.1	1,594,527	4.29		
2nd qtr. ...	19,335,507	92.1	1,154,859	78.8	1,089,710	80.0	21,580,076	90.6	1,657,730	13.01		
1st 6 mos. ...	38,701,112	92.7	2,279,499	78.2	2,162,471	79.9	43,143,082	91.0	1,668,688	25.87		
July	6,318,975	88.6	381,832	76.7	284,764	61.6	6,985,571	86.3	1,580,449	4.43		
Aug.	5,172,344	72.3	347,088	69.5	215,885	46.6	5,735,317	70.7	1,294,654	4.43		
Sept.	5,435,799	78.7	352,847	73.2	193,829	43.3	5,982,475	76.3	1,397,775	4.28		
3rd qtr. ...	16,927,118	79.9	1,081,767	73.1	694,478	50.5	18,703,363	77.8	1,424,475	13.13		
9 mos. ...	55,628,230	88.4	3,361,266	76.5	2,856,949	70.0	61,846,445	86.6	1,585,806	39.00		
Oct.	5,146,787	72.0	242,122	48.5	207,867	44.8	5,596,776	69.0	1,263,351	4.43		
Nov.	5,641,308	81.5	358,664	74.2	200,494	44.7	6,200,466	78.9	1,445,330	4.29		
Dec.	5,523,277	77.4	343,266	68.9	191,394	41.4	6,057,937	74.8	1,370,574	4.42		
4th qtr. ...	16,311,372	76.9	944,052	63.8	599,755	43.6	17,855,179	74.2	1,358,842	13.14		
2nd 6 mos. ...	33,238,490	78.4	2,025,819	68.5	1,294,233	47.1	36,558,542	76.0	1,391,646	26.27		
Total ...	71,939,602	85.5	4,305,318	73.3	3,456,704	63.4	79,701,624	83.5	1,528,608	52.14		

For 1945 percentages are calculated on weekly capacities of 1,614,338 net tons of open hearth, 112,658 tons of bessemer and 104,640 tons of electric ingots and steel for castings, total 1,831,636 tons; based on annual capacities as of Jan. 1, 1945 as follows: Open hearth 84,171,500 net tons, bessemer 5,874,000 tons, electric 5,455,890 tons.

For 1946 percentages are calculated on weekly capacities of 1,558,041 net tons open hearth, 98,849 net tons bessemer and 105,491 net tons electric ingots and steel for castings, total 1,762,381 net tons; based on annual capacities as of Jan. 1, 1946, as follows: Open hearth 81,236,250 net tons, bessemer 5,154,000 net tons, electric 5,500,290 net tons, total 91,890,540 net tons.

Surplus Tools Moving Slowly From Storage

Many difficulties beset disposal program. Paper work not yet prepared for many items

DETROIT

SALES of surplus machine tools and equipment from warehouses of the WAA have now been under way for nearly two months, but on many tools the necessary paper work including the required Form 70 has not been prepared, even after as long as a year. Beyond this, there seem to be unending difficulties besetting the entire program in this area.

First the agency ran out of funds at the end of June and had to borrow to make payments to truckers. Then a jurisdictional dispute between teamsters and riggers threatened to stop all movements of machines. Then a proposal to figure pricing on standard base prices and give away special tooling to dealers to cover cost of removing it was rescinded in favor of an attempt to realize 25 cents on the dollar for tooling, which proved unworkable. Then the requirement for written inquiries to be received in order to put "hold" tags on tools was dropped, with the result a flood of dealers and agents descended on warehouses requesting "hold" orders on machines before they were even sold.

As surplus sales proceed, it is often necessary to make substitutions in requests for specific type of machine—one make for another, etc. Being unfamiliar with the different makes of machines, the WAA staff is unable to handle such substitutions effectively and sales are slowed.

Warehouse No. 9 here is clogged with 223 acres of equipment, only half of it under roof. More is moved in as fast as disposals are made and equipment out in the open is at the mercy of the elements except for tarpaulins. It is difficult to persuade operators of the warehouse to remove tarpaulins to show the machinery unless an actual customer is on hand, and there appear to be no plans to erect protective covering before winter.

Higher Prices Expected on Tools in Pittsburgh Market

Pittsburgh—Lifting of price ceilings is expected by machine tool builders. Since April 19 last, when the industry was permitted to raise prices up to 20 per

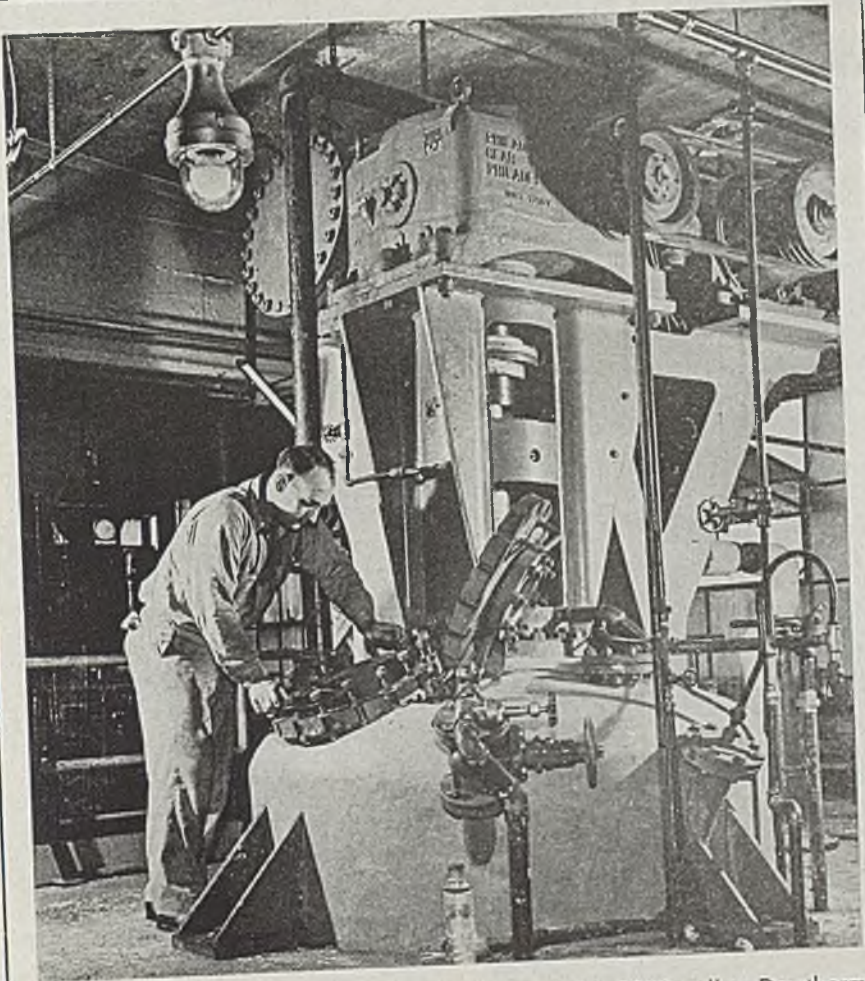

INCREASES ENAMEL OUTPUT: Completion of this 1000-gallon Dowtherm kettle, just installed by the Arco Co., Cleveland, for production of synthetic resins breaks one more bottleneck which has slowed production of household appliances. This unit and another of equal capacity are used to turn out resin used in making synthetic finishes with greater resistance to water, heat, alkali, acids and grease than prewar enamels

cent, advances ranging from 6 to 16 per cent have been established on standard tools and up to the maximum of 20 per cent on larger special equipment. The industry has been doing everything possible to hold prices down but increased production costs are expected to force an additional advance of 10 per cent in heavy machinery items.

Supply Position of Machine Tool Builders Improving

Cleveland—A marked improvement in shipments of raw materials and components to the machine tool industry is noted. Various shortages which had become critical during the second quarter and had threatened a curtailment of production have been corrected, although electric motors and certain types of steel, such as tool steel, remain tight.

Supplies of castings which were at one time at the top of the critical supply

list have loosened up and are now being shipped in adequate amounts to support the current rate of machine tool building. Bearings have also become more readily available.

Some experts in the trade believe the recent slump in new demand is directly attributable to the aggressive sales program for machine tools which is being carried out by the War Assets Administration.

Builders Expect To Step Up Tool Production Soon

Cincinnati—A step-up in production will be sought soon by machine tool builders here to achieve a better delivery position. Labor troubles have faded and vacations are out of the way but impending scarcity of skilled labor and of critical materials and equipment may block expansion plans. New ordering is rather spotty.

Changes Urged In Wagner Act, NLRB Procedures

Gerard D. Reilly, retiring from board after five years, suggests more freedom of speech for employers

CHANGES in Wagner Act and the procedures of the National Labor Relations Board to clarify the status of supervisory employees and to give employers greater freedom of speech in organization campaigns were recommended by Gerard D. Reilly last week as he retired after five years' service with the NLRB.

Mr. Reilly frequently has differed sharply with his colleagues on the board on questions involving the unionization of foremen and on how much employers should be allowed to say to employees about unionization.

The retiring board member said he believes the Wagner Act is basically sound as the foundation of a national labor policy, but added that it would be more effective if it eliminated secondary boycotts and strikes for representation and illegal objectives.

Mr. Reilly suggested six changes, two in NLRB procedure and four alterations in the Wagner Act, which would require congressional approval.

The NLRB, he said, should:

1. Give to employers the right to petition for bargaining elections where a union claims bargaining rights and threatens to strike without resorting to NLRB procedure. Under present rules, an employer can petition only if two or more unions are contesting for representation.

2. Accord to employers the right, co-relative with the unions, to speak freely during union organizing campaigns, the only condition being that employers do not intimidate or discharge employees engaging in union activity. "I think the employer should have the right to speak pretty freely to his employees about the long-term effect of unionization of his plants co-relative with the right of the union to say anything it pleases."

Mr. Reilly suggested these changes in the Wagner Act:

1. Clarification of the status of supervisory employees. No administrative agency should have the authority, he contended, to certify such employees in bargaining units since the subject was never discussed during debate and enactment of the Wagner Act.

2. Withdrawal of protection of the act from unions which strike for objectives contrary to the act or which could be achieved by orderly processes under the act. This protection consists of the right of reinstatement with back pay for employees.

3. Grant to the NLRB the power to cope with unions engaging in secondary boycotts, such as the refusal of the

Teamsters Union-AFL and the Longshoremen and Warehousemen-CIO to unload AFL-manned ships at Coos Bay, Oreg.

4. Transfer the prosecuting and NLRB enforcement functions to the Department of Labor. This step, he said, would make the board only a fact-finding and judicial body and increase public confidence in its impartial functions.

Maritime Union Calls Strike Against Lake Shipping; Threatens Ore, Coal Movement

EFFECTIVENESS of a Great Lakes shipping strike called by the National Maritime Union Aug. 15 remained in doubt at week's end. The NMU, which has contracts with companies operating less than 10 per cent of the total bulk freighters on the lakes and which ship operators say represents only about 5 per cent of the men sailing the lakes, is asking for a 40-hour week instead of the present 56-hour week, pay increases and other concessions.

Whether or not the NMU will be able to make the tieup of lake shipping effective depends on the extent to which they can influence other unions at ports and terminals and the non-union seamen. At week's end the situation was spotty, with some shipping being interrupted and some proceeding as usual.

The NMU imported pickets and other strike workers from salt water ports. The union claimed to have \$1,000,000 earmarked for the strike and was preparing to set up "soup stations" at lower lake ports for the strikers.

Ship operators contended the union's demand for a 40-hour week was only camouflage for a demand for more wages, other than those contained in their straight time demands. Nature of lake shipping, they hold, makes a 40-hour week unfeasible.

The NMU has been attempting to organize Great Lakes shipping for several years, but has met with poor success.

Despite the lack of strength of the NMU on the lakes, it was considered possible that the strike could seriously hamper the movement of iron ore, coal



Joseph Curran, left, president of the National Maritime Union, which called a strike against Great Lakes shipping, confers with Secretary of Labor Schuellenbach, center, and Harry Bridges, head of the Longshoremen & Warehousemen Union, right. NEA photo

and other commodities, already lagging behind normal. Some speculation on the possibility that the government might seize lake shipping should the tieup be effective was heard in shipping centers.

Lamson & Sessions Strike Settled After 117 Days

A strike of 117 days duration at the Cleveland plant of the Lamson & Sessions Co. was ended last week when workers voted to accept a compromise wage proposal providing for an increase of 17 cents an hour retroactive to Mar. 1. Union officials said 97 per cent of the workers approved the proposal. About 1000 workers are affected.

The compromise settlement provided for dues checkoff but did not include a closed shop provision which had been sought by the union, the United Automobile Workers.

Government Won't Seize Strike-Bound Case Plants

President Truman has decided against federal seizure of the strike-bound plants of the J. I. Case Co. as not being in the public interest, the White House announced last week.

The closure of the farm machinery company in Racine, Wis., does not constitute a national emergency of the character warranting seizure, the President believes. White House spokesmen said it was reasonable to believe the same attitude would be taken regarding the Allis-Chalmers plants at West Allis, Wis.

Subsidy Purchasing of Sheet Bars Revived by RFC

Reconstruction Finance Corp. is reported to have made new agreements for purchasing sheet bars from Jones & Laughlin Steel Corp. and Sharon Steel Corp. to be resold to four nonintegrated sheet mills.

The agreement with Sharon provides for the purchase of 180,000 tons by Dec. 31 to be distributed equally among the following companies: Superior Steel Co., Canton, O.; Reeves Steel Co., Dover, O.; Apollo Steel Co., Apollo, Pa.; Mahoning Valley Steel Co., Niles, O. The RFC will pay a subsidy aggregating not more than \$1,500,000 at a rate of \$7 a ton and the freight differential.

The Jones & Laughlin agreement includes 25,000 tons to be purchased over three months. Selling price to the small companies, the same as covered in the Sharon agreement, will be \$38 plus the freight differential; the RFC will pay J. & L. \$45.84 a ton, the ceiling price.

Canada's Metalworking Plants Receiving Only 25% of Steel Needs as Strike Continues

TORONTO

STALEMATE has developed in the Canadian steel strike and settlement appears no closer than it was four weeks ago. The steel companies, Steel Co. of Canada Ltd., Algoma Steel Corp., and Dominion Steel & Coal Corp. Ltd., have declined to raise their wage increase offers, and the union leaders show no disposition to soften their demands.

Of the big three steel producers, the Steel Co. of Canada Ltd., Hamilton, is the only one producing iron and steel. Stelco has commenced shipments of steel from its Hamilton works, taking the finished materials out by boat, as the railways refuse to run the picket lines. The first shipment was reported leaving the Hamilton plant on Sunday night for an undisclosed destination. From the beginning of the strike ships have been unloading iron ore and coal at the Stelco docks on plant property, but this is the first time vessels have been used to ship steel out of the plant.

Stelco has been steadily stepping up production of both iron and steel and last week announced the blowing in of a second blast furnace. According to word from Hamilton about 2700 workers are now operating within the plant grounds

against just over 2000 at the start of the strike. Workers are reported receiving 24 hours pay for an 8-hour work-day.

Lack of steel deliveries to many plants in Canada is having telling effect on civilian production schedules. This week Massey-Harris Co. laid off 5000 workers because it lacked steel to maintain agricultural implement production. Railroad rolling stock and locomotive builders are slowing down on production lines and it is reported that they are not taking on new export business.

The steel supply situation in Canada is tightening rapidly and despite some improvement in imports of both pig iron and finished steel from the United States, the supply is less than 25 per cent of actual needs. While several companies have laid off thousands of workers due to steel shortage, substantially greater lay-offs and shutdowns are expected before the end of this week.

Foundry operations in Canada also have been seriously affected by shortage of pig iron with no deliveries from the three big producers, and only a small percentage of requirements being filled by Canadian Furnace Co. at Port Colborne and by imports from the United States.

GOVERNMENT CONTROL DIGEST

OFFICE OF PRICE ADMINISTRATION

Warehouses: Warehouse resellers of alloy steel products, screen wire cloth, nails, brads, staples and bale tie wire may add to their maximum prices the amount of increases recently granted producers.

Resellers of iron and steel products who truck them to buyers at a cost less than that of ordinary freight need not deduct the resultant savings from their ceilings unless trucking services were specifically requested by the buyer. Warehouse resellers are also permitted to include in their maximum prices for prime hot and cold-rolled steel sheets and strip the specified extras for drawing quality. Galvanized and galvanized sheets, long terne and enameling sheets have been added to those products for which the drawing quality extra is allowed. (MPR-49; OPA-T-4871)

Cast Iron Soil Pipe: An increase of 2 per cent, or \$1.75 per ton, for cast iron soil pipe and fittings became effective Aug. 13, reflecting increases in costs since May 25 when OPA allowed an increase of 6.5 per cent. (RPS-100; OPA-T-4884)

Kitchen Utensils: Ceiling prices on cast iron and enamel kitchen utensils increased 5 per cent, effective Aug. 5. (MPR-188; OPA-6677)

Grain Machinery: An interim increase of 8 per cent over base date maximum sales price for producers of grain machinery and equipment authorized July 26. (MPR-136; OPA-T-4789)

Brass Screw Machine Products: An interim additional increase of 1.9 per cent in ceiling prices of screw machine products made entirely of brass made effective Aug. 8. (MPR-136; OPA-T-4852)

Nonferrous Bushings and Bearings: Prices for nonferrous bushings and journal and sleeve

bearings increased, effective Aug. 8, from 1 to 2½ cents per pound. (MPR-136; OPA-T-4850)

Ground Coal: Sales of ground coal used for foundry facings and dealer sales of bagged smithing coal as well as the service of bagging smithing coal have been exempted from price control, effective Aug. 8. The ground coal exemption applies to both ground bituminous coal and ground anthracite or car wheel mineral. (MPR-166; OPA-6664)

CIVILIAN PRODUCTION ADMINISTRATION

Building Materials: Nails, specified builders hardware, specified electrical wiring devices, metal doors and frames, metal window sash and frames, metal plaster base, boilers (low-pressure, residential types) furnaces (floor and wall), and registers and grilles for heating systems have been added to schedule A of priorities regulation 33, permitting issuance of "HH" ratings to assist procurement for the Veterans' Emergency Housing Program. Nails, builders' hardware and electrical wiring devices were added to the list of materials for which "HHH" ratings may be granted to veterans' temporary reuse housing project contractors. The "HH" and "HHH" ratings for nails have no effect on orders placed with producers, being effective only against distributors.

Nails have also been added to list 1 to direction 8 of PR-33 which includes materials for which prefabricators may get "HH" ratings for the manufacture of prefabricated houses.

Direction 11 to PR-33, covering special assistance for veterans' temporary reuse housing projects, was amended to permit producers of certain materials to charge AAA-rated deliveries against the 20 per cent ceiling provision on certified HH-rated orders. (PR-33; CPA-517)

Windows of Washington

Trimming of wartime bureaucracy back to peacetime dimensions slow and painful process. Federal Pay Act calls for reduction of several hundred thousand government employees by next July. Extent of severances uncertain

DEMOBILIZATION of the wartime bureaucracy created to steer economic affairs on the home front is proving a more prolonged process than generally had been anticipated.

Here it is a year since the fighting war ended and many of these war-born agencies are still functioning at the old stand. True, there has been considerable watering-down of operations, and more of the same is in the offing, but Washington still is cluttered with a long list of offices and bureaus sprawled through various buildings and spilling over into the White House, all ostensibly concerned with the job of liquidating the war program and jacking the economy back into its peacetime groove.

All of which adds up to the fact that the alphabet bureaucracy is far from dead, still employing thousands, and grinding out directives, regulations and press releases by the ream.

Some of these wartime agencies are operating under new names—the War Production Board being an outstanding example in this respect, it now being the Civilian Production Administration. Also, numerous bureaus have been merged to reduce the listings in the official government directory. However, since end of the war several new agencies have arisen

to assume direction of certain reconversion programs, these newcomers serving to offset the savings expected through liquidation of wartime bureaus.

Of course, the complexion of these agencies has changed. Only a few of the old timers on the top personnel level remain on the job, they having pretty well cleared out of Washington in favor of their old positions in private industry or moved on to other posts in government. Actually, life in these bureaus is a rather tame affair compared with the hustle-bustle of wartime. No longer is the Social Security Building, home of the old War Production Board, the busy hive it once was. Businessmen are not coming to town as often as they did in the old days and the boys and girls in the various bureaus are not under the pressure they once were.

Right along there is a lot of office shifting and personnel changing going on. In fact, guards in the Social Security Building are somewhat confused by the goings on, not knowing from one day to the next where this or that office is located. It must be a lot of "fun" for them steering perplexed visitors about the ornate structure.

How long will these war agencies last? Well, no one seems to have the answer

to that one. Best view is that at least a year will pass before they wash out, and some may linger on much longer. Top officials say they are anxious to rid themselves of their jobs, close up shop and get back to their own businesses in private life. But all insist that there still is a lot of work that remains to be done before the country gets back to normal. This is probably true, though the thought persists that a great deal of this reconversion work could be shifted to permanently established government agencies without sacrifice of efficiency.

It is clear that many war agencies are going to be with us much longer than we had bargained for. Certainly, the new lease on life which the Office of Price Administration was able to wring from a reluctant Congress, would seem to support the idea that wartime bureaucracy is not going to quit without a fight, all pious statements of the bureaucrats to the contrary notwithstanding.

Large Cutbacks in the Offing

One encouraging feature of the situation is that not only has considerable headway been made toward winding up affairs in certain directions but the next few months may see some severe pruning of the bureaucratic tree generally. Such pruning is expected to result in terminating thousands of employees from government payrolls over the next year. The paring knife is being applied to expenses not only upon the urging of President Truman but because such retrenchment is made necessary under the Federal Pay Act which also provides a 14 per cent hike in pay for federal employees.

The Federal Pay Act carries a "reduction-in-force" amendment calling for reduction of several hundred thousand in federal employees by July 1, 1947. At present the government payroll numbers 2,322,000 employees. However, there is a conflict between the Dirksen amendment to the Pay Act and the Third Deficiency Act which may prove to be a job-saver for thousands now on the payroll.

It appears that while the Dirksen amendment was passed in June providing for reduction in forces, the Third Deficiency Act, enacted later, gives the Budget Bureau discretion in determining the rate of layoffs. Whether the Deficiency Act supersedes the intent of the Dirksen amendment is a question which must be settled before the ax falls.

The Third Deficiency Act states it is not the intention to alter or modify the personnel ceiling set up under the Dirksen amendment and that any increase in personnel granted one agency must be



Judge John Caskie Collet, left, confers with Reconversion Director Steelman with whom he will be associated in directing reconversion activities. Judge Collet will have no formal title but will occupy an office adjoining Steelman's in the east wing of the White House. NEA photo

The CONE AUTOMATIC MACHINE COMPANY



sees many

GOOD THINGS AHEAD

"ENIAC", the electronic computer developed for the Ordnance Department, can do 100 man-hours of mathematical work in two hours. It is expected to revolutionize the mathematics of engineering.

get ready with CONE for tomorrow

American Optical Company has developed a sight-testing instrument which will make 14 vision tests in three minutes.

get ready with CONE for tomorrow

Beech Aircraft is developing a 6-passenger automobile with a 90-horsepower air-cooled engine that drives a generator powering separate electric motors on the wheels.

get ready with CONE for tomorrow

Martin Senour Company has developed a method of paint mixing that will produce 1000 tints with accuracy from 6 basic colors. The idea is being tested at a "paint bar" in a metropolitan department store.

It is reported that

President Buckley of Bell Telephone Laboratories describes a television tube no bigger than a pocket flashlight.

get ready with CONE for tomorrow

The new building of the American Stone Company in St. Louis will have an electrically controlled car suspended from the roof for washing windows.

get ready with CONE for tomorrow

A plastic molding press weighing 17 lbs. and costing about \$30 is offered by N. R. K. Manufacturing & Engineering Company of Chicago.

get ready with CONE for tomorrow

International Business Machines has a 6-key Braille typewriter and will give away the first thousand to blind veterans.

get ready with CONE for tomorrow

Du Pont has announced a new, improved translucent "metallic" lacquer for automobiles called "Metalli-Chrome"

get ready with CONE for tomorrow

Two former military pilots have established American Flyaway Service, at Dayton, Ohio, to deliver personal aircraft from manufacturers to dealers.

get ready with CONE for tomorrow

On its longest over-water run, Oakland to Honolulu, Naval Air Transport Service is landing its planes within 18 minutes of their schedule.

get ready with CONE for tomorrow

In the upholstery plant of Fisher Body, the annoyance and danger of static electricity was eliminated by humidification. An incidental benefit was reduced absence due to colds.

International Harvester is establishing a manufacturing research center with 350 men chosen from its plants all over the country.

get ready with CONE for tomorrow

Westinghouse has a bacteriacidal ultra-violet lamp to insert in milk cans that reduces bacteria count 96% in one minute.

get ready with CONE for tomorrow

The 6-mile canal dredged to supply the Dow magnesium plant at Velasco, Texas, with sea water is also serving as a freight artery.

get ready with CONE for tomorrow

Tucson Laundry Company has started twice-a-week laundry pick-up service by air over a distance of 60 miles.

COMPLETELY

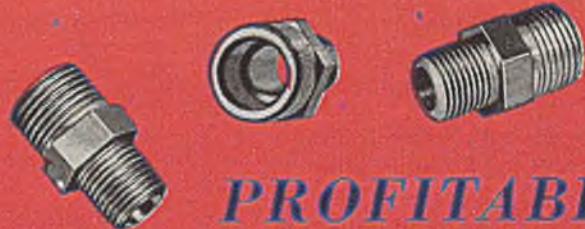

PROFITABLY

The brass fitting illustrated is machined on a $\frac{3}{8}$ " 4-spindle Conomatic in 6 seconds. For machining parts completely and profitably, purchase Cones.

Ask your CONE representative to show you our new color motion picture

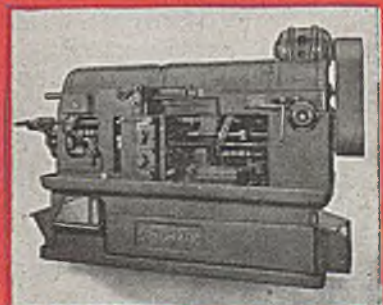

CONE

AUTOMATIC MACHINE CO., INC. ★ WINDSOR, VERMONT, U.S.A.

offset by a cut elsewhere. However, it includes a provision that gives the director of the Budget Bureau discretionary power in terminations, stating that if he shall find and certify to the President that any offsetting reductions would be inimical to the public interest, "such offsetting reduction, subject to the President's approval, may be waived in whole or in part."

For the past two weeks federal agency heads have been meeting in closed sessions with Budget Bureau officials seeking ways and means of warding off the drastic personnel cuts ordered under the Pay Act. However, some departments have started chopping staffs, the War Department already having notified 3500 civilian workers they will be dismissed by Oct. 31. Both the Army and Navy have until July 1 of next year in which to reduce their civilian forces but other federal departments and agencies must reduce their staffs on a quarterly basis. At present these latter agencies have about 540,000 employees, and by Oct. 1 under the Dirksen amendment they must have lopped off some 12,000 from the payroll to 528,000. By Jan. 1 they must cut the number to 501,771, by April 1 to 474,000 and by July 1, 1947, to 447,363.

The retrenchment program for the moment at least is resulting in a high degree of tension in the ranks which may have serious repercussions on department efficiency. Another point made in this connection is that in the sifting out process many essential bureaus may be so denuded of competent employees it will be impossible for them to operate effectively.

Where dismissed employees will find new employment is not known, but the general view is that many will obtain jobs in other government agencies which have been understaffed in certain clerical categories. Actually, right now there is a severe shortage of many classes of office workers in Washington, particularly typists and stenographers, and indications are that many such employees will quickly catch on elsewhere, simply transferring from one agency to another. At present, however, the United States Employment Service reports there are only 5000 job openings in the Washington area, about half of them for women.

OES and OWMR Merged

Illustrative of the trend toward consolidation and integration of the remaining war and reconversion effort is the action last week of Reconversion Director John Steelman merging the Office of Economic Stabilization into the Office of War Mobilization & Reconversion. In the new setup Federal Judge John C.

Collet, just called back to Washington from the bench in Missouri, will serve as an associate to Steelman in an overall capacity. While his office will not rank a title, it is expected Judge Collet will assume a lot of Steelman's load, which, admittedly, is terrific. Several other changes in the OWMR lineup have been effected, key post in the general administrative reorganization, that of deputy director for production, stabilization and war liquidation, going to Harold Stein who has been in the agency since the days when Chief Justice Vinson was in command of the war mobilization and reconversion machine. Two other deputies have been appointed, Donald Kingsley being placed in charge of fiscal policy, employment and social security, and Anthony Hyde being named to the information and reports post.

Through these changes Steelman effects a three-way division of responsibility, and he anticipates that integration of OES and OWMR will eliminate considerable duplication of effort, tend for greater efficiency in reconversion matters, and reduce bureau expenses.

Bureaus Moving Back

In the frenzied days of war not much attention was paid to the fact that many important agencies devoted to peacetime activities were moved out of Washington to make room for new-born war bureaus. This naturally resulted in considerable dispersal of activity, some agencies having certain bureaus in one city and other bureaus elsewhere. With the war over, however, moves are under way to bring back some of these offices to Washington. A case in point concerns the Patent Office.

Last week President Truman was personally appealed to by a prominent patent attorney to reconsolidate all divisions of the Patent Office in Washington. It will be recalled that early in the war all examining divisions of the Patent Office and the classification and interference divisions were moved from Washington to Richmond, Va. Since the war ended something like 28 examining divisions and the classification and interference divisions have been returned to Washington, but 37 examining divisions still remain in Richmond.

In the appeal to President Truman to use his personal influence to see that these remaining divisions are returned to Washington, it was pointed out that the Public Buildings Administration, which controls official government office space, although provided with funds to restore the patent divisions to Washington, has failed to provide the available space though it has been returning some office space to private owners.

The President's attention was called to the fact that a tremendous number of patent applications are awaiting action and great delay in processing these is encountered due to the splitting of the Patent Office's activities between Washington and Richmond. Patent Office figures show that between mid-July, 1945, and mid-July, 1946, the Patent Office backlog of applications awaiting action increased 81 per cent to 117,934.

Premiums for Soil Pipe

One of the most critically short of all building materials is cast iron soil pipe. Housing Expediter Wilson W. Wyatt has been working overtime to relieve the shortage and last week his office came up with the prediction soil pipe production will rise sharply from now on as a result of Premium Payments Regulation No. 8, just issued. The plan, together with recent increases in pig iron allocations to the industry, is expected to expand production of pipe, fittings and accessories by 50 per cent, approximately 180,000 tons, during the 11-month life of the regulation. An immediate increase of 20 per cent is expected.

Officials estimate the extra production will be sufficient for several hundred thousand of the 2,700,000 homes and apartments scheduled to be started by the end of 1947 under the Veterans Emergency Housing program. Generally, the premiums amount to \$40 per ton on all Saturday production in excess of quota, provided that Saturday is the sixth day worked during the week, and \$10 per ton for all other production in excess of quota. The most immediate method of boosting output is to shift to a 6-day work-week. In the past the industry has found it difficult to produce profitably beyond the 5-day week, and the \$40 Saturday premium will compensate producers for extraordinary expenses incurred in six-day operation.

WAA Forming Metalworking Machinery Committees

Establishment of a national committee on metalworking machinery and equipment, to stimulate sales of this type of surplus property, has been announced by the War Assets Administration. Similar committees, to serve in an advisory capacity, will be established in each of WAA's 33 regional offices.

The national committee is representative of the contract dealers as to size, geographic location, membership in trade organizations and the three segments of the industry (manufacturers, dealers in used machinery and equipment and dealers in new machinery).

French Wages To Be Increased 17%; Income Tax Exemptions To Be Raised

Private enterprise generally will not be permitted to advance prices. May be granted subsidy by state. Nationalized industries will raise prices. Freight rates to go up 35 per cent; electricity, 40 per cent; gas, 27 per cent

PARIS, FRANCE

Committee of the National Economic Council which is investigating wages and prices and which comprises representatives of employers and workers has been examining the claims for a general increase of wages of 25 per cent set forth by the "Confederation Generale du Travail," the French trade unions council, and the effect that such a rise would have on prices.

It is the first time that such a meeting has taken place, and it has resulted in complete agreement.

As a result of the discussions it has been decided that wages would be increased by an average of 21 per cent. The C. G. T. had requested that this increase of wages should not be followed by an increase in prices, their argument being that in many cases French industry had considerably increased its output. However, it was found that this request could not be granted for industry as a

whole. In view of the desire to avoid inflation it was decided that in cases where the increase of wages could not be met the state would be asked to establish a subsidy. This would be the case for food products and essential articles of consumption.

The resolutions of the committee were placed before the government and after long discussions it was finally decided that the average increase of wages would be about 17 per cent. To breach the gap between the rate recommended by the committee and the rate adopted by the government it was decided to increase the income tax exemption from 40,000 frs (\$335) to 60,000 frs, (\$500), and to increase family allowances by 50 per cent.

It is to be noted that while private enterprise is not allowed, in principle, to increase prices, nationalized industries will do so on the plea that "as they do not make profits arising out of the capitalized system they must balance their

budget without financial assistance from the state." As a result there will be an increase of 35 per cent on freight rates, 10 per cent for passenger rates on the railroads, 40 per cent for electricity, 27 per cent for gas, and to meet the requirements of farmers the price of wheat is increased and also, as a consequence, the price of bread. It remains to be seen how workers will react to these increases. It is presumed that these price increases will be absorbed without much difficulty if there is a substantial general increase of output. Otherwise the fears of inflation are likely to be confirmed.

As far as the iron and steel industry is concerned, the output in June has increased in regard to pig iron, but has remained stationary as regards steel. For pig iron production in June was 264,000 tons as against 252,000 tons in May. The output of steel ingots and castings was 341,000 tons in June as against 342,000 tons in May.

Output of electric steel is now higher than prewar as it does not depend on coal. A supplementary quota of coke has been promised for the month of August, but the iron and steel industry is suffering from a shortage of lime and the factory materials. During the twenty-seventh week of the year coal output dropped to 936,000 tons as against 955,000 tons in the preceding week. Coal imports have increased slightly although deliveries from the Ruhr were less than expected.

British Steel Prices To Rise Five Shillings

LONDON

An increase of approximately five shillings a ton on heavy steel products to compensate for higher production costs is expected to be announced this week. The new price rise will be the first since December, 1945, when the general level of finished steel was increased about 5 per cent.

In pointing out that the costs of making heavy steel products have increased about 10 shillings a ton since last December, the July issue of the monthly statistical bulletin of the British Iron & Steel Federation says: "It is unlikely some adjustment in steel prices to meet advances in wages, railway rates and other items can be avoided although the efforts of all concerned are directed toward insuring a maximum stability in prices and avoiding increases wherever possible."

While the new price increase will not make up the entire rise in production costs, it will help alleviate charges that the industry cannot escape. The industry believes it will be able to make up the remainder itself.



NEW BELGIAN CABINET: Members of the new Belgian cabinet pose for their first photograph. Left to right, front row: Joseph Merlot, minister of finance; Paul Henri Spaak, foreign affairs; Camille Huysmans, prime minister. Rear row: Jean Terfve, minister of reconstruction; Leon Troclet, labor; Lt. Col. DeFreiter, national defense; Edgar Lalmand, food; Albert Marteaux, health; and Ernest Rongvaux, communications. NEA photo

Technical Aid Agency Set Up

A BASIC DECISION by Secretary Henry A. Wallace's newest unit in the Commerce Department—The Office of Technical Services which came into being on July 1—should be of more than usual interest to businessmen. It is that the OTS will render to business and industry only such services as the government properly should render, and it will under no circumstances engage in competition with private industry.

Possibly such a decision should have been expected. If it is not a surprise, however, it is most reassuring as indicating a trend. For the Office of Technical Services is opening up virgin soil in many respects; it is preparing to render services of a type never before provided in peace time. Because, among other things, it has taken over some of the wartime functions of the government, it might easily have sought to perpetuate in time of peace the methods by which government regimented industry during the war. This it definitely has decided not to do. It will not engage in competition with the many firms that render managerial, financial, sales, advertising, accounting, tax and numerous other types of service to business.

Idea Widely Approved

The new office was created in part in fulfillment of a dream conceived in the Commerce Department many years ago that there should be one place in the government to go for answers to all kinds of technical questions. Experience in the war proved beyond a doubt that the government can be tremendously effective in stimulating technological progress. When Secretary Wallace appeared before the House and Senate Appropriations Committees to prove a case for his budget request for the fiscal year starting July 1, he had no difficulty in showing to the satisfaction of the congressmen that by performing certain technical services for industry and business, the government might do a lot to encourage business and employment.

Plans of the OTS are almost entirely in the blueprint stage yet and there are many questions to be answered before they can take final shape. The OTS has six divisions, either in existence, or in the embryo stage. Four of them came to the OTS as transfers and two of them are brand-new. They are:

1—The Invention and Engineering Division, created July 1 to do for civilian industry what the National Inventors Council did for the military during the

Commerce Department's new Office of Technical Services is to provide assistance that will encourage business and employment but has announced that in doing so it will avoid competing with private industry

war and continues to do in evaluating ideas and stimulating invention for strictly military purposes. Purpose of the IED is to evaluate ideas and stimulate invention that will aid the economy and provide widespread employment.

2—The Technical Inquiry Service, so new that it still is largely a paper organization. Its creation springs from the desire to have a place in the government where the answers to technical questions may be obtained.

3—The Technical Advisory Service, transferred from the old Smaller War Plants Corp. to the Office of Technical Services. While detailed plans still are to be worked out, one decision has been reached at the start. Whereas the Technical Advisory Service of the SWPC recruited a lot of experienced men from industry and pursued an all-out policy in furnishing technical advisory assistance to put maximum drive behind the war effort, the TAS will refrain from rendering any services in competition with private industry. Technical questions will be answered on the basis of information in the possession of the government. When questions are received which cannot be answered satisfactorily out of the government's store of information, the questioners will be referred to private firms, colleges, etc., that can furnish the answers.

New Division To Replace OPRD

4—The Industrial Research and Development Division, the peacetime counterpart and successor of the War Production Board's Office of Production Research and Development. When the OPRD was transferred to the Commerce Department for dissolution, Secretary Wallace went before the Appropriations Committees of Congress and asked authority to continue it permanently. He told of the fine record of the OPRD in evaluating ideas and inventions, and in developing new information and perfecting new and improved processes that added materially to the impetus of the war production effort, and he recommended that the organization be continued along the same lines to stimulate business and employment in peacetime. As a result, Congress earmarked \$1,500,000 for the Industrial Research and De-

velopment Division to be spent on research and development work to be done under contract by the Bureau of Standards and by land-grant colleges and nonprofit institutions when possible, and by other contractors when necessary.

5—The Technical Industrial Intelligence Division, the wartime agency known as the Technical Industrial Intelligence Committee of the Joint Chiefs of Staff. This is the agency that has sent teams of engineers and technologists to Germany to study German industry and write reports on their observations and discoveries. The TIID has sent some 400 expert observers to Germany, and will continue to send others there for the same purpose. The present program calls for completion of the work during the present fiscal year, so the TIID may shut up shop June 30, 1947.

OPB Renamed

6—The Library and Reports Division, formerly known as the Office of the Publication Board which was set up following the war to disseminate to private industry the declassified technical information accumulated by the Army, Navy, Office of Scientific Research and Development and other agencies during the war, and to make available also the reports on enemy technology developed by the Technical Industrial Intelligence Committee. LARD publishes weekly a bibliography which lists the reports as they become available and which describes them in brief abstracts and lists their prices.

The units known as the IED and the IRDD now are working with the National Housing Agency to promote the housing program. They are studying new building materials and methods, with much of the development work to be done at the National Bureau of Standards. Private individuals and firms having ideas about new or improved building materials and methods are invited to get in touch with these units of the Office of Technical Services. As the new ideas for materials and methods crystallize as a result of actual tests, full information will be turned over either to industry in general or to companies which have initiated the successfully developed ideas.

The work of the Library and Reports



Looking over plans for the Commerce Department's new Office of Technical Services are John C. Green, seated, director of the new office, and Robert Frye, assistant director of the new agency

Division is not progressing as rapidly as it might. This comes about, first, because the work is of great scope—LARD already has prepared 30,000 reports for dissemination and this number will grow to between 2 million and 3 million before the work is done. Second, now that the war is over, it is difficult to enlist the services of trained men capable of evaluating the contents of the reports. Third, LARD does not offer opportunity for a career for it is slated to pass out of existence when its job of reviewing and publishing wartime technological information has been done.

At the same time, the indifference of industry is in large part responsible for the halting progress in disseminating the reports which LARD places on sale.

LARD officials admit that not all the reports can benefit industry, and that the really valuable reports probably comprise a rather small percentage of the total. Their big difficulty is to carry out their assignment of conveying the information in these reports to industry, so that the economy will benefit.

There are two ways in which industry

could co-operate to make the program more effective. One way would be to have each industry's technical society appoint committees to examine and evaluate the reports.

The other way is for more American production men and technologists to travel to Europe and conduct their own investigations. This they can do as wards of the Office of Technical Services' Technical Industrial Intelligence Division. They must enter into two stipulations: That their expenses will be paid by themselves or by their employers, and that they will furnish written reports on developments of technological significance uncovered on the trip. The TIID arranges their transportation, helps chart their itineraries, gets them entree into industrial establishments and sees to it that adequate living quarters are provided and their varying needs attended to along the line of travel.

Many industrialists have been under the impression that those going abroad to study foreign industries do so at the instance and special invitation of the government. While the majority of tech-

nologists going abroad have done so on the initiative of the government, the gates are wide open. Any American business man desiring to go to Europe can get the wheels started by writing to the Office of Technical Services, Commerce Department, Washington 25.

Director of the Office of Technical Services, the appointee of Secretary of Commerce Wallace, is John C. Green, who graduated from the United States Naval Academy as an engineer and from Georgetown University in patent law. For five years he worked as an examiner in the Patent Office and then engaged in private practice as a patent attorney. During the war years he served under C. F. (Boss) Kettering as executive secretary of the National Inventors Council and in that capacity was the liaison with all government agencies doing research work. Since last fall he has headed the Office of the Publication Board, now the Library and Reports Division of the Office of Technical Services.

Mr. Green is in Europe investigating potentialities for future intelligence work in the field of technical information.

HOW BULLARD CUT MASTERS DUPLICATE DIMENSIONS SAFELY AND CONSISTENTLY

Bullard's skill in applying electrical-hydraulic control systems to machine tools...as exemplified by the Cut Master Vertical Turret Lathe's revolutionary new Pendant Control... is further illustrated by Bullard's method of dimension control through electrical and hydraulic feed stops.

On the saddle of each head of the Cut Master V.T.L., Bullard puts accurate adjustable dogs which are set to dimension limits for work size. When contacted by the moving head, they start a train of mechanical, electrical and hydraulic actions that disengage feed... instantly and accurately, thereby providing automatic sizing of work.

Such an automatic control system not only means that dimensions are easily duplicated but also that no head of a Bullard Cut Master Vertical Turret Lathe ever over-runs the cut or bumps any other head. Other reasons why Cut Masters are the surest means of *cutting time* on and between cuts are covered in Bulletin CVTL-4-1-46. Write for it today. The Bullard Co., Bridgeport 2, Connecticut. ♦

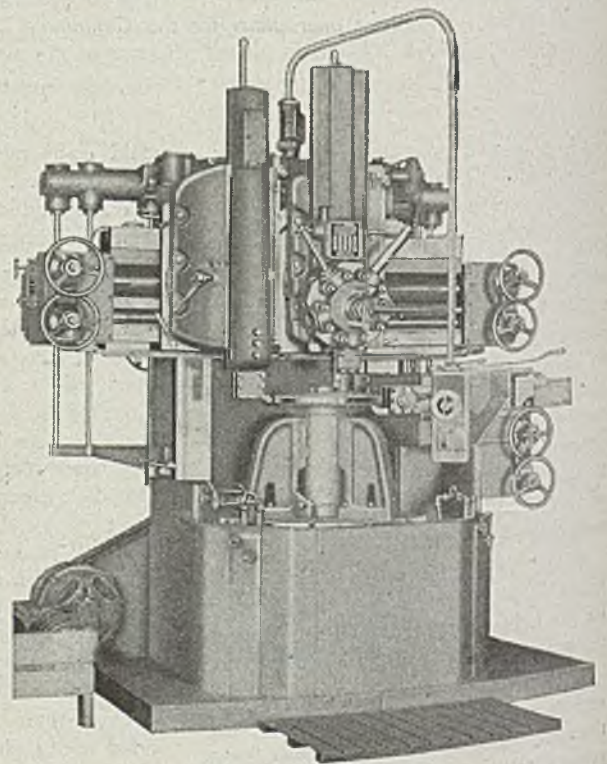
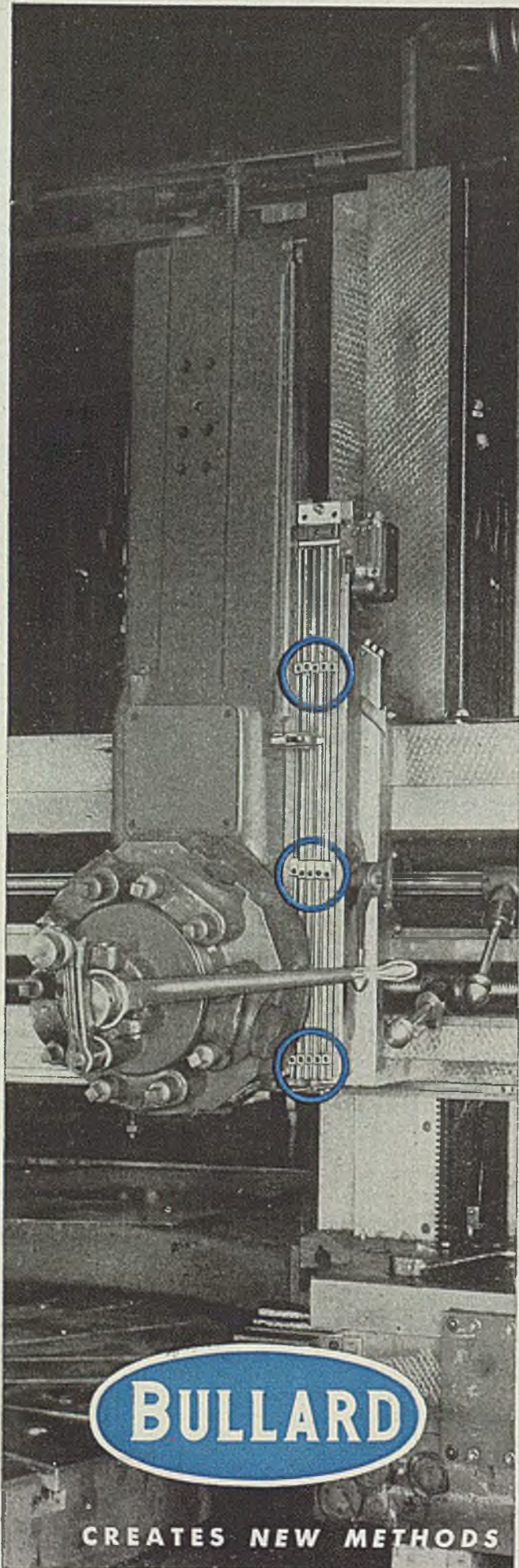

Bullard Cut Master Vertical Turret Lathes are available in 30" and 36" sizes with two heads... in 42", 54", 64" and 74" sizes with two or three heads.

BULLARD
CREATES NEW METHODS TO MAKE MACHINES DO MORE

Mirrors of Motordom

Quick changeover to 1947 models indicated for majority of automakers late in December or early in January. New cars will have discernible changes from present ones, but will be substantially same. Important changes may await 1948 models

DETROIT

FIVE years ago passenger car assembly lines were grinding to a stop and the changeover of tools and equipment to 1942 model production was under way in most plants. Nash, Packard and Willys started their new series early in the month. Pig iron was placed under priority Sept. 1. Studebaker and Dodge threw the switches on new lines Aug. 19 and 20, followed in a few days by Chrysler, De Soto and the General Motors Divisions. Ford and Mercury did not get under way until Sept. 10.

With war clouds sweeping toward this country, the outlook for automobiles was not auspicious and by February virtually all production had stopped, after a short five months which probably was some distance away from covering the retooling costs of that prewar summer. True, the tooling involved was not pretentious but it was perhaps of average proportions. Last year, when preparations were being made for a fresh start on passenger cars, most of the 1942 tools were brought out of storage and, supplemented by a little additional jig and fixture work, were readily adapted to 1946 models.

But they were not 1946 models for all producers. Chrysler used no yearly identification at all. General Motors called them 1946 models. Ford hemmed and hawed and finally said the current series would carry through until at least January of 1947. Studebaker ran off a few 1946 models and then this spring switched over to its 6C or 1947 model. Packard said there would be nothing new until next year. The question now is: How will the industry re-establish its normal production pattern and at the same time avoid short runs on high-cost tools?

Right now the pattern is crystallizing about in this fashion: Current models will be pushed to the limit of availability of materials and parts, and the willingness of labor to labor. Meanwhile a number of revisions in styling, requiring only modest expenditures for tooling, jigs and fixtures, will be readied so that a quick changeover to 1947 models can be effected late in December or early in January. The new model will be a sort of interim proposition—discernibly different from this year's models but substantially the same thing. It will have

a production life of around eight months, and by a year from now the first really new and importantly different postwar designs will go into production, as 1948 models.

This policy will not necessarily apply to the entire industry. There will be variations here and there, but it likely will be the plan followed by General Motors, Chrysler and Ford. A scattering of new jig and fixture work already is in progress for General Motors units, and the Briggs tool and die department is hard at work on production tools for some of the 1947 Chrysler stuff—at least it

Automobile Production

Passenger Cars and Trucks—U. S. and Canada

Tabulated by Ward's Automotive Reports

	1946	1941
January	121,861	524,073
February	83,841	509,332
March	140,777	533,878
April	248,318	489,856
May	247,620	545,321
June	214,511*	546,278
July	333,400*	468,897

Estimates for week ended:

July 27	84,720	105,635
Aug. 3	79,385	62,146
Aug. 10	78,597	41,795
Aug. 17	80,000	45,550

*Preliminary.

was until last week when the boys walked out on strike over some fancied grievance. The larger independent tool and die shops around Detroit are fairly busy, but no major programs seem to have been placed, substantiating the belief the changes this winter will be minor in character.

It was beginning to be fairly obvious that 1946 models could not logically be sold in 1947, sellers' market or no, and many sales people are of the opinion that possibly by the end of the year, some real selling will again be necessary to move new cars. Hence the decision for a little more facelifting after the first of the year, which will start cars now being sold on their first year of obsolescence, and will serve to satisfy in greater degree buyers who have waited

until 1947, either willingly or unwillingly, to make new purchases.

New Price Increase for Dealers

The round of price increases O.K.'d by the OPA last week served to tack another 7.3 per cent onto retail prices, but did not increase manufacturers' take a penny. All the increase went to dealers under terms of the Crawford amendment in price control legislation. It was the fourth increase permitted in 1946 prices and another one of about 3 per cent is slated to follow shortly. Neither of the most recent increases, all of which will go to dealers, sets very well with persons who have bought new cars and who have been pushed around, insulted, ignored and had entire accessory books thrown at them by dealers. Scores of complaints of discourteous and rude treatment by dealers have been reported to manufacturers by buyers, but the makers say they are powerless to do much about it.

Perhaps it is just another reflection of the almost complete lack of courtesy and service in American business these days. Much the same situation holds true, whether you deal with a grocery store, a department store, an airline or an automobile dealer.

At any rate, the following tabulation shows adjusted ceiling prices compared with 1942 prices on a number of four-door sedans. Quoted prices do not include taxes, transportation, handling or delivery charges which may average another \$125:

	1946	1942	In-crease	Per Cent
Ford Deluxe	\$1068	800	268	31
Ford Superdeluxe	1134	930	204	22
Chevrolet Fleetmaster	1076	848	228	27
Chevrolet Stylemaster	1005	793	212	27
Lincoln Model 73	2041	1941	100	5
Nash 600	1206	971	235	24
Nash Ambassador	1366	1144	222	19
Chrysler Saratoga	1757	1395	362	26
Chrysler New Yorker	1841	1465	376	26

Studebaker Explains Low Output

Purchasing department officials at Studebaker recently compiled for the edification of Walter Reuther of UAW-CIO a 12-month "Chronology of Despair" explaining why the company had been able to build only 43,011 cars and trucks in the nine months through June 30, against a scheduled program of 134,500. The 1946 Champion model was slated to start last October, with 3000 projected; actually only six pilot jobs were completed due to strikes in plants supplying axles, transmissions, shackles, glass and frames. In November came more strikes interrupting engine bearings, locks

(Material in this department is protected by copyright and its use in any form without permission is prohibited)

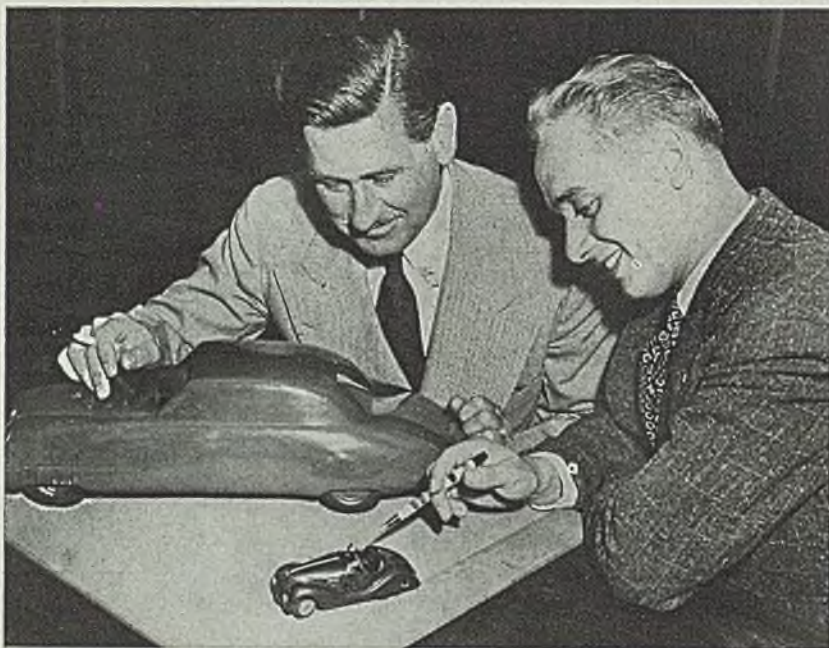

MIDGET MODEL: This model of a German Mercedes-Benz roadster (6 in. long and 2½ in. wide) was picked up in Germany by returning Corp. Irvine Coleman, for two packages of cigarettes. Now an employee of Briggs Mfg. Co., Detroit, the ex-GI here describes the model to A. R. Prance, chief of the Briggs car body design department. The souvenir is powered by a spring-wound motor operating through a flywheel to a small transmission and then to a driveshaft to the right rear wheel. A small gearshift knob near the steering wheel permits shifting through three normal forward speeds and into overdrive, plus reverse and neutral positions. Body is enameled steel and the car is equipped with brakes, steering apparatus, plexiglass windshield and rubber tires with treads. The larger wood model at the rear may suggest body lines now being considered by automotive stylists for 1947 and 1948 models

and keys, fuel pumps, air cleaners and horns, resulting in zero production at South Bend against a schedule of 6000.

By December a start on trucks and passenger cars was possible, but the lack of transmissions held output down to 1309, against a 10,000 schedule. In January things picked up, after a 12-week delay, and assemblies totaled 7506, against a schedule of 7500. By February it was hoped to have the 1946 Champion model out of the way, but only 9048 vehicles were built, with 13,000 scheduled. By March 18, the last of the 5C Champion model was built, and settlement of the General Motors strike improved the outlook. However, a rash of new strikes in plants furnishing cushion springs, rubber parts, steering gears, bolts and nuts, hose clamps and truck axles threw assemblies into another tailspin, schedules for April being 25,000, production 3026.

In May the 1947 Champion model was started after a delay of 11 weeks, but a power line break, slowdown in bumper production, strike in piston ring plant and shortage resulting from coal and rail-

road strikes held assemblies down to 4570, against a planned 25,000. All production stopped May 27, but was able to limp ahead by June 3, although only 9694 cars and trucks were built that month, when schedules called for another 25,000.

It should be remembered Studebaker enjoys cordial relations with its UAW-CIO employees and during this hectic period had no strikes in its own plants. Nevertheless its employees lost 15,000-000 man-hours of work and better than \$20 million in wages through no fault of theirs. Fresh strikes last month cut off supplies of body hardware, wheel rims, ignition equipment, rubber parts and leather, forcing the plant to close again July 30 for a few days.

GM To Build New Foundry

Central foundry division of General Motors will build for operation by next April a large new gray iron foundry to supply short-run castings requirements of various divisions which are unable to locate outside sources for such parts. Tentative selection and optioning of sites

in both Defiance and Tiffin, O., was made, but final choice of a plant city was considered to be a question of available labor supply, so the corporation went directly to the residents of these two cities and, through newspaper advertisements asked how many persons would be interested in employment at the proposed new plant. Representatives of the foundry division set up headquarters in both cities last week and were interviewing applicants. Employment needs total 2000, with 800 for molding, sand testing, melting and pouring operations, 700 for producing, assembling and gaging cores, and 500 for cleaning, grinding and inspection work. Whichever city produced the largest number of applicants was destined to be chosen for the new plant, but S. W. Healy, general manager, pointed out that if he could not recruit from either community a working force sufficient to operate the foundry, he would have no alternative but to drop options at both locations and seek a site elsewhere.

Shortage of housing materials for new construction and the lack of facilities to accommodate in-migrant workers, convinced GM it should try this new technique of recruiting a working force from present residents of the plant city. The foundry building itself, now fairly well along in design, will feature the latest in mechanical equipment for handling of molds and pouring of iron, and there has even been discussion of a building design embodying steel and glass walls which could be completely raised from ground level to improve ventilation.

Ford To Decentralize Buying

Program to decentralize a part of the \$600 million purchasing operations of Ford Motor Co., making possible a \$10 million annual increase in "at home" buying in branch assembly plants, has been instituted. Under its provisions, purchasing agents in 13 Ford assembly plants will be authorized to buy directly in their local communities to fill needs for maintenance, repairs and general stores items. They are:—G. A. Munger at Buffalo; G. A. Lewe at Chester, Pa.; A. R. Reich at Chicago; J. R. Phipps at Dallas; Fred Schumann at Edgewater, N. J.; F. C. Brickey at Kansas City, Mo.; R. W. Anderson at Long Beach, Calif.; V. H. Hulette at Louisville, Ky.; C. B. Gadd at Memphis; G. A. Ringer at Norfolk, Va.; Otto Stahmer at Richmond, Calif.; W. A. Burnham at Somerville, Mass.; and R. J. Mallone at St. Paul.

Harold W. White, formerly active with engine testing laboratories at Studebaker and Oldsmobile, has been appointed head of engine research for Ford.

VERSATILITY that Exactly meets
your needs in MACHINE TOOLS



ANY FEED RATE



ANY TRAVERSE RATE



ANY RPM



ANY SEQUENCE
OF MOTIONS



ANY ACCELERATION
OR DECELERATION



ANY THRUST



Machine tool design is set free from a host of limitations when Vickers Hydraulic Controls and Drives are used. With no difficulty at all, the designer has an extremely wide choice of feed rates, traverse rates, RPM, sequence of motions, accelerations or decelerations, and thrusts.

Practically any machine tool can be designed and built to do exactly the required job by using Vickers Hydromotive Controls in one of the infinite number of combinations provided by more than 5000 standard Vickers Units.

In addition, positive overload limitations can be built into any machine—definite safety factors provided for both the machine and the operator.

Only Vickers Hydraulic Controls provide *all* the advantages of hydraulic operation—including exceptional compactness and reliability.

Let Vickers Application Engineers consult with you on your new designs.

VICKERS Incorporated

1489 OAKMAN BLVD. • DETROIT 52, MICHIGAN
Application Engineering Offices: Chicago • Cincinnati • Cleveland
Detroit • Los Angeles • Newark • Philadelphia • Rochester • Rockford
Tulsa • Worcester

VICKERS Hydraulic
CONTROLS and DRIVES

ENGINEERS AND BUILDERS OF OIL HYDRAULIC EQUIPMENT SINCE 1921

Launch Efforts To Obtain Lower East-Bound Rate

California manufacturers charge inequalities prevent shipment of western made products to eastern states

SAN FRANCISCO

CALIFORNIA Manufacturers Association has started a campaign to balance inequalities in east-west rail rates to remove what the association calls an "iron curtain" standing in the way of shipment of western made products to the eastern part of the U. S.

The manufacturers group reports that 700 to 800 less-than-carload railroad rates are higher on eastbound traffic than on westbound. In an effort to change this situation an application has been filed and is now pending before the Transcontinental Freight Bureau for reductions which will save \$1.07 per 100 pounds on shipments from California to Chicago.

The association states that both truck lines and intercoastal steamship lines charge the same rates for both eastbound and westbound shipments, and it is held that the association's petition, if approved, will achieve parity in most cases on the railroads.

A number of examples are cited by the association of the present disparity which works against western manufacturers in competition with eastern goods in eastern markets. For instance, eastbound I.c.l. rates on California-made washing machines are \$3.74 per 100 pounds compared with a westbound rate of \$2.86.

San Francisco Gains in Import-Export Trade

SAN FRANCISCO

The San Francisco-Oakland customs district in April led the West Coast's ports in volume of exports and imports.

Exports for the month were valued at \$18,304,000, or 36 per cent total shipments from the five West Coast customs districts. At the same time, imports through the San Francisco-Oakland port totaled \$8,070,000.

A considerable volume of traffic through West Coast ports still is for military purposes. However, as industrial production on the West Coast and throughout the country as a whole increases, it is expected that offshore shipments will expand steadily.



EVERETT D. GRAFF

Ryerson Building New Warehouse in California

Joseph T. Ryerson & Son Inc. is constructing a new steel service plant in the Los Angeles district to serve the West Coast area and expects to have the new warehouse in operation by autumn. The unit will be the twelfth in the Ryerson system.

Everett D. Graff, Ryerson president, indicated the new West Coast plant is being built in anticipation of continued growth and expansion of industry in California and other western states in the postwar period.

Ground for the new plant consists of a plot of 8.7 acres fronting on Bandini Boulevard, southeast of the city of Los Angeles. The warehouse building will be made up of seven spans of which two are 600 ft long and the largest 110 ft wide. Total floor space is 200,000 sq ft. Every foot of floor space will be served by cranes.

Oil Well Supply Co. Establishes Branch

SAN FRANCISCO

Oil Well Supply Co., subsidiary of U. S. Steel Corp., has established a branch division sales office in San Francisco. The new office will service increasing activity in foreign oil development by California producers and also will handle the domestic needs of the oil industry in northern California and the San Francisco area. California division headquarters are in Los Angeles.

Steel Supplies Easier; Labor Picture Clearing

Southern California industrialists optimistic over prospects for higher production and better profits

LOS ANGELES

NARROWING of the spread between orders and deliveries on the majority of steel shapes to fabricators is noted in this area. Each week the picture is brightening, a fact borne out numerically in figures for June and July, a press survey of the field disclosed last week.

Merchant mill items with few exceptions, are being received by manufacturers long hard-pressed for materials and although the shortage is by no means solved, optimism is rising that this phase of reconversion woes are receding.

Sheets are not yet readily obtainable, however, nor has mill production caught up with demand for some badly needed materials in construction work, such as nails and reinforcing steel.

All this is backed by the floodtide of corporate reports that show expanded activities both in production and earnings. In general, southern California manufacturers feel that there is good prospect for industrial peace in the months ahead and this lends credence to belief that the uptrend will carry through to the end of the year.

Heavy Industries Show Improvement

The improvement applies strongly to companies in heavy durable goods and durable consumers' goods production. In other classifications of manufacture the same trend is apparent but not as pronounced.

Reinstatement of OPA at first induced fears of many businessmen that hopeless confusion would further impede readjustments and industrial advance. This has proved to be more chimera than fact. The actual pattern is much brighter. Despite lack of worker housing, despite complaints that many unskilled and some skilled workers were refusing jobs in favor of a life of ease on unemployment insurance rolls, industries in the main, in southern California, have built production forces sufficient to cope with unfolding production problems.

Early fears that the area was attracting a plethora of inferior types from the hinterlands and that these, temporarily nourished on the wave of the wartime

prosperity, would presently revert to type when the easy money days were over, have been reconciled to some extent. This single phase of the picture may or may not have been explained by one Los Angeles industrialist who said:

"Modern industry is founded on machine production. It is a concomitance of such production that machine tenders must have certain qualities of mind and character to become and remain useful to the company employing them and hence to themselves and their families.

"Given these qualities, degrees of education or intellect have little bearing on the performance of the job itself. The proper psychology is the important factor, a psychology that encompasses justice to both employer and employee. Give me a worker who is a little selfish, so that he will guard his own future and it matters little what school he attended or what part of the country he came from."

Dulien Steel Products Co. Will Expand Operations

PORTLAND, OREG.

Dulien Steel Products Inc., Portland, Oreg., has purchased ten acres of in-

dustrial property there as one of the first steps in a coastwise expansion program.

The site is along the main line of Guilds Lake district and will be used for yard operation. The acquisition will facilitate movement of materials.

L. A. Young Plant Reopens After Strike

LOS ANGELES

The L. A. Young Spring & Wire Corp., Los Angeles plant, shut down by CIO strike since last April, reopened this week after management and union agreed on a contract renewal. The strike slowed automobile assembly activities in southern California when plants were unable to get springs and other vital parts during the 300-man walkoff.

Hanford Plant Continues At Capacity Operations

SEATTLE

Army officials announce the manufacture of plutonium for atomic bombs and energy is continuing at the government-owned plant at Hanford, Wash.,

at war peak levels. Increased process knowledge has made it possible to reduce personnel from 6000 to 5000. Col. F. J. Clarke, area engineer, states that the plant is operating at "the same capacity, same production and same security as a year ago." Du Pont on Sept. 1 will hand over the responsibility for operation of the Hanford plant to General Electric Co. which plans an extensive research program on applying atomic energy to peacetime uses.

Geneva Steel Plant Increasing Operations

SAN FRANCISCO

Geneva steel mill in Utah now has in operation all types of units at the plant excepting the structural mill for the first time since resumption of activity by U. S. Steel Corp. Two of three blast furnaces are working, and two of four coke oven batteries are in production. Also in operation are three of nine open hearth furnaces, the slabbing mill and plate mill.

Slightly more than 2000 men are at work in the plant, at the coal mine at Horse Canyon and at the limestone and dolomite quarry at Payson.

Dry Dock, with 6000-Ton Lifting Capacity, Launched on Inland River

FLOATING dry dock with 6000 tons lifting capacity and designed to service ships of tender and Liberty ship class was launched recently by Dravo Corp. at its Neville Island yards at Pittsburgh. It is claimed to be the largest hull ever constructed on an American inland river.

The shiplifting giant is 448 ft long, 97 ft wide and 45 ft high. When it is completely outfitted, it will leave the Dravo yards under special tow and be taken 2.00 miles by water through the locks on the Ohio river and down the Mississippi.

To mechanically test the operation of the dry dock before it is sent to sea, dredging has been done in the Ohio river near Rochester, Pa., to provide a depth sufficient to enable submergence tests to be made. While these tests will determine accurately the time required to submerge and emerge, it is believed that the dock can be lowered to receive a vessel in less than 30 minutes and consequently emerge by pumping out its tanks in about two hours.

The dry dock is a self contained unit. It has its own water distillation plant, sanitary disposal facilities, diesel electric generator sets for light and power, and crew quarters that will keep the men comfortable in any climate. Tremendous storage capacity is available for food,

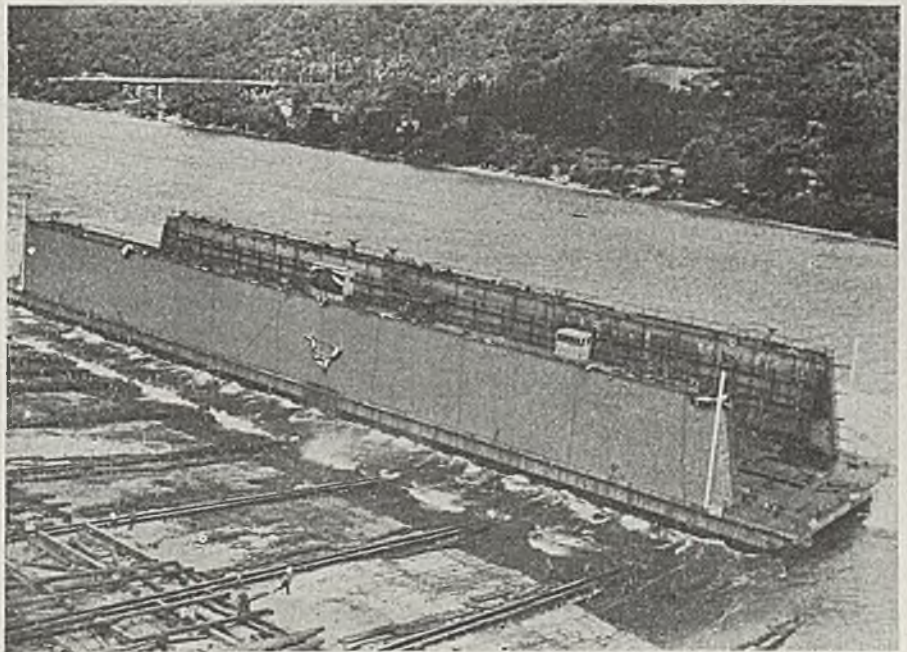

Large ship-lifting dry dock hits the water of the Ohio river at the yards of the Dravo Corp. It is reportedly the largest hull ever built on the inland rivers

repair parts and material, which means the vessel can operate for many months at remote locations with limited supply service.

In erecting the dock, an ARD-33, Dravo used its usual method of fabricat-

ing subassemblies in shop and platen areas and then moved to the ways. Fabricating required the use of more than 73 miles of welding. Welding techniques developed in conjunction with the Navy's Bureau of Yards and Docks were used.

International Detrola Buys Steel Company

All steelmaking, finishing, fabricating and coal mining interests of Andrews Steel Co. of Newport, Ky., acquired

INTERNATIONAL Detrola Corp., Detroit, has purchased all of the steel-making, rolling mill, fabricating plant, and coal mining interests of the Andrews Steel Co., Newport, Ky.

Properties included are those of the Andrews Steel Plant Division in Wilders, Ky.; the Newport Rolling Mill Co. and its divisions, the Globe Iron Roofing & Corrugating Co. and the Newport Culvert Co. in Newport; and the entire Hardy-Burlingham Mining Co. in Perry county, Kentucky. Purchase price was not disclosed.

The Andrews plants in Wilders and Newport, opposite Cincinnati, have more than a million square feet of plant buildings on tracts aggregating 160 acres. The open-hearth division has an annual capacity of 413,100 tons of steel ingots, and the rolling mills have an annual capacity of 180,000 tons of hot-rolled sheets. Of this, 60,000 tons may be silicon sheets, 65,000 tons for galvanized or galvanized sheets, and the balance alloys or miscellaneous grades.

Globe makes corrugated roofing, formed roofing products, eave troughs and conductor pipe, and fabricated building materials.

The Hardy-Burlingham coal mines, with a monthly capacity of 70,000 tons, are producing 55,000 tons of coal, of which about 80 per cent is sold outside, the rest going to the Newport and Wilders plants for steam power and gas producers.

Charles H. Stamm, who was president of Andrews Steel, is to remain as managing executive of the steel company.

International Detrola has ten other plants in the United States and Canada and manufactures home radio receivers and automatic phonographs, refrigerating and air conditioning equipment, radio speakers and cabinets, cedar chests and other special furniture, special production machines and aircraft power plants and subassemblies.

Commenting on the purchase of Andrews Steel Co., C. Russell Feldmann, president of International Detrola, said, "these steel facilities will continue to serve many fabricating and manufacturing interests."



PAYING OFF: As full payment for plants at Duquesne, Homestead and Braddock, Pa., built by the government during the war at a cost of \$120 million, Max D. Howell, left, vice president and treasurer, United States Steel Corp., presents Brig. Gen. John J. O'Brien, deputy War Assets Administrator, with a check for \$65,013,200. Merrill Russell, secretary of Geneva Steel Co., whose plant the corporation also has bought from the government, is shown at right. NEA photo

BRIEFS

Paragraph mentions of developments of interest and significance within the metalworking industry

The American Alloy Foundry, 112 South Eden Street, Baltimore, has acquired an adjacent building and is remodeling it for its own use.

Treet Safety Razor Co., Brooklyn, N. Y., has introduced a double edge razor blade.

General Electric Co., Schenectady, N. Y., has started production in its new \$5 million plastics laminating plant at Coshocton, O. The new plant replaces present GE facilities for manufacture of laminated materials at Lynn, Mass.

Anchor Post Products Inc., 6500 Eastern Avenue, Baltimore, has acquired and is equipping buildings at 139-155 North Haven Street, Baltimore, for manufacture of heaters.

University of Iowa, Iowa City, Iowa, will conduct a short course in "Quality Control by Statistical Methods," Oct. 15-25 for representatives of industry.

The Bassick Co., Bridgeport, Conn.,

a division of Stewart-Warner Corp., Chicago, has purchased at Bridgeport an eight-acre tract containing 11 buildings and plans to construct additional buildings to provide sufficient manufacturing space. The buildings formerly were occupied by Vought-Sikorsky Division of United Aircraft Corp.

Barium Steel Corp., New York, has acquired 100 per cent control of Wiley Equipment Co., Port Deposit, Md., and Wiley Mfg. Co., Mountville, Pa., manufacturers of cranes, barges, and hoisting and loading equipment.

Paisley Products Inc., Chicago, has purchased the Adhesive Division of Certified Products Co., Chicago.

Crucible Steel Co. of America, New York, has moved its branch offices and facilities in Syracuse, N. Y., to larger quarters in the Larned Bldg., 114 South Warren Street, Postal Zone 2. C. E. O'Connor is branch manager.

Robins Conveyors Inc., Passaic, N. J.

has announced that its Philadelphia office at 12 South 12th St. will be consolidated with offices of Hewitt-Robins Inc., 401 North Broad St., Philadelphia 8, effective Sept. 1.

General Electric Purchases Plant at Fitchburg, Mass.

General Electric Co., Schenectady, N. Y., has purchased the turbine plant it has operated at Fitchburg, Mass. Purchase was made from War Assets Administration for \$2,300,000.

The plant consists of six buildings containing 30,000 sq ft of office space and about 200,000 sq ft of factory area. GE is already spending \$500,000 for expansion of research and production facilities in the plant.

During the war the plant's production facilities were devoted entirely to manufacture of ship service turbine generator sets. In addition to the peacetime production of small turbine generator sets and mechanical drive turbines, the plant will engage in manufacture of nonaircraft turbosuperchargers, gas and diesel arc welders, and high speed arc welders.

New Corporation Purchases Caster and Truck Division

Purchase of the Service Caster & Truck Division from Domestic Industries Inc., Chicago, has been made by a corporation headed by a group of the division's executives.

Service Caster's manufacturing facilities are at Albion, Mich., and Somerville, Mass., and employ 400 people. Executive offices of the new corporation will be located at Albion.

Officers of the new corporation include Edward C. Hamm, president; A. Graham Reid, vice president; L. L. Reed, vice president in charge of manufacturing; and Elmer C. Goodall, secretary and sales manager.

Experimental Refrigerator Car Under Construction

Assembly of an experimental aluminum refrigerator car for Illinois Central Railroad has begun in the carrier's McComb, Miss., car shop.

The car, which is to be built according to plans formulated by the refrigerator car committee of the United Fresh Fruit & Vegetable Association, is to make extensive use of aluminum, fiber glass insulation, and forced air circulation. Through use of collapsible bulkheads the car can be used for ordinary merchandise boxcar purposes and can be heated as well as cooled. The car is expected to

offer temperatures low enough for efficient transportation of deep-freeze foods. Weight of the new car is expected to be 25 per cent less than the usual refrigerator car.

The car is expected to be completed within the next two months, after which extensive tests with various commodities will take place.

Babcock & Wilcox Plant Gets New X-Ray Machine

A two million volt x-ray machine will be installed at the Barberton, O., plant of the Babcock & Wilcox Co., New York, to examine welds in pressure vessels.

Cost of the equipment, together with a special building to be erected, and the installation will be \$150,000. By this purchase, the company, which manu-

factures steam generating equipment, will raise to 12 the number of x-ray machines used at the Barberton plant for examination of pressure vessel welds.

34 Veteran Employees of Ryerson Company Retire

Thirty-four veteran employees of Joseph T. Ryerson & Son Inc., Chicago, have been retired after rolling up a combined total of 1094 years in the steel service business.

During the war, many employees of the company subject to retirement expressed the desire to continue at their jobs in view of the manpower shortage. Consequently, the company temporarily suspended its policy of retiring personnel upon the reaching of retirement age. With the war over, the veterans have retired.

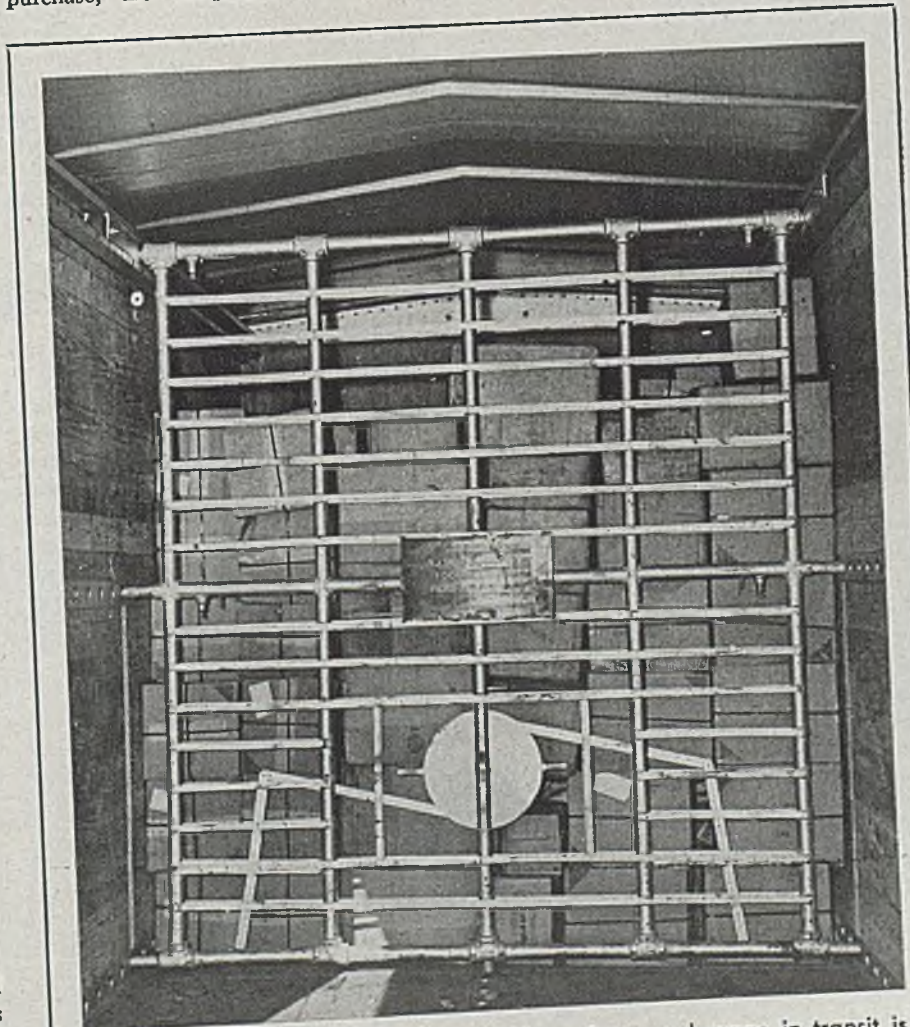

STEEL BULKHEAD: Answer to the problem of cargo damage in transit is believed by the Texas & Pacific Railway Co. executives to have been found in this adjustable steel bulkhead invented by one of its employees. A boxcar or refrigerator car may be partitioned into as many compartments as desired by simply sliding the steel pipe framework along the trackage at the car roof and locking in place against the cargo with cam disk arrangement at lower center. Lever-powered bars lock the bulkhead at the lower corners. Tests have shown the bulkheads prevent cargo shifting and minimize damage in transit

Men of Industry



HARRY L. KELLER

Harry L. Keller has been appointed head of the new commercial engineering department, Tocco Induction Heating Division, Ohio Crankshaft Co., Cleveland. Mr. Keller was automotive production engineer in charge of engineering standards, Buick Motor Co., Flint, Mich. He had been with Buick for 25 years. Dr. Harry B. Osborn Jr., formerly research and development engineer, has been promoted to sales manager of the Tocco Division. John T. Vaughn has succeeded Dr. Osborn as research and development engineer for the division, while A. H. Pitaway has become laboratory superintendent, and John Gibbons, office supervisor.

—o—

George B. Coffey has been appointed manager, Chicago Division, A. M. Byers Co., Pittsburgh, succeeding W. A. Taylor who has resigned to enter other business. The Chicago Division includes the states of Michigan, Minnesota, North and South Dakota, Wisconsin, Iowa, Indiana, and parts of Illinois and northwestern Ohio. Mr. Coffey has been with the company since 1930.

—o—

George E. Law, recently released from the service, has been named to head the new Appleton, Wis., branch sales office, Reliance Electric & Engineering Co., Cleveland. Mr. Law had been representing the company in Minneapolis. M. J. Sandling, who has served Reliance in western Michigan for several years, will head a new office to be opened in Grand Rapids, Mich. He will be assisted by W. F. Cliff, electrical application engineer, who recently joined the Reliance organization. William K. Schlotterbeck, recently released from the service, has rejoined the Philadelphia office as sales engineer. E. H. Koontz, sales engineer,



W. DOUGLAS PETERS

who during the war handled subcontracts in a naval ordnance program for Reliance in Minneapolis, is now with the company's New York office. Other sales engineers recently assigned to the sales offices are: R. L. Custis to New York; D. M. Larson to Minneapolis; A. C. Perrin to Chicago; and Albert Mann to Detroit.

—o—

W. Douglas Peters has been named assistant general sales manager, Foil Division, Reynolds Metals Co., Richmond, Va., in charge of product sales. Mr. Peters has been with Reynolds in various capacities since 1934, except for a two year period in the Navy. In 1942, he became manager of food and medical packaging for the company in Richmond. Since his release from the Navy, he had been assistant general product manager for the company.

—o—

Felix C. Rodgers has been appointed general manager, Fire Division, Cardox Corp., Chicago. H. V. Williamson has been named director of research for the company. For the last several years, Mr. Rodgers had been a district manager for the Fire Division, with headquarters in Pittsburgh. Mr. Williamson was chief engineer of the company's Research Division.

—o—

Warren Stuckey has been appointed chief engineer, Moore Corp., Joliet, Ill. He had been mechanical and combustion engineer, National Enameling & Stamping Co., Milwaukee. He also spent ten years as chief testing engineer, Kankakee, Ill., plant, Florence Stove Co., Gardner, Mass.

—o—

Charles H. Burch, recently released from the Army, has rejoined Curtis



HARRY W. HOLT

Lighting Inc., Chicago, and is now sales representative in the Detroit territory. He joined the company in 1936, as salesman in the Atlanta territory, and was there until 1941, when he enlisted in the Army.

—o—

Harry W. Holt has been promoted to vice president and assistant general manager, Wilson Foundry & Machine Co., Pontiac, Mich. Mr. Holt, who has served as vice president in charge of sales since he joined the company in 1941, will continue the direction of the sales department as well as take on additional responsibilities. Prior to joining Wilson, he was vice president and sales manager for Bohn Aluminum & Brass Corp., Detroit.

—o—

J. J. Prindiville Jr. has been elected president and treasurer, Lapointe Machine Tool Co., Hudson, Mass. Mr. Prindiville had been vice president and general manager for the last 15 years. Edward M. Dowd has been elected vice president in charge of production for the company. Mr. Dowd was assistant general manager of the company for the last year. Joseph P. Crosby has been elected vice president in charge of sales for the Lapointe company. During the war, he was general shop superintendent for the firm.

—o—

L. F. Emigholz has been appointed sales manager of the new Pallet Division, Union Steel Products Co., Albion, Mich. During the war years, Mr. Emigholz was in charge of the company's materials handling basket activity.

—o—

W. H. Walter has been appointed chief mechanical engineer, American Bridge Co., Pittsburgh, succeeding C. G. Baumgartner, who has retired after 41

In Clover . . . *with* BRASS BOLTS

This is a "Milk Factory" . . . producing milk for butter, cheese and other products of the great Food Processing Industry.

"But, come, come," you say, "there are no Brass Bolts in a cow!"

True, of course, but Brass Bolts and Screws are used in many devices which protect her health and protect the quality of her milk and milk products.

Wherever there is danger of rust or corrosion from moisture, acid or alkali, Brass and other non-ferrous or stainless steel products by Harper play an important role.

Harper maintains a stock of more than 4850 different items of Bolts, Nuts, Screws, Washers and others fabricated from Brass, Naval Bronze, Silicon Bronze, Monel Metal and Stainless Steel. These Stocks and Harper's Special Engineering Facilities serve the Food Industries through factory branches and distributors in principal cities.

THE H. M. HARPER COMPANY

2646 Fletcher Street • Chicago 18, Illinois

Branch Offices: New York City, Philadelphia,
Los Angeles, Milwaukee, Cincinnati, Dallas
Representatives in Principal Cities

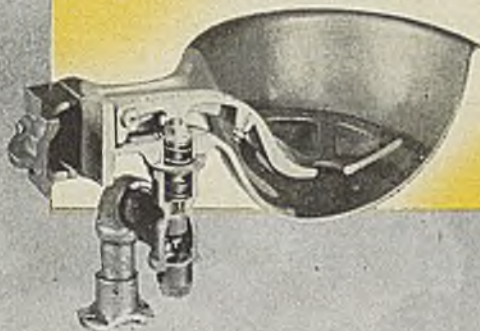

Cast aluminum and brass water bowl by the H. E. Bremer Manufacturing Co. of Milwaukee reduces bacterial breeding packets to a minimum, thus assuring clear, healthful water for the cows. A gentle pressure of the nose on the treadle actuates the water valve. Brass Pins, Bolts, Nuts and Screws by Harper resist rust and corrosion, promote uninterrupted operation.

HARPER

Everlasting Fastenings
Chicago

years with the company. In 1910, Mr. Walter began working during the summer months at the company's Pencoyd plant in Philadelphia. Later he joined the Ambridge plant of American Bridge, where he was assigned to the Heroult electric furnace department in 1917. He was made assistant mechanical engineer of the company in 1937. Mr. Baumgartner had been chief mechanical engineer for the last 14 years.

E. W. Chapman has been appointed chief engineer of the newly created Industrial Pump Division of Bowser Inc., Ft. Wayne, Ind. Mr. Chapman had been chief engineer of Blackmer Pump Co., Grand Rapids, Mich.

Llewellyn Bates Keim has been appointed field electronics engineer, Davenport Co., Newark, N. J. Mr. Keim was associated with Thordarson Electric Mfg. Co., Chicago, and Kyle Corp., Milwaukee, in the capacities of sales engineer and sales manager in the electronics and audio frequency fields.

Leslie C. Hughes has been appointed consulting engineer for the chemical and process industries by H. K. Ferguson Co., Cleveland. Mr. Hughes had been a consulting chemical engineer with Dorr Co. Inc., New York.

Lester A. Lanning, recently appointed manager of the Sandusky plant, New Departure Division, Bristol, Conn., General Motors Corp., now building, has taken up residence in Sandusky, O., to direct completion of the plant, and to take charge of operations when they start. Mr. Lanning has been with the division 27 years, and had been assistant Bristol plant manager since 1939.

John H. Illig has retired as plant superintendent, Barcalo Mfg. Co., Buffalo. He has been succeeded by James E. Burke, formerly assistant superintendent.

Hallis L. Poore has been appointed works manager, Buffalo plant, American Brass Co., Waterbury, Conn. He succeeds Frederick K. Swigert, who has been appointed vice president in charge of the Buffalo branch. Mr. Poore was general foreman of the company's Buffalo copper mill.

Carl O. Ericke has been appointed district manager, Detroit territory, Carpenter Steel Co., Reading, Pa.

Arnold Thomas, for 16 years associated with the metallurgical department of Chrysler Corp., Detroit, and later in

charge of heat treatment at Briggs Mfg. Co., Detroit, has been named to the sales force of Peninsular Steel Co., Detroit, as contact metallurgist in the Michigan territory.

The directors of Malleable Founders' Society, Cleveland, have elected the following to hold office until June, 1947: President, Frank E. Shumann, Lehigh Foundries Inc., Easton, Pa.; vice president, Wilson Moriarty, National Malleable & Steel Castings Co., Cleveland; executive vice president, H. S. Colby, Malleable Founders' Society; and secretary-treasurer, John J. Harant, Malleable Founders' Society.

R. W. Hoyt has been appointed assistant chief engineer, Double Seal Ring Co., Fort Worth, Tex. For 11 years he had been assistant diesel engineer, Scintilla Magneto Division, Sidney, N. Y., Bendix Aviation Corp.

Walter J. Johnston has been appointed assistant treasurer, Nichols Wire & Steel Co., Davenport, Iowa. Mr. Johnston was in the export financial department, New York, Bethlehem Steel Co., Bethlehem, Pa.

A. E. Philips has announced his resignation as vice president in charge of marketing, International Plastic Corp., Morristown, N. J.

E. I. Pollard has been appointed engineering manager, Ridgway Division, Elliott Co., Jeannette, Pa. Mr. Pollard is in charge of electrical engineering for the company, replacing Quintin Graham who was recently appointed assistant manager of the Ridgway Division.

R. E. Wagenhals has been appointed director of quality control for all bearing divisions, Timken Roller Bearing Co.,

Canton, O. Mr. Wagenhals was quality control engineer for the company. He joined Timken in 1943 as a member of the factory engineering staff.

L. W. Boone, for the last 6 years connected with Peden Iron & Steel Co., Houston, Tex., announces his resignation to become associated with Watts Hardware & Supply Co., San Antonio, Tex., as merchandise manager.

Warren W. Burr, recently released from the Navy, has been appointed head of the section on development of protective coating and Pliolite resins of the research staff, Goodyear Tire & Rubber Co., Akron. Stella Alogdelis has been appointed to the Goodyear research staff, and will work in the synthetic rubber research section on development of new and improved polymers. She had been associated with the Akron City Health Department.

Leon Podolsky has been appointed manager of a new field engineering department now being organized by Sprague Electric Co., North Adams, Mass. His new department will be responsible for all company engineering contacts with customers, and will provide any technical assistance required by the sales department. It will also be responsible for the field engineering work of Sprague Products Co., a subsidiary organization with which Mr. Podolsky was previously associated.

R. J. Rice, metallurgical and chemical engineer, has been placed in charge of the new Texas technical section in Houston, Tex., of the Development & Research Division, International Nickel Co., New York. The new section will furnish to industry technical information and assistance relating to alloys containing nickel, and its activities will cover the states of Texas, Oklahoma, Louisiana, Mississippi, and the southern half of Arkansas. Mr. Rice has recently been released from the Navy.

Charles O. Cozzens has been promoted from vice president to president, American Optical Co., Southbridge, Mass., succeeding George B. Wells who will serve as a member of the board of trustees.

Max Riebenack III has been named vice president in charge of sales, Industrial Brownhoist Corp., Bay City, Mich., succeeding James B. Hayden, retired. H. D. Wright has been appointed director of sales for the eastern seaboard, with headquarters in New York. C. H. White has been named director of sales of the south and west portions of the United



E. I. POLLARD

NO MATTER WHAT YOUR PRODUCT MAY BE...

Ex-Cell-O's Complete Parts Production
Facilities May Be of Practical Help to
YOU!

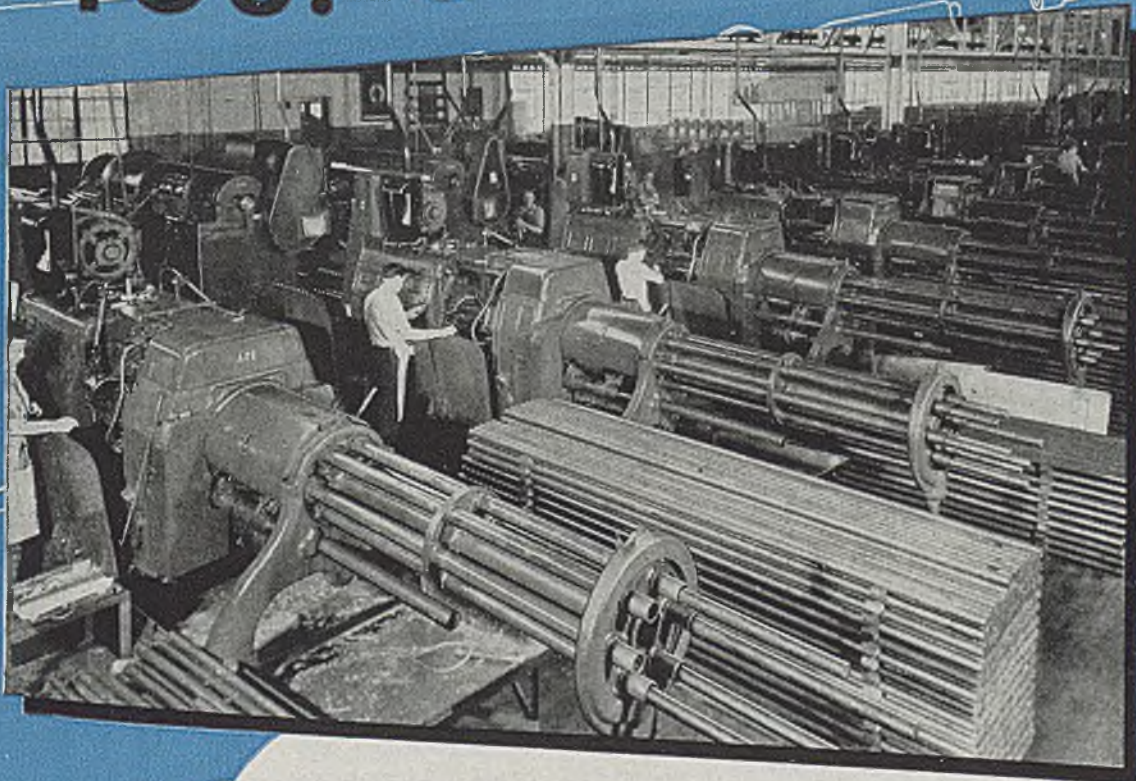

Folder illustrating
Ex-Cell-O's com-
plete parts produc-
tion facilities will be
sent you upon re-
quest. Write or wire
Ex-Cell-O today and
ask for Ex-Cell-O
Bulletin No. 36151.



Few people realize how extensive are Ex-Cell-O's facilities for the speedy production of quality parts. Yet the same wide experience, the engineering "know-how", and the outstanding accuracy that distinguish Ex-Cell-O machine tools and cutting tools wherever they are used . . . in many parts of the world . . . go into Ex-Cell-O's production parts manufacture.

If your product requires carefully machined parts, the chances are Ex-Cell-O can work with you to your economical advantage. Contact Ex-Cell-O today, either at the Head Office in Detroit or through any one of the 27 other leading industrial centers where Ex-Cell-O field engineering representatives are located.

EX-CELL-O CORPORATION • DETROIT 6



EX-CELL-O for PRECISION

States for the company. A. P. Lyvers has been appointed district sales manager of the firm's Chicago office, and Stanley See, district sales manager of the Philadelphia office.

Thomas R. Donoghue has been appointed safety director, Pittsburgh Plate Glass Co., Pittsburgh. He will have jurisdiction over the industrial safety program in the 26 plants operated by the company. He joined the company in 1920, and had been personnel director of the Columbia Chemical Division's Natrium, W. Va., plant since 1942.

Fred A. Lang has been appointed general manager of the new Shoe Products Sales Division, B. F. Goodrich Co., Akron. Mr. Lang has been with the company since 1928, and had been merchandise manager of the Industrial Products Sales Division for the last three years.

Dr. Rufus E. Zimmerman has been elected to receive the Medal for the Advancement of Research for 1946, awarded by the American Society for Metals, Cleveland. Dr. Zimmerman is vice president in charge of research and technology, United States Steel Corp., New York. He is also a director and member of the executive committee of the corporation. Award of the medal, plaque and citation will be made at the annual banquet of the American Society for Metals to be held in Atlantic City, N. J., on Nov. 21, during the National Metal Congress and Exposition.

E. A. Foster has been appointed manager, application engineering department, Railroad Division, Fairbanks, Morse & Co., Chicago. He will have direct responsibility for all locomotive application studies. He was locomotive performance engineer, engineering department, Electro-Motive Division, La Grange, Ill., General Motors Corp. J. F.

Weiffenbach has been appointed chief engineer, Railroad Division, Fairbanks, Morse & Co. He had been doing locomotive engineering and designing for the Electro-Motive Division of General Motors. Frank Ross Jr. has been appointed sales engineer in charge of locomotive sales for the Railroad Division of Fairbanks, Morse & Co. He had been assistant in the division for the last year. Frank M. Bozart has been appointed eastern manager of sales for the company, and will be located in the New York branch. Robert Aldag Jr. has been appointed sales engineer in the Chicago district. Mr. Bozart was with the Electro-Motive Division of General Motors. Mr. Aldag was with the Chicago, Burlington & Quincy Railroad Co.

D. E. Fricker, recently released from the Army, has returned to Le Roi Co., Milwaukee, as assistant to the advertising manager. He had been with the company's advertising department before entering the Army.

George H. Greene, assistant chief engineer, Lackawanna, N. Y., plant, Bethlehem Steel Co., Bethlehem, Pa., has been appointed chief engineer of the company's Steelton plant at Steelton, Pa., effective Sept. 1. He joined Bethlehem in 1926, and was assistant chief engineer at Lackawanna since 1940.

S. D. Moxley has been promoted to vice president, American Cast Iron Pipe Co., Birmingham, succeeding C. D. Barr, recently made president. Mr. Moxley had been chief engineer of the company since 1926.

Detroit Broach Co., Detroit, announces appointment of three new sales representatives. Ernest A. Isberg is now serving the Philadelphia, southern New Jersey, Delaware, Maryland, District of Columbia and southeastern Pennsylv-

vania territory. Mr. Isberg was with the engineering section of Westinghouse Electric Corp., Pittsburgh. Sam H. Penny, Houston, Tex., is serving southeastern Texas for the Detroit Broach Co. Henry E. Roedter, Cincinnati, is serving southern Ohio and Kentucky. James W. bb, formerly assistant chief engineer for the company, is now sales engineer. He will be working in co-operation with all Detroit Broach representatives throughout the United States.

Arthur C. Wilby has been elected vice president, United States Steel Corp. of Delaware, New York. Mr. Wilby, who has been associated with United States Steel since 1909, will maintain his headquarters in Chicago. He came to the corporation as a salesman for the subsidiary, Universal Atlas Cement Co., New York. He became assistant to the president of Universal Atlas in 1917. Mr. Wilby was appointed Chicago district manager of public relations, Carnegie-Illinois Steel Corp., Pittsburgh, in 1937. At the same time, and until 1939, he also was in charge of the liquidation of surplus properties belonging to United States Steel subsidiaries. Since 1938, he has been in charge of public relations for United States Steel subsidiaries in the Chicago district.

C. McA. Evans, now on terminal leave after more than 5 years in the Navy, has been elected president, Chicago Steel Foundry Co., Chicago.

Frederick C. Abbott, formerly manager of the New Products Division, has been named assistant production manager, manufacturing department, Pennsylvania Salt Mfg. Co., Philadelphia. He reports to C. S. Beldin, production manager. Hugh Richard Bishop, recently released from the Army, has been named manager of the New Products Division, succeeding Mr. Abbott. Martin E. Johnson has been transferred from the market research department to the New Products Division. Mr. Abbott joined Pennsalt in 1943. He is a member of American Chemical Society and American Institute of Chemical Engineers.

Donald L. Hadley has been appointed head of the new Hartford, Conn., firm of Hadley, Ryder & Pederson. He had been design consultant for Westinghouse Electric Corp., Pittsburgh.

Dave Wetherly, chemical engineer who participated in a supervisory capacity during the design and construction program at the Oak Ridge Team-atom bomb plant, has been named con-



DR. RUFUS E. ZIMMERMAN



S. D. MOXLEY



VIRGIL V. GRANT

Who has been elected treasurer, Caterpillar Tractor Co., Peoria, Ill., noted in STEEL, Aug. 12 issue, p. 71.



MARCUS J. AURELIUS

Elected sales vice president, United States Steel Supply Co., Chicago, noted in STEEL, Aug. 12 issue, p. 68.



I. H. LUNDGREN

Appointed assistant chief engineer, Warren, O., district, Republic Steel Corp., Cleveland, noted in STEEL, Aug. 12 issue, p. 70.

tract engineer for the eastern district, H. K. Ferguson Co., Cleveland. Mr. Wetherly joined the Ferguson company last year, and has been engaged in the design of distillery waste disposal plants.

Dr. Edwin Gregory, chief metallurgist, Edgar Allen & Co. Ltd., Sheffield, England, has been elected president of Institution of Engineering Inspection, succeeding Maj. Gen. C. A. Woods.

Douglas C. Lynch has been appointed assistant general manager, Westinghouse Electric International Co., New York. Associated with the company in New York and abroad since 1937, Mr. Lynch recently returned from a Westinghouse mission to the Near East, where he was in charge of an airport survey in Turkey and conducted other company business in Egypt. Mr. Lynch had been manager of the company's special products department since 1943, and will be succeeded in this position by Robert Russell, formerly assistant man-

ager of the department. Mr. Russell joined the Westinghouse Electric Corp. at its Mansfield, O., plant in 1933, and transferred to the International company at New York in 1935.

O. F. Hans has been elected commercial vice president, General Electric Co., Schenectady, N. Y. He will make his headquarters in Philadelphia, and will be in charge of the company's Atlantic district. Mr. Hans succeeds Charles K. West, who has retired. Mr. West served 47 years with the company.

Wilfred H. Roy has been named assistant to the general production manager, Rheem Mfg. Co., New York. Mr. Roy joined Rheem at the Stockton, Calif., plant in 1942, and recently had been staff assistant at the South Gate plant.

B. A. Chapman, staff engineer, Nash-Kelvinator Corp., Detroit, has been appointed assistant to the vice president in

charge of manufacturing. He joined Plymouth Division of Chrysler Corp., Detroit, in 1930, and from 1931-36, was in charge of plant layout and equipment design. In 1936, he transferred to the corporation's De Soto Division as plant engineer. He joined Nash in 1937 as plant engineer of its Wisconsin plants.

Fred Bannister, former advertising manager of Fafnir Bearing Co., New Britain, Conn., has been appointed New England representative of *The Iron Age*. He succeeds the late Dwight C. Warren.

W. E. Jones, who has been associated with Diamond Alkali Co., Pittsburgh, for 30 years, and who has been treasurer of the company for the greater part of that time, will resign, effective Sept. 1.

William J. McClung has been named general manager, Bethlehem Pacific Coast Steel Corp. His headquarters will be at the South San Francisco plant of the company.

OBITUARIES...

C. E. Monnier, 56, secretary-treasurer, Eureka Tool & Die Co., Dayton, O., died recently.

Edwin H. Kotcher, 54, president, Ketcher Tool & Engineering Co., Center Line, Mich., died recently in Detroit. In earlier years, he was associated with Citroen Motor Car Co. in France, and Fisher Body Division, General Motors Corp., Detroit.

Harry M. White, 76, secretary-treasurer, American Gear & Mfg. Co., Chicago, died recently in Oak Park, Ill. He was co-founder of the company with

his son, Maurice A. White, president, and was also founder of American Stock Gear Co., Chicago, a division of American Gear & Mfg. Co.

Frank A. Terry, 72, who retired in 1939 after 27 years as Cincinnati branch manager Columbia Tool Steel Co., Chicago Heights, Ill., died recently in Brownsville, Tex.

Ralph J. Phipps, 53, assistant treasurer and Eastern Division credit manager, Carnegie-Illinois Steel Corp., Pittsburgh, a subsidiary of United States Steel Corp., died suddenly from a heart attack, Aug. 11, at his home in Mt. Lebanon, Pa. He was first employed

by United States Steel Corp. as a clerk in the accounting department of American Sheet & Tin Plate Co. at Pittsburgh in 1912. He was transferred to Chicago as assistant credit manager in 1935, and retained that same position when Carnegie-Illinois Steel Corp. was formed in 1936. He returned to Pittsburgh as manager of the Eastern Division in May, 1941, and was named assistant treasurer in September of the following year.

William A. Gresens, 56, secretary-treasurer and a director, Robert W. Hunt Co., Chicago, died recently in that city. He had been associated with the company 35 years.

Properties of LIME

FERRITIC ELECTRODES

By ORVILLE T. BARNETT
Division Engineer, Electrode Division
Metal & Thermit Corp.
New York

New electrode extends field of weldable steels to include high carbon steels, carbon and alloy steel castings, enameling stock, cast iron and others. This first article discussing properties will be followed by one next week relating applications of this electrode

NOW high carbon steels, high sulphur free-machining steels, carbon and alloy steel castings, enameling stock and cast iron may all be welded with lime-ferritic electrodes. Heretofore many of these materials have been considered unweldable by any economical means. However this new electrode type, as yet not classified under American Welding Society—American Society for Testing Materials specification for arc welding electrodes, brings these "difficult-to-weld" metals into the fold of weldable materials.

The unalloyed lime-ferritic electrode is known as type HTS. Essentially the coating is comparable to that found on lime type stainless steel electrodes (see STEEL, March 25, 1946) with certain changes to make it suitable for operation with a low carbon rimmed steel core wire. In addition, alloyed varieties are available where deposits of higher tensile or impact strength are needed. The alloyed types have the following Metal & Thermit Corp. classifications:

M & T Designation	Generic Classification
Type HTS	Carbon steel lime-ferritic or just "lime-ferritic"
Type AWL	Manganese molybdenum lime-ferritic
Type 8015Q	Nickel molybdenum lime-ferritic
Type 7015B	Carbon molybdenum lime-ferritic
Type 2115	Chromium molybdenum lime-ferritic

Of course all steels are weldable. But in order to make this statement true, special welding procedures involving

high preheat temperatures, carefully controlled interpass temperatures, heat treatment immediately after welding and even the use of stainless steel electrodes were mandatory. Since the comparatively recent introduction of practical lime-ferritic electrodes, many of these costly operations became unnecessary. Nor must this electrode be considered a new but untried solution to ticklish welding applications. The record now contains enough successful applications to prove the establishment of a different and worthwhile addition to the family of carbon steel welding electrodes.

Considering first the use of lime-ferritic electrodes for the welding of high carbon steels, it is natural to ask why these new electrodes are less likely to develop cracked joints. The answer is founded on observations as yet unexplained with regard to the mechanism of cracking. Lime-ferritic electrodes have a gaseous atmosphere around the arc composed essentially of carbon dioxide and almost free of hydrogen. Other mild steel electrode atmospheres, such as those produced by E6010, E6011, E6012, E6013, E6020 and E6030 electrodes, contain much hydrogen and carbon monoxide.

Bead welds made on hardenable steels with lime-ferritic electrodes showed a consistent freedom from crack formation in the heat-affected zone while all of the other E60XX electrode types produced cracks at this point. Therefore some observers feel that hydrogen is responsible for "under-bead" cracking in the heat affected zone. The hydrogen passes from the liquid weld metal to the heat affected zone of the parent metal where the crack develops. Since lime-ferritic weld atmospheres contain almost no hydrogen, this theory appears to be a quite reasonable explanation of freedom from cracking. In actual practice, IITS electrodes have been used to weld extremely hardenable high carbon steels without any cracking taking place in the heat affected zone.

High sulphur free-machining steels do not respond very well to welding with ordinary electrodes because sulphur causes "hot shortness" or "red shortness". Furthermore, the sulphur interferes with the interaction between slag and weld metal. Where "hot shortness" is present, the weld metal cracks during cooling. Surface holes and a rough weld contour are defects

(Please turn to Page 128)

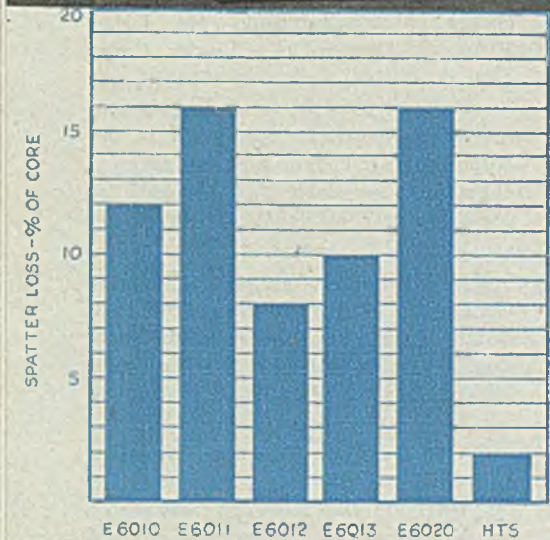

Fig. 1 (left)—Graph showing spatter loss levels common to five types of E60XX and types HTS electrodes

Fig. 2 (above)—Difference in spatter between E6010 electrode (left) and lime-ferritic HTS electrode (right)

TABLE I
OPTIMUM CURRENT RANGES

Electrode Diameter, in.	Amperes	Volts
1/8	90-140	20-23
5/32	125-190	20-23
3/16	155-240	20-24
7/32	230-330	22-26
1/4	275-425	23-27
5/16	350-550	24-30

TABLE II
SPATTER LOSS OF MILD STEEL ELECTRODE TYPES

AWS Grade	(Groove Welds—Flat Position)	Spatter Loss—% of Core
E6010		12
E6011		16
E6012		8
E6013		10
E6020		16
HTS		2

TABLE III
PHYSICAL PROPERTIES OF IITS ELECTRODES
(Welding Done in Accordance with AWS-ASTM A233-45T—As Welded)

Size, in.	1/8 x 14	5/32 x 14	3/16 x 14	7/32 x 14	1/4 x 14	5/16 x 18
Current	Direct	Direct	Direct	Direct	Direct	Direct
Polarity	Reverse	Reverse	Reverse	Reverse	Reverse	Reverse
Amperes	140	162	180	260	338	406
Volts	24.6	23.1	22.7	23.0	24.0	25.5
Yield Strength, psi	60,000	58,750	58,000	58,500	58,000	52,500
Ult. Strength, psi	60,000	58,000	61,500	58,000	58,500	55,000
Elongation, % in 2 in.	76,000	67,500	69,000	64,000	68,000	64,500
Reduction of Area, %	76,000	67,500	69,500	66,500	66,000	33.2
	34.4*	30.5	32.1	33.6	30.5	33.2
	26.6*	29.7	31.3	34.4	35.2	34.3
	70.7	74.5	74.2	71.2	69.0	74.1
	51.6	68.6	72.8	74.5	71.8	

* 1/8" diameter—Elongation, % in 1".

TABLE IV
EFFECT OF STRESS RELIEVING ON PHYSICAL PROPERTIES

	As Welded	Stress Relieved
Size	5/32 x 14	5/32 x 14
Yield Strength, psi	61,000	52,800
Ultimate Strength, psi	67,500	62,750
Elongation, % in 2"	30.1	37.5
Reduction of Area, %	71.5	77.1

Note: Results of two 0.505 specimens averaged.

TABLE V
COMPARATIVE DEPOSITION CHARACTERISTICS AND AS WELDED PHYSICAL PROPERTIES OF E6010, IITS AND E6029 ELECTRODES

	E6010	IITS	E6029
Size	3/16 x 14	3/16 x 14	3/16 x 18
Current	Direct	Direct	Direct
Polarity	Reverse	Reverse	Reverse
Amperes	175	180	225
Volts	20.9	22.7	31.0
DEPOSITION CHARACTERISTICS			
Deposition Rate, Oz./Hr.	57.7	62.2	71.1
Deposition Efficiency, %	79.6	73.1	64.9
Spatter Loss, % of Core	11.5	1.8	14.9
Burn-off Rate, In./Min.	8.7	8.2	11.1
PHYSICAL PROPERTIES			
Yield Strength, psi	52,750	59,750	54,550
Ultimate Strength, psi	65,750	69,250	66,650
Elongation, % in 2"	28.1	31.7	27.7
Reduction of Area, %	55.6	73.5	55.1

Note: Results of two 0.505's averaged.

TABLE VI
CHEMICAL ANALYSES OF IITS WELD METAL
(Five Layer Pad on Mild Steel)

Carbon	Manganese	Phosphorus	Sulphur	Silicon
0.02-0.10	0.50-0.60	0.020 Max.	0.030 Max.	0.20-0.30

HEAT TREATING

Aluminum

This first article in a series of five, discusses the metallurgy and heat treatment of aluminum alloys in nontechnical terms. Techniques that provide desired properties will be described in later articles

By G. W. BIRDSALL
Reynolds Metals Co.
Louisville, Ky.

METALLURGY is an exceedingly complex subject, because the metal structures involved are themselves quite complex. Where electricity lends itself to simple analogies (electricity flowing in a wire being similar to water flowing in a pipe, etc.), there are very few such analogies that can be used in explaining physical metallurgy and metallurgical reactions. However, if we disregard for the moment some of the finer technical details, it is possible to present a few comparatively simple concepts that may enable the reader to obtain a little better understanding of what goes on in producing and heat treating aluminum alloys. Production is included with heat treatment because the two are so closely allied. The following discussion is intended for the nontechnical reader to enable him to more easily understand some of the "reasons why" in metallurgy and heat treatment of the aluminum alloys.

Combinations of metals such as those found in the aluminum alloys may have an exceedingly complex structure. A molten aluminum alloy will be composed of six to nine different metals, some dissolved in others (like ink in water) and some not dissolved but just mixed (like oil in water). As the molten alloy is allowed to cool, it will reach a point where solidification begins. At this point "crystals" begin to form. With continued cooling, additional crystals form, building up on the first ones, in turn producing "grains." Thus for our purpose we will say that the solidified metal is composed of grains, in turn composed of crystals.

In addition, certain compounds are formed by the various combinations of metals. These compounds may solidify out separately, either between the grains along

the grain boundaries, or in the grains between the crystals. Too, certain other elements may separate out during cooling to room temperature. Obviously, the resulting structure is quite complex, as previously mentioned.

Work Hardening: For the moment, let's disregard some of these additional particles and say that in general, aluminum alloys are composed of "grains", in turn composed of "crystals". Adjoining crystals can "slip" against each other in many different directions; that is, they are said to have many different "slip planes". A metal is called "soft" when its crystals have a "fresh" set of slip planes that have "not been used".

We say "not been used" because application of mechanical force will cause crystals to slip along any given slip plane only a certain amount. When a soft metal is hammered or stretched out or has its dimensions changed mechanically by any other method of applying force at room temperature, the adjoining crystals move along a slip plane. But because only a certain amount of slippage can occur along any one slip plane, the limit of movement on that plane is quickly reached and further working then requires slippage along other planes.

However, the planes along which subsequent slippage then occurs may not be so favorably positioned with respect to the applied force. The result is that the application of the same amount of force as before produces much less change in shape. Or stated another way—to produce the same amount of change in shape, much more force must be applied. As further work is done on the piece, this resistance increases (Please turn to Page 156)

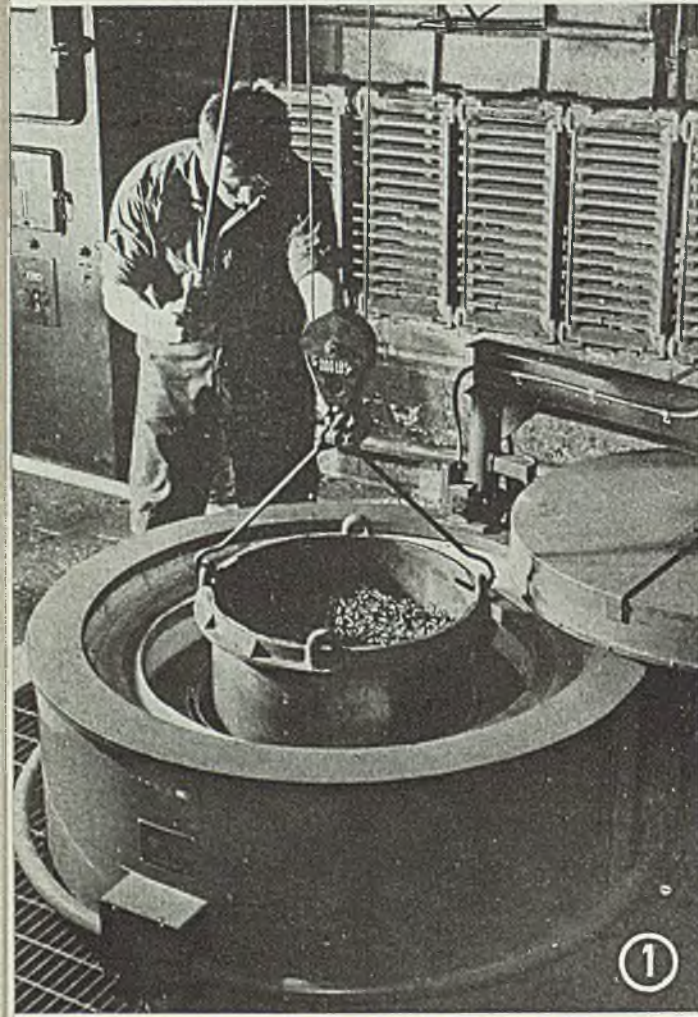

①

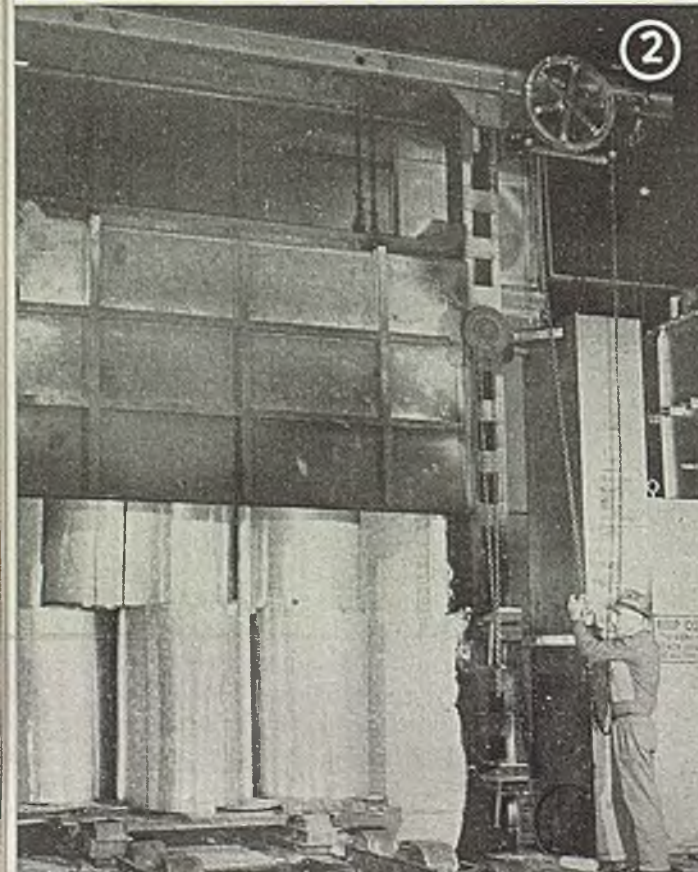

②

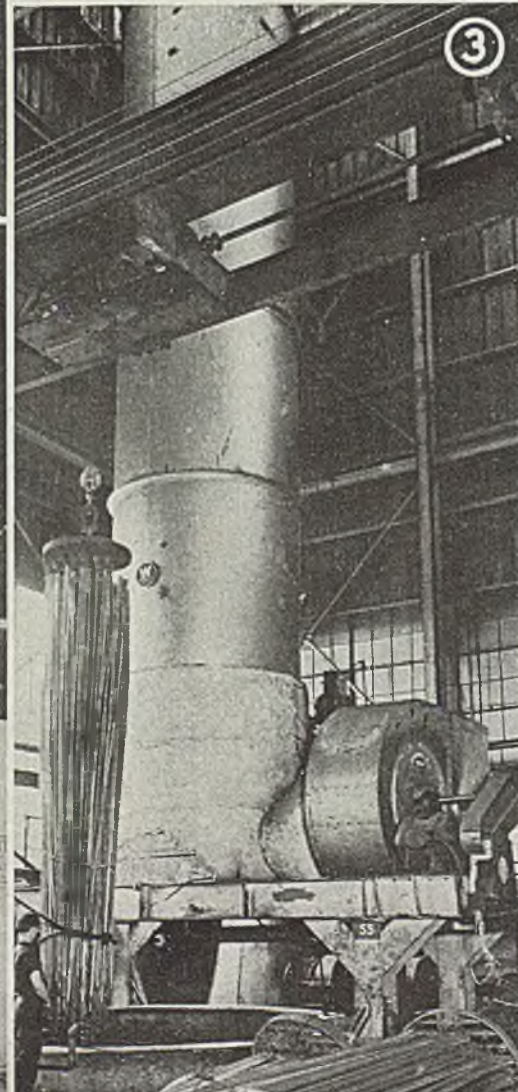

③

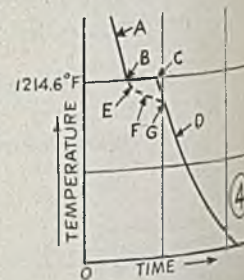
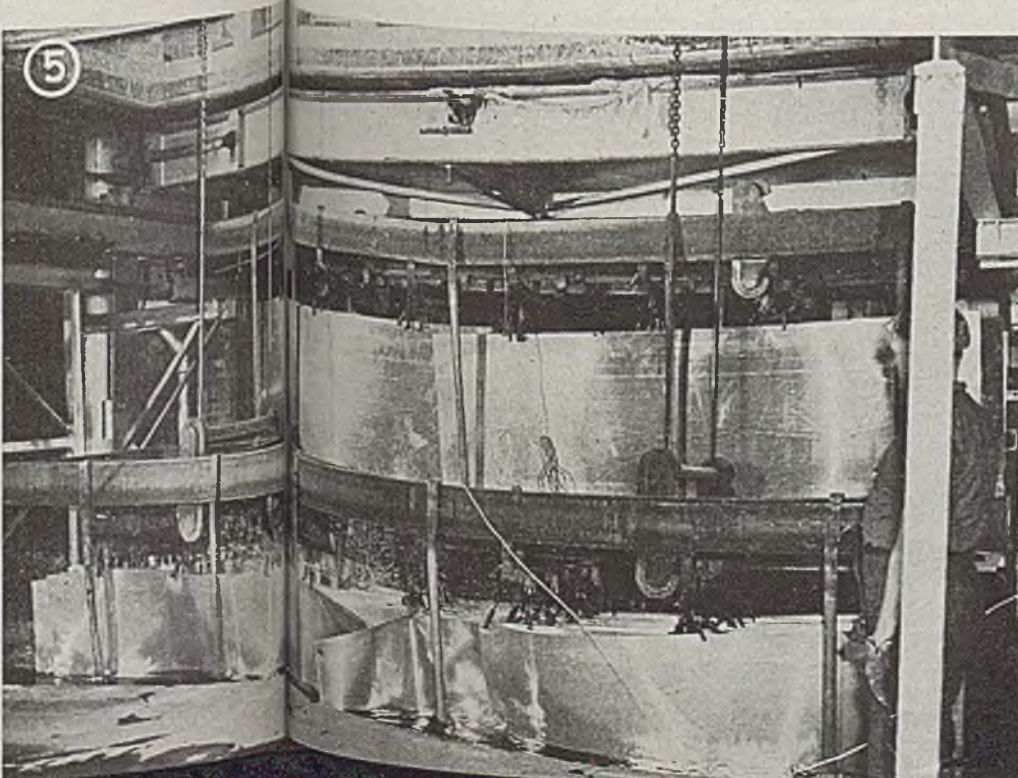

Fig. 1—Furnace for artificial aging (precipitation heat treatment) of aluminum and its alloys. Powerful fan is used to recirculate heated air through load

Fig. 2—Thermocouples both inside and outside of every key coil aid in providing accurate control of heating required for proper heating cycles in heat treating aluminum. Car type furnace being employed

Fig. 3—Special vertical furnace accommodates 50 ft extruded aluminum sections and quenches instantly by dropping them into water pit located directly beneath furnace



⑤

Fig. 4—Chart depicting freezing of pure metals (line A, B, C, and D) and alloys (dotted line E, F, and G). As shown here, a pure metal solidifies at one definite point whereas an alloy does so over a range of temperature

Fig. 5—A fast quench is imperative in many cycles. Here special setup drops sheet directly from furnace into the water quench

Fig. 6—Large refrigerators, using dry ice, cool metal to retard age hardening which otherwise would progress rapidly at room temperatures. Cooling maintains workability, allowing easy straightening or other operations

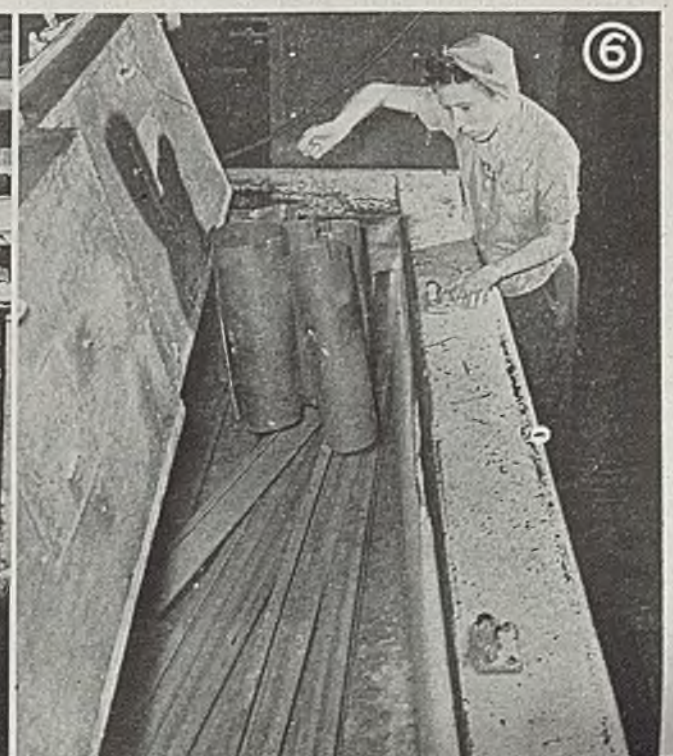

⑥

Reclaiming Brass Scrap

As much as 42,000 pounds of borings and turnings are recovered daily by modern salvaging system

MODERN mechanical handling system for cleaning, separating and recovering brass borings and turnings for use in its own brass foundry was recently installed at the Mt. Clare, Baltimore shops of Baltimore & Ohio railroad.

Most of the staple items such as shoes, wedges and bushings of various sizes are cast at the Mt. Clare foundry principally from scrap borings and turnings originating in the shops of the railroad. Borings and turnings are carefully collected in pans at the place of operation and dumped into skid pans which are then shipped to Mt. Clare in the shop-material express or other cars.

In spite of care exercised to keep ferrous scrap turnings and other matter from becoming mixed with the brass, a small percentage of such foreign material is always present when scrap is received. Obviously it is not suitable for melting into pigs for subsequent use in the brass foundry until such foreign matter has been removed.

Under the old method turnings were dumped into a pile just inside the separator house and shoveled into a vibrating screen designed to eliminate the large pieces and fittings that were mixed with the smaller brass. Turnings were then shoveled by hand into the hopper of a magnetic separator, the brass falling on one side of revolving magnetic drum, and the iron and steel on the other side.

Cleaned brass was shoveled into a large bin in a corner, and the iron and steel into another. As needed, screened and cleaned borings and turnings were shoveled, again by hand, into skid pans and hauled to the foundry.

To replace so much hand shoveling, speed up the operation and cut costs, the department installed three vertical steel-encased, centrifugal-discharge bucket elevators manufactured by Link-Belt Co., Chicago.

Skid pans, containing borings and turnings received from the line of the road, as well as from the local shops, are hauled to the plant by power lift truck and dumped on pile next to bucket elevator No. 1.

As shown in Fig. 1, an attendant (scrap assorter) rakes the scrap to inlet hopper of elevator at floor level, where a screen or grating serves to keep out any material that is larger than the elevators are designed to handle. In addition, a small flat magnet, counterweighted and suspended over inlet hopper from a pulley chain, is utilized for removing any large, heavy pieces of iron and steel.

Bucket elevator No. 1 delivers scrap by circular spout to a revolving screen which further screens out the larger pieces. Brass then passes by gravity to bucket elevator No. 2 which delivers it through a second spout to a magnetic separator, Fig. 2. Here the ferrous metal is removed as it passes over a magnetic revolving drum.

Scrap continues to flow into inlet hopper of No. 3 bucket elevator which raises it for discharge through spout to skid pans that are hauled to the foundry on lift trucks. Scrap is then melted, poured into pigs and held in stock until needed. Separating capacity of this new plant is 42,000 lb daily, or more than a million pounds a month. According to Mr. V. N. Dawson, general storekeeper, of the Baltimore & Ohio system, in his article in *Railway Purchases and Stores* magazine, the new unit is believed to be the most efficient of its kind.

Elevators spaced 7 ft apart, measure 13, 14 and 18 ft centers height. Head shafts of all three elevators are connected by individual roller chain drives to a common drive shaft which in turn is connected to a 5-hp wall mounted double reduction motorized speed reducer of 14 to 1 speed ratio.

Elevating mechanism consists of an endless strand of C-188 malleable iron and steel combination chain to which 6 x 4-in. malleable iron buckets are attached at 13-in. intervals. It is operated at a chain speed of 225 fpm over Flint rim head and foot sprocket wheels. The foot shaft of each elevator operates in take-up bearings which permit adjusting length of elevating medium.

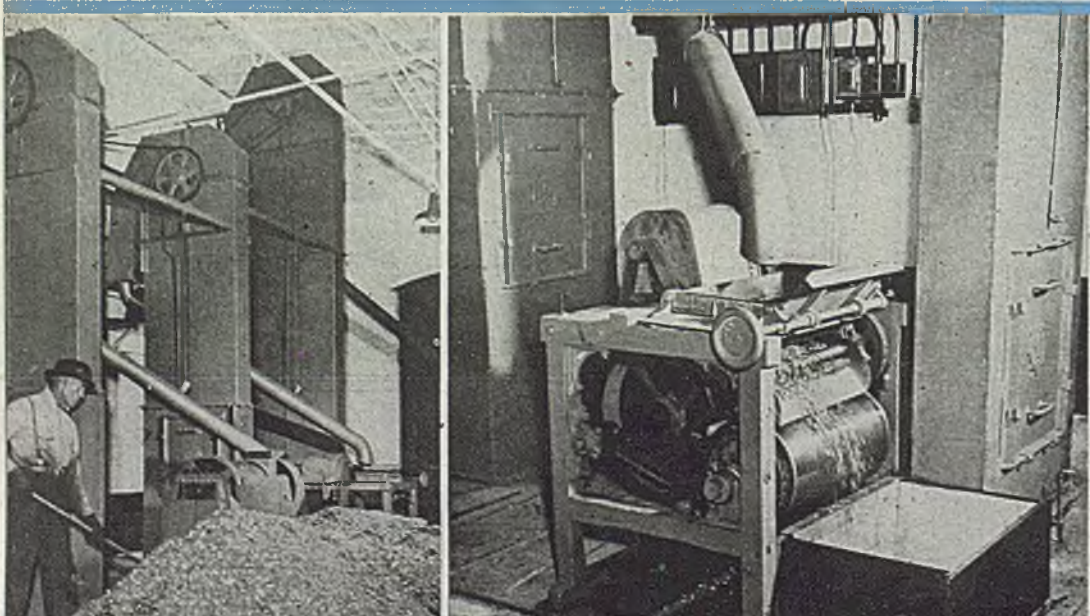

Fig. 1 (left)—General view of scrap separating installation. Pile of metal on floor will be cleaned and recovered for use in the shop foundry

Fig. 2 (right)—In operation of magnetic separator shown here, brass falls off magnetic drum directly into inlet hopper of elevator No. 3. Any remaining iron and steel drops to floor under separator unit. Photos and data courtesy Link-Belt Co.

BRAZING TOOL TIPS

by induction heating

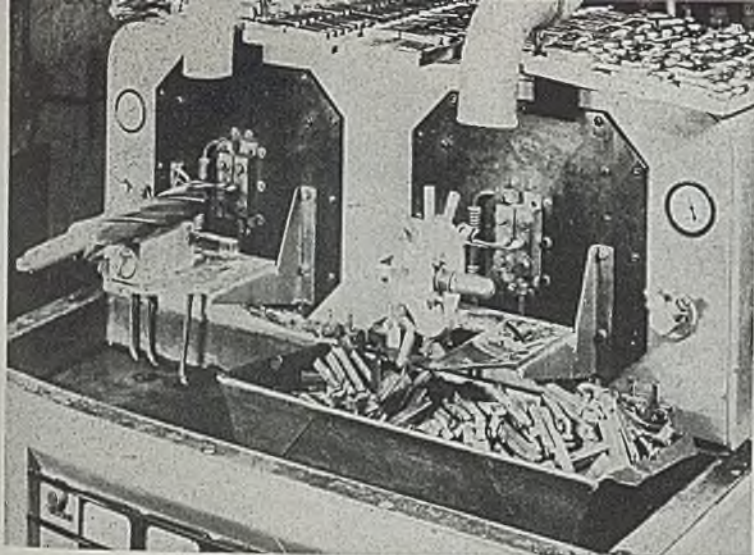

Fig. 1 (above) — Front view of rotary fixture with tools in place for brazing. Tool fixture is changed by removal of only three bolts. Following brazing, tools drop into pan below

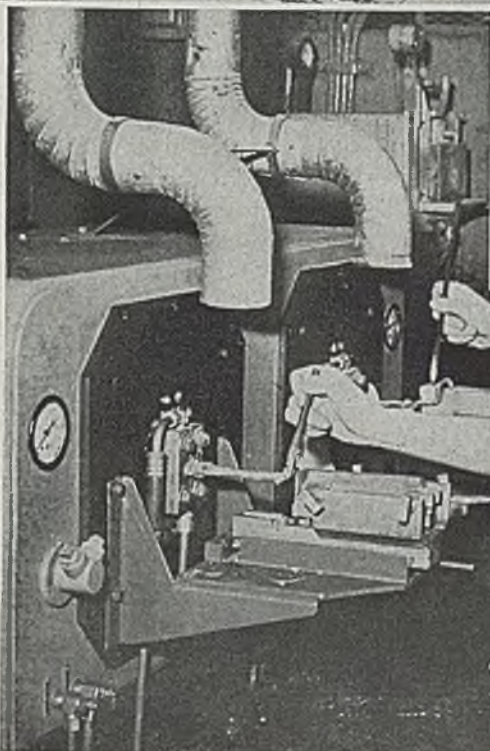

Fig. 2 (right) — In foreground girl operator is brazing a 3/4-in. tool held in a screw clamp fixture. Operator in rear is "wiping" tip into place on a large 1 1/4 x 1 1/2-in. straight shank shell turning tool



Tungsten carbide tips are brazed to more than 200 types of cutting tools by use of induction process; method reduces cost of some jobs from \$4 to 30 cents per hour

ADOPTING induction heating for brazing tungsten carbide tips to more than 200 types of cutting tools effected such savings that a major independent tool producer was able to amortize the cost of his two induction heating machines in three months.

Something of an innovation in the not-too-old practice of brazing tips to cutting tools, this application of induction heating greatly increased output with no increase in manpower. One of the factors responsible for increased production is a rotary fixture developed by the company which enables one operator to do in 1 hour what formerly was achieved in approximately 8.

According to Willey's Carbide Tool Co., Detroit, shipments went up 20 per cent in one month with no increase in manpower by specifying new tools daily for induction brazing. Where certain jobs cost as high as \$4 per hour,

use of induction brazing reduced the cost of the same jobs to as low as 30 cents per hour.

Brazing operations in the plant are performed on two 15 kw, 2-station, 9600 cycle Ohio Crankshaft units using the Tocco process. These are located in the production area of the shop where they provide full-capacity operations.

No complicated technique is required to braze a tip properly to any of the many styles of tools produced in the Willey's plant. The operator, with the tip and brazing material positioned in the recess, places the tool beneath the inductor. The heating cycle may run from 3 sec to 1 min depending upon the type of tool being brazed. As the heating progresses, the operator, by use of a small rod, "wipes" the tip into place as the material softens.

Tools are held beneath the inductor by one of three methods, of which the rotary chuck already mentioned is one. The others are either by a screw-clamp fixture or by a magnetic chuck block. With the latter large tools are easily positioned beneath the inductor in rapid fashion.

The rotary fixture designed in the shops of the Willey's company is a transite block 6 in. in diameter with 1 1/2-in. face mounted on a revolving spindle attached to an upright support. It has a capacity of (Please turn to Page 154)

JOB PLATING *in Volume*

By HERBERT CHASE

Use of holding fixtures wherever possible for buffing and polishing and conveyerized setups for buffing and plating reduces costs and speeds production without sacrificing quality

HIGH efficiency of operation and close adherence to specifications form the cornerstone of Gerity Michigan Die Casting Co.'s modern plating plant. Although the company manufactures lines of bathroom hardware in large quantities, using purchased castings, these items constitute only a fraction of the total plating output. Much of it is on die cast automobile parts which are exposed to severe weathering and require heavy coatings of the highest grade.

Almost the entire output is on zinc alloy die castings that, although cast with remarkably smooth surfaces, require some polishing, especially along parting lines, and buffing on all surfaces to be plated. Polishing is done chiefly on canvas wheels to which grit is glued, or on abrasive belts. Some of these are narrow and run over a pulley at the end of an arm that enables the belt to be passed through openings and reach surfaces (such as the interior of a horn ring) that could not be reached conveniently by a wheel. Although various grades of grit are employed, (usually 180 to 220) policy is to use the finest that will yield desired results.

As in all plating plants, much buffing is done on stitched muslin wheels dressed with stick compounds containing tripoli or equivalent abrasive. On most castings, the irregular shape requires that much if not all buffing be done with the work guided by hand but on some castings handled in large quantities, machine buffing is done. The work is then usually passed under several wheels in succession,

each wheel being set to buff one or more surfaces. Some buffing of circular parts is done on Acme chucks or heads that permit the part to rotate as it is fed against the wheel. Some such heads bring the periphery of one or several castings against the buff and some bring the face of the casting against the wheel.

Some machines used for semiautomatic buffing are of the dial type equipped with holders that rotate the work as the dial advances it under the buffs. In these, used especially for faucet handles, the work is loaded and unloaded at one station while at others around the dial the work is passing under the wheels set to buff specific surfaces. Many wheels are provided with automatic feed of sticks of buffing compound. Parts are completely buffed on exposed surfaces as rapidly as the operator can load and unload the work and lay buffed parts in trays. Some parts, especially faucet handles, have to make two circuits of the dial, being turned over for the second circuit or passed to a second duplicate machine for buffing the second side.

Certain castings, such as flat grille sections and castings of similar shape, are handled on straight line polishing

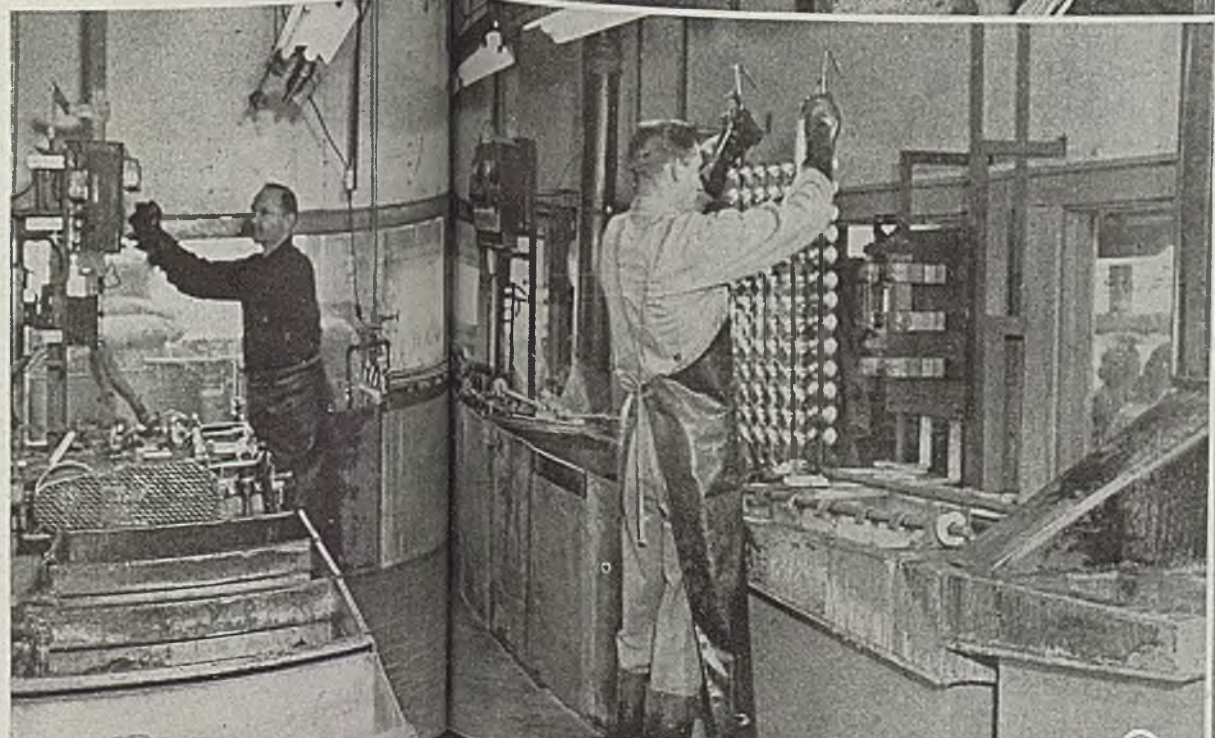
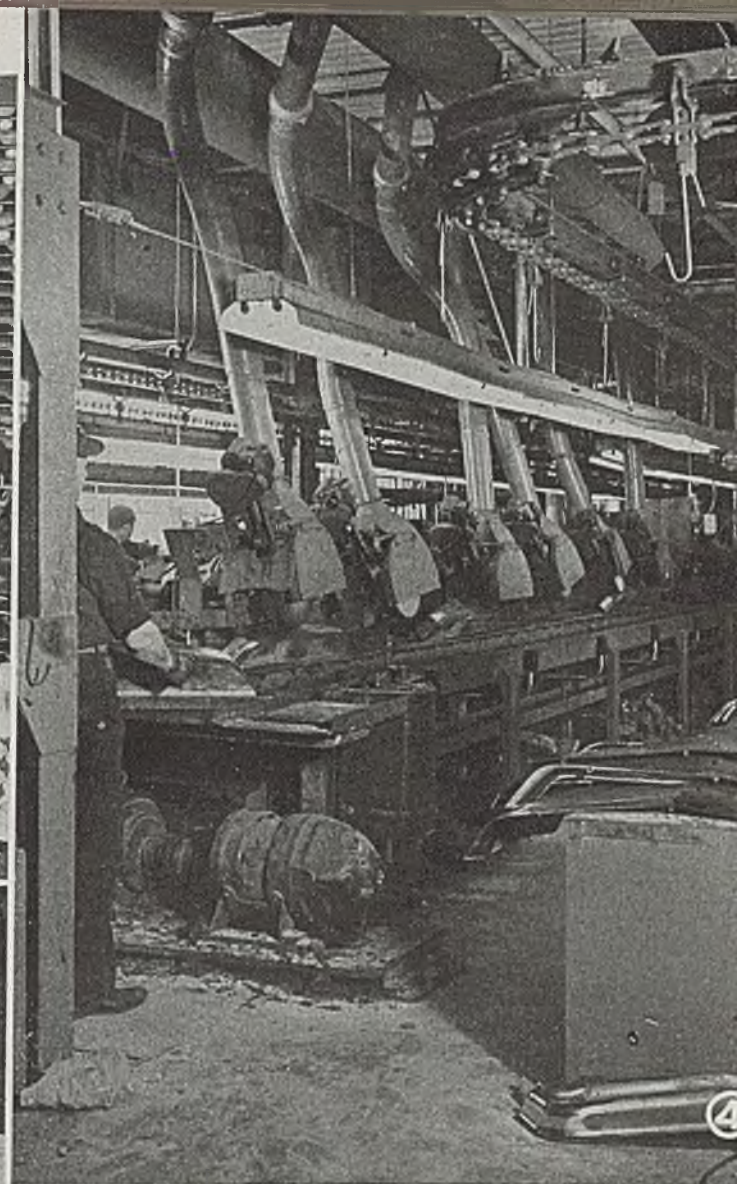

Fig. 1—After color buffing the plated reflectors, they are placed in card racks of this type and are sprayed with clear lacquer to prevent tarnishing

Fig. 2—One of the lines along which hand buffing is done

Fig. 3—Plating setup for handling 20,000 flashlight reflectors per day. Tanks are along three walls of a small room used especially for this work which includes anodic cleaning, copper plating (in tanks at right and far end) and subsequent silver plating in tanks at left

Fig. 4—Straight line machine in which polished castings are placed on fixtures loaded on a conveyor to advance work under six buffing wheels, each set to buff a particular area

Fig. 5—At this station, silver plated reflectors are unracked and laid on the belt (beyond gir.'s hands) along which color-buffing of the plating is done. Wheels, being below belt level, are hidden by partition

machines. The work is placed on wooden holding fixtures that are fed in at one end of the machine and are advanced by a chain along the bed, passing in succession under several wheels, each set to buff a particular surface. At the other end of the machine, the fixtures are unloaded and returned on a conveyor to the loading end. Such automatic machines naturally are faster than hand buffing and require less labor per piece.

Quite unusual but highly efficient is a conveyORIZED setup for buffing and plating 20,000 flashlight reflectors a day. These small castings have the reflector surface cast with extreme smoothness so that only buffing is needed to make the surface ready for plating. At the start of the line, which is along a belt conveyor, the castings are first tapped under a drill press and then are placed on the belt along

each side of which are several operators each having a small power driven buffing wheel that fits inside the reflector.

Each reflector is held on a hand arbor so made that the casting rotates slowly as it is buffed. On the first buff, the portion of the reflector surface next to the rim is buffed and on the second wheel the central or lower portion of the reflector is buffed. This is followed by a final buffing, called "coloring", that provides an exceedingly high luster. Between each operation the small castings are returned to the belt and when they approach the end of the belt they are inspected by girls who also rack the castings for plating. Any defective ones are returned for rebuffing or are rejected, but the proportion of rejects is small.

Because of the large volume of these castings and the fact that they require silver plating, they are handled in a separate plating setup. In the plating line the first operation is to soak in a soap solution and the second is to anodically clean in a proprietary alkaline solution at 190° F. This is followed by a cold rinse, a short dilute acid dip to etch the surface and another cold rinse, making the castings ready for the copper plating that precedes silver plating.

Copper plating is done in two stages, the first being a copper strike applied in a few seconds in a conventional cyanide solution. The purpose of this strike is to prevent immersion plating in the next bath which is of the Uni-chrome high-speed copper type. If immersion coating occurred, the bright copper would lack proper adherence. Bright copper plating requires 4 min at approximately 100 amp per sq ft, the solution being air agitated and held at 130° F.

This bright plating is followed by three cold dip rinses to keep all copper plating solution out of the silver strike bath that follows. After this strike, the racks are shifted

Fig. 6—Conveyor which carries buffed die castings, on hooks or in baskets, through the degreaser, part of which is visible

Fig. 7—Along this line, castings coming from the degreaser are placed on racks by girls wearing gloves to avoid finger and perspiration marks on the piece

Fig. 8—Start of the chrome plating line showing racks of castings hanging from the LaSalco conveyor and about to enter first tank

Fig. 9—Intermediate station on the chrome plating line with one of the spray rinse tanks in the foreground and several racks of castings hanging from conveyor

Fig. 10—One of the conveyORIZED lines for automatic copper and nickel plating. After cleaning and etching, the racks of castings, hanging from the conveyor bars, enter the copper plating tank

Fig. 11—Intermediate station along one plating line where racks leave the copper plating tank, are rinsed and then enter the nickel plating tank by means of automatic conveyor

Fig. 12—Another station on a copper-nickel line showing one of the tanks at which fine high pressure spray rinse is applied

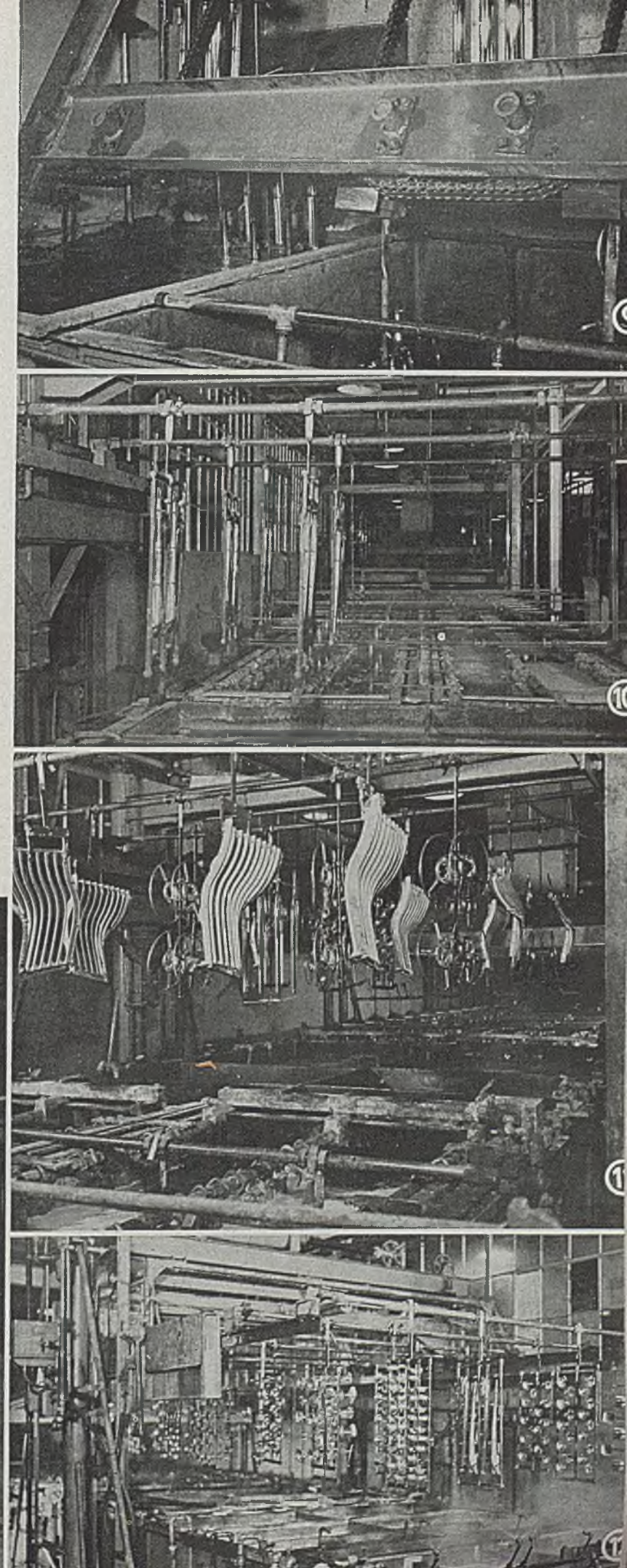
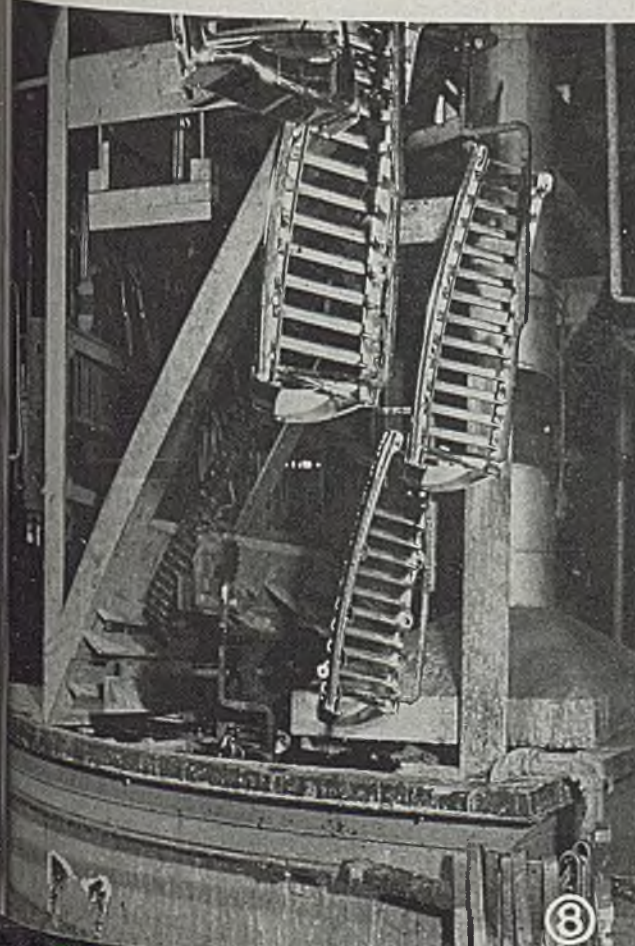
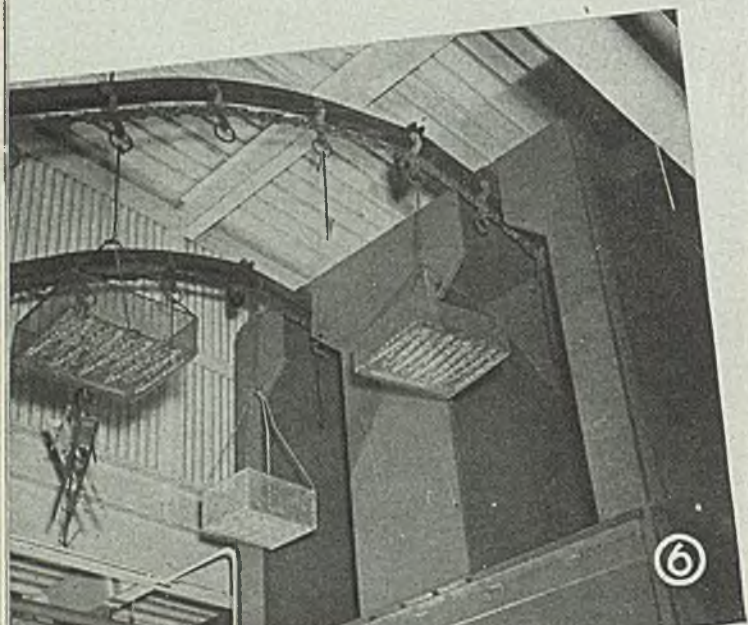

to oscillating bars in the final silver plating solution where plating requires 8 min at 15 amp per sq ft, the bath being at room temperature. Next come three cold dip rinses and a soap rinse, followed by a hot water rinse and blow drying with compressed air. The plated castings are then unracked and placed on a belt conveyor.

Along this conveyor, each plated reflector surface is color buffed, using a silver rouge stick on small soft wheels that yield a brilliant luster. Each reflector is then inspected and one is placed in each hole of a packing card which, when filled, is advanced into a spray booth where a coat of clear lacquer is applied to prevent the silver from tarnishing. Each tray is set aside to dry and is then ready for packing and shipment, completing a highly efficient cycle that yields a beautifully plated part at an exceedingly modest cost.

Other die castings, most of which are far larger parts, follow a quite different cycle along a highly mechanized line. After passing the inspection that follows buffing, large castings are hung from hooks on a monorail chain. Smaller castings are laid in metal baskets that are hung on the same chain which advances them through a standard degreaser. This involves the use of hot trichloethylene applied in four stages, namely: Vapor, liquid spray, vapor and liquid spray. The solvent spray dislodges any solid particles of foreign matter and, in combination with the vapor that condenses on the parts, dissolves all oil and grease, leaving parts clean, dry and ready for racking.

After leaving the degreaser, parts continue on the conveyor along the racking line where they are removed and placed in plating racks, most of which are designed especially for the individual parts. Racks are hung from pipe supports until loaded and then go back on the chain conveyor for transfer to the plating lines. Racking is done with gloved hands, to avoid perspiration and grease marks. Racks are covered with Bunatol stop-off lacquer.

There are three major plating lines. Two of these are mechanized and the third (used chiefly for parts that require either lighter or heavier coatings than are applied on automatic lines) is equipped with ordinary dip tanks. The following applies to the conveyerized lines which,



Fig. 13—Row of spray booths in department where eramel is sprayed on parts of castings most of which already have been plated. One of the masks through which fill-in spraying is done is shown in foreground

Fig. 14—Another part of the enameling room. Girl in background is spraying back face of a grille and those at bench are doing hand touch-up wipe-off work. Spray booths have down draft to draw over-spray away from operators. Part of baking oven is shown in the background and above

Fig. 15—Group of zinc die castings that have been plated with copper-nickel-chromium. Those in foreground are bathroom hardware items and the remainder are automobile grille and trim parts

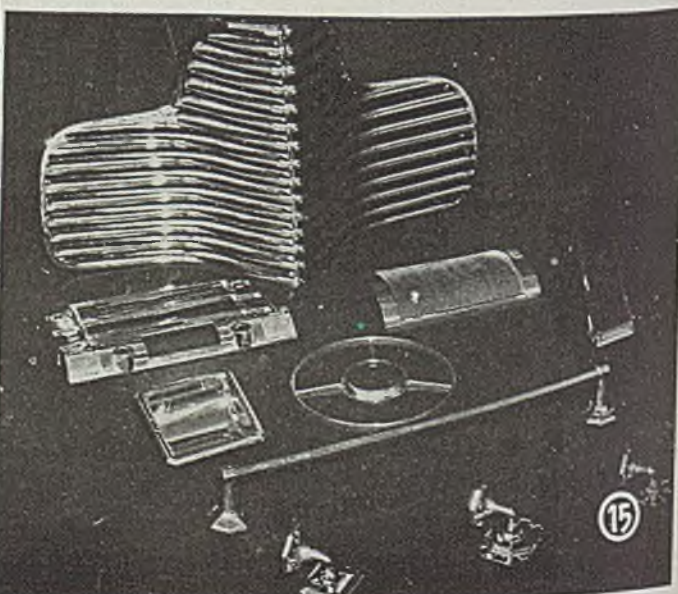

YOU CAN CUT TOOLING COSTS *today*

With This 4-Way Protection Against Tool Steel Failures



O. K.



POROSITY

ACID DISC-INSPECTION — for internal soundness



Tough
Timbre
($\frac{3}{4}$ " rd.)
Both Brine quenched at 1,550° F



Brittle
Timbre
($\frac{3}{4}$ " rd.)

TOUGH TIMBRE TEST — for dependable tool performance

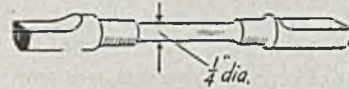

Torsion Impact Test Specimen

TORSION IMPACT TEST — for right combination of toughness and hardness



Cone Test Specimen

CONE TEST — for uniform hardness penetration

On each tooling job, you put all your skill into the making and heat treating of a tool. But, as you know, to prevent costly machine shutdowns and premature tool failure, sound, uniform steels are a "must". That's why these rigid quality tests, pioneered by Carpenter, are your safe bet for lower tooling costs and dependable tool performance.

And Here's Additional Help For Lower Tooling Costs!—
Going one step further in helping you cut costs,

Carpenter gives you a tried and proved method of tool steel selection. For example, the Carpenter Matched Tool Steel Manual quickly points out the steel best suited for each of your tool making jobs. Then it gives you complete heat treating instructions for the steel you select. A note to us on your company letterhead, indicating your title, starts this 168-page Manual on its way to you. Write today.



THE CARPENTER STEEL COMPANY, 139 W. BERN STREET, READING, PA.

Carpenter
MATCHED
TOOL STEELS

SEE YOUR CLASSIFIED TELEPHONE DIRECTORY

Baltimore • Birmingham, Ala. • Boston • Buffalo • Chicago • Cincinnati • Cleveland • Dayton • Detroit • Hartford • Indianapolis • Los Angeles
New York • Philadelphia • Portland, Ore. • Providence • St. Louis • San Francisco • Seattle • Worcester, Mass. Canada: Toronto and Montreal

except for loading and unloading of racks, are entirely automatic and are used for coatings having a total minimum thickness of plate of 0.0008 to 0.001-in.

On the copper-nickel line, a Crown Rheostat Co. conveyor is used and on the chrome line a LaSalco conveyor advances the plating racks. In the first position racks of parts are given a short soak in hot soap solution and then enter the anodic cleaning tank which contains a hot proprietary alkaline cleaner. Next comes a rinse in circulating water after which the bar conveyor shifts the racks into a dilute sulphuric acid to etch the surfaces for ½-min. This is followed by a cold rinse and by short dips in two tanks each of which applies a copper strike from a conventional cyanide solution at 120° F, to prevent immersion plating in the bright copper tank.

After successive cold water rinses, the racks enter the "Unichrome" bright copper bath which is air agitated. In addition, the bars carrying the racks are advanced by chain. Plating continues for 10 min at a 100 am per sq ft current density, the solution being at 130° F. This results in a minimum coat of copper about 0.0003 to 0.0004-in. thick and is followed by both a spray and a dip rinse in cold water, a short dip in dilute sulphuric acid and another water rinse before the racks enter the nickel plating tank.

For nickel plating, a Harshaw bright nickel solution is used, the racks being oscillated vertically while they are advanced the length of the tank in 20 min. The bath is operated at 130° F. Current

density is 45 amp per sq ft yielding a minimum of 0.0005 to 0.0007-in. of nickel. Plating is followed by two cold water dip rinses and the parts are ready for the chrome plating line unless the nickel is not uniformly bright, in which event some buffing is done.

After transfer to the LaSalco conveyor of the chromium plating line, racks first enter a cleaning solution containing sodium cyanide and caustic soda, where the parts remain 15 sec. Three rinses, including spray, dip and spray follow after which the racks enter the chromium sulphate solution for chromium plating about 2 min at a 2 to 4 v potential. Temperature of the bath, which is in a tank lined with vitreous brick, is held automatically at 110° F by a coil through which steam or cold water is circulated. At the end of the tank are nozzles which create a fine water spray that strikes the plated parts as racks are elevated, water draining back into the tank to lower drag-out loss.

Plating Followed By Three Rinses

This plating is followed by three rinses, the first in cold air-agitated water, the second in a cold high pressure spray and third in hot air-agitated water. The latter, of course, warms the work and helps the subsequent drying that follows immediately as the conveyor carries the work through a hot air dryer with forced draft. Racks of work are returned to the loading end of the chrome plating line where they are removed and the parts are unracked and placed on two belt conveyors for inspection.

Most parts thus plated are bright

enough to meet requirements but some require light buffing on certain areas to pass inspection. Castings that are to receive enamel on certain areas are delivered to a paint room for this purpose. There either air-drying lacquer or enamel designed especially for adherence to plated surfaces is sprayed on, usually through a close fitting mask that covers all surfaces except those to be sprayed.

This spraying is done while the work rests on an inclined grating through which there is a down draft to carry off excess spray. Several duplicate masks are provided and, to keep enamel off under surfaces, the masks are hung in solvent as soon as they become soiled enough to deposit enamel on areas where it is not wanted. After spraying, parts are usually baked for 20 min at 280° F while being carried through an oven on a chain conveyor.

Some zinc die castings that do not require plating are also enameled in this department but are first given a coat of zinc chromate primer designed for fast air drying. This primer is said to afford high corrosion resistance and to form an excellent base for the subsequent enamel coat that is baked on in the same oven and for the same time as the enamel applied over plating.

All the operations here described, as well as the solutions used, are subject to exacting control as this is essential, both to provide the high quality of finish desired and to meet customer specifications. By employing mechanized equipment, labor per piece is minimized and costs are kept within required limits.

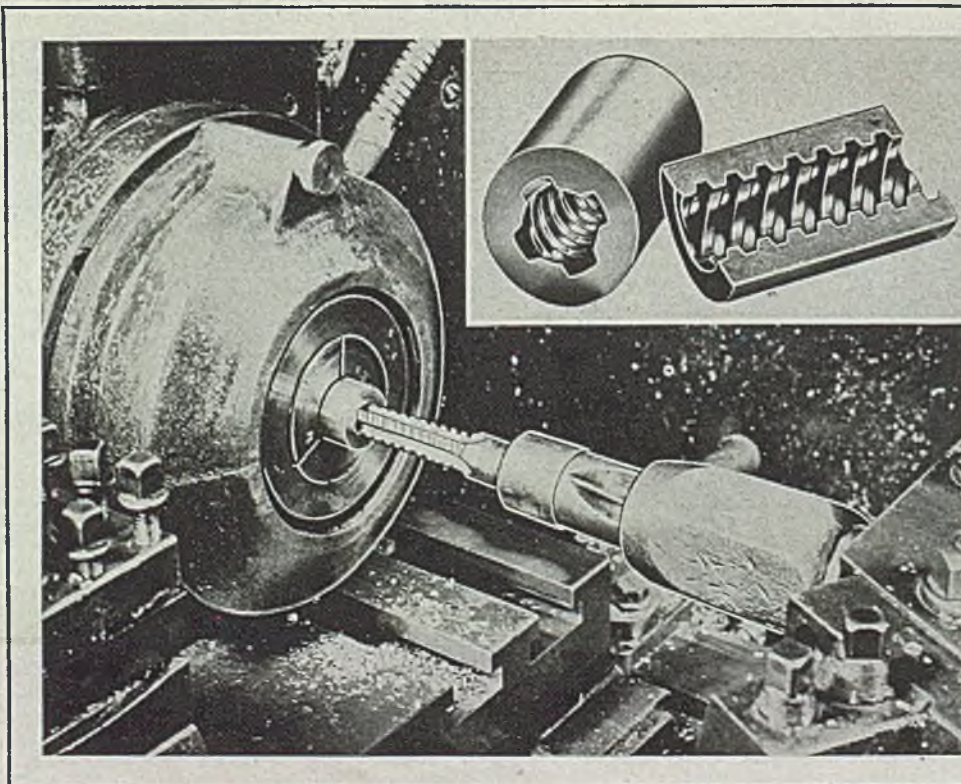

TAPPING QUADRUPLE THREADS: Special bronze nut, see inset, which has quadruple 29° Acme thread is now threaded in five steps on Universal turret lathe instead of chasing thread on lathe with single point cutting tool. Shown here is one step in tapping sequence at Westinghouse Electric Corp., Pittsburgh; shank of each tap is notched to aid operator in selecting correct tool in series. Same method is said to have been applied to a ¾-½ double thread monel nut

FOUR-HIGH COLD MILLS

Designed and Built by

MESTA

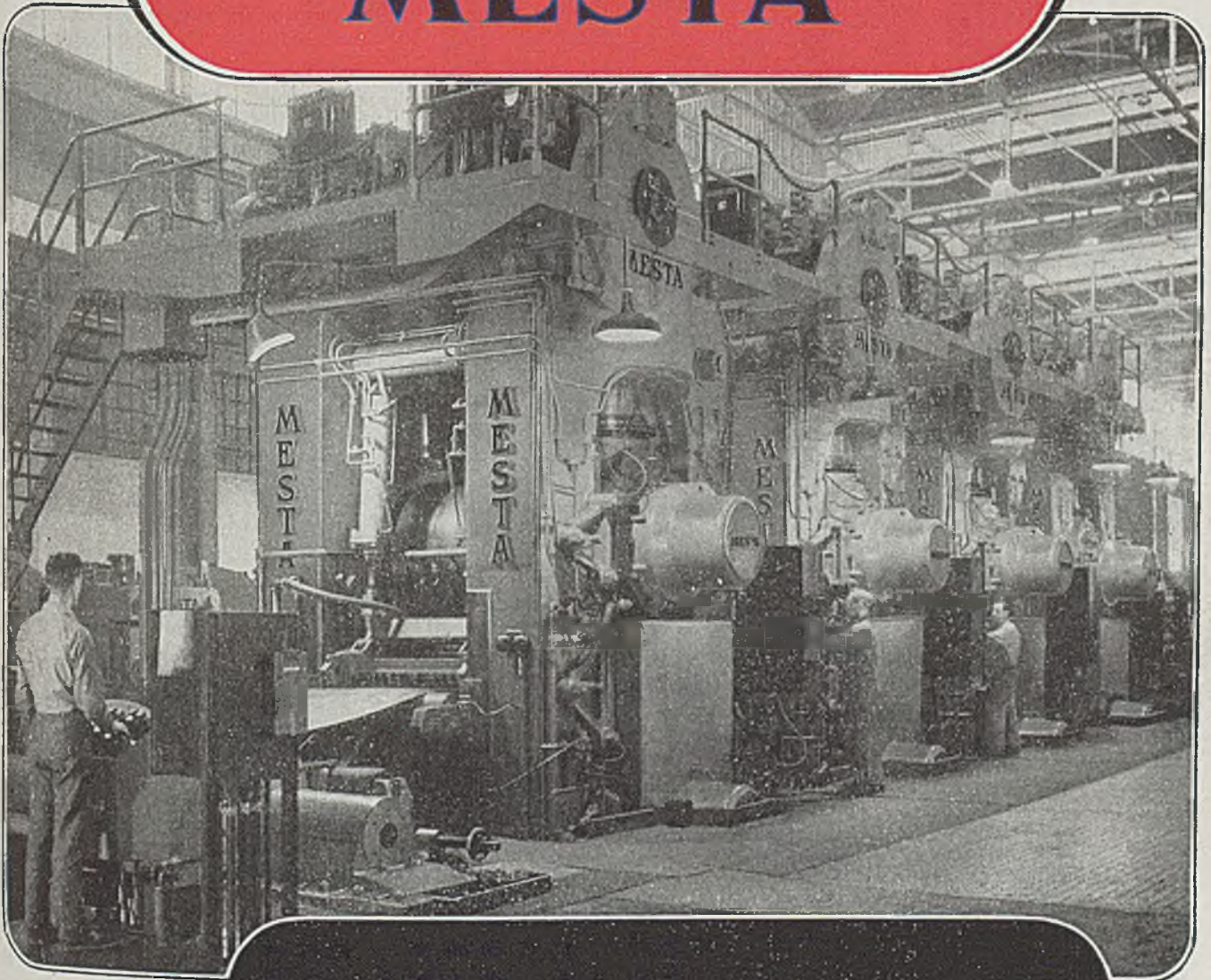

**FOUR STAND TANDEM FOUR-HIGH MILL
FOR THE COLD REDUCTION OF THIN
SHEET STRIP AND GALVANIZING STOCK**

MESTA MACHINE COMPANY
PITTSBURGH, PA.

ENGINEERING NEWS

at a glance

DEEPER magnetic housing and use of more copper enable a 65-in. diameter lifting magnet, currently produced by Electric Controller & Mfg. Co., Cleveland, to handle 25 to 35 per cent larger loads than its standard magnet of existing charging box and buggy design. Its construction permits the use of a full diameter coil in the coil space.

AMONG recent labor-saving developments which harness air for manipulating heavy work are two cylinders—an air and hydraulic type—currently produced by Anker-Holth Mfg. Co. at Port Huron, Mich. The former is a heavy-duty mill type cylinder designed principally for steel mills and shops where heavy handling operations take place. Made for 10 mountings and in sizes from 3 to 20 in., it contains no tie rods, utilizing keeper ring construction. Like the air cylinder, the hydraulic unit features the same type of construction. It has two-way action and is cushioned at no increase in overall length. Both type cylinders are designed for pressures up to 1000 psi.

ALUMINUM coatings on steel are generally recommended for immersion in hot fresh water, particularly hard water, according to the Metallizing Engineering Co. Inc., Long Island City, N. Y. There is, however, considerable variation in the life of coatings, depending on the nature of the water. Generally, the aluminum stands up very well in hard water and in most soft waters. Some soft waters, however, reduce the life of aluminum coatings considerably.

APPLICATION of shot peening to modern metalworking production requirements is covered in a booklet prepared recently by Pangborn Corp., Hagerstown, Md., after two years of study. According to the booklet, beneficial effects of shot peening should not blind the prospective user to one im-

portant point. Application is not a matter of ordering equipment from a catalog. Each case of shot peening is a matter of individual study. It is necessary to realize that shot peening must be correctly applied for maximum beneficial results. Otherwise—like many valuable drugs and medicines—taken in an overdose, the result can be harmful. Fully illustrated with drawings, charts and photographic reproductions, the publication is available on request.

CONSIDERABLE engineering ingenuity is necessary in these days of materials shortages to keep production going. As one example, Westinghouse Electric Corp., Pittsburgh, had enameled magnet wire in stock, but required double cotton covered wire for a certain application. Problem was solved by covering the enameled wire with one thickness of cotton.

MANUFACTURING rights on a wax-type drawing compound, developed some time ago, were sold recently by Plasteel Corp., it was reported from Detroit. The company now is concentrating on the production of plastic novelties.

FLUORINE is now available in steel pressure cylinders on a limited commercial basis for experimental use by manufacturers and researchers, Pennsylvania Salt Mfg. Co. revealed in Philadelphia recently. This is reported to be the first time the gas, most chemically active element known, has been offered on the market by the company. Its activity is so great that it defied isolation for 73 years after its discovery 133 years ago. According to Leonard T. Beale, company president, possible uses of fluorine are so enormous that Pennsalt officials feel the best scientific minds of the country should be given every opportunity to work with the gas. Scientists foresee a whole new field of chemistry in the de-

velopment of fluorine compounds. Developments predicted include insulation for electrical voltages now not possible, and lubricating oils so stable that they will not oxidize or break down under any present engine or mechanical operation.

DOMESTIC cobalt-bearing manganese deposits processed by electrolytic methods developed by the Bureau of Mines, may become an important reserve of cobalt, it was learned in Washington recently. Valuable data on the location of domestic manganese deposits and the cobalt content, together with descriptions of the laboratory techniques employed, were prepared in publication form by the bureau. Its study of the cobalt content of the manganese ores was made in view of the potential importance of these deposits as an emergency reserve.

AUTOMOTIVE designer William B. Stout of Detroit, who recently revealed a radical design of a prefabricated house for GI's, *STEEL*, July 29, 1946, p. 58, declares his prefab will cost from \$1000 to \$1500 less to construct than a conventional house of similar size. To assemble the Stout house, four steel posts are set into the ground, and the assembled roof is hoisted into position with a crane or automobile wrecking car. Because the steel supporting posts remain outside the house instead of within the walls, natural insulation of the house is increased as no steel is present inside to conduct heat or cold from outdoors. About 1 ton of steel is required for construction of the tubular framework of a 24 x 28 ft, 2-bedroom home, and cost of such a structure is estimated to run approximately \$6000.

ALTHOUGH production of metallurgical coke was increased substantially during the past several years, this achievement was somewhat overshadowed by the necessity of supplementing the supply of high-grade coking coals with inferior grades containing high ash and sulphur, a publication recently issued by the Department of Interior, points out. To help meet future emergencies the publication suggests intensive exploration, research, investigation and development of native coking coal resources. In reviewing progress in the various phases of by-product coke operations it discusses methods of determining the suitability of a coal for coke production, coal handling and preparation at by-product coke plants, recent improvements in the design of coke ovens and coke handling. An average analysis of the by-product coke produced in the United States between 1942 and 1944 also is included in the report.



PRODUCTION WITH CARE

The sculptor of delicate figurines is obliged to exercise the greatest care and skill. CHANDLER workers compare with these highly skilled men day in and day out, creating skillfully wrought products with rigidly accurate machines. Our inspectors, provided with the finest measuring instruments, mount a constant guard on quality. Result: imperfections don't have a chance at CHANDLER'S, headquarters of custom-made cold wrought products.



CHANDLER PRODUCTS CORP.
1491 CHARDON RD. CLEVELAND 17, OHIO

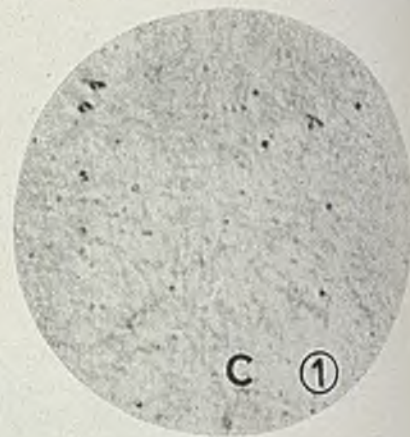
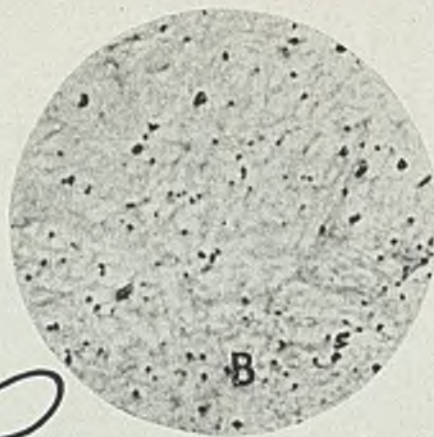
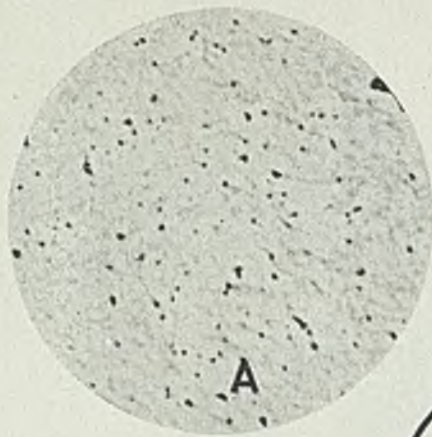

Effect of UNDISSOLVED CARBIDES on HARDENABILITY

Best results in heat treatment are obtained only if austenite composition is given careful consideration. If attainment of this ideal induces prohibitive costs, then use of higher alloy content steels is warranted

DEPTH of hardening, especially in plain carbon steels, is determined by the rate at which austenite will transform to pearlite. Since hardenability may also depend on this rate, it is important to observe the sometimes hidden factors that influence austenite decomposition.

The structure that first forms at a specific austenitizing temperature, from the cementite-ferrite aggregate, is not homogeneous but contains undissolved carbides and carbon concentration gradients in austenite, both of which may adversely affect hardenability^{1, 2}. Free carbide and carbon concentration gradients may exist in the temperature range where austenite is the only stable phase; fortunately therefore they will disappear with time at temperature. Complex alloy carbides, notably vanadium, go into so-

By R. J. HAFSTEN

lution slowly and may be responsible for shallow hardening.³

Solution of carbide and its diffusion in solid solution is a time-consuming

process and does not take place instantaneously as one may expect. Carbides that are not in solution at time of quenching result in lower hardenability, not only because the carbon and possibly alloy content of the residual carbides is lost, insofar as the austenite is concerned, but because the undissolved carbides act as nuclei for pearlite and increase its nucleation rate.²

Roberts and Mehl discovered that free carbide embedded in austenite caused the solid solution, on cooling below the A_{c1} , to transform to pearlite prematurely.

Fig. 1—Microstructure of 0.65 per cent carbon steel showing relationship between time at 1400° F and homogeneity of austenite. Sample shown in micrograph A was water quenched after 15 min at 1400° F, that in B after 90 min, and that in C after 240 min. The inhomogeneity of austenite is shown by presence of undissolved carbides which appear in micrographs as dark specks. Picral etch.—Magnification 1500X

Fig. 2—Effect of structures of Fig. 1 on the stability of austenite at 1300° F. Sample of photomicrograph A was austenitized 15 min at 1400° F, that of B for 90 min, and that of C for 240 min. All specimens were then cooled to 1300° F, held 2 hours, water quenched. Any untransformed austenite would, on quenching, become martensite (light areas in photomicrograph B and C). Dark areas are pearlite. Picral etch.—Magnification 50X

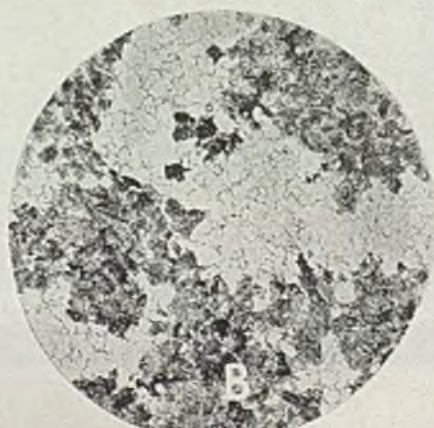
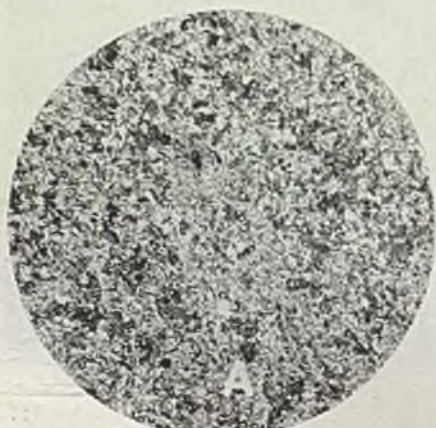

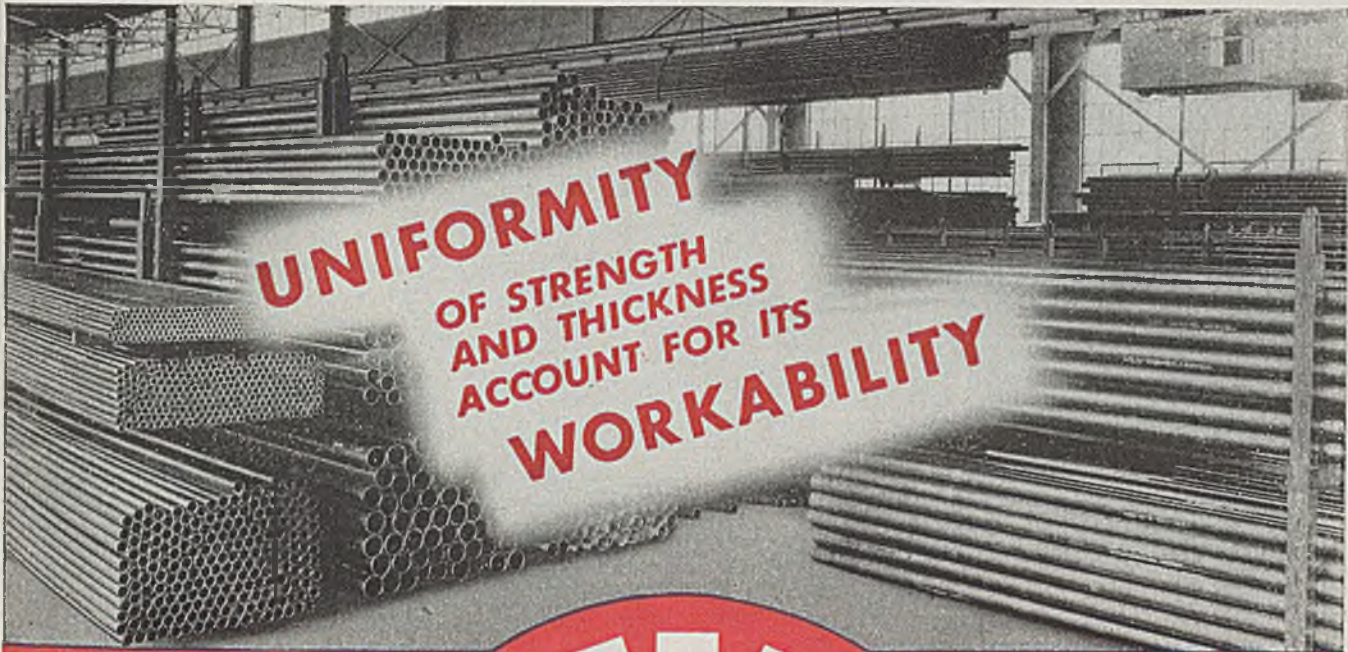

**UNIFORMITY
OF STRENGTH
AND THICKNESS
ACCOUNT FOR ITS
WORKABILITY**

Michigan **STEEL** WELDED **TUBING**



ALSO
SQUARE • RECTANGULAR
Minimum dimension 1/4"
Maximum dimension 2 3/4"
14 to 20 gauge.

1/4" to 4" O.D.
9 to 22 gauge

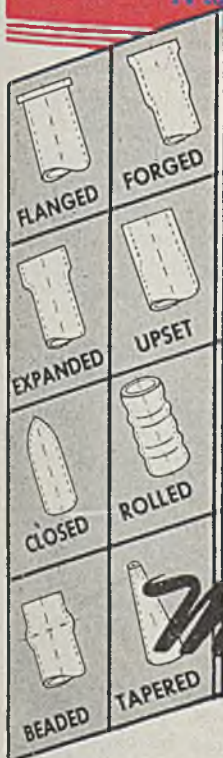

The "Production Parts Tubing"

Because it re-forms and machines so well, Michigan welded steel tubing is widely used in the fabrication of production parts such as automobile exhaust and muffler tail pipes, gas tank filler tubes, steering jackets,

and wherever bent and shaped tubes may be required. True concentricity, uniform I. D. and O. D. make it particularly economical when long runs are involved.

Prefabricated Parts or Tubing

Michigan will furnish the complete part fabricated from welded steel tubing, all re-formed and machined. If you have the equipment and capacity in your own plant to do this work,

consider Michigan as your source for tubing in the sizes listed above—commercial mill lengths or cut to special lengths.

Engineering advice and technical help in the selection of tubing best suited to your needs.

Michigan **STEEL TUBE PRODUCTS CO.**

More Than 25 Years in the Business

9450 BUFFALO ST. • DETROIT 12, MICHIGAN
FACTORIES: DETROIT, MICHIGAN • SHELBY, OHIO

DISTRIBUTORS: Steel Sales Corp., Detroit, Chicago, St. Louis, Milwaukee and Minneapolis—Miller Steel Co., Inc., Hillside, N. J.—C. L. Hyland, Dayton, Ohio—Dirks & Company, Portland, Oregon—James J. Shannon, Milton, Mass.—Service Steel Co., Los Angeles, Calif.—American Tubular & Steel Products Co., Pittsburgh, Pa.—Strong, Carlisle & Hammond Co., Cleveland, Ohio—C. A. Russell, Inc., Houston, Texas—Drummond, McCall & Co., Ltd., Toronto, Canada.

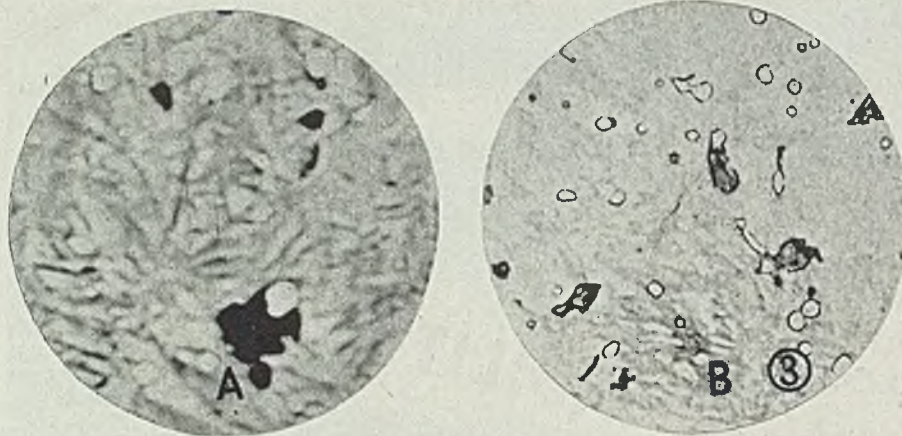

Fig. 3—Structure of quenched 1.00 per cent carbon steel. Specimens were oil quenched from 1600° F. Micrograph A shows a nodule of fine pearlite that had formed around an undissolved carbide. Picral etch—Magnification 3000X. Photomicrograph B also shows fine pearlite nucleating at residual carbide—*austenite* interfaces. Picral etch—Magnification 1500X

This was evidenced by a shift of the isothermal curve, for 0.78 per cent carbon steel, to the left toward shorter transformation times.² Williams proved that hardenability, as measured by the Jominy test was directly related to the degree of heterogeneity of the structure formed at the austenitizing temperature and the optimum in hardenability could be obtained from a homogeneous solid solution.⁴

To illustrate the behavior of a heterogeneous austenite, Fig. 1 shows the structure that existed at the austenitizing temperature for various periods of time and Fig. 2 the corresponding percentage transformation after these austenites were cooled to 1300° F, and held for 2 hours. After the 2 hour period at 1300° F had elapsed, the ½-in. diameter specimens were quenched in water. Any untransformed austenite would appear in the specimen as martensite and the progress of the transformation of austenite to pearlite could be followed. The specimen austenitized at 1400° F for 15 min had completely transformed to pearlite during the 2 hour hold at 1300° F while other two specimens austenitized for longer times were only partially transformed. These photomicrographs tend to reveal that the rate of austenite decomposition is closely related to the condition of the austenite prior to cooling.

It has been firmly established that the most important factor in a spheroidizing anneal is the presence of sufficient undissolved carbides in austenite which cause the normal austenite-pearlite reaction to be replaced by the austenite-spheroidite transformation.⁵ A structure composed of undissolved carbide and austenite will, on slow cooling, precipitate carbide on the residual carbides and the resultant structure will be spheroidal instead of pearlitic. Considering this be-

havior and the work of the investigators previously mentioned, there remains little doubt that free carbide in austenite will also nucleate pearlite.

It is the general opinion that very minute undissolved carbides, not detectable under the microscope, exert the greatest influence on the rate of nucleation of pearlite. This is probably due to the number of carbides present rather than to carbide size.

Photomicrographs Obtained

Following the old adage "seeing is believing," an attempt was made to secure a photomicrograph of a visible residual carbide nucleating pearlite. A 1.00 per cent carbon steel was chosen for the reason that large residual carbides could be produced, making observations under the microscope more conclusive.

Fig. 3 represents specimens that had been oil quenched after austenitizing at 1600° F for 15 min. The quench, not rapid enough to produce 100 per cent martensite, caused a small amount of pearlite to be present in the quenched structure. It can be observed from the photomicrographs that pearlite nodules have been nucleated at the residual carbide-austenite interface. When undissolved carbide is present in austenite it will cause pearlite to nucleate generally throughout the austenite grain and not only at the grain boundary as it would if the austenite were homogeneous.⁶

To obtain homogeneity of austenite it is necessary to select a time-temperature relationship that will cause all carbides to go into solution and eventually diffuse into zones of low carbon content. Although a homogeneous austenite is an ideal condition insofar as maximum hardenability is concerned, it may not always be practical to obtain such an austenite. Often it is more economical

to select a steel with higher alloy content and greater initial cost rather than attempt to produce a homogeneous austenite where prohibitive costs are liable to be incurred from uneconomical high hardening temperatures or long periods of time at these temperatures. Nevertheless, it becomes apparent that careful consideration must be given to austenite composition if best results in heat treatment are to be obtained. No one wishes to pay the extra cost for alloy steel and not derive all the benefits, yet money and alloys are often wasted by factors that subtract from the inherent ability of a steel to produce maximum hardenability.

REFERENCES

- ¹G. A. Roberts and R. F. Mehl, "The Mechanism and the Rate of Formation of Austenite from Ferrite-Cementite Aggregates", Transactions, American Society for Metals, Vol. 31, 1943.
- ²G. A. Roberts and R. F. Mehl, "Effect of Inhomogeneity in Austenite on the Rate of the Austenite-Pearlite Reaction in Plain Carbon Steels", American Institute of Mining and Metallurgical Engineers, Technical Publication No. 1658.
- ³F. B. Foley, "Shallow Hardening, Factors Causing It", Metals Progress, April, 1936.
- ⁴C. T. Williams, "Hardenability Variations in Alloy Steels—Some Investigations with the End-Quench Test", Transactions, American Society for Metals, Vol. 28, 1940.
- ⁵P. Pynson, W. L. Hodapp and J. Leeder, "The Spheroidizing of Steel by Isothermal Transformation", Transactions, American Society for Metals, Vol. 27, 1939.
- ⁶Thomas G. Digges, "Transformation of Austenite on Quenching High Purity Iron-Carbon Alloys", Transactions, American Society for Metals, Vol. 28, 1940.

SAE Issues Book on Ferrous Casting Repair

Compilation of six reports on process control and repair of ferrous castings is being offered by Society of Automotive Engineers. Developed by experts on steel, malleable iron and gray iron castings representing commercial foundries, motor vehicle manufacturers, consultants and Army and Navy personnel, the 145-page book was compiled by committees of SAE at the request of Army Ordnance Department.

Subjects covered in recommended procedures for process control include a detailed discussion of various melting processes, molding, cleaning, heat treating and material specifications as well as a general outline of the pitfalls that threaten the foundryman. Various casting repair methods such as oxyacetylene, metal arc, plugging, peening, use of sealers, brazing, soldering and rusting are also included in the discussions covered in the reports.

Copies of the book, which also contains tables, charts, photographs and a bibliography, may be obtained from the Society, 29 West 39th street, New York 18. Price to members is \$1.50 and it is available to nonmembers for \$3.00.

IT'S A FACT!



It's a better known fact

THAT J&L TIN MILL PRODUCTS HAVE THE QUALITIES THAT GIVE LONG SERVICE

The controlled temper and uniform gage of J&L Tin Mill Products make it possible for them to go through your shaping and forming operations with best results. Their superior surface improves the attractiveness of any product and provides excellent adhesion for lacquers, porcelain enamel and plastic coatings as well as lithographed and painted designs.

J&L Hot Dipped and Electrolytic tin plate and terne plate have the evenly distributed coatings necessary to make soldering operations go smoothly and to provide full protection for the desired service life.

JONES & LAUGHLIN STEEL CORPORATION

PITTSBURGH 30, PENNSYLVANIA

August 19, 1946



FOR Specialized STEEL SERVICE

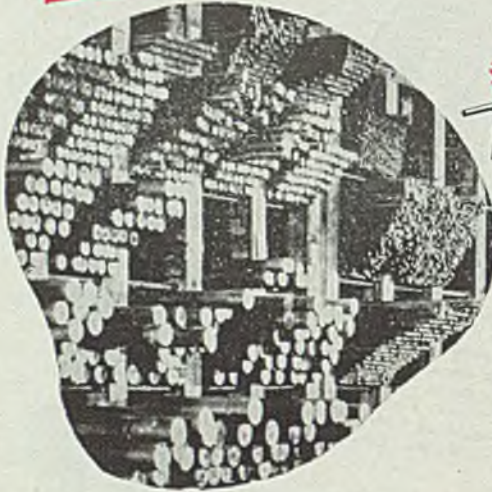

**COLD FINISHED
BARS...
SHAFTING**

Complete stock of all carbon grades in Rounds—Squares—Hexagons—Flats.

**Specify
GENSCO
STEEL**

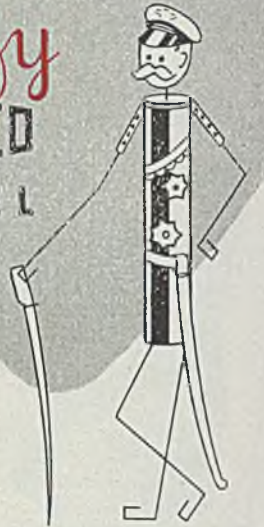

ANNEALED AND TEMPERED SPRING STEELS

Gensco offers a complete range of sizes and grades of Annealed and Tempered Spring Steels.

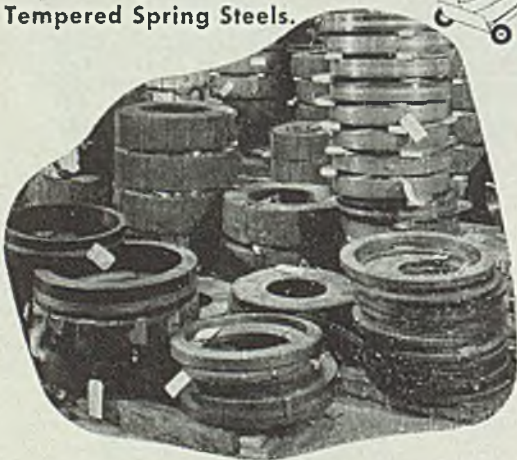

COLD ROLLED STRIP STEEL

Expertly packed for safe delivery—in Coils and Straight lengths—all Gauges and Tempers.

COLD ROLLED STRIP STEEL • COILS AND STRAIGHT LENGTHS • SHEET STEEL
COLD FINISHED BARS • SHAFTING • ROUND EDGE FLAT WIRE
ROUND WIRES • TEMPERED AND ANNEALED SPRING STEEL
SHIM STEEL • FEELER GAUGE • DRILL ROD • STEEL BALLS

GENERAL STEEL WAREHOUSE CO., INC.

1830 N. Kostner Avenue, Chicago 39, Illinois • Belmont 4266

New York 17
441 Lexington Ave.
Vanderbilt 6-2750

Cincinnati 17
56 E. Mitchell Ave.
Plaza 1470

Milwaukee 2
208 E. Wisconsin Ave.
Broadway 7629

St. Louis 5
9301 Bonhomme Road
Wydown 1368

Minneapolis 11
100 17th Ave., North
Cherry 4457

One manufacturer finds it possible to save as much as 7240 lb on one box car by using lightweight high strength steels in its car construction program

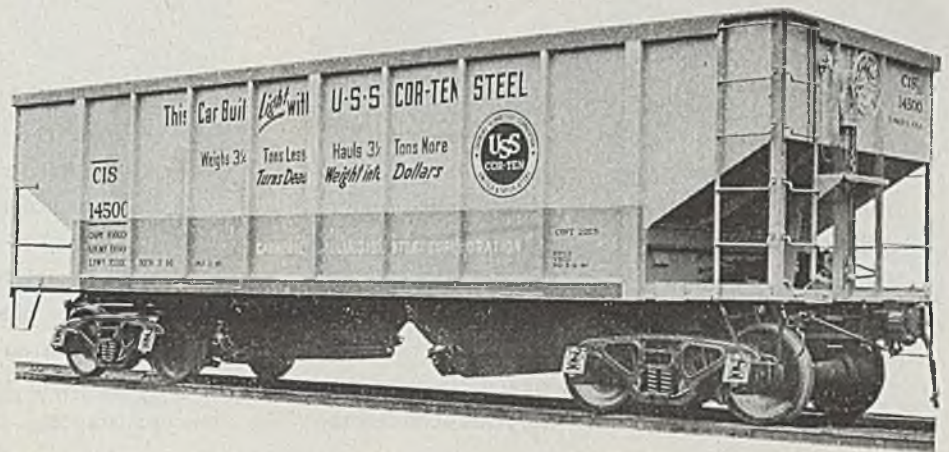

HIGH-STRENGTH STEELS GIVE RAILROADS STURDIER AND

Lighter Freight Cars

LIGHT WEIGHT railroad cars of high strength steel are being widely accepted in the railroad industry which is giving increased attention to attempts to reduce non-revenue freight loads. It is the relationship between dead weight and lading that is the key to operating efficiency.

A practical demonstration of what can be accomplished with lighter freight equipment built of high strength steel is shown in following facts. Comparing figures of 1935 with those of 1920, one railroad had a 13 per cent rise in ratio of dead weight to load. In 1935, installation of light weight, high strength steel equipment was begun by this railroad. By 1940, the influence of new cars had made itself felt to such an extent that dead weight ratio had dropped 19.6 per cent below 1935 and 9.2 per cent below 1920. These facts deserve attention as Class I railroads, considered as

a whole, had an increase of 35.1 per cent in ratio of dead weight to lading from 1920 to 1935.

Adaptability and versatility of high strength steels are shown in variety of equipment in which they are applied. Designers of box, automobile and refrigerator cars have used these steels in various combinations of spot welded, fusion welded and riveted constructions, which in general are intended to provide strength equal to that of conventional cars with a substantial reduction of dead weight.

Many railroads are adopting high strength steel for box car bodies because these cars are heavy in relation to the normal loading. Over 30,000 box cars of this type are in service. A conventional class X-38 box car, 50 ft 6 in. long, constructed of copper steel by Pennsylvania railroad, weighed 55,300

lb. A car of same size, constructed of high strength steel and assembled largely by welding, weighed only 45,400 lb. This car, designated as class X-41, had trucks weighing 2650 less than class X-38 car, making a total weight reduction due to use of high strength steel and welding alone of 7240 lb.

Hopper, gondola and ore cars involve problems not found in house cars, because open top equipment is often subject to more corrosive conditions, abrasion and abusive service. Some railroads want this type of car built of high strength steel with maximum practical reduction of sections to decrease weight and increase capacity, at same time aiming for strength and service life equal to conventional equipment. Other roads use these steels with no reduction of section, to decrease maintenance costs and lengthen life of car structure, while many roads choose a compromise design, one which gives both a substantial increase in service life and a substantial decrease in weight.

An indication of serviceability of high strength steel which has improved corrosion resistance can be gained from ex-

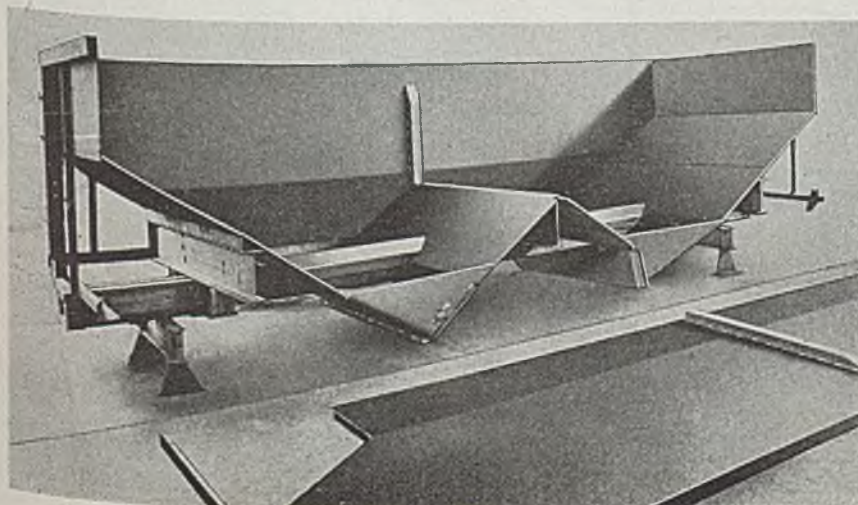

Fig. 1 (above)—Welded Cor-Ten steel hopper car which was fabricated with weight reduction of 6540 lb

Fig. 2 (left)—Partly fabricated Cor-Ten steel car showing details of construction. Entire side section is subassembled before assembly as shown here



THE FACT that *every* rivet can be counted on for well-formed, on-center heads; round, close-tolerance shanks; uniform lengths; and freedom from scale and foreign matter that would interfere with automatic feeding . . . has given RB&W its reputation for high-quality rivets and has made RB&W one of the world's largest manufacturers of small rivets.

RB&W's program for developing its manufacturing facilities during the next two years includes the

installation of many new high-production rivet headers which will substantially increase capacity.

Such investments in new machinery are typical of RB&W's policy of using modern research, manufacturing and quality control methods in order to deliver to its customers bolts, nuts, screws, rivets and allied fastening products that will save time in assembly, provide an extra margin of holding power, and will conform to the customers' requirements for fine appearance.

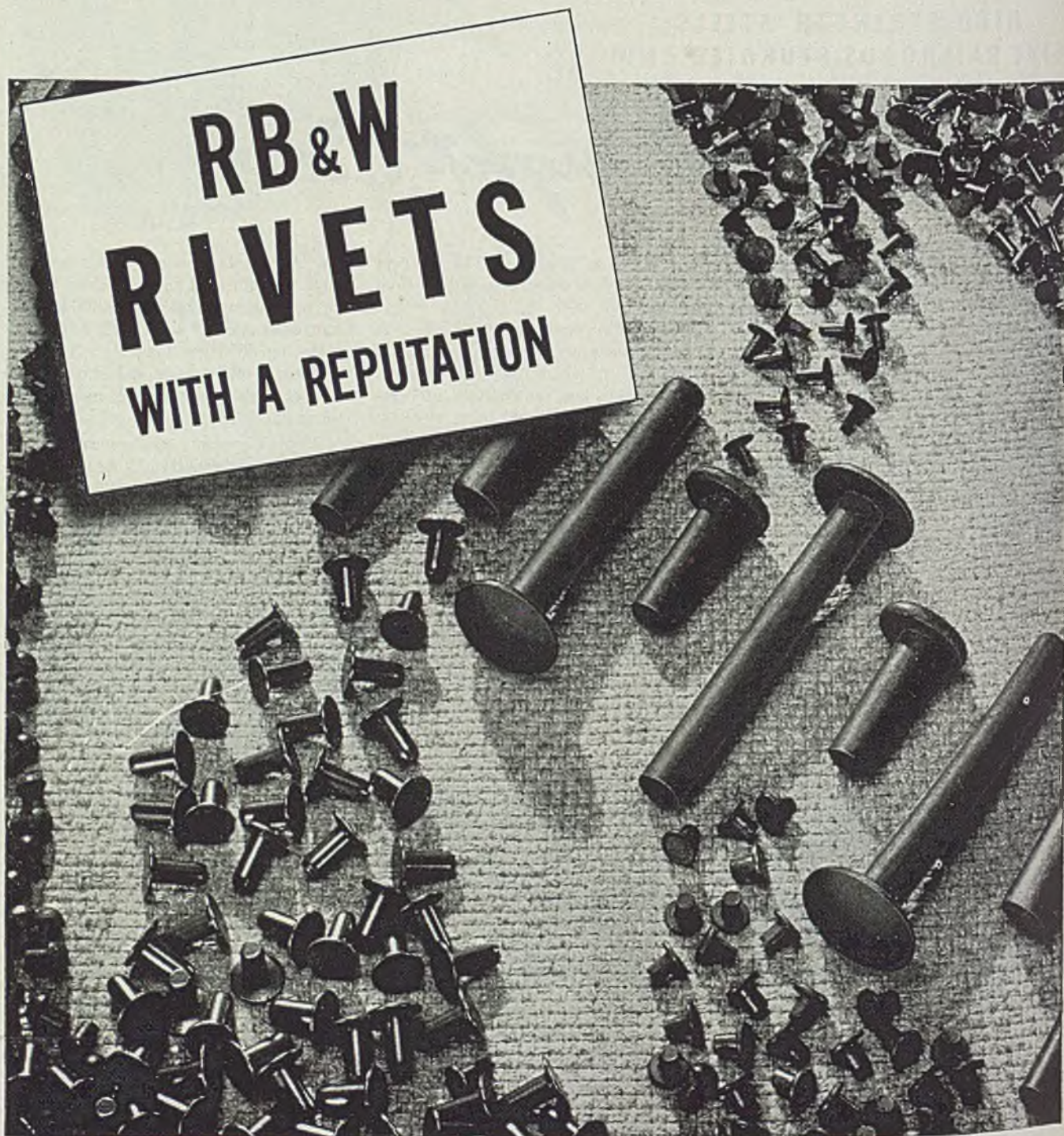

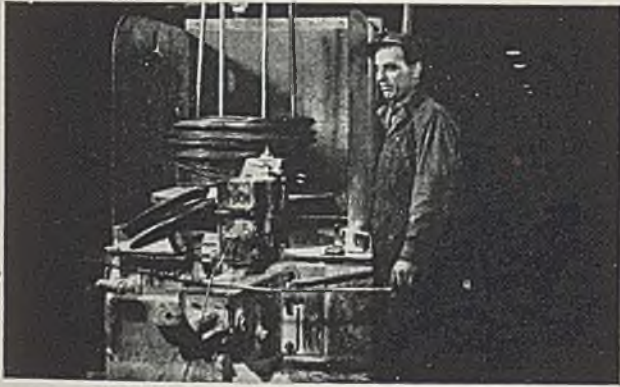

ACCURATE WIRE — First step in assuring close control over dimensions of rivets and bolts is drawing the wire. RB&W draws its own wire, and the use of tungsten carbide dies guarantees extremely close tolerances.



ANNEALING—In gas-fired batch-type draw furnaces, RB&W rivets are annealed to remove cold heading stresses and to assure proper hardness. These furnaces are accurately controlled to provide thorough and accurate heating.



Each of the products in the RB&W line — which covers a complete range of fastening requirements — has been engineered to high standards of accuracy, strength and appearance.

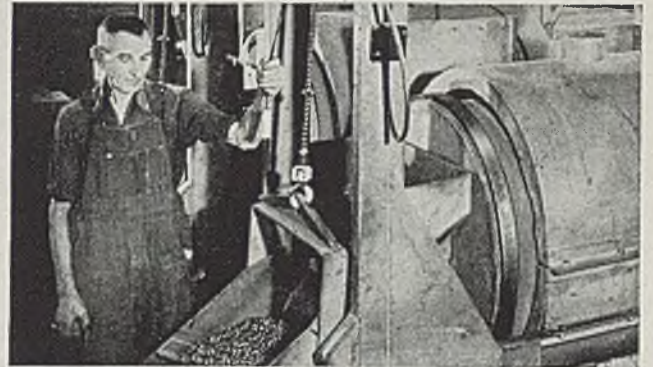

CLEAN RIVETS — Tumbling RB&W rivets makes them smooth and clean and removes all foreign matter. Free from scale and dirt, these rivets feed freely in automatic machines and provide a positive metal-to-metal contact in the rivet hole.



STOCK ROOM—under normal conditions, prompt deliveries are assured from a large and complete inventory of all stock-production sizes. Handling facilities are of the most modern type.

101 YEARS *Making strong the things that make America strong*

Plants at: Port Chester, N. Y., Coraopolis, Pa., Rock Falls, Ill. Sales Offices at: Philadelphia, Detroit, Chicago, Chattanooga, Los Angeles, Portland, Seattle, Distributors from coast to coast. By ordering through your distributor, you can get prompt service for your normal needs from his stocks. Also, the industry's most complete, easiest-to-use catalog.

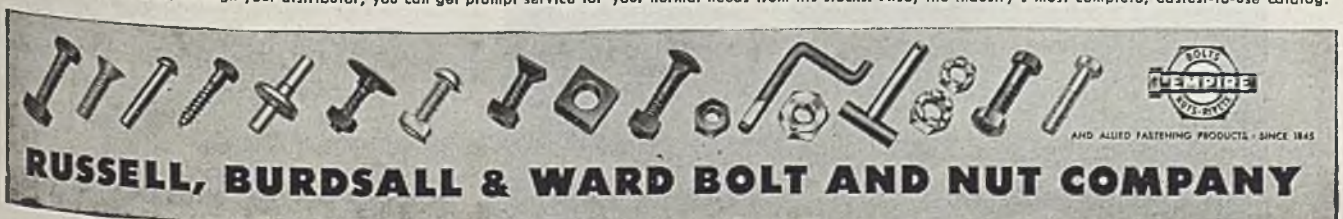

perience with extremely light 50-ton hopper cars weighing 30,500 lb built by Pressed Steel Car Co., Pittsburgh, in 1935. In these cars, sides and ends were reduced from $\frac{1}{8}$ -in. to $\frac{3}{16}$ -in.; the floor, usually $\frac{1}{4}$ -in. thick, varied from $\frac{3}{16}$ -in. at top to $\frac{1}{2}$ -in. at bottom. None of these cars has required overhauling for replacement of sides or floors in 11 years of service on three roads.

An example of the high strength steel car is the one built of United States Steel Corp. Cor-Ten steel after studies of operating records by Railroad Research Bureau of that company's subsidiaries. Built for Carnegie-Illinois Steel Corp., this car, shown in Fig. 1, utilizes standard sections and plates with straight trim and simple cold bends for economy and simplification in fabrication. Car structure is designed for sub-assemblies to facilitate final assembly and permit position welding. Smooth interior surface permits free flow of lading during unloading

and eliminates moisture collecting pockets.

Each side of the car is a main sub-assembly, as shown in Fig. 2, the lower side sheeting being heavier as it receives greater wear. Heavier sheet runs from bolster to bolster and serves as a framing member for attachment of all cross members and floor sheets. Welded tubular center sill allows maximum unloading area in hopper door openings, permitting a one-door opening across car. Hopper sheet is formed by two simple cold bends and extends in one piece across the entire car.

Reduces Overall Expenses

Present outlook seems to be that operators will be increasingly interested in adopting all practical means of reducing overall expenses as competition probably will be intensified in the next few years. Operators are also of opinion that increased wage rates will bring about in-

crease in unit costs. To cut expenses, it is desirable to decrease ratio of tare ton miles to revenue ton miles by use of high strength steels. Of these steels, Cor-Ten alone has been applied to more than 62,000 freight cars that are in service on railroads throughout the entire United States.

Design committee of American Railway Car Institute and Committee on Car, Construction of the Mechanical Division of Association of American Railroads have designs in preparation for freight cars of high strength steel. It is intended to have these designs adopted as alternate standards for box car, 50 and 70-ton hopper car, fix-end and drop-end gondola construction. This is an indication of a more general acceptance of light weight high strength freight cars and it can be expected to accelerate adoption of such equipment by roads that wish to adhere to the standard designs of the AAR committee.

Second Operation Lathe for

PRECISION MACHINING

NEW second operation precision lathe designed for high speed production at close tolerances was placed in production recently by Hardinge Brothers Inc.,

Elmira, N. Y. Machine incorporates dovetail design on steel bed ways to protect angular way surfaces from falling chips and foreign matter, and three-point

mounting on welded steel pedestal base which is said to insure original bed accuracy even when machine is placed on an uneven floor.

Preloaded ball-bearing spindle construction of headstock is ground to take 1-in. collets and 6-in. capacity step chucks; spindle nose is supplied with either standard taper or threaded nose for direct application of step chuck closers, jaw chucks and face plates. Balanced bearing spread and equal distribution of belt pull is obtained by center drive construction that places belt between spindle bearings. Ball bearing connected to operating lever aids ease of operation in closing and opening collets or step chucks instantly.

Turret head is mounted on preloaded ball bearings which are said to eliminate all play between turret head and slide; index pin is set on roller bearings in order to eliminate radial play.

Other features of machine shown include double tool cross slide which has a full bearing on base to assure rigidity. Cross slide tool posts take standard $\frac{3}{8}$ -in. square tool bits. Regular tool posts can be removed and No. 00 circular form tools and holders applied to cross slide. Electrical equipment is built in, providing magnetic control with time lag thermal overload relays and low voltage protection.

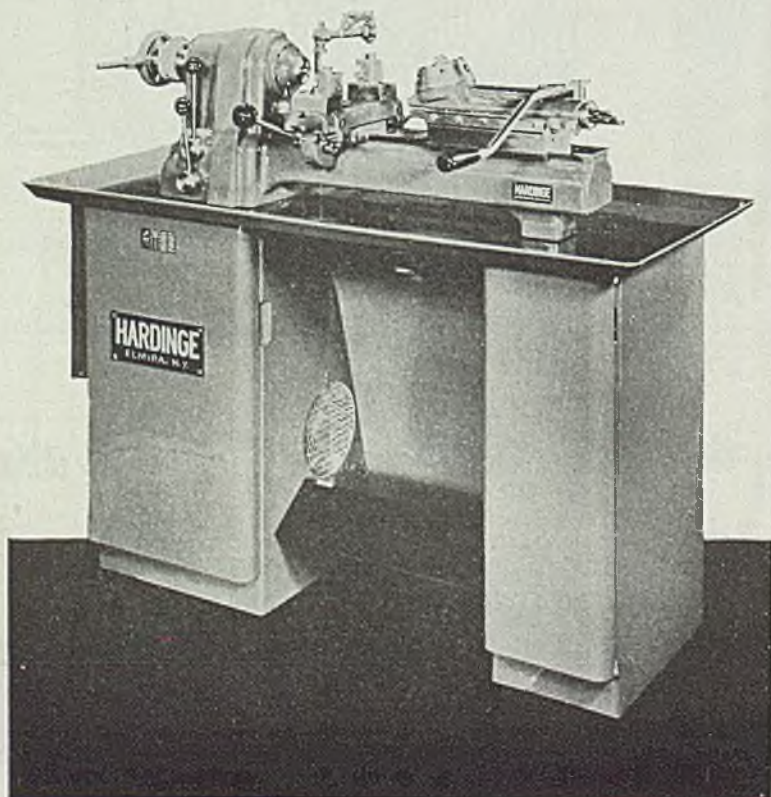

**NOW THAT TIMKEN
IS PROCESSING NEW STAMINA
INTO ALLOY STEELS . . .**



COPYRIGHT 1946 BY THE TIMKEN ROLLER BEARING CO.

TIMKEN
Trademark Reg. U. S. Pat. Off.
Fine Alloy
**STEEL AND
SEAMLESS TUBES**

—look for extra values in heavy equipment

Sudden jerks, impacts and shocks are unavoidable in the operation of construction machines and heavy materials handling equipment. Because alloy steel gears, shafts, pins and vital parts sometimes must resist terrific unexpected stresses, most of them are formed by forging processes.

Forging kneads the steel into a dense mass of hoarded strength by compressing its structure and directing its grain to best advantage at points of greatest stress and shock. Such treatment requires clean, sound steel with exceptional surface quality and internal quality. But above all, properties which assure uniform response to heat treatment.

Ability of Timken metallurgists and Timken operating men to meet specified forging requirements more closely has led to consistent use of Timken Alloy Steels in earth and material moving machines. And in most other kinds of equipment too, where unusual stresses are concentrated in vital parts.

New developments have been coming thick and fast. A qualified member of the Timken Technical Staff would be glad to tell you how Timken forging steels might be used to advantage in making your product. Write Steel and Tube Division, The Timken Roller Bearing Company, Canton 6, Ohio. *Timken Bearings, Timken Alloy Steels and Seamless Tubes, Timken Removable Rock Bits.*

PEEKING INSIDE A BAR OF STEEL.

It is known now that grain size in alloy steel affects many of its physical characteristics. And that different heats of steel having the same chemical analysis may have very different grain sizes.

Metallurgists of The Timken Company were among the first to prove these facts. They developed a method of "soaking" carbon into the grain of alloy steel so that the boundaries of the grains could be seen and photographed. They developed charts for classifying grain sizes; then found they could predict much more accurately how an alloy steel would respond to heat treatment, and how it would perform in actual use.

Today, checks for grain size are made while a heat of Timken Alloy Steel is still undergoing processing. They are a great help in holding the uniformity which is valued so highly by alloy steel users.

★ YEARS AHEAD — THROUGH EXPERIENCE AND RESEARCH

Eliminates

TOOL CHANGES

By ROBERT MAWSON
Providence, R. I.

Twenty-five-degree serrations can be milled on one setup with milling fixture

ORIGINAL plan for milling 25 degree serrations on a forged steel handle was for all units to be milled at one setup, then changing setup to machine the same units at the other angle. Disadvantage of this system is time necessary to make tool changes is not productive time.

To offset this disadvantage, a fixture was designed so that the two operations could be performed with no time lost for tool changing. A base plate, designated as A in the diagram, was machined with tongues to fit table slots and provision made for bolts to hold it in position. A subbase B is mounted on base A and located by hardened steel stud C, which is drive-fitted into the subbase.

A bracket D is fastened to the subbase by set screws and a locating dowel. The lever, shown by dotted lines, is located by bracket which is so placed that lever is milled at 25 degrees with vertical axis. Lever is placed on pin

E, which is a sliding fit in a $\frac{3}{8}$ -in. ream-hole. Center of serrations is also center of the rest stud C.

A locator F is fastened on upper surface of subbase and two stop brackets G-1 and G-2 are located and fastened on the base plate in the correct alignment for both milling operations at 25 degrees on each side of vertical axis. A handle which is used to turn the subbase is shown at H, and can be placed in any convenient position.

To operate, hook bolt J, which is above pin E in bracket D, is placed over piece and tightened by nut. The serration cutter, mounted on arbor of a hand milling machine, first cuts at one angle when machine table is fed under cutter. By drawing back the table and turning the subbase by means of handle H into other position the other operation is performed.

The table is again drawn back, the piece removed and both serration milling operations have been completed without changing tools.

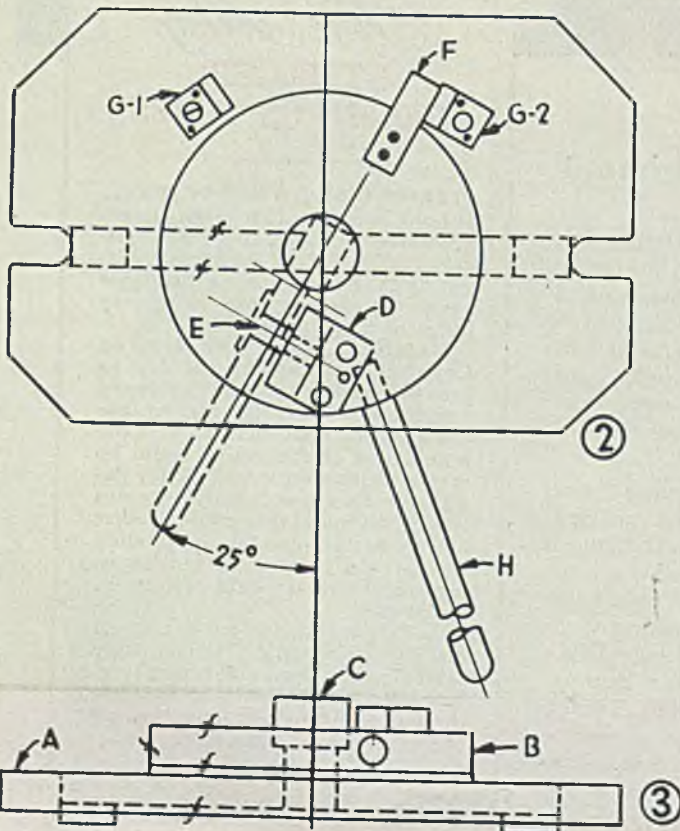
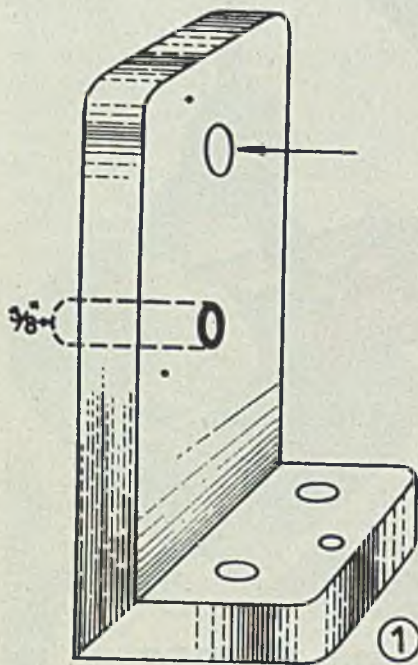
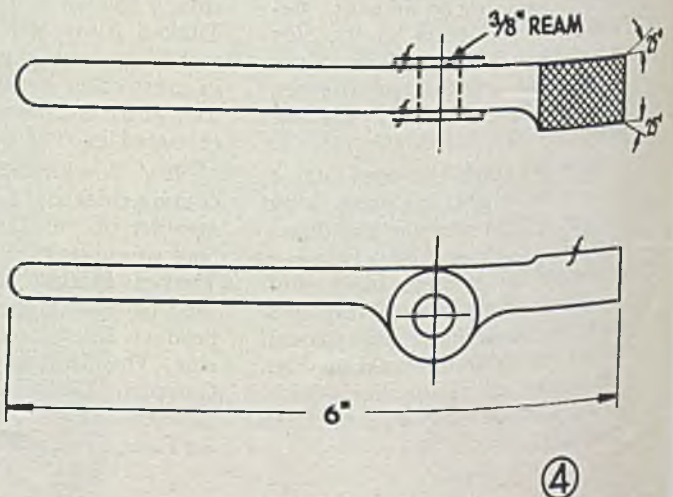

Fig. 1—Bracket D showing pin E on which handle fits to be milled. Hole above pin is for hook bolt J which holds handle in position

Fig. 2—Assembled fixture. Dotted lines show position of handle to be milled

Fig. 3—Side View of base and subplate with bracket D and stud C in position. Hole in subbase is for handle

Fig. 4—Horizontal and vertical views of forged steel handle described here



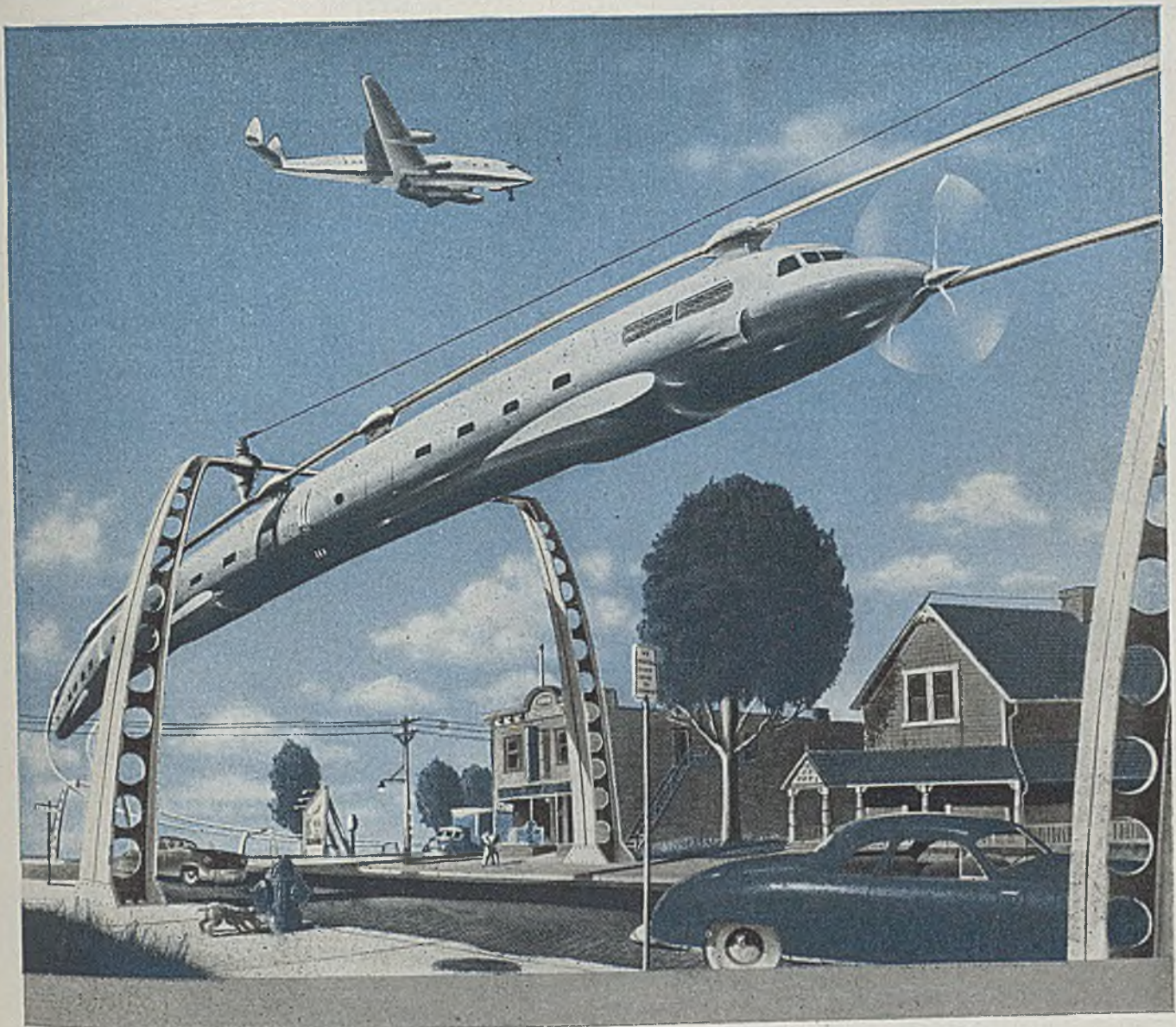

From Airport To Town By Monorail

Getting to and from the airport often takes as long as the time spent in the air on short inter-city hops. Illustrated above is a plan to eliminate this time loss by fast monorail train. You will see new transportation developments—new products—in the days that lie just ahead. In many of these, aluminum and magnesium—fabricated by Bohn—will play an important part because of the great advantages these alloys possess, combining as they do, lightness with great strength, along with many other superiorities. Bohn engineers would like to discuss the merits of these light alloys with you as related to the products you make or intend to make.

BOHN ALUMINUM AND BRASS CORPORATION
GENERAL OFFICES—LAFAYETTE BUILDING—DETROIT 26, MICHIGAN

Designers and Fabricators—ALUMINUM • MAGNESIUM • BRASS • AIRCRAFT-TYPE BEARINGS

BOHN

PROBLEM of which die steel to select for a job which might involve stamping, blanking, drawing, coining or a variety of press and hammer operations in most cases means a labor cost far in excess of the cost of the tool steel from which the die is made. Consequently, the steel that best fits the job is used, the cost mattering but little when compared with the other considerations which govern its selection.

Tool steels are usually purchased in the soft, annealed state for easy fabrication,

a real advantage as witnessed by the fact that dies for cold or warm shearing in steel mills are often made of a carbon steel. The surface is hard, withstanding the severe wearing action of the metal being cut, while the core is tough enough to stand the shock of the process. Dies for wire and bar drawing also utilize this type of steel, the hole being quenched and surrounded by a tough ring. When deeper hardening steels (which harden all the way through) are used for dies, a heavy backing ring has to be shrunk tight

By DR. G. M. BUTLER
Associate Director of Research
Allegheny Ludlum Steel Corp.
Dunkirk, N. Y.

Selection of DIE STEELS

FOR COLD WORKING METALS

*Peculiar characteristics of tool steels of water, air and oil hardening types make each one suited for a particular type of die for cold working**

When completely worked, they are then hardened by heat treatment to give them strength and hardness required when forming other metals.

For the purpose of this article, these steels will be divided into three groups, according to the quenching medium used in their hardening. Classified according to water, oil and air-hardening steels, their properties have a direct relationship to the manner of hardening. The steels to be discussed and their grouping according to quenching method are shown in Table I.

All of these various types of steel are made by several makers of tool steels in the United States. Variations between them are minor—not enough to justify separate classification.

Of the water-hardening steels, the most familiar is straight carbon steel, the oldest of the tool steels. No tool steel, no matter how highly alloyed, gets harder after quenching than this steel. Regardless of the quench, carbon steel cannot be made hard throughout when the diameter is over $\frac{3}{4}$ to 1 in.

The hard surface and soft core can be

around them, as in the case of hammers and punches.

Other advantages of carbon steels are ease of machining and grinding, low hardening temperature, controlled depth of hardening, reasonably good wear resistance, versatility of application, wide range of carbon contents and qualities and low cost.

These steels also have their disadvantages. For example, the shallow hardening feature may mean dies with soft spots may crumble and be pushed down into the core of the die, due to insufficient case thickness to sustain the load. Grinding room redressing may remove the hard surface and there is always the risk of cracking and warping of dies. Wear resistance for long runs is often insufficient.

Use of carbon-vanadium modification of straight carbon steel means a more fool-proof hardening—the steel will withstand more overheating and it is essentially shallow-hardening, more so than many

*This article is from a speech given before a recent meeting of Pittsburgh chapter of American Society of Tool Engineers.

straight carbon steels. A fine grain which adds to shock resistance is attained with a vanadium content. Depth of hardening can be increased by raising hardening temperature. Steels of this type are valuable for such applications as cold heading dies.

It can be seen from the foregoing facts that water-hardening tool steels are not suitable for dies with deep, intricate impressions, or dies which must be hardened all the way through, or those that must have long wearing qualities. Although some of these disadvantages are overcome by martempering, flame or induction hardening, use of welded composite sections, etc., use of carbon steels for dies is definitely limited.

Use of alloy tool steels which can be hardened by less drastic methods than water or brine quenching brings about reduced warpage and distortion and less danger of cracking. Increase in wear resistance, toughness and depth of hardening pays for added cost of alloy elements.

Oil-Hardening Steels

The great majority of die applications can be satisfactorily filled with the second group of steels, those utilizing oil-hardening. Of the many related types of steels which fall in this classification, only high-carbon high-chromium and two types of manganese oil-hardening steels will be covered.

The popular manganese steels are of two types, differing mainly in manganese content. One type contains 1 per cent manganese, along with chromium and tungsten, while the other contains $1\frac{1}{2}$ per cent manganese and molybdenum.

Manganese content tool steels are easy to machine and grind, safely hardened at low temperatures in oil, with little danger of cracking and with low distortion. This steel has moderately deep hardening qualities, good wear resistance and has the ability to hold a keen cutting edge. Some of its applications are for gages, drawing and forming dies, plastic molding dies, master form tools and taps.

Having little of the elements which make hard, wear-resistant carbides, manganese oil-hardening steels do not have wear-resistance in excess of that of the carbon steels. After tempering, both are in the same hardness range. For long-life die steel to be used under severe conditions, 2 per cent carbon—12 per cent chromium oil-hardening is very satisfactory. Being a mass of hard chromium carbides, it is exceptionally resistant to abrasion, at the same time having great resistance to compressive force. It is deep hardening and deforms but little in heat treatment. Its longevity has been proved in such applications as long-run blanking dies, dies for deep-drawing, slitting cutters and forming rolls.

In spite of its virtues, this steel has its

There's a Built-in-Quality
market for

DOWNSPOUTS - GUTTERS - ELBOWS

OF **Superior's**
STAINLESS STRIP STEEL

*-and throughout
the modern home....*

Stainless means quality, in every application for better living in today's American home. And SUPERIOR Stainless Strip Steel has a special meaning of quality to the fabricator. Superior's long coils are uniform grade by grade; in composition, dimensions, temper and finish desired, you get what you want every time. Make Superior your choice for the coming mass stainless demand!

For your files—the detailed
Superior Stainless Brochure!

Superior Steel

CORPORATION

CARNEGIE - PENNSYLVANIA

Wapakoneta SHEAR BLADES and SLITTERS ...



MORE THAN
50 YEARS of Service

THEY HOLD THE EDGE

because they are tempered and ground for your particular needs

Wapakoneta Shear Blades are made and heat treated, **not** to meet some universal standard of our own, but to best fill each customer's requirements... That is why Wapakoneta Shear Blades stand up longer on the job and cut more tonnage.

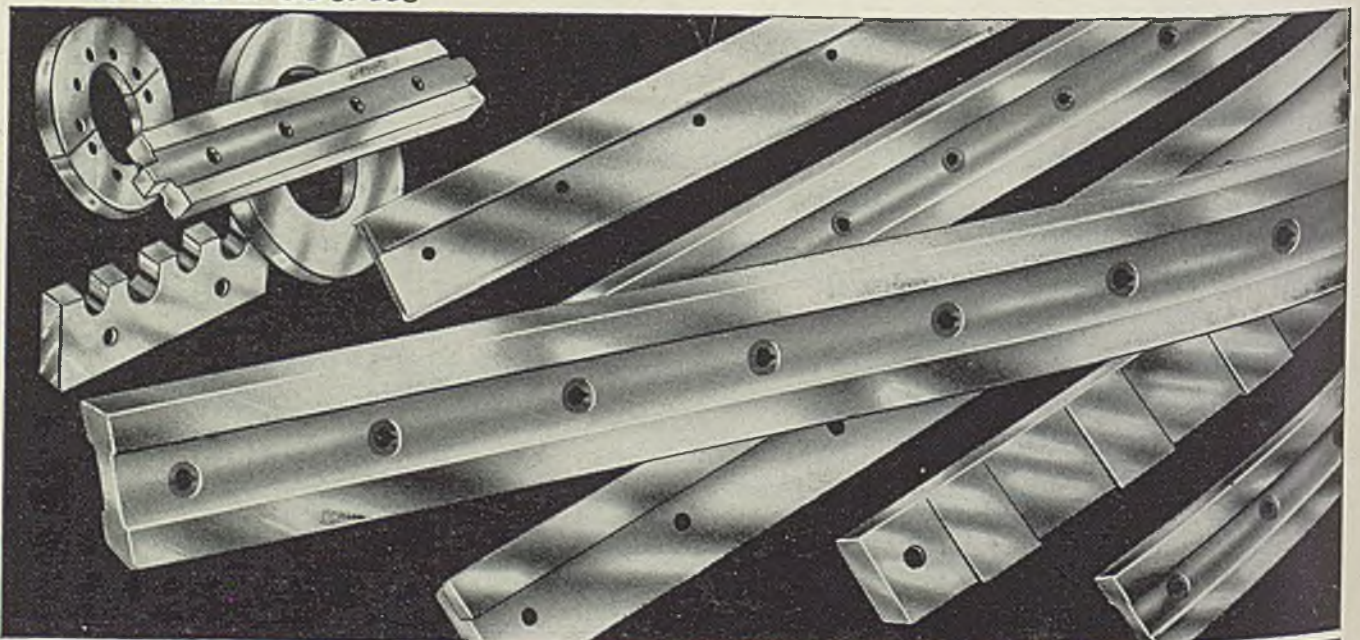

The Wapakoneta Machine Company
INCORPORATED 1891

Wapakoneta, Ohio U.S.A.

disadvantages. Its machinability is poor and grinding it in its hardened state is extremely difficult. Heat treating temperatures are fairly high; it has relatively low resistance to shock or bending and is quite expensive.

The third and last group of die steels is the air-hardening class—a newcomer to the field. These steels grew out of a demand for steels which deformed in hardening still less than the oil-hardening types. Many dies or accurate gages changed dimensionally in heat treating, necessitating expensive grinding or lapping or even complete rejection. Other dies were too susceptible to quenching cracks, even in oil quenching.

Three air hardening steels with a common virtue—almost negligible dimensional change in hardening—were developed. Their use enabled the die-maker to leave little or no allowance for grinding after hardening. All will harden throughout in sections commonly used in die design.

The first air-hardening type, manganese-chromium-molybdenum, hardens in the lowest temperature range and is the least deforming of all die steels. Its alloy content, high enough for a good degree of wear resistance, makes it rather hard

to machine, since it will not anneal very soft. It is not generally available.

* One application of this steel is for ground toolmakers' flats. Usually made of water-hardening steel and hardened in oil in thin sections, this means of fabrication caused considerable distortion, requiring straightening or grinding. Templates, gages and similar parts made of air hardening steel can be hardened by cooling in air from the same temperature as used for carbon steels, showing negligible warping or dimensional change.

A steel which shows a combination of easy, safe hardening, good wear resistance and unusual toughness is the second of the air-hardening steels, the 5 per cent chromium—1 per cent molybdenum type. In spite of its higher hardening temperature, it is increasing in popularity for use for blanking, forming and trimming dies which are usually made of high-carbon high-chromium types of steel. Its lower cost, easier machining and grinding are factors which are influencing this change.

A high-carbon high-chromium steel containing molybdenum to encourage hardening in air is the third air-hardening steel. It has a somewhat lower carbon content than its oil-hardening counterpart. Safety in heat treatment is the factor that accounts for its widespread use.

The die maker, in making a lamination die, or any other intricate blanking die, may choose to make it in one piece or in sections. A one-piece die is best made of an air-hardening type steel. The number of pieces which this one-piece die will produce between sharpening will be slightly less than from an oil-hardening type steel die containing more chrome carbides. Another factor to consider is that the manufacturing cost of the die will be less and it can be hardened with less

warpage and with little fear of cracking.

Dies made of either of these high-carbon high-chromium steels are machined in the soft state, when hardened and finished to size by grinding, filing being avoided. Lack of toughness often leads users to back them up with heavy steel or cast iron blocks.

The recent progress in bright-hardening has made the use of air-hardening steels more attractive. The latest furnaces permit heating and cooling of dies in an inert atmosphere which causes pieces to come out as bright as they went in.

To clarify a few of the important characteristics of these steels, they are arranged in Tables II to V to show their relative behavior. Carbon steels head the list in tendency to distort while manganese-chromium-molybdenum air hardening steel distort the least. It also can be seen in Table II that oil-hardening high-carbon high-chromium steel will distort less than the 5 per cent chromium type of air-hardening steel.

In regard to wear resistance, Table III, oil-hardening high-carbon high-chromium steel is the best. The slightly higher chromium content of the 5 per cent chromium steel gives it a wear resistance edge over the manganese-chromium-molybdenum type. Toughness, Table IV, is influenced by the size of the piece. Since they have a hard surface and a tough core, carbon and carbon-vanadium steels head this list, although if hardened all the way through, would be nearer other end.

Ease of machining, Table V, is an important item when intricate patterns have to be made, or when dies of the same kind are being turned out. There is little difference in this characteristic between the first two (carbon and carbon-vanadium and manganese oil-hardening) but other four are tougher to machine.

TABLE I

MODERN DIE STEELS FOR COLD WORK

Water Hardening:	Straight Carbon
	Carbon Vanadium
Oil Hardening:	Manganese Oil Hardening
	1% Manganese Type
	1½% Manganese Type
	High-Carbon High-Chromium
	(2.2% Carbon)
Air Hardening:	Manganese-Chromium-Molybdenum
	5% Chromium-1% Molybdenum
	High-Carbon High-Chromium
	(1½% Carbon)

TABLE II

ORDER OF DISTORTION TENDENCIES OF DIE STEELS

	Decreasing Distortion ↓	
Straight Carbon		
Carbon Vanadium		
Manganese Oil-Hardening		
5% Chromium-1% Molybdenum		
Oil-Hardening High-Carbon High-Chromium		
Air-Hardening High-Carbon High-Chromium		
Manganese-Chromium-Molybdenum Air-Hardening		
↑ Increasing Distortion		

TABLE IV

RELATIVE TOUGHNESS OF DIE STEELS

	Decreasing Toughness ↓	
Carbon-Vanadium		
Straight Carbon		
5% Chromium-1% Molybdenum		
Manganese-Chromium-Molybdenum Air-Hardening		
Manganese Oil-Hardening		
Air-Hardening High-Carbon High-Chromium		
Oil-Hardening High-Carbon High-Chromium		
↑ Increasing Toughness		

TABLE III

COMPARATIVE WEAR RESISTANCE OF DIE STEELS

	Decreasing Resistance ↓	
Oil-Hardening High-Carbon High-Chromium		
Air-Hardening High-Carbon High-Chromium		
5% Chromium-1% Molybdenum		
Manganese-Chromium-Molybdenum Air-Hardening		
Manganese Oil-Hardening		
Carbon and Carbon - Vanadium		
↑ Increasing Resistance		

TABLE V

RELATIVE EASE OF MACHINING OF DIE STEELS

	More Difficult to Machine ↓	
Carbon and Carbon-Vanadium		
Manganese Oil-Hardening		
5% Chromium-1% Molybdenum		
Manganese-Chromium-Molybdenum Air-Hardening		
Air-Hardening High-Carbon High-Chromium		
Oil-Hardening High-Carbon High-Chromium		
↑ Easier to Machine		

Lime Ferritic Electrodes

(Continued from Page 97)

caused by an unbalancing of the slag and weld metal due to high sulphur. Mechanism of "red shortness" is explained as follows:

Iron sulphide forms films or cell walls around the grains of the metal. The sulphide fuses at red heat, each grain becoming surrounded by liquid iron sulphide which interrupts the solid continuity of the steel. Such discontinuous metal, when subjected to the cooling stresses normally encountered by freezing weld metal, is hot short and cracks. Fortunately the lime-ferritic coating purifies the sulphur contaminated weld metal and prevents hot shortness.

Steel foundries are making use of all modern metallurgical and inspection tools to provide carbon and alloy steel castings of excellent soundness and well balanced mechanical properties. Heat treatments are devised to produce high tensile strengths with good ductilities. X-ray inspection was adopted to improve casting practices and to prove the soundness of weld deposits. Use of lime-ferritic welding electrodes is increasing because they produce a more gas-free deposit for the repair and fabrication of castings. In castings for railroad service where quality demands are severe, alloyed types of lime-ferritic weld metal match the physical properties of heat treated castings and equal the sound metal of the casting itself when subjected to x-ray inspection.

Welded fabrication prior to enameling was not always successful. Because

of dissolved gas, probably hydrogen, the enamel would spall and chip over the welded area. In some instances enamellers were forced to give up welded fabrication because of excessive work spoilage. Lime-ferritic weld metal demonstrated an excellent response to enameling which will increase the use of welding in this field.

Of course there are many electrode types suitable for welding cast iron. Because of the excellent record established by lime-ferritic weld deposits on high carbon steels, it was only natural that these electrodes be tried on cast iron. Successful results achieved proved this.

Lime-Ferritic Electrode Properties

At this point it seems desirable to present the properties of lime-ferritic electrodes. The heavy coating used on them is of a lime stainless steel variety in which the principal ingredients are calcium carbonate and calcium fluoride, together with the customary slag forming and deoxidizing chemicals. Coating materials are held together and bound to the core wire with the usual alkaline silicates. Containing no organic materials, the coating would be classified as an all mineral type.

Usable current ranges deserve particular attention. The new electrodes are characterized by an extremely stable arc. Unfortunately, this unusually good arc stability sometimes leads welders to choose a welding current that is too low. At very low currents, weld deposits are likely to contain trapped gas which shows up in the final exographs. On the other hand, current values that are too

high may lead to excessive dilution of the weld deposit by the base metal. In the case of high carbon and alloy materials, such dilution may have a detrimental effect on ductility values. Experience shows that the current ranges given in Table I produce the best physical properties combined with the most sound welds.

Lime-ferritic electrodes should be used with direct current, reverse polarity for the best results. Some applications, however, have been made with alternating current where the results were quite acceptable.

Although lime-ferritic electrodes are primarily designed for welding in flat and horizontal positions, the 5/32-in. and smaller diameters are applied in the vertical and overhead positions. Because of the heavy coating which results in a thick slag, special welding techniques are necessary for out-of-position welding. Required techniques are taught to average welders in a rather short period of time, and the finished out-of-position welds exhibit a smooth uniform ripple with a flat to slightly convex contour.

Flat position welding in grooves leads to bead shapes that vary from a flat or even slightly concave contour to a definitely convex contour for cover beads or overlay beads. Welding techniques and the amount of current employed combine to influence the shape of the bead. The same factors are at work when horizontal fillet welds are made, the finished welds being flat to very slightly convex.

Arc action is quite smooth and steady. Penetration would be considered rather shallow and this point further favors the welding of the "difficult-to-weld" materials. The soft arc is characteristic of the stainless steel type of coating.

Slag blankets the weld deposit completely and may be removed quite easily. In either groove or fillet welds, customary hand chipping tools remove slag with very little work comparing quite favorably in this regard with E6020 electrode slags.

An outstanding quality of the new electrode deposits is the almost complete freedom from spatter. In Table II are shown average spatter loss values for the several mild steel electrode types. For a better visualization of spatter losses, this data is presented in Fig. 1. Here it is seen that HTS spatter losses run from 1/8 to 1/4 of those encountered with any of the other E60XX grades.

Fig. 2 shows the difference in spatter between an E6010 electrode on the left and HTS on the right.

Having completed a general description of these electrodes covering their operational and general application characteristics, a review of the physical, de-

HYDRAULICALLY POWERED: On this industrial truck, flywheel of gasoline engine directly drives hydraulic pump whose output goes into a valve bank from which operator directs power for propulsion, lifting, tilting, and steering by means of push-pull cylinder. Manufactured by Howell Industrial Truck Co., Cleveland, truck has equal speeds forward and reverse, and needs no separate or conventional brakes since it is stopped as well as started by hydraulic power

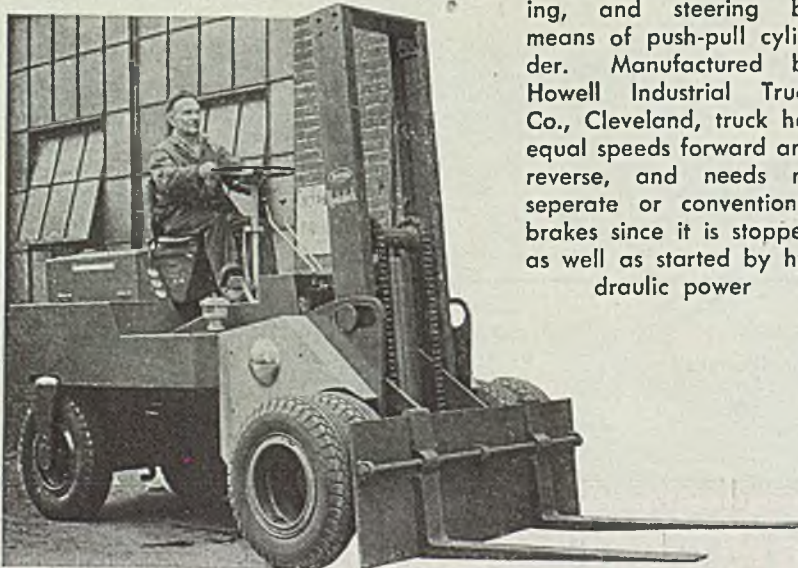

Performance Plus

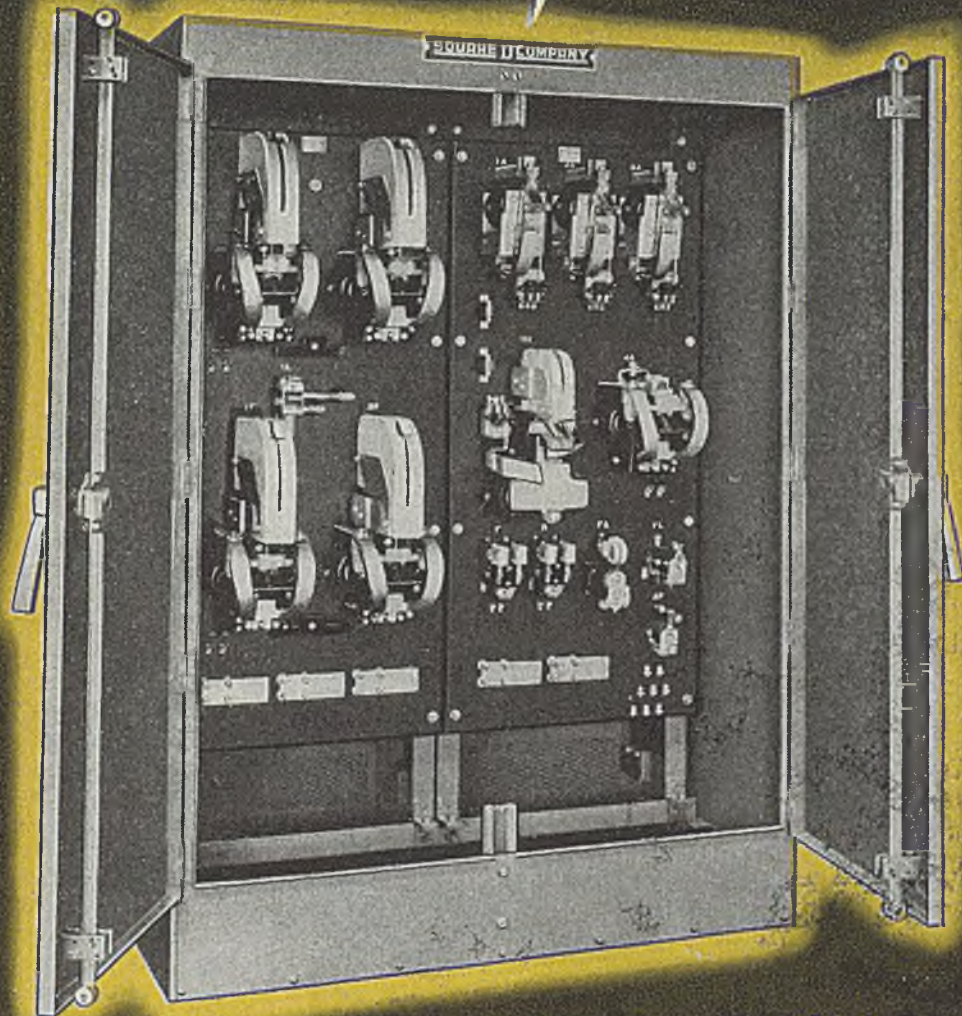

100 H. P. Reversing D. C. Magnetic Starter for Adjustable Speed Motor

with **SQUARE D D.C. Motor Control**

Generous wiring space and accessible terminals for fast installation. Simplicity of construction for easy inspection and maintenance. Appearance that reflects sound engineering and functional design. These are the things which this D.C. motor control offers—in addition to consistently outstanding performance.

Wherever electricity is distributed or controlled



SQUARE D COMPANY

DETROIT • MILWAUKEE • LOS ANGELES

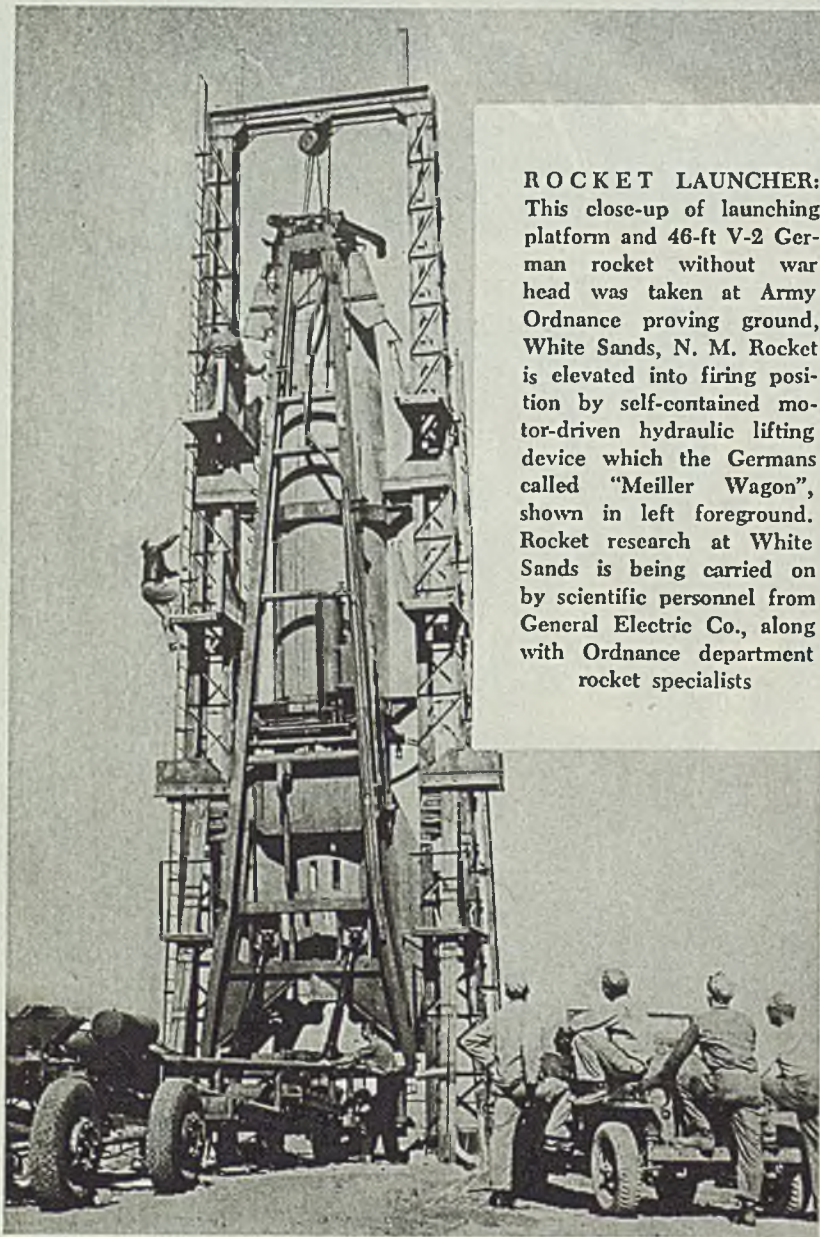

ROCKET LAUNCHER: This close-up of launching platform and 46-ft V-2 German rocket without war head was taken at Army Ordnance proving ground, White Sands, N. M. Rocket is elevated into firing position by self-contained motor-driven hydraulic lifting device which the Germans called "Meiller Wagon", shown in left foreground. Rocket research at White Sands is being carried on by scientific personnel from General Electric Co., along with Ordnance department rocket specialists

position, chemical and x-ray qualities will be undertaken next. Notwithstanding the fact that lime-ferritic electrodes do not fall into any specific AWS-ASTM electrode classification, they would most likely qualify in the E60XX group. Physical properties certainly meet the requirements of E6020 as may be seen in Table III where all of the as welded properties are reported. Almost without exception, the values shown for the as welded conditions meet the specification minimums for stress-relieved specimens produced with E6020 electrodes which have been the highest quality type in the E60XX group. The unusual ductility values of lime-ferritic deposits as demonstrated by elongation and reduction of area values unquestionably contribute to the crack-free welds made on steels with limited inherent weldability.

In Table IV, the effect of stress relieving is shown with the customary lowering of tensile properties and raising of ductility indices being found.

Although no proper classification of lime-ferritic electrodes under the AWS-ASTM system was attempted, the quality of the deposited weld metal, both physical properties and x-rays, compare quite favorably with the E6020 grade. Moreover, the all-mineral composition of the coating and the heavy slag formed during welding would also tend to favor a classification close to E6020. The all-position attributes of the small diameters, even considering the special techniques required, appear to bring these electrodes somewhat in line with E6010 requirements. In the last analysis, however, lime-ferritic electrodes are a distinctly different type. They do not properly belong in any established grade

classification but suggest the establishment of a new grade. In order that a ready comparison may be made among the deposition characteristics and physical properties of the new electrodes with grades E6010 and E6020, complete data are reported in Table V.

It is seen that the deposition factors vary because each electrode was used at a current which progressively increases from E6010 to type HTS to E6020. If the deposition rate in ounces per hour is considered on the basis of ounces per hour per 100 amp of current, the respective values become 33.0, 34.6 and 31.6. The differences in voltage are quite pronounced and confirm the recommendation for holding a short arc with the lime-ferritic electrodes. The heaviest coating of any electrode in the group will be found on the HTS electrodes, yet the deposition efficiency is better than that of the E6020 grade. This difference becomes apparent when spatter losses are taken into consideration.

Chemical Analysis of Weld Metal

Table VI shows the chemical analysis of weld metal deposited by the new electrode. Chips were taken from a five layer pad in the usual manner. It is seen that the deposit is essentially low carbon with normal amounts of phosphorus and sulphur, while the manganese and silicon contents may provide a partial explanation of the strength of the deposits.

Perfect x-ray sound welds may be made with these electrodes. Techniques at the change of electrodes are exceedingly important if porosity in the weld deposit is to be avoided. The arc should be struck within an inch of the preceding crater and moved backward to the center of that crater. If done correctly, the welder picks up and maintains a molten pool that completely melts any unfused or porous metal at the point where the arc was started. This procedure is designed to eliminate porosity at the beginning of the bead deposited from a new electrode. Best x-ray deposits are obtained when the shortest possible arc is maintained and when the current is near the upper end of the allowable range. In fact position and horizontal fillet welding procedures of this nature are easily established.

Rod Selector Chart

Bonding and remelting temperature is given for each of the company's welding alloys in the rod selector chart being distributed by Eutectic Welding Alloys Corp., 40 Worth street, New York. Brinell hardness and strength in pounds per square inch of these low temperature alloys also are given, along with factual welding information.

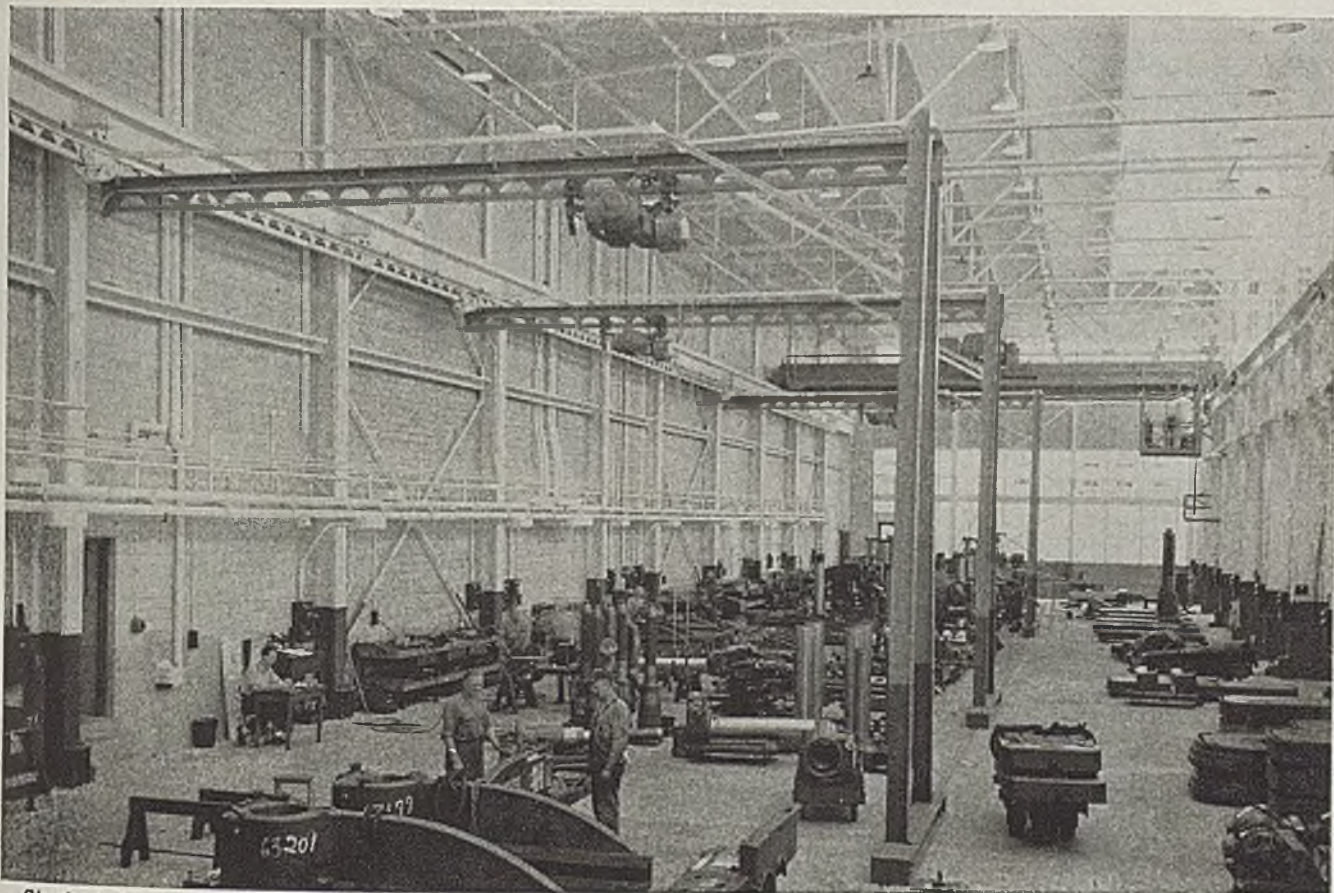

Single bridge, hand-propelled gantries with electric hoists operating under heavy overhead crane in a machine tool plant.

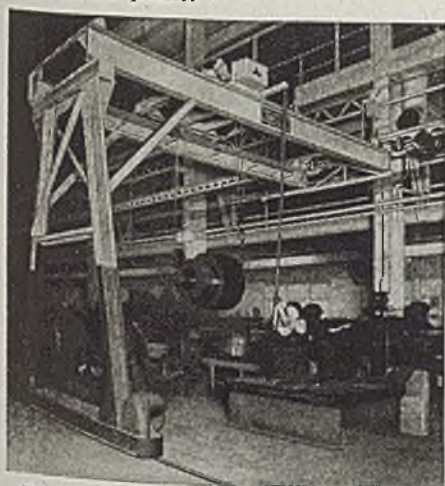

Double girder, completely motorized gantry. Because gantries ride on a floor rail and one wall rail, their use often eliminates need of long span overhead cranes.

GANTRY CRANES BOOST PRODUCTION

It is not unusual for skilled workers to wait 5 or 10 minutes and more in many shops for crane service. By providing a sufficient number of gantry cranes, much or all of this lost time can be eliminated and production aided.

Efficiency usually can be greatly improved by providing one large overhead crane for each shop bay — for the heavy lifting and transportation from one end of bay to the other — and a number of gantries to work under it, to do the light local or spot handling.

Several Cleveland Tramrail gantries generally can be purchased for the price of a large overhead crane and are available for manual or electric operation.



GET THIS BOOK!

BOOKLET No. 2008. Packed with valuable information. Profusely illustrated. Write for free copy.

CLEVELAND TRAMRAIL DIVISION
THE CLEVELAND CRANE & ENGINEERING CO.
 1125 EAST 283RD ST. WICKLIFFE, OHIO.

CLEVELAND  **TRAMRAIL**
OVERHEAD MATERIALS HANDLING EQUIPMENT

Pipemaker Starts

Large Improvement Program

By JOHN D. KNOX
Steel Plant Editor, STEEL

Works of National Tube Co. at Lorain, O., is being augmented by the installation of new by-product coke ovens, bessemer plant, soaking pits, blooming, bar, seamless and butt-weld rolling facilities and warehouse. Construction is proceeding without interfering with present operations

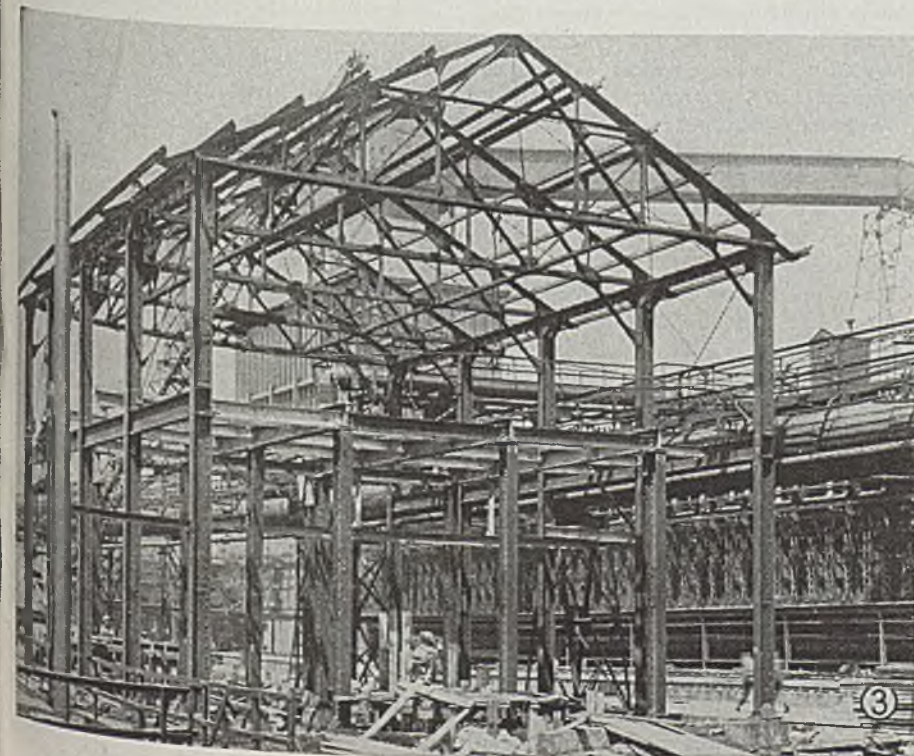
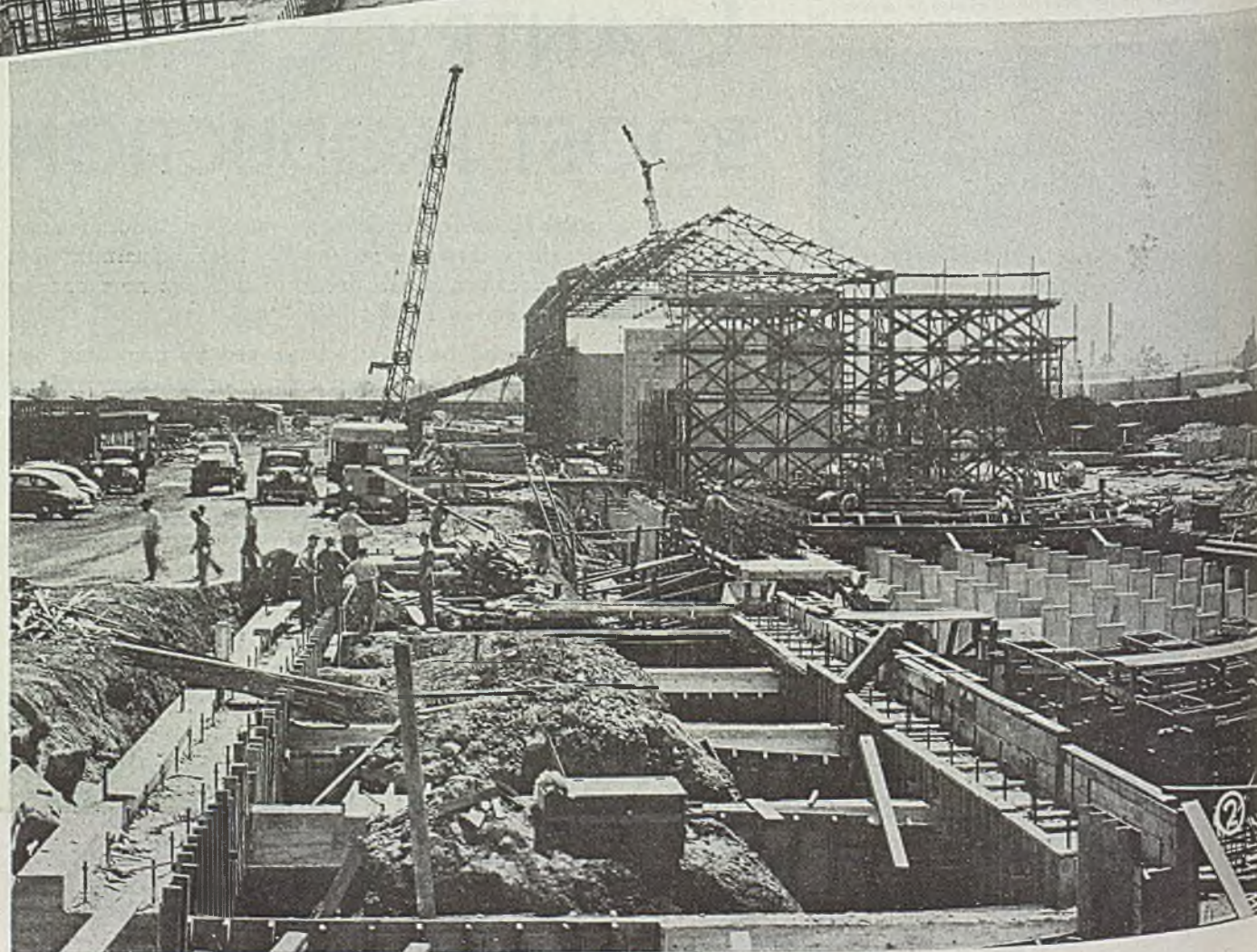
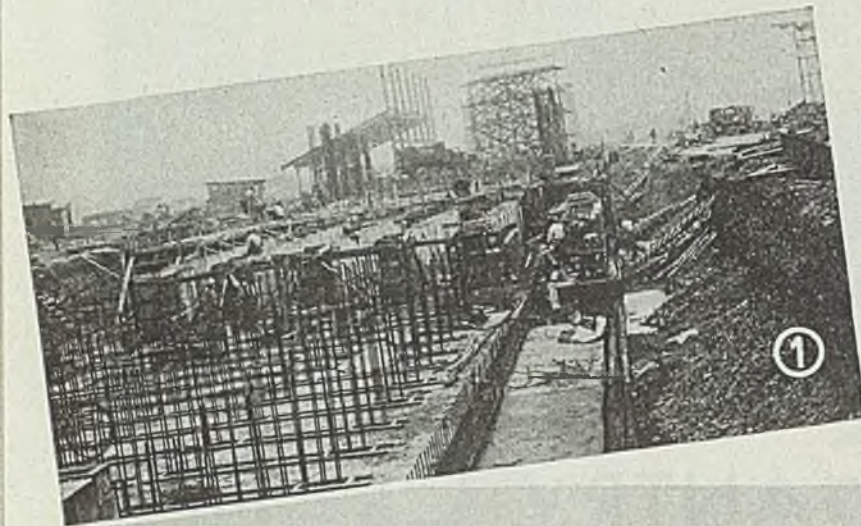

Fig. 1—Foundation work for new by-product coke ovens, looking east

Fig. 2—General view of coke oven construction work. Framework in background is temporary building to protect masonry; it later will be completely dismantled

Fig. 3—Framework of building which is to house new coke testing laboratory

EXPANSION at the plant of United States Steel's National Tube Co., Lorain, O., is on a much larger scale than is generally realized. While a guest at the plant recently I had the privilege of visiting the project offices where the various improvements and enlargements are in blue print form and where specifications for equipment are being written. Busy draftsmen are bending over their boards, civil engineers are out on the jobs with their transits and rods, men, contractors have set up their field offices in various parts of the plant with the names of their companies prominently displayed, bulldozers are moving tons and tons of earth, concrete pads and foundations are being poured literally by the tons and structural ironworkers are starting their jobs where progress permits.

The entire Lorain Works of National Tube comprises about 1410 acres on which are now located 208 by-product coke ovens, five blast furnaces, 12 open hearths, two bessemer, and various rolling mills including three bloomers, a rail and bar mill and two skelp, five butt-weld and three seamless tube mills. At present 177 Wilputte jet underfired ovens are under construction and a modern pipe warehouse is taking shape. Three modern bessemer vessels will take the place of the two now in service, a new bloom-

ing, bar and billet mill will replace two existing bloomers and a combination 28-in., 3-stand rail mill. A new seamless tube mill will be installed at the U. S. Steel subsidiary company plant.

By-product Coke Ovens: Coal handling facilities including mixers and pulverizers are being enlarged. Present coal storage is to be extended 600 ft which will permit an increase of 60 per cent in the storage capacity. Incoming coal will be delivered by diesel locomotive to a rotary unloader which empties the cars into a hopper bin. From here the fuel goes either to stock pile or to the crusher. A 48-in. conveyor belt conveys the coal to Bradford breakers for pulverizing to a uniform size. From 75 to 80 per cent will pass through a 1/8-in. mesh screen. The present pulverizing plant will be revamped, modernized and increased in size to handle the increased capacity necessary for the new coking requirements.

Coal from the crusher and pulverizing plant is conveyed to the top of the mixer building where the storage capacity has been doubled. Here mixing methods will be modernized. For instance, Syntron feeders and weightometers are to be installed for controlling the coal mixing by weight from the four 500-ton bins. Two new belt conveyors are being placed to enable coal to be fed into the existing coal bins and also into a new 4000-ton coal bin which will serve the new ovens. These bins are located over the ovens and feed through automatic motor-driven gates into the larry cars which charge the fuel into the ovens.

The three batteries of 59 ovens each are of the Wilputte type, jet underfired and designed to burn blast furnace gas. Passage from the old to the new batteries will be by way of a pedestrian tunnel which will have several outlets to the yard. Beneath the ovens will be an air circulating system to provide greater comfort for the employees. A tunnel will run the full length of the batteries along one side. Primary air is pulled into this tunnel and is then drawn across underneath the ovens to the opposite side where it passes through louvers, into the burners and thence

August 19, 1946

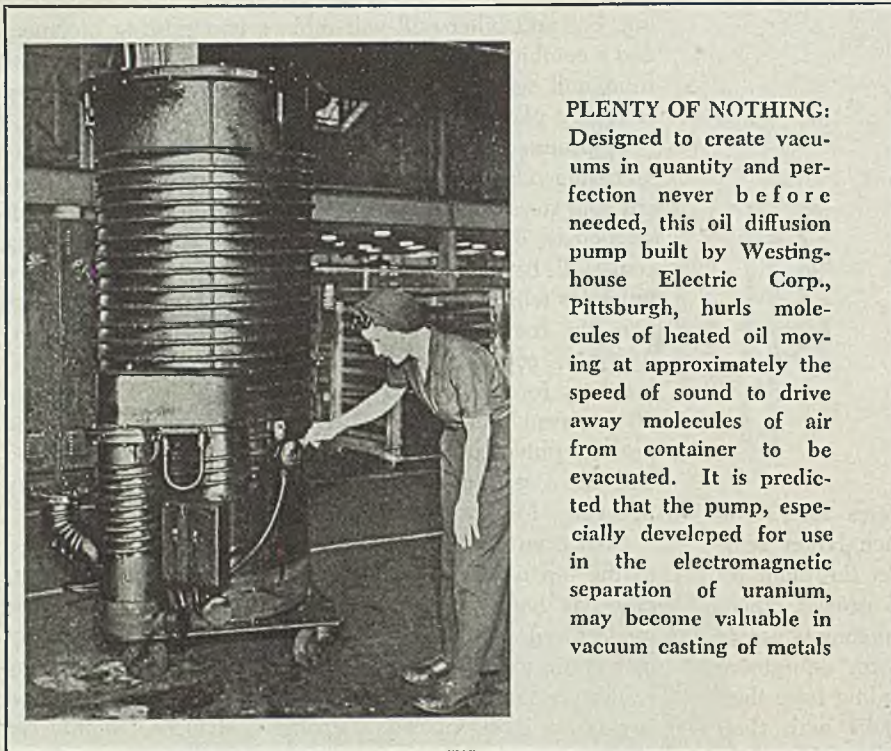

PLENTY OF NOTHING: Designed to create vacuums in quantity and perfection never before needed, this oil diffusion pump built by Westinghouse Electric Corp., Pittsburgh, hurls molecules of heated oil moving at approximately the speed of sound to drive away molecules of air from container to be evacuated. It is predicted that the pump, especially developed for use in the electromagnetic separation of uranium, may become valuable in vacuum casting of metals

to the stack of the ovens.

Coke from the ovens is pushed into a quench car which conveys it to the quenching station. Following the quenching operation the car returns to the coke wharf and dumps its load. From the wharf the coke will be fed onto a 48-in. conveyor to a cross conveyor and thence on to a 60-in. conveyor which discharges into the new sizing and screening station. Here the coke is screened into furnace, domestic, pea, breeze and dust grades. The furnace and domestic sizes are loaded in cars for the blast furnaces; breeze, pea and dust are used as mixture in the boiler house. The dust also is used for making soaking pit bottoms.

Facilities also are provided for loading trucks. Then, too, benzol and by-product and cooling water facilities are being expanded accordingly.

Operating in conjunction with the new coke ovens will be a modern coal and coke testing oven in a new laboratory.

Bessemer Improvements: Present bessemer steel capacity at the Lorain plant totals 594,000 net tons annually, this being supplied by two 12-ton vessels. These will continue to operate until the new bessemer plant is completed. This will include three active and one spare 25-ton vessels which will provide 1,350,000 net tons of bessemer metal a year.

The new plant will be located 1300 ft west of the old bessemer building. Each vessel will be of the eccentric type, bottom blown by individual turboblowers. Each steam-driven unit will deliver 40,000 cfm at 40 psi. Hot metal from two new 800-ton cylindrical-type mixers will be delivered to the vessels by a 35-ton

electrically-operated transfer car. Blown metal is poured into a ladle positioned at ground level and is transferred to the pouring building by a diesel locomotive. Here it is poured into molds and later charged as ingots in the new soaking pits.

Soaking Pits: Eight 3-hole blocks of soaking pits will be housed in a building 100 x 450 ft. These will be heated either by mixed gas, or straight coke oven gas. Their rated capacity will be 160,000 net tons per month. The pits are built at right angles to the end of the new blooming mill building to provide for future expansion and are so arranged that heated ingots can be delivered to the new 46-in. blooming mill as well as the existing No. 3 38-in. blooming mill.

Existing rolling facilities include No. 1 blooming mill installed in 1895, No. 2 blooming mill installed in 1898, No. 3 blooming mill installed in 1917, a 32-in. bar mill installed in 1928, and a 28-in. rail mill installed in 1894.

A complete new rolling mill unit will be installed including a 46-in. blooming mill, a 38-in. bar mill, a 32/26-in. billet mill and a 20-in. bar mill. Existing rolling facilities will not be disturbed by the new construction, but once the new equipment is in operation, then Nos. 1 and 2 bloomers and the rail mill will be abandoned. No. 3 bloomer and the 32-in. bar mill, now scheduled on various size tube rounds, will be free to concentrate on the production of tube rounds over 8-in. diameter once the new plant is in service.

The new 46-in. blooming mill will be powered with a twin drive and will be able to convert 32½ x 32-in. ingots

weighing approximately 22,890 lb.

The 38-in. bar mill is of the reversing type and is designed to roll rounds 7-in. diameter and larger. A hot scarfing machine is to be located after the bar mill for surface preparation of the steel when necessary.

The 32/26-in. continuous billet mill comprises three stands each of 32-in. vertical rolls and 26-in. horizontal rolls. A parting saw is located just ahead of the mill for cutting semifinished material to the proper size for converting to small rounds.

A feature of this mill is that it will operate without twist guides. Another feature is to be found at the finishing end. Here the rounds are cut into double length blanks for the seamless tube mill, centered at both ends and then sawed in two pieces. Thus it is apparent a centering operation is eliminated by this arrangement compared to conventional methods. Flexibility also has been woven into the layout. If for any reason this mill is down, the semifinished steel from the bloomer can be by-passed and finished off on the 4-stand 20-in. mill just beyond and to one side.

The mill will roll tube rounds, 8 in. and under, and billets and slabs which later will be converted to skelp for the butt weld mills.

The 20-in. mill is built with two stands of vertical rolls and two stands of horizontal rolls for the production of 3-in. rounds and bars as well as billets down to 2½ x 2½-in. in 30 ft lengths for outside shipment. Finishing ends of the new mills are so located that materials can be taken away quickly either on skids, piling racks or railroad cars for outside shipment or on standard gage cars for intermill requirements. Wherever possible, individual drives on roll stands have been employed. Scale from the roll stands is handled by a sluice system. All crops are handled by skip cars.

No. 4 Seamless Mill: This mill will have an annual capacity of 260,000 net tons. It will use two sizes of billets, namely 4¾ and 5¾-in. for the production of 2-in. OD standard pipe, up to 4½-in. OD, boiler tubes, and for the production of upset tubes.

Butt weld Mills: Present equipment includes five mills Nos. 2, 4, 6, and 7, for the production of butt weld pipe ½ to 3 in. diameters. Approximately half of the output is galvanized. These mills are being revamped. No. 7 mill, now a single length unit, is to be equipped with a double length furnace. A double length butt weld mill moved from another plant is to be augmented by new furnaces and finishing equipment. It was necessary to extend the cold beds at No. 5 skelp mill in order to take care of the

(Please turn to Page 150)

UNDIVIDED RESPONSIBILITY
IN ONE ORGANIZATION

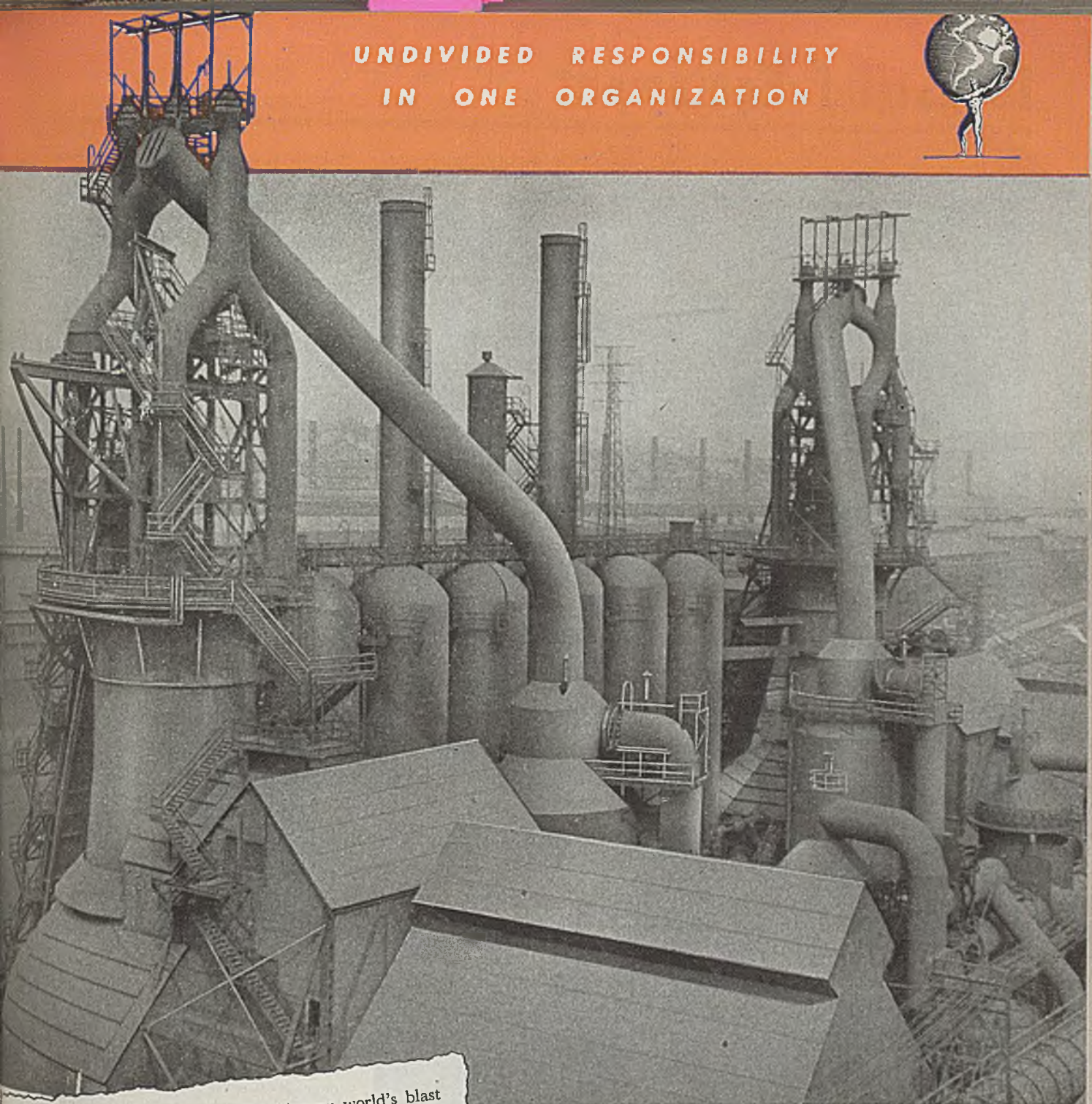

BLAST FURNACE RECORD — A new world's blast furnace record was made in July by the No. 2 blast furnace at the Edgar Thomson Works of Carnegie-Illinois Steel Corp., with a production for the month of 50,590 tons. The previous record was held by Great Lakes Steel Corp., which has a furnace that produced 49,705 tons in 1943. The new record is more unusual because it was made without scrap charges, according to the company. In making the new monthly record, the furnace set two new weekly records and a daily record. The best weekly record was for the week ending July 26, when 12,189 tons of pig iron were produced and the best daily record was made on July 12, when the output totaled 1976 tons or 48 pct over the 1350 ton rated capacity of the unit. The monthly production was 23 pct over the rated capacity of the furnace.

REPRINTED FROM IRON AGE, AUG. 9, 1945

THE photograph reproduced above shows the No. 1 and No. 2 blast furnaces at the Edgar Thomson Works of Carnegie-Illinois Steel Corporation. These furnaces were designed and constructed during the war by Arthur G. McKee & Company. The record referred to in the clipping was made by the No. 2 furnace shown at left.



Arthur G. McKee & Company

★ *Engineers and Contractors* ★

2300 CHESTER AVENUE · CLEVELAND, OHIO

ROCKEFELLER PLAZA
NEW YORK, N. Y.

MCCORMICK BUILDING
CHICAGO, ILLINOIS

Industrial Equipment

Air Valve

An automatic air valve built to speed up air cylinder travel per minute is a product of Bryant Products Co., Jackson, Mich. Valve lets air into cylinder

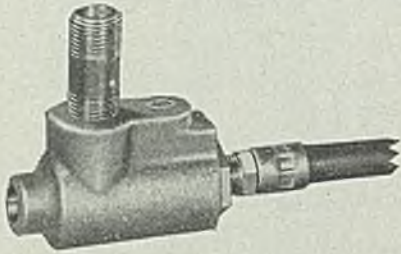

and, when operated, it automatically opens a port at cylinder for exhaust.

Valve speeds up cylinders from 50 to 200 per cent depending on how far operating valve is from cylinder.
Steel 8/19/46; Item No. 9576

Thread Milling Machine

Six self-contained, independent work stations are mounted on a circular bed with variable rotary feed in the rotary thread milling machine designed by Cross Co., Detroit 7. Feed is timed so each station automatically completes milling on one piece of work during one revolution of bed past operator's station. Function of operator is to unload and reload pieces as stations pass him and then push button to repeat automatic cycle.

In this cycle, motor-driven milling head approaches cutting position quickly.

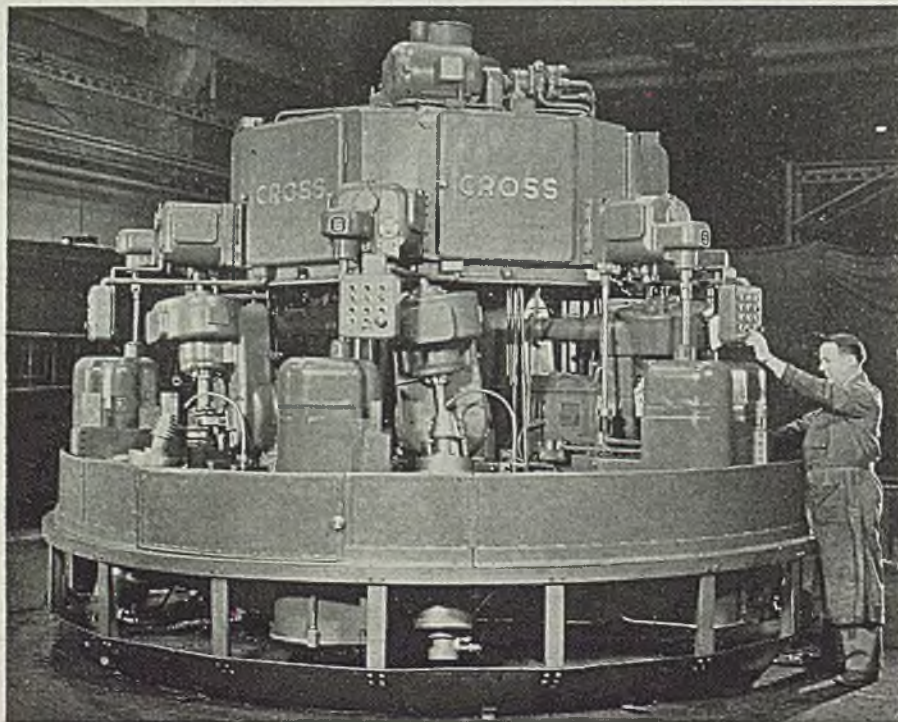

(All claims are those of respective manufacturers; for additional information fill in and return the coupon on page 140.)

With the cutter turning, work head spindle spiral-feeds piece upward into cutter. Upon completion of the cut, milling head moves back to idle position, and workhead lowers while the spindle reverses.

Steel 8/19/46; Item No. 9479

Drum Type Calculator

Scales for accelerated calculation of spectrographic analysis are prepared and used on Dunn Lowry drum calculator manufactured by Harry W. Dietert Co., 9330 Roselawn avenue, Detroit 4, and Applied Research Laboratories, 4336 San Fernando road, Glendale 4, Calif. Calculator as shown consists of a board for

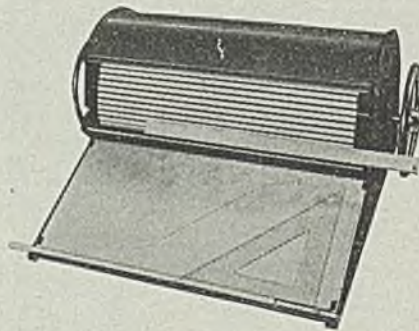

plotting curves, and a large rotary drum which carries analytical scales.

Relative intensity is determined or measured by means of a movable horizontal logarithmic scale at the bottom. The 2 cycle scale, 12 in. per cycle, is 24 in. long. Usual vertical scale for plotting the per cent transmission is a loga-

rithmic scale projected on hypotenuse of a 45 degree triangle. Film calibration curve, with length of over 24 in., is drawn on graph paper, using log scales.

Calibration curve is used to determine intensity ratios, and these are plotted to give analytical working curves. Vertical projections of these curves are made directly with pencil or pen on sliding strips for the drum.

Steel 8/19/46; Item No. 9496

Marking Machine

Model E P-1 bench marking machine, a hand operated machine which can be easily tooled for marking pieces of varied sizes and shapes, is latest development of Edward Pryor & Son Ltd., Sheffield, England, represented by Wm. A. Force & Co., 216 Nichols avenue, Brooklyn 8, N. Y.

A hand lever embodied on the machine draws carriage to which marking

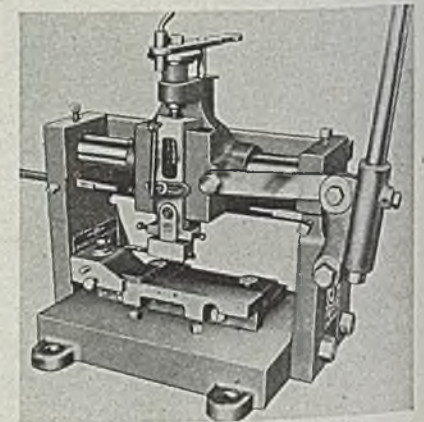

die is attached along a round slide bar. Both flat and cylindrical work can be marked on either top of a small angle plate, or directly on machine base plate. Length of inscription made by machine depends on depth of impression required, kind of material and size of characters. Generally, 2 in. on steel and 3 in. on brass are outside limits.

Steel 8/19/46; Item No. 9515

Transfer Valve

A manually or automatically operated 125-lb single vane, control valve is used to transfer chemicals, oil, water and other materials from one line to another. Manufactured by H-S Products Corp., Wayne Junction, Philadelphia 44, it is offered for a wide range in pressure together with operation at subzero and elevated temperatures.

Valve is equipped with adjustable stop screws and indicator to determine vane position. Body of the valve is

Strides in Steelmaking

By WISCONSIN

• Two great strides in steelmaking are *Sulfite-Treated Steel*, the more machinable steel, and "*H*" Steels, alloy steels of guaranteed hardenability.

Sulfite-Treated Steel, originated and developed by Wisconsin metallurgists, has proven itself to be far more machinable than ordinary steel even after being hardened by heat-treatment. Yet its physical properties are entirely satisfactory. In every application where machinability counts, increased production and lowered costs have been the result.

"H" Steels are alloy steels produced to your "product prescription." This means that "H" Steels have a much narrower hardenability band *guaranteed*. Wisconsin has been a leader in the development of these steels and at present is the largest producer of "H" Alloy Steels.

Wisconsin's completely integrated operations from ore and coal mines to the finished steel, staffed by top-flight steelmakers, are your assurance of excellence in alloy and special steels. Our sales and metallurgical staffs are at your service.

WISCONSIN STEEL COMPANY
(Affiliate of International Harvester Company)
180 North Michigan Avenue Chicago 1, Illinois

WISCONSIN STEEL OPERATIONS

IRON ORE MINES COAL MINES OPEN HEARTH FURNACES
HEAT-TREATING, COLD FINISHING AND ANNEALING FACILITIES
ROLLING MILLS ORE FREIGHTERS BLAST FURNACES

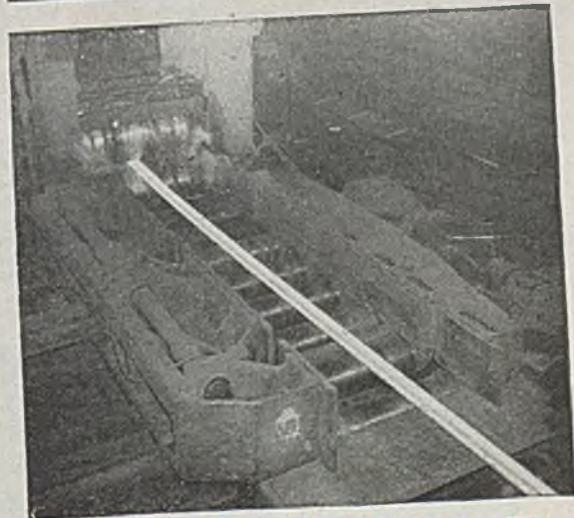
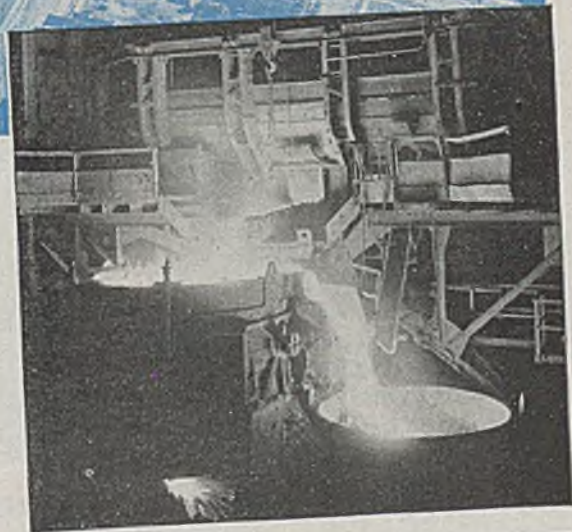

WISCONSIN STEEL

TWENTY WAYS TO DO GRINDING JOBS BETTER AND FASTER!

STERLING'S STERMOUNTS offer positive solutions for your perplexing, difficult grinding and polishing jobs. The twenty shown to the right are but a few of many shapes and sizes which are available to use in those hard-to-get-at locations where good grinding seems impossible.

Sterling's Stermounts are made in both vitrified and resinoid bonds to widen their usefulness for grinding all types of metals . . . they have the correct outlines to fit into all types of holes and recesses.

Sterling's Stermounts have the added advantage of removable spindles that can be used over and over again. These spindles are made in two sizes to add extra rigidity and safety to the Stermounts when they are in use.

Sterling's Stermounts hold their cutting qualities and do a quick job on all kinds of metals without undue pressure being exerted. They are sturdy and tough . . . provide long grinding life.

Want to cut costs with Stermount? Drop us a line today, and we will tell you how to do it.

"THE
WHEELS
OF
INDUSTRY"

Sterling

• The complete Stermount line of wheels and shapes is shown in this attractive folder which is available for distribution. Send for your copy . . . it gives measurements and prices of each type . . . describes the spindles, tool



• STERLING ABRASIVES •

THE
STERLING GRINDING WHEEL DIVISION
OF THE CLEVELAND QUARRIES COMPANY
TIFFIN, OHIO

THE WHEELS OF INDUSTRY

constructed of "A" metal, a tough, dense metal of uniform grain and high endurance limit. It resists galling, "wire drawing" and wearing action of abrasive materials.

Steel 8/19/46; Item No. 9510

Drum Truck-Rack

Combination truck-rack for carrying and storing 55-gal drums, is announced by Aircraft Mechanics Inc., Colorado Springs, Colo. Called the Super-Toter, the tubular steel truck-rack is easily loaded by one man. Wheel unit is designed to swing so that actual lifting of drum is delayed

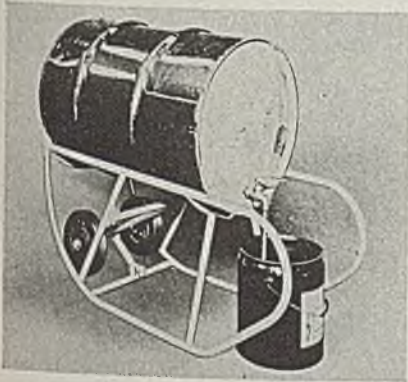

until entire weight is balanced over wheels.

Assembly features a detachable wheel unit which can serve many racks, if desired, attaching or detaching so that a series of racks may be used intermittently as pouring stands or drum trucks.

Steel 8/19/46; Item No. 9493

Frequency Meter

New development of Communication Measurements Laboratory, 120 Greenwich street, New York 6, is a device for measuring frequency of alternating current voltages over the entire audible frequency



spectrum. In conjunction with a photo-beam converter, model 1800 becomes an electronic tachometer for measuring speed of rotating or reciprocal mechanisms, including those which cannot be subjected to any additional mechanical load. It measures speeds in excess of one million revolutions or cycles per minute.

Accuracy of instrument is unaffected by line-voltage variations of 105 to 125

v or by temperature variations from 0° C to plus 70° C. Used with two photo-beam converters, it can be used in study of gear mesh, torque, and dynamic strain. Vibration rates can be measured by application of a pickup device to any stationary object subject to vibration.

Steel 8/19/46; Item No. 9487

Hydraulic Vise

Munton Mfg. Co., 9400 Belmont avenue, Franklin Park, Ill., announces two new hydraulic vises of 4 and 7-ton capacity for use with drill press, lathe, milling machine, grinding or for other jobs such as holding, berding, riveting, punching and assembling. Vise is operated by a foot treadle located on floor. Pressure remains constant until released by complementary foot treadle.

Made of semi-steel castings with hardened steel jaws and extended ways to resist wear, vise is self-air eliminating and never requires bleeding. Jaws open to 4 and 7 in. on two models.

Steel 8/19/46; Item No. 9372

Shaft Turning Machine

A center drive double end turning machine equipped with front and rear tool slides is announced by Snyder Tool & Engineering Co., 3400 East Lafayette, Detroit 7. Front slides are for turning various diameters and forming a taper on one end. Rear slides are for facing, chamfering or undercutting. Center drive of machine has three serrated jaws which grip part without deflection.

Machine operates at speeds necessary for cemented carbide cutting tools, production being from 90 to 100 cycles per hour at 80 per cent efficiency. Tool feed

is actuated hydraulically through an electrically-controlled time cycle.

Tailstock center being well out of way permits easy loading and is brought in hydraulically by means of a manually operated hydraulic valve. After loading machine, center drive is manually engaged through a clutch lever on the headstock and part is rotated.

Machine is equipped with four motors, one for headstock and rotation of work, two of equal capacity for hydraulic equipment and one for coolant pump. Base is welded steel and contains coolant trough and the chip pan.

Steel 8/19/46; Item No. 9468

Taper Inspection Plate

Taper inspection plate capable of checking many different types of tapered work, such as thread and plug gages, reamers, cutters, arbors and broaches, is offered by Ex-Cell-O Corp., Detroit 6. It con-

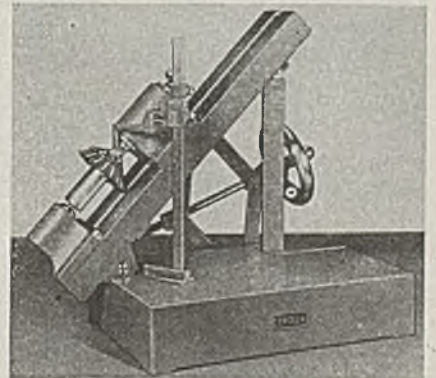

sists of a fixed sine bar carrying adjustable centers, with hand wheel for elevating and lowering. Gage or taper height blocks establish checking angle.

Fixed center carries a hardened block that is 90 degrees to line of centers,

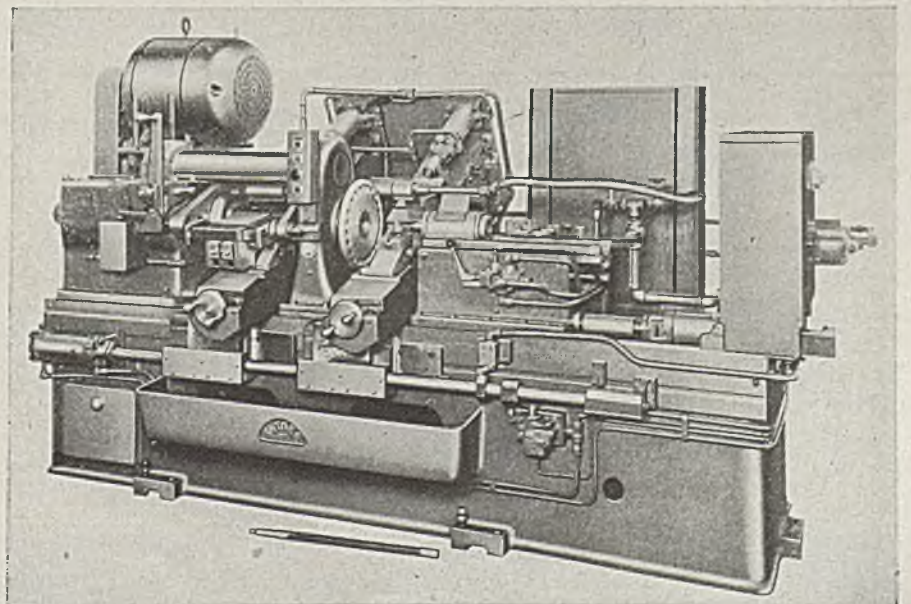

(All claims are those of respective manufacturers; for additional information fill in and return the coupon on page 140.)

INDUSTRIAL EQUIPMENT

permitting angles to be checked directly on face of sine bar, wedges, angle blocks, etc. Plate is adjustable for angles up to 45 degrees. Maximum length between centers is 12 in. and diameter between centers is 4 in. Size of surface plate base is 3¼ x 11 x 16½-in.
Steel 8/19/46; Item No. 9484

Pressure Relief Valve

Aerotec Co., White Plains, N. Y., has designed a pressure relief valve that maintains a predetermined pressure by relieving any excessive pressures that may take place in fuel and hydraulic lines. Valve can be set to desired pressure

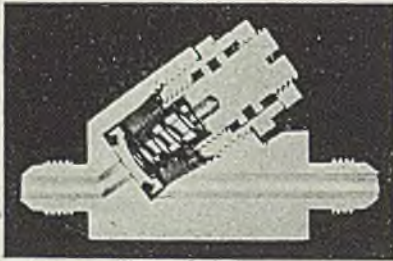

at anytime without interrupting its operation by means of an outside adjusting screw, eliminating necessity for disconnecting either inlet or outlet.

Valves are offered for pressures ranging from 5 to 100 psi in units having individual ranges of approximately 15 psi. Inlet and outlet are in a straight line.

Steel 8/19/46; Item No. 9549

Sand Core Face Grinder

Portable production machine for grinding sand core faces before pasting cores together to produce a uniform accuracy is latest product of D. J. Murray Mfg., Wausau, Wis.

Use of machine eliminates patching

broken joints and does not tear core edges. It handles a large range of core sizes and is furnished complete with 1-hp motor. Compact, it requires floor space of only 3 x 5 ft for operation.

Grinding head of the Murco, as the unit is called, is adjustable, and locks



firmly in any position. Small cores can be handled in multiples in gang fixtures during production runs. Maximum clearance between face of the unit's table and face of grinding wheel is 18 in.
Steel 8/19/46; Item No. 9590

Vibrating Oiler

An automatic vibrating rod bottle oiler for plain sleeve and line shaft bearings, jack shafts and spindles is announced by Oil-Rite Corp., 3466 South 13th Street, Milwaukee 7. Constructed of unbreakable Lucite and brass, the device feeds oil from airtight reservoir through an oilport to a feed rod which slides freely in a closely-fitted hole in base. Vibration is caused by directional drag of rotating shaft on feed rod.

As bearing becomes warm, heat is

conducted through rod to reserve oil, causing air to expand and force oil down feed rod to bearing. Airtight cap prevents dust, dirt and chips from getting into oil holes.

Capacities of 1/2, 1, 2, 4, 8, 16 and 32 oz are offered with 1/8, 1/4, 3/8 and 1/2-in. pipe thread.

Steel 8/19/46; Item No. 9459

Seat Grinder

An automatic motor-driven handhole seat grinder developed by Lagonda Division of Elliott Co., Springfield, O., provides fast and accurate resurfacing of handhole seats of all sizes and shapes. Unit is set up by threading a face plate to a handhole plate stud of an adjacent

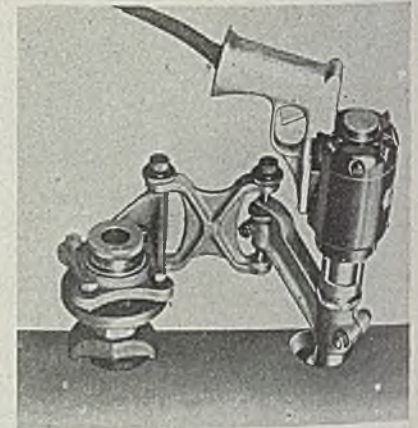

handhole. Plate controls alignment of grinding wheel relative to seat face.

End-play in clevis bearings of grinder is eliminated by adjustable point clevis bearing spindles. Width of seat to be ground is controlled by guide roller on spindle housing which bears against side of handhole. Handholes of any shape may be ground within 11½-in. or at greater distances by using an extension link.

Unit is driven by either air or electric

FOR MORE INFORMATION on the new products and equipment mentioned in this section, fill in this form and return to us. It will receive prompt attention.

Circle numbers below corresponding to those of items in which you are interested:

9576	9484	9481
9479	9519	9550
9496	9590	9116
9515	9459	9450
9510	9491	9483
9493	9486	9583
9487	9135	9189
9372	9520	9490
9468		9476

8-19-46

NAME..... TITLE.....

COMPANY.....

PRODUCTS MADE.....

STREET.....

CITY and ZONE..... STATE.....

Mail to: STEEL, Engineering Dept.—1213 West Third St., Cleveland 13, Ohio

(All claims are those of respective manufacturers; for additional information fill in and return the coupon on this page.)

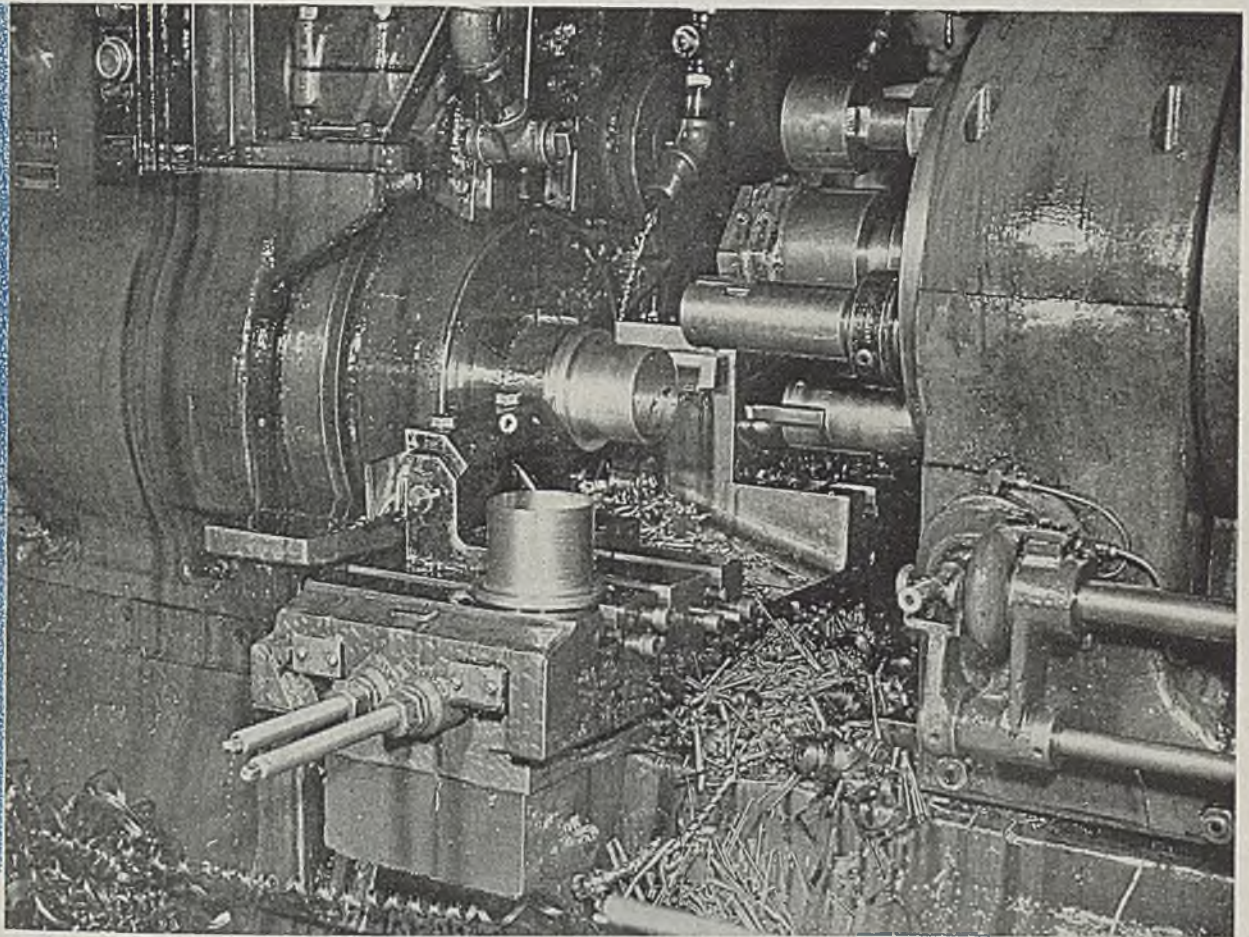

ONE SETUP ON A CLEVELAND AUTOMATIC DELIVERS THIS PART, IN 52100 STEEL

If you want to produce parts like this for profit, remember this simple setup on a Cleveland 5¼" Model A Automatic . . . STOCK: 4⅞" bars of 52100 steel . . . TOLERANCES: .003" overall . . . TOOLS: carbide, in five turret stations and two cross-slide mountings . . . SEQUENCE: 1 . . . Gauge stock; 2 . . . rough turn two diameters OD and centerdrill; 3 . . . rough out ID and flat bottom from turret and finish-form two ODs from rear cross-slide; 4 . . . rebores ID and finish flat bottom, start cutoff from front cross-slide; 5 . . . finish ream, complete cutoff. Part is delivered faster than by any method previously used. Machine automatically proceeds with next piece. A total of 16.9 lbs. of metal is removed. The 5¼" A is but one of the versatile Cleveland line, with capacities from ⅜" to 10" described in a new bulletin, available on request.

Just Remember . . . Cleavelands Cut Costs

CHICAGO (6):
1408H Civic Opera Bldg.
CINCINNATI (12):
4032H Beech St.
DETROIT (2):
540H New Center Bldg.
HARTFORD (1):
529H Capital National
Bank Bldg.
NEW YORK (6):
2402H Singer Bldg.

THE CLEVELAND AUTOMATIC MACHINE CO.

2279 Ashland Road

CLEVELAND 3, OHIO

motor. Illustration shows electric model at work on a round header with oval holes.

Steel 8/19/46; Item No. 9491

Pump Booster

New pump booster is announced which makes available heretofore inaccessible water supplies for fire fighting and permits water drainage from pits or cellars beyond reach of standard pumping equipment. The Accel-o-rate pump booster, manufactured by Jet Pump Division of Derbyshire Machine & Tool Co., 5218-J

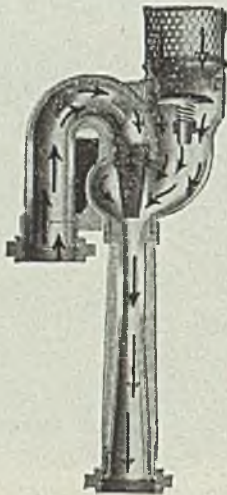

Belfield avenue, Philadelphia 44, will lift water vertically 100 ft or more, and will draft water for distances of 200 to 300 ft from water sources impossible to reach.

Employing jet pump principle, this unit has no moving parts, weighs 18 lb, and will not become clogged. Two 2½-in. soft hose lines, are run from pumper to booster which is submerged in water supply. When pumper takes suction after priming, driving water going through the jet entrains additional water which is returned to the suction side of pumper. This additional water is available for fire fighting. The size illustrated will supply adequately a ½-in. tip.
Steel 8/19/46; Item No. 9486

Mobile Coolant Filter

Mobile coolant filter designed to remove, filter and replace oils or coolants used in machine tool operations is announced by Honan-Crane Corp., 636 Wabash avenue, Lebanon, Ind. It operates directly on the machine tool sump by inserting a suction hose in back end of the sump. Flow from discharge hose is used to stir up and flush all abrasives and dirt back toward the suction hose.

The filter will clean up one machine in a few minutes. A removable expanded

metal basket inside retains chips, dirt and abrasives and can be emptied, washed in a degreaser and used again.

The unit has a suction flow rate of 10 to 20 gpm. It is mounted on 26-in. roller bearing steel wheels and a swivel, stands 64 in. high, is 60 in. long and 30 in. wide.

Steel 8/19/46; Item No. 9135

Recorder-Controller

An automatic recorder-controller for temperature and pressure is announced by C. J. Tagliabue division of Portable Products Corp., 600 Park avenue, Brooklyn 5, N. Y. Instrument requires only the push of a button to control processing completely from start to finish.

By use of an adjustable cam, timing starts automatically when temperature

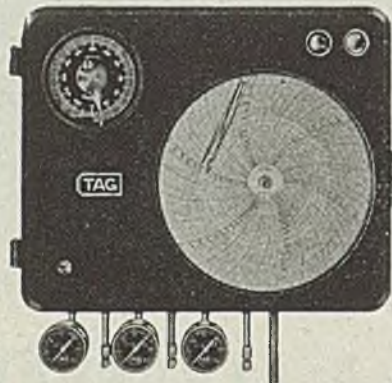

reaches processing point and is terminated at precisely desired moment. All valves, whether steam, air, water or overflow, are opened and closed as process may require without any manual attention.

A red light on controller shows steam-heating phase of process. When heating is completed and steam is shut off, red light is extinguished and a white light appears. After sufficient time for cooling, white light goes out, indicating visibly to operator that cycle is complete.

Steel 8/19/46; Item No. 9520

Level Control

Level Control series 10, developed by Photoswitch Inc., 77 Broadway, Cambridge 42, Mass., is suitable for control of water, ammonium chloride, copper nitrate, sulphate, sodium chloride, potassium hydroxide, and many other acids, bases, and salts.

Selection from four terminals on terminal block enables control to be matched to specific resistivity of a material. Probe rods are suspended in tank from probe fittings. Liquid to be controlled makes or breaks contact with probe and transmits to control a minute electrical current at low voltage which controls a power circuit which in turn operates a relay to

actuate signals, valves, or pumps. Instrument is operated on 150 or 230 v 60 or 60 cycle ac.

Steel 8/19/46; Item No. 9481

Testing Unit

Testing unit for heavy and large work which cannot be readily tested in any of the standard size rockwell hardness testers or rockwell superficial hardness testers is latest product of Wilson Me-

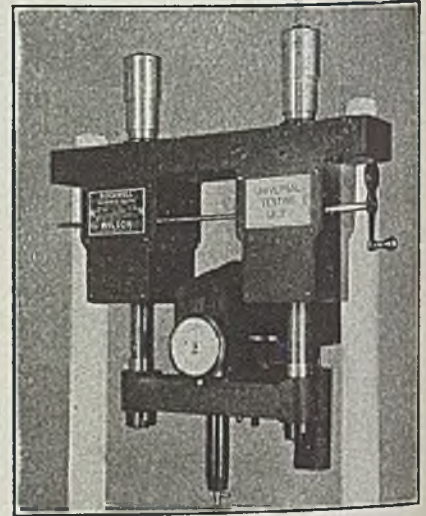

chanical Instrument Co. Inc., 383 Concord avenue, New York. This furnishes a testing unit for mounting in whatever design of rigid frame user builds to meet his testing needs.

Steel 8/19/46; Item No. 9550

Cutting Torch

The Gasweld featherweight cutting torch, manufactured by Wall Chemicals Division of Liquid Carbonic Corp., 3100 South Kedzie avenue, Chicago 23, is designed for light metal cutting, but can be used to cut heavier materials.

Weighing only 2 lb 2 oz it is only 16 in. from tip to butt of handle. It has a ribbed brass handle and tubes of nickel-copper alloy in triangle assembly. It is made with either 80 or 90 degree forged head and has a 1-piece tellurium copper tip.

Steel 8/19/46; Item No. 9416

Oxygen Impurity Tester

Oxygen and hydrogen impurities in gases may be detected and measured through the Deoxo indicator designed by Baker & Co. Inc., Newark, N. J. Capable of operating for long periods with little attention, instrument indicates presence of from 0.001 per cent to 1.0 per cent oxygen impurities.

Presence of small quantities of oxygen as an impurity in inert gases, CO₂, H₂,

(All claims are those of respective manufacturers; for additional information fill in and return the coupon on page 140.)



You're Sitting on a Lot of NEW MERCHANDISE!

The shortage of scrap metal, desperate during wartime, is still serious. The production of many of the things you need is being slowed up . . . will be interrupted unless steel mills continue to get a larger supply of scrap iron. More than half of the steel used in America requires scrap for its

production. Call your scrap metal dealer . . . gather and sell worn-out iron and steel of all types. This is necessary to help provide uninterrupted production of steel and things made of steel. Help speed delivery of many of the items on your *want list* . . . turn in your scrap today.

All Continental products are made from open hearth steel and are uniformly processed and finished according to the needs of their use. Increasing Continental production is "stepping up" shipments of steel sheets, wire, Chain Link fence, etc.

**CONTINENTAL
STEEL**

CONTINENTAL STEEL CORPORATION

GENERAL OFFICES • KOKOMO, INDIANA

PRODUCERS OF STEEL SHEETS, including
Continental GALVANIZED, COPPER-STEEL Gal-
vanized, KONIK steel sheets Galvanized,

UNIFORM SPANGLE Galvanized, DULL COAT,
Continental GALVANNEALED, ELECTRICAL, Hot
Rolled Pickled, and many styles of Formed Roofing.

ALSO, Manufacturer's Wire in many sizes,
shapes, tempers, and finishes, Continental Chain
Link Fence, Nails, and other steel products.

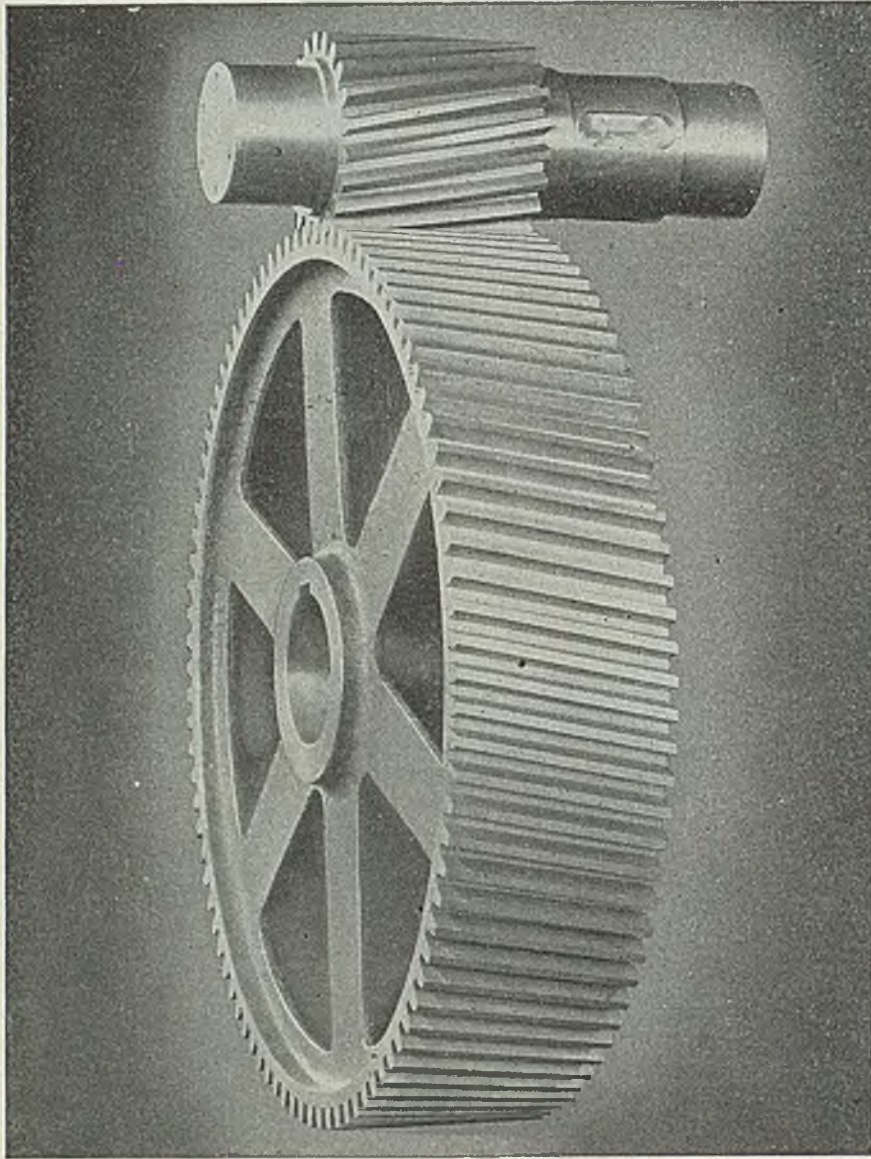

SMOOTH RUNNING HELICALS

★ Large or small . . . Horsburgh & Scott Helical Gears are doing a great job for industry because of their greater accuracy . . . greater resistance to wear. Six outstanding features make them most economical, quiet and smooth for transmitting power between parallel shafts . . . it will pay you to learn more about these popular Helicals.

Send note on Company Letterhead for 488-Page Catalog 41

THE HORSBURGH & SCOTT CO.

GEARS AND SPEED REDUCERS

5112 HAMILTON AVENUE • CLEVELAND, OHIO, U. S. A.

—INDUSTRIAL EQUIPMENT—

or saturated hydrocarbon gases, is detected and measured in indicator by increase in temperature of gas sample which results from combination of oxygen impurity with hydrogen.

Except where gas being tested already contains sufficient hydrogen, a small amount generated in an electrolytic cell is mixed with sample. After passing through a drying chamber and charcoal purifier sample enters a calorimeter, where during passage over catalyst, a combination of any oxygen with hydrogen is

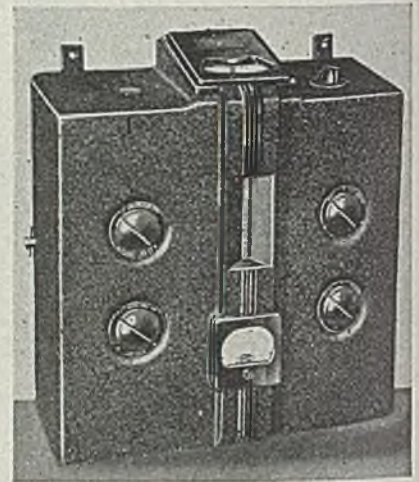

effected. Heat liberated is directly proportional to concentration of oxygen in sample.

A thermocouple indicates temperature rise in gas caused by reaction. Instrument may be modified to detect and measure small quantities of hydrogen impurity in other gases by means of a slight change in the electrolytic cell whereby excess quantity of oxygen instead of hydrogen is introduced into sample.

Steel 8/19/46; Item No. 9450

Electrode Holders

Tweco Products Co., Wichita 7, Kan., is manufacturing a conventional tong type electrode holder which features an almost indestructible molded-laminated glass cloth Bakelite insulation keyed to the holder casting. Ventilated fiber handle is held in place by an internal pressure screw.

Called the Twecotong, it has a fully insulated spring which is protected from splatter by a Neoprene tube. Cable connection permits soldering and clamping of cable to holder. Tongs are made of copper alloy for maximum conductivity and arc burn and splatter resistance. Holder is offered with amperage capacities of 300 and 500.

The company is also manufacturing a semi-insulated Twecotong of the same capacities and similar construction. Only the tong tips, including a portion of

SIMPLEX

One of the best methods of combining high production and precision involves the use of double-end machines with indexing fixtures. Frequently a piece can be completed from the rough in the overall time required by the longest operation. Every production job warrants an analysis of the cost advantages of this method.

A tubular sleeve involving boring, facing and chamfering on both ends is machined in this SIMPLEX 2U 2-way Precision Boring Machine with four spindles and indexing fixture. The work is located and clamped while the boring operation is being performed. The first pair of spindles rough and chamfer the bore on both ends; the second pair precision bore for exact size and finish. The operator's effort is limited to loading the piece, indexing the fixture and pushing a button. This method is subject to many modifications adapting it to a great variety of pieces requiring a combination of operations on one or both ends.

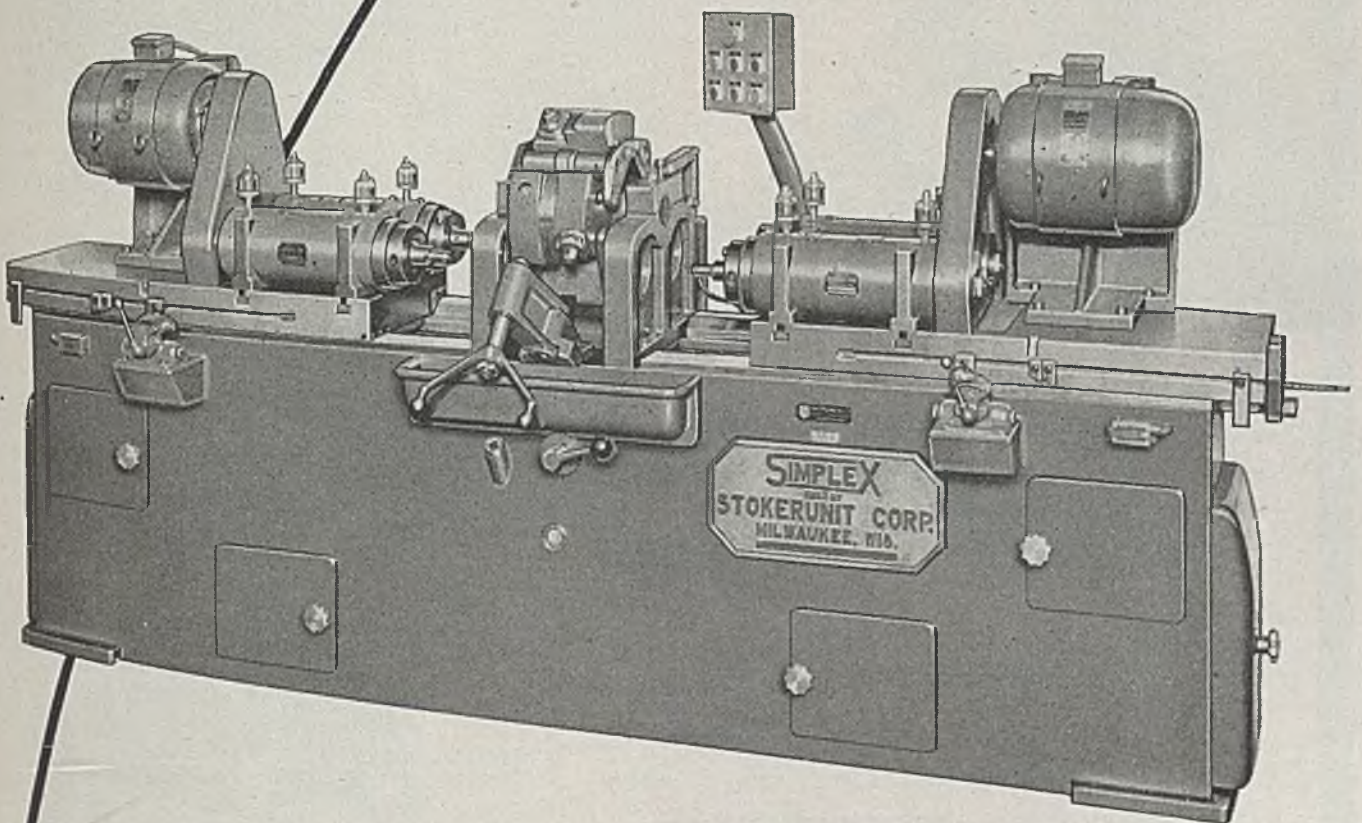

Precision Boring Machines

STOKERUNIT CORPORATION

SIMPLEX Precision Boring and Planer Type Milling Machines

4532 West Mitchell Street, Milwaukee 14, Wisconsin

upper lever and lower body are not provided with insulation.

Steel 8/19/46; Item No. 9483

Master Switch

Type CM master switch for use with mill and crane magnetic controllers is being manufactured by Electric Controller & Mfg. Co., 2700 East 79th street, Cleveland 4. Cam type switch has silver alloy contacts normally spring-closed and opened by 7 in. diameter

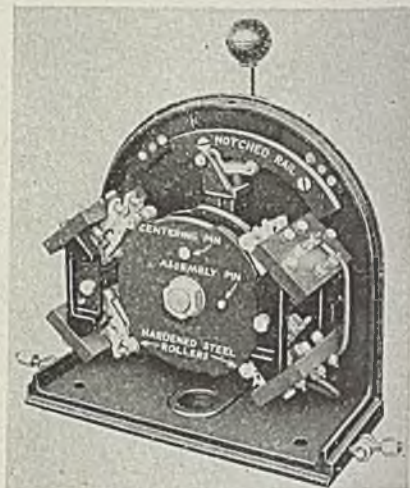

cams. Short throw resulting from use of large cams reduces space necessary for mounting.

Cams are mounted on shaft and keyed in position by centering-pin screwed into keyed roller arm bracket. Assembly pin identifies arrangement of cams for right or left hand operation.

Steel 8/19/46; Item No. 9583

Circuit Tester

Precision Apparatus Company Inc., 92-27 Horace Harding boulevard, Elmhurst, N. Y., is producing a portable, multi-range alternating or direct-current industrial

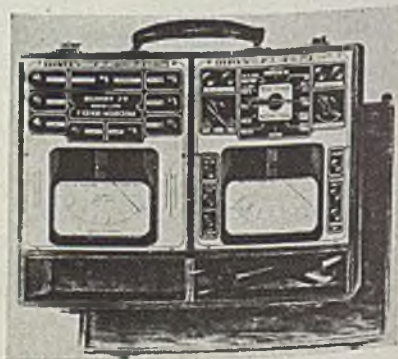

circuit tester, Series 856-J, designed for use in industrial, electric power, laboratory testing and analysis.

Instrument makes possible simultaneous measurements of alternating current

PAGE for WIRE

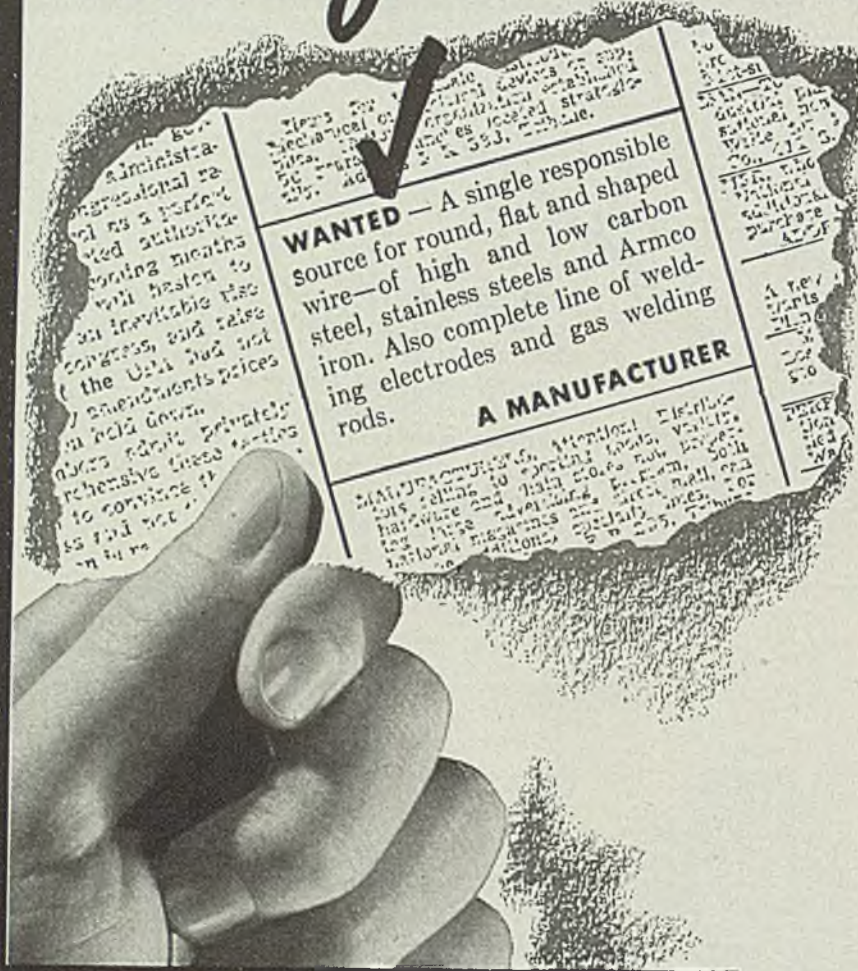

WANTED — A single responsible source for round, flat and shaped wire—of high and low carbon steel, stainless steels and Armco iron. Also complete line of welding electrodes and gas welding rods.

A MANUFACTURER

MANUFACTURERS, Attention: Electric
Wires calling to attention to their
hardware and their products now
for these advantages: 1. Form. 2. Size
3. Material. 4. Quality. 5. Price. 6. Service.

Here's a Want Ad

✓ PAGE Can Answer

Yes, and Page can go a step further than that. PAGE can give you the benefit of long experience in recommending the most efficient use of wire in production. Just remember three words: "PAGE for Wire."

ACCO

Monessen, Pa., Atlanta, Chicago, Denver, Detroit, Los Angeles, New York, Philadelphia, Pittsburgh, Portland, San Francisco, Bridgeport, Conn.

**PAGE STEEL AND WIRE DIVISION
AMERICAN CHAIN & CABLE**





TRUCKS KEEP WORKING STEADILY, ALL DAY LONG, WHEN OPERATED WITH EXIDE-IRONCLAD POWER

You can count on full shift availability—day after day—when the battery power is supplied by Exide-Ironclads. They have the *high power ability* that frequent "stop and go" service demands... the *high maintained voltage* that heavy handling requires... and the *high capacity* that eliminates end-of-day slow-downs.

For greater efficiency and economy... for increased tonnage and lower costs... delegate your materials handling to trustworthy electric industrial trucks and Exide-Ironclad power. It's the combination that assures dependable performance, long-life, minimum maintenance and maximum safety.

Write us for a FREE copy of Exide-Ironclad TOPICS which contains "Case Studies" of materials handling problems. Tells how to cut handling costs up to 50%... covers latest developments in handling materials from receiving to shipping.

DEPENDABLE
POWER



THE ELECTRIC STORAGE BATTERY COMPANY
Philadelphia 32
Exide Batteries of Canada, Limited, Toronto

Dependable Controllers for All Types and Sizes of Lifting Magnets

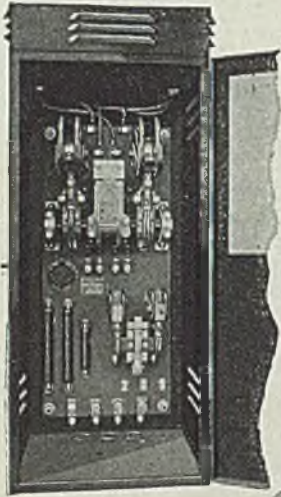

No. 1 Adjustable-Type Controller.



Two-Position Master Switch.

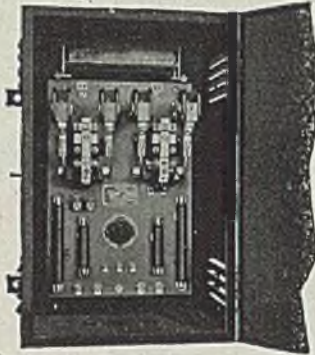

No. 0 Adjustable-Type Controller.



These Magnet Controllers are supplied for use with all types and all makes of lifting magnets. They are designed to speed up lifting magnet operation by a quick, clean release of the load and to perform with minimum upkeep. All No. 1 Controller sizes use the EC&M LINE-ARC Magnetic Contactor for handling power to the magnet—a contactor without equal for interrupting highly inductive circuits in which contacts remain cool and have long life . . . and destructive burning of the arc shields is eliminated.

EC&M Controllers are widely used wherever Lifting Magnets are required.

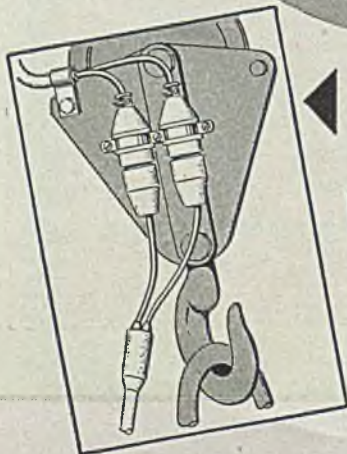

Caution—For longer cable life, fasten magnet leads to crane hook-block.

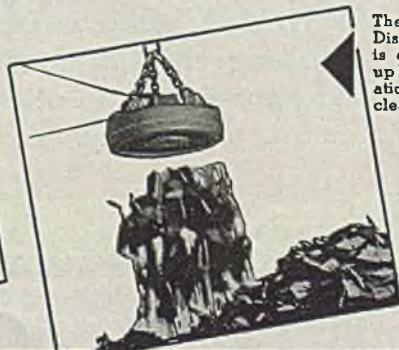

The EC&M Automatic-Discharge Controller is designed to speed up lifting magnet operations through a fast, clean release of the load.

THE ELECTRIC CONTROLLER & MFG. CO.
2698 EAST 79th STREET • CLEVELAND 4, OHIO

—INDUSTRIAL EQUIPMENT—

and voltage with independent readings on the separate meter dials. Accuracy is 3 per cent on either alternating or direct current and 5 per cent on alternating current voltage.

Steel 8/19/46; Item No. 9489

Tension Indicator

W. C. Dillon & Co. Inc., 5410 West Harrison street, Chicago 44, is producing an electric Ters-O-Trol—remote tension and weight indicator which utilizes balanced, self-synchronous motors. The master indicating motor is connected to a dynamometer beam in such a manner that the slightest amount of tension or weight unbalances its field and resulting

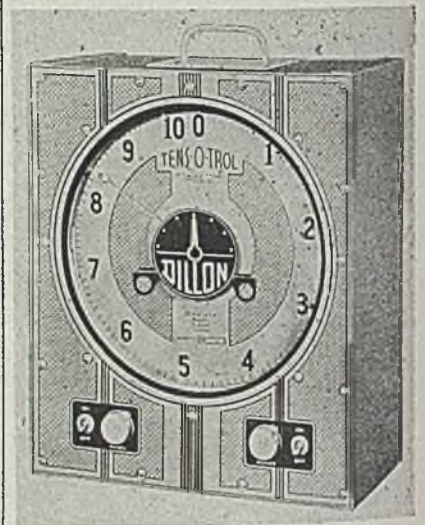

electrical excitation is transmitted by cable to repeater stations where field of receiving motor is correspondingly unbalanced.

A deflection of 0.040-in. is sufficient to render a full scale 360 degree reading. Instrument may be up to 500 ft from dynamometer and will operate on 12 v dc. Nine models with capacities of 500 to 20,000 lb are manufactured.

Steel 8/19/46; Item No. 9490

Die Table Truck

Combination die table and shop lifter now manufactured by Service Caster & Truck Division, Domestic Industries Inc., Chicago, offers advantages of a bench, truck and lifter in a single unit. It is designed to handle loads up to 2000 lb.

Named the Liftable, unit was designed to handle dies in and out of a press but is adaptable for many other purposes. Total lift is 14 in. and height of table top lowered is 28 in.—in raised position, 42 in. Table top measures 26 x 43 in.

Construction is all-steel, electric-welded. Lifting mechanism is a steel screw operating through bronze nut and actuating lift chains.

Steel 8/19/46; Item No. 9476

RESTORE THOSE RUSTED DOLLARS!

New NOX-RUST Non-Corrosive RUST REMOVER

HELPS SALVAGE
THOUSANDS IN
RUSTED PARTS AND
EQUIPMENT!

REPORTS ARE
COMING IN from
all over the country
... of factories closed for
weeks ... production held
up by shortages ... of
parts piled up ... assem-
blies half finished ...
equipment idle ... of rust
slowly spreading ... eat-
ing into inventories ...
piling up costs ... threat-
ening staggering spoilage
losses.

And other reports ... from com-
panies using Nox-Rust's Non-Cor-
rosive Rust Remover ... of rust film
removed by simple dipping ...
heavy scale by light rubbing ... of
parent metal unharmed even by
long immersion ... tolerances held
... critical dimensions unchanged
... machined surfaces restored ...
thousands of dollars worth of rust-
ed material reclaimed.

So ... if your company has not had the foresight
to protect exposed metal surfaces with a Nox-
Rust protective coating ... we suggest this recipe
for hindsight: Try our new Rust Remover ... that
acts more rapidly than most ... lasts longer ...
yet is up to 80 times less corrosive to sound metal,
by quantitative tests, than other widely used prod-
ucts. Immediate Delivery. For prices, consult our
nearest branch office (Newark, Buffalo, Cleveland,
Detroit, San Francisco, Los Angeles) or write to
us direct, today.

SAVES
MONEY

Chemicals for American Industry
NOX-RUST
CHEMICAL CORPORATION

SAVES
METAL



Mathews offers you

COMPLETE

**CONVEYER
SERVICE**



PROBABLY one of the most distinct advantages that Mathews makes available to industry today is a conveying service that is complete. Proposal engineering, estimating, detail engineering, fabrication, and erection in the field, all are part of this thoroughly organized effort. A competent field engineering staff, an experienced engineering force at the plants, modern factories and highly skilled personnel make this complete service possible. Plant engineers have learned that this complete service can make the material handling phase of their job easier, and help them to do it better.

When you need conveying equipment, remember that Mathews complete service can be yours for the asking, without obligation. Whether your problem requires gravity or power conveyers, or special conveying machinery, you will find Mathews Engineers in a position to help you make the most practical application.

MATHEWS CONVEYER COMPANY
ELLWOOD CITY, PENNSYLVANIA
SAN FRANCISCO, CAL. • PORT HOPE, ONT.
ENGINEERING OFFICES IN PRINCIPAL CITIES

Improvement Program

(Continued from Page 134)

increased length of skelp required for the double length butt-weld mills. Setting up the new facilities, of course, involved a rearrangement of the finishing equipment and the installation of threading and testing equipment, which in turn made it necessary to rearrange the finishing end of the galvanizing plant.

Two conveyors are being installed at Nos. 3 and 7 butt-weld mills to handle pipe from the hot finishing end. These conveyors will be located underground and will free overhead cranes for other service.

The hot end of the galvanizing department has been rearranged and a large continuous galvanizing machine installed. Modern ventilating heat facilities also have been provided. When the work is completed in this department all galvanized pipe manufactured by National Tube will be coated at Lorain Works.

New Warehouse Included

Adjoining the finishing end of the butt-weld pipe mills is a new warehouse, 1326 x 125 ft, which will rank as one of the most modern storage buildings in the country. Stocking area will be sufficient for 40,000 tons of finished material. At the present time the structural steel work is well under way. An even temperature will be maintained throughout the building by hot water coils installed in the cement floor to provide radiant heating. The building will have no windows. Daylight-type artificial lighting will be used. Change of air will be provided through ventilators installed in the roof and louvers in the sidewalls. Provision has been made for offices and sanitary equipment for shipping crews. Storage racks will be built up to a maximum height of 20 ft to suit different sizes of pipes. Four overhead cranes will service the floor. The building will be divided into four shipping areas, each shipping unit handling its own station sizes. Standard railroad cars will move lengthwise through the warehouse, and progressing through the various areas will pick up the different classifications of pipe to complete mixed carload lots.

Light blue paint will be used above all roof trusses; cranes and other prime movers will be painted a bright orange color and all columns a light gray to match the walls. In order to afford high visibility the top 18 in. of the pipe racks will be painted a bright orange.

The warehouse not only affords better working conditions for the employee but protection against the elements as well for storage of pipe under 4½-in. outside diameter. Building this warehouse in its present location involves the removal

Exceptional HEAT UNIFORMITY



...with **MAEHLER** ovens...

... mean more uniformly baked cores

RECENT TESTS SHOW ... temperature variations of only 5°

93.6%
OF MAEHLER'S PRODUCTION
IS DEVOTED TO REPEAT ORDERS!
..... There is no better proof of
the superiority of Maehler ovens
and furnaces.

MAEHLER'S leadership in developing the recirculating air heat system for industrial ovens has resulted in a line of equipment that gives heat uniformity that is virtually perfect! Recent tests show that a Maehler oven operating at 500°F fully loaded maintained a heat uniformity within 5°, through high volume and rapid air heat circulation and highest grade instruments. This kind of temperature control means uniform baking ... no under-baked nor over-baked cores.

Maehler core and mold ovens are available in a complete range of oil fired, gas fired and electrically heated units, incorporating the Maehler recirculating principle for high uniformity and output, at low cost.

Let us quote you on your requirements.

THE PAUL MAEHLER COMPANY
2233 W. Lake Street • Chicago 22, Ill.

A Few Users of
MAEHLER EQUIPMENT
AMERICAN BRAKESHOE
& FOUNDRY
GREENLEE BROS.
PACKARD MOTOR CAR CO.
EBALLOY FOUNDRIES
BOHN ALUMINUM
& BRASS CORP.
GENERAL MOTORS CORP.
SARGENT & GREENLEAF
HOWARD FOUNDRIES

MAEHLER

Industrial Ovens and Furnaces
for Core Baking, Mold Drying,
Heat Treating, Enameling, etc.

Vertical Storage with BAKER TRUCKS

more than doubled Storage Facilities



Case History of
MERCK & CO., INC.
Manufacturing Chemists
Rahway, N. J.

Hy-Lift Truck illustrated has oversize "safety" platform providing greater carrying space. Operator can raise or lower load by remote control from the platform.

(Inset, above) Baker Low-Lift Truck moves capacity load easily up a 10% ramp 70 feet long.

(Below) This 4000 lb. Baker Truck does double duty. Besides its own big load, it hauls a loaded trailer.

In 1926, Merck & Co., Inc. bought its first Baker electric truck. Twelve years ago they found that storage along horizontal lines provided inadequate warehousing space to meet increasing needs. Rather than build an addition, they decided to install a Baker Hy-Lift Truck to tier material, thus using available vertical storage space. So successful

was this truck—not only in providing more storage capacity but also in speeding material movement—that more and more were installed, until today the Company operates a fleet of 18 Baker Trucks: Eleven Hy-Lift Trucks, two Low-Lift Trucks, two Fork Trucks, and three Platform Trucks. Besides obviating the need for new building by increasing existing storage facilities, these trucks are conserving time and manpower on handling operations throughout the plant.

A Baker Material Handling Engineer can help you make similar savings. Write for information.

BAKER INDUSTRIAL TRUCK DIVISION of the Baker-Raulang Company
2167 West 25th Street • Cleveland 13, Ohio
In Canada: Railway & Power Engineering Corporation, Ltd.

Baker INDUSTRIAL TRUCKS

of some 14 tracks leading into an adjoining building, and not only replacing these in a new location, but changing their direction as well.

The improvement program in general involves the laying of five miles of new railroad tracks of standard and narrow gage. This is a major operation inasmuch as the new trackage will run east and west and parallel the warehouse instead of north and south as it does now.

New Filter Designed for Cleaning Light Oils

Primarily designed to filter light hydraulic oils used in operation of hydraulically operated machine tools, an economical and easily installed filter using the Skinner ribbon pack has been produced by Skinner Purifiers Inc., Detroit.

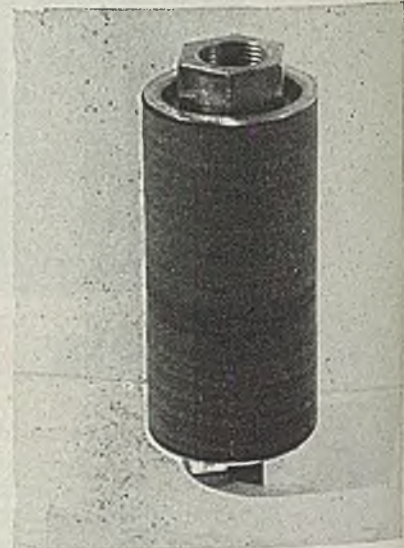

Also it can be used for air filtration in pneumatic tools.

The unit has a capacity of 5 gpm. Dirt particles 40 microns and larger in size are removed from the fluid. Filter is 3 in. in diameter and 6 in. in length, but can be made longer for greater flow rates. For convenience in installing in the tank and in removal for cleaning, the unit is equipped with a 1-in. hex nut on one end, as illustrated.

Experience of some users is said to have shown that the dirt removal obtainable has decreased maintenance cost on the equipment.

Papers on Stress Analysis

Experimental Stress Analysis, Vol. III, No. 2; cloth, 172 pages 8½ x 11 inches; published by Addison-Wesley Press Inc., Kendall Square, Cambridge 42, Mass., for \$5.

This volume contains papers presented before the Society for Experimental Stress Analysis. The papers are highly technical and deal with various phases of the use of strain gages and other applications to testing methods on a number of industrial materials.

Here's why they switched . . .

grey iron: 21 lbs.

magnesium: 5.1 lbs.

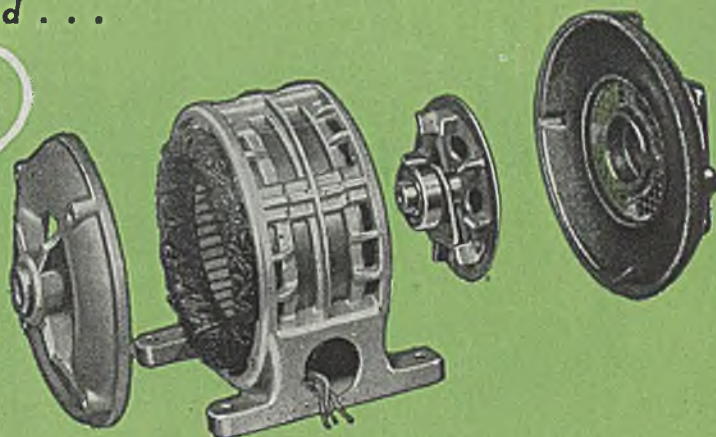

A switch in materials brought about this 75% cut in weight! It was a job magnesium took in stride—lightening a 5 h.p. electric motor for aircraft use.

One group of parts—motor housing, bearing brackets, fans—weighed 21 pounds in cast grey iron. Magnesium sand castings brought that weight down to 5.1 pounds . . . a saving of 15.9 pounds! Rigid tests and extensive use proved the application a complete success—another of magnesium's many product-improving achievements.

Progressive designers and manufacturers have made great strides in magnesium application, and many industries are following suit with equal success. Dow engineers, available through the nearest Dow office, offer valuable technical aid in the use of this lightest structural metal.

*Ready...
to make products move!*

MAGNESIUM

LIGHTEST OF ALL STRUCTURAL METALS



This tapping operation on a radial aircraft engine is one of the standard procedures for machining magnesium.



Modern magnesium applications include many such units as this oil tank, its parts being joined by gas welding.



Uniformity is maintained by close attention to such details as the inspection of these Dow magnesium sand castings.

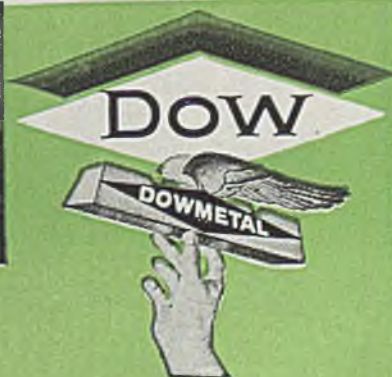

MAGNESIUM DIVISION • THE DOW CHEMICAL COMPANY, MIDLAND, MICHIGAN

New York • Boston • Philadelphia • Washington • Cleveland • Detroit • Chicago • St. Louis • Houston • San Francisco • Los Angeles • Seattle

ATLAS INTRAPLANT HAULAGE EQUIPMENT

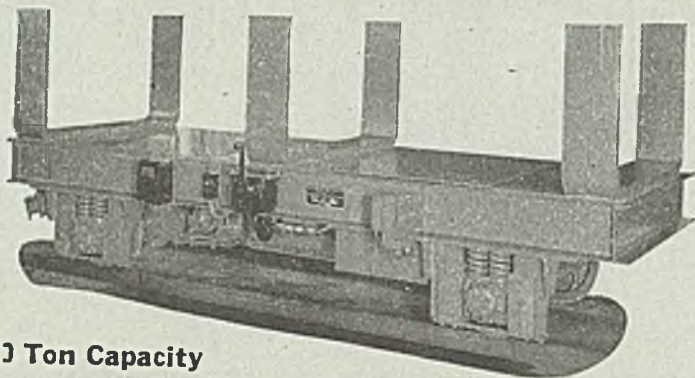

23 Ton Capacity

STORAGE BATTERY FLAT CAR

For handling long bars. Powered by storage battery. Geared to travel at walking speed when controller is held in operating position. Spring return to "off" when released, at which point magnetic brake is set.

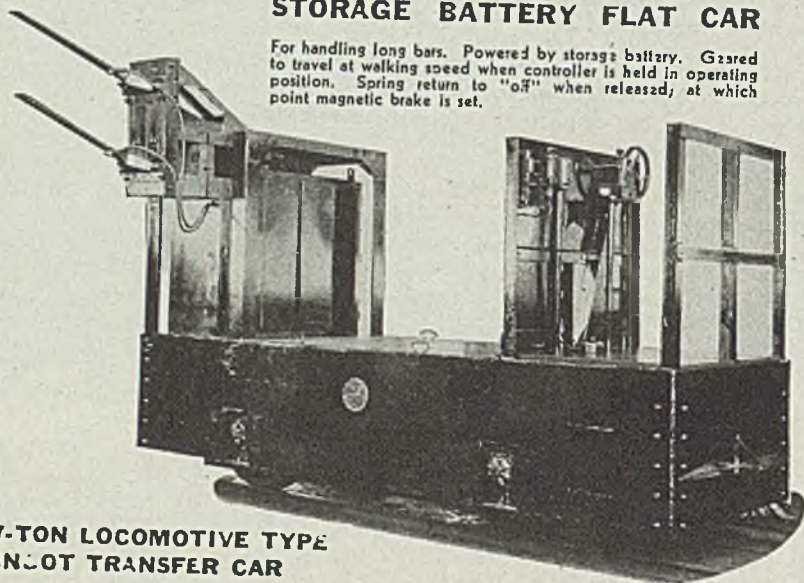

7-TON LOCOMOTIVE TYPE INCOT TRANSFER CAR

Operator station in elevated position at one end of car with magnetic switch control located opposite end. Car is provided with hydraulic brake system with anti-friction roller bearing—spring mounted journals.

BUILDERS OF:

DIESEL ELECTRIC AND STORAGE BATTERY
LOCOMOTIVES FOR INTRAPLANT HAULAGE
SCALE CHARGING CARS AND ORE TRANSFERS
FOR BLAST FURNACE STEEL PLANTS

COAL CHARGING CARS, CLAY CARRIERS
DOOR EXTRACTORS, COKE GUIDES AND
COKE QUENCHING CARS FOR
BY PRODUCT COKE PLANTS

TURNTABLES

INDICATING AND RECORDING DIALS
FOR WEIGHING SCALES

The ATLAS CAR & MFG. CO.

ENGINEERS

MANUFACTURERS

1100 IVANHOE RD. CLEVELAND 10, OHIO, U. S. A.

Brazing Tool Tips

(Concluded from Page 101)

20 tools ranging in size from ¼ to ¾-in. square, and of moderate length.

Because the mechanism of the fixture is attached to a stationary bracket, an adaptor plate is used when changing to another size. Tools are held in the fixture by spring tension and, as the operator manually rotates the block, the tool enters the field of the inductor coil where it becomes heated. The tip is "wiped" in place by the operator during the heating after which the tool passes down and out of the inductor as the very short cycle concludes. Held by mechanical tension until it arrives at the vertical, the tool is released from the fixture automatically and drops into a tote box or onto a conveyor below.

Because the flux is sufficiently adhesive, it is not necessary to hold the tip in position by any other means as the tools pass into and out of the inductor.

At Willey's, the induction method also is making it possible to silver solder high speed steel tips without drawing the hardness of the tip. In addition, it simplifies the removal of a brazed tip from a shank by quickly remelting the brazing material.

Larger tools, 1¼ x 1½-in. for example, are now treated in greatly increased quantities. Two girl operators are capable of turning out 85 of these an hour on a 2-station unit. In handling the large tools, a single magnetic chuck block 6 in. long is used to hold the big shanks.

The process also makes it possible to braze a 2-tipped tool without the wiring usually required to secure tip. Tips are held in place during the heating without extra support. The same procedure is followed in treating drills, reamers and counterbores.

Brazing of diamond dressing tools, with single diamonds was always difficult to handle and slow to braze. Now, after the stone is positioned and the matrix base is pressed into the tool cavity around the diamond, one girl can braze 150 to 200 half-inch tools per hour. The cycle is 3 sec heating per dresser.

Carbide Threading Tools

A new line of standard carbide tipped threading tools, said to be particularly suitable for long run threading of steel parts, is now available from Carboloy Co. Inc., Detroit. Tools are of 60 deg V-nose type, designated as style T-15 and are made of Carboloy grade 78-B.

Shank sizes offered are ¾, ½, ⅜ and ¼-in square styles. Shank lengths run from 2½ to 4½-in. Primary clearance at nose of tool is 3 deg and secondary clearance is 6 deg.

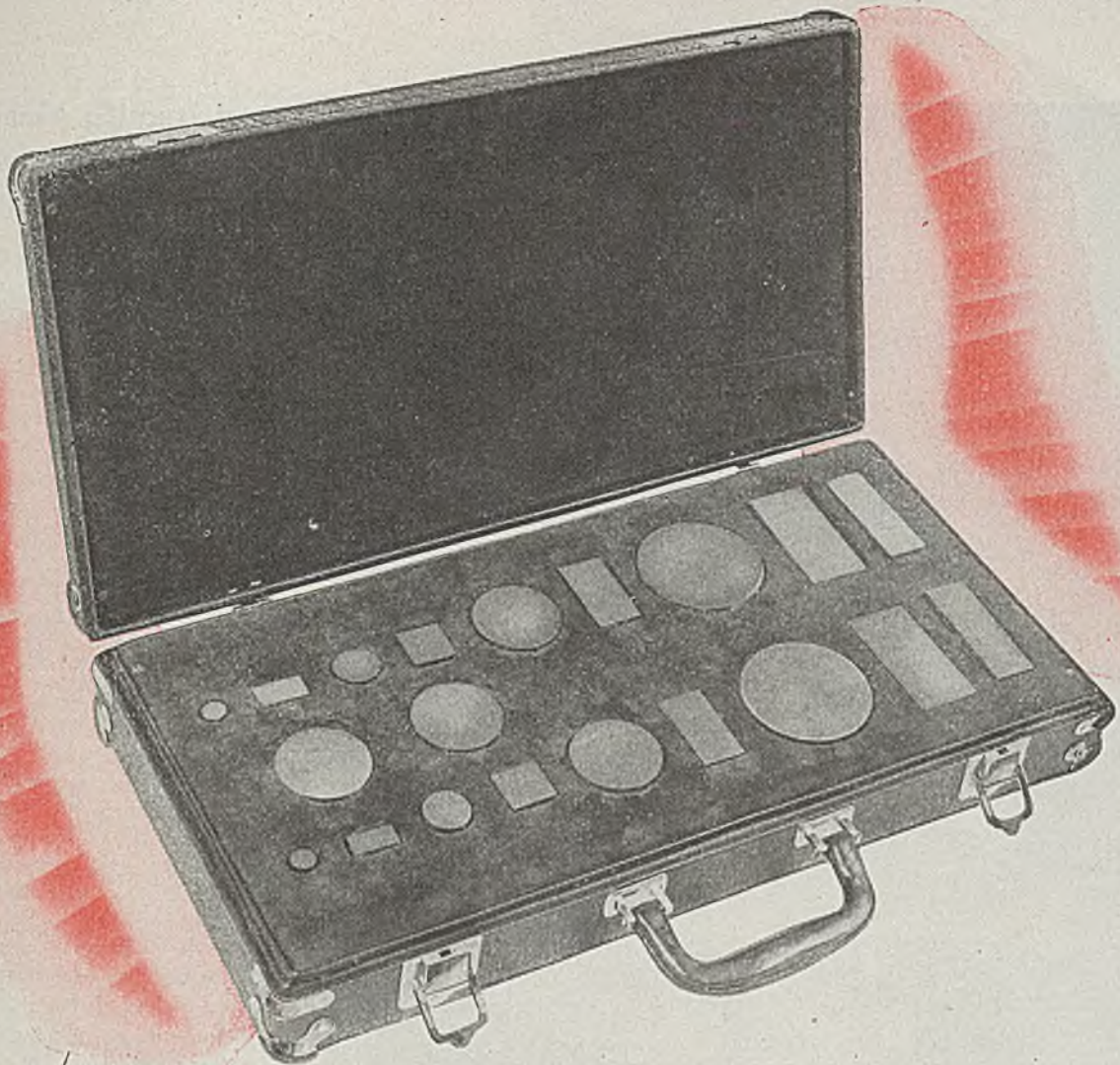

NO ORDINARY LUGGAGE

...this demonstration kit!

It's not just an ordinary traveling case . . . it doesn't contain ordinary samples! It's the demonstration-kit used by our sales engineers, to show you at a glance the difference between ordinary high speed steels and high speed steels made by Latrobe's new *DESEGATIZED* process.

This new method, exclusive with Latrobe, makes high speed steel free from carbide segregation. *Desegating* is the most revolutionary development in the perfection of high speed steels in 25 years and sets new standards of quality for the tool steel industry!

A Latrobe technical man will gladly bring you the portable kit which shows the advantages of Desegated High Speed Steels. Write our nearest office.

Write also for our new booklet describing Latrobe's improved Desegated Process.

LATROBE
DESEGATIZED
 HIGH SPEED STEELS

LATROBE ELECTRIC STEEL COMPANY • LATROBE, PENNSYLVANIA

BOSTON • HARTFORD • NEW YORK • PHILADELPHIA • WASHINGTON • PITTSBURGH • BUFFALO • ROCHESTER • CLEVELAND
 TOLEDO • DAYTON • DETROIT • CHICAGO • MILWAUKEE • SEATTLE • LOS ANGELES

August 19, 1946

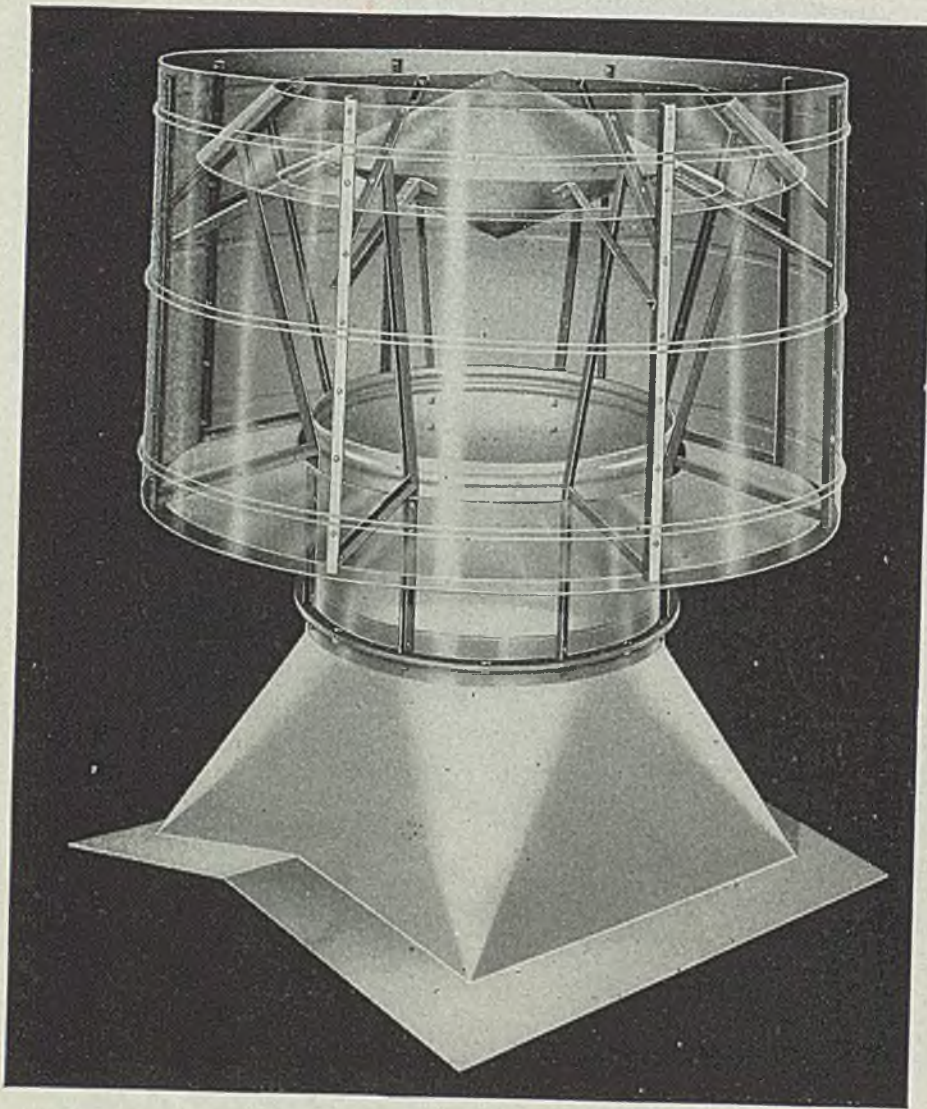

This BURT Free-Flow Gravity Ventilator Gives Your Plant Tremendous Air-Moving Ability In the Simplest Possible Form

Tradition has been disregarded in redesigning and improving the Burt Free-Flow Gravity Ventilator. In this modern design the entire discharge from the ventilator is vertically upward for greater efficiency and to eliminate condensation of moisture onto the roof below the ventilator. There are no internal louvers to impede the free flow of air—no moving parts to service. Its construction is simple and strong for long life and easy erection. Where a super-capacity stationary ventilator is indicated, the Burt Free-Flow is your best specification. In Burt's complete line of gravity, fan and continuous ridge ventilators you will find a type and size for any requirement. See Sweets' or write for data sheets—now.

WRITE FOR CATALOGS AND DATA SHEETS

The **BURT MFG. Co.**

ROOF VENTILATORS

OIL FILTERS

EXHAUST HEADS

505 So. High St., Akron 11, Ohio

Heat Treating Aluminum

(Continued from Page 99)

greatly and the metal is said to "work harden".

Thus as the shape of the metal piece is changed by working it mechanically, more and more slip planes are used up and the metal becomes progressively harder and less capable of further working. It is evident that metals possessing few slip planes quickly reach a point where excessive force is required for further working or where the metal structure may even break down if all available slip planes have been "used up".

Annealing: However, the original workability of the metal can be restored by producing a "fresh" set of crystals having an entirely new set of slip planes. This is done by heating the previously worked metal to a point where a new crystal structure is produced. This temperature is called the "recrystallization" point or "temperature of recrystallization". Aluminum alloys require comparatively low temperatures, in the neighborhood of 300-750° F. This operation is easy to control and reliable results can be had with little difficulty on most of the aluminum alloys. (Recommended specific treating cycles will be given in Part III.)

Suppose we are forming a deep drawn aluminum cup from a flat circle. Instead of attempting to produce the cup from the flat in a single forming operation, the final shape may be attained in steps or stages, annealing the part between successive operations wherever necessary to correct work hardening. In this manner it is possible to keep each step within the practical working limits of the material and not draw the sheet past the point where excessive work hardening would cause cracks or breaks. This is why many articles formed from aluminum alloy sheet involve a sequence of press operations with a series of intermediate annealing treatments.

It is important to understand the influence of time in heat treating metals. For instance if in the above described annealing process, the work is not held above the recrystallization temperature long enough, the new crystals will not have a chance to form completely. It takes a certain amount of time to form the new crystal structure. In fact, most changes in the structure of the metal require a certain amount of time for completion.

Also time is required for the heat to soak throughout all portions of the metal piece being treated. This is necessary in order that sufficient temperature rise be produced in all sections to provide the change in metallurgical structure that we desire. While a fast treatment in a

Facts and Figures on New and Expanded Facilities of
the Steel Industry are now revealed in

STEEL EXPANSION FOR WAR

By W. A. HAUCK

An official report by Mr. Hauck
for the War Production Board

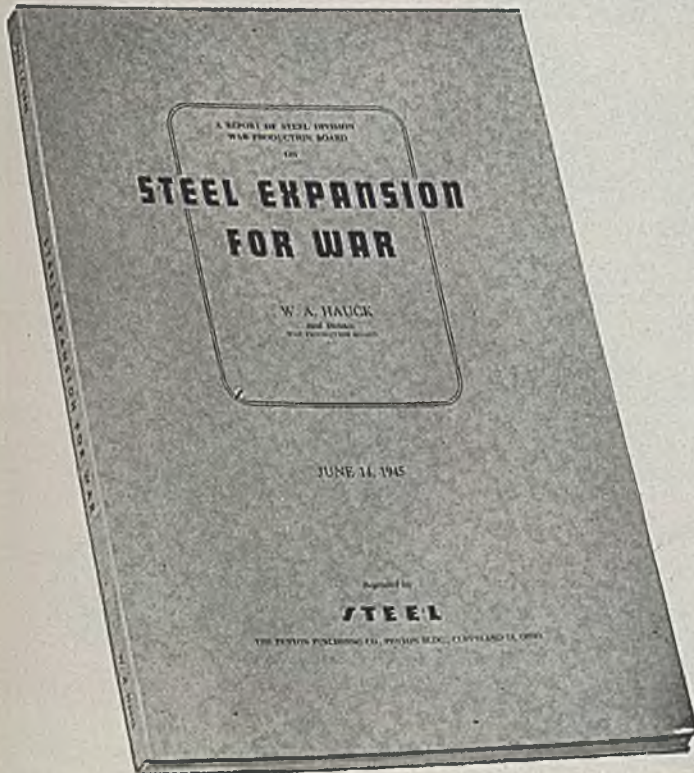

THIS 192-page handbook is an official report prepared for the War Production, the Reconstruction Finance Corporation and other government agencies.

Much heretofore unpublished information is presented on new and revamped facilities of hundreds of plants, including

those in the ore, ore transportation, coal and coke, refractory, ferro alloy, scrap, foundry and forging industries.

The report provides details on types of products, capacity increases, plant locations, costs, etc. Included are 148 photographs, plus charts and tables.

NEW SUPPLEMENT—An 18-page supplement prepared by Mr. Hauck for the Reconstruction Finance Corporation and included at no extra charge—brings the report completely up-to-date. It will serve as a valuable reference for many years.



STEEL—Book Department
Penton Building, Cleveland 13, Ohio

Please send copies of STEEL EXPANSION FOR WAR, by W. A. Hauck, postpaid. (Discount on 10 copies and over.)

- Payment is enclosed.
 Send invoice to company as shown below.

Name..... Title.....

Company.....

Address.....

City..... Zone..... State.....

*Please add 3% state sales tax on orders for delivery in Ohio

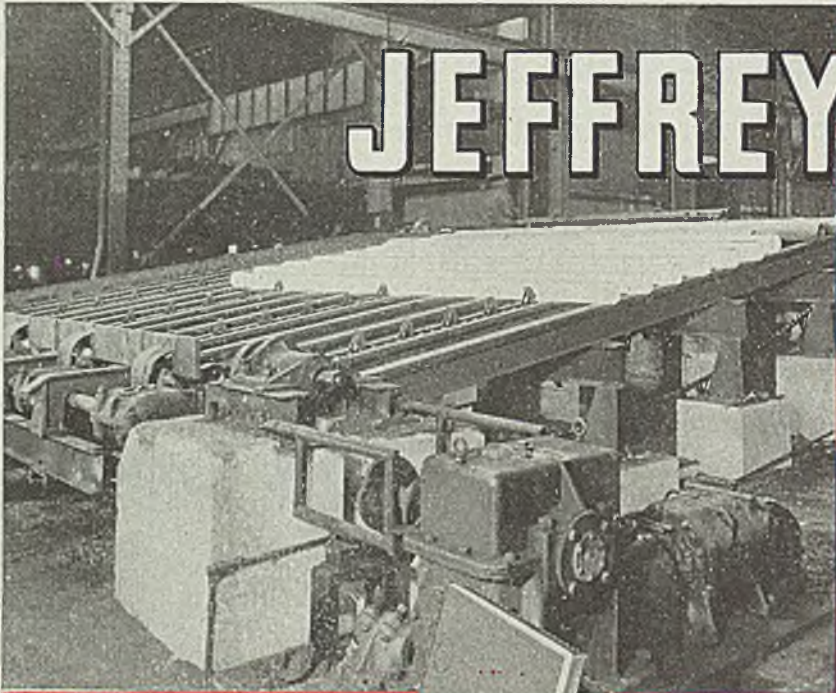

JEFFREY CHAINS

IN THE
STEEL MILL

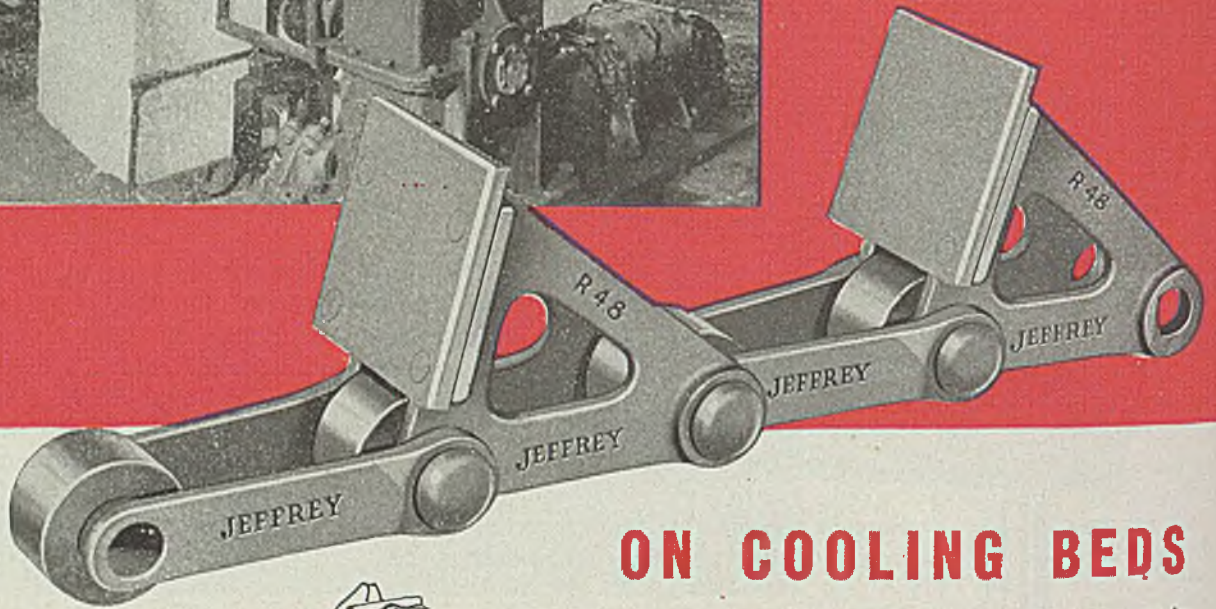

ON COOLING BEDS



Have you ever watched a fellow "roll his own" in one hand . . . with straight fingering and equalized bearing from end to end? He rolls a good cigarette. But if his fingers slip, something goes wrong. Balance is the trick.

It's exactly like that on a cooling bed in the steel mill. Comparable accuracy of "touch" is required of attachments to the conveying chains. Unless the pushers remain in constant alignment, pipes and tubes will not come off commercially straight. Jeffrey cooling bed chains are trued up to this exacting service . . . malleable roller chain for general service . . . steel thimble roller chain for more demanding, heavy-duty service.

THE JEFFREY

MANUFACTURING COMPANY

533-37 North Fourth St., Columbus 16, Ohio

Baltimore 1	Buffalo 2	Cleveland 13	Haris	Milwaukee 11	Pittsburgh 22
Birmingham 3	Chicago 1	Denver 2	Houston 3	New York 7	St. Louis 2
Boston 14	Cincinnati 3	Detroit 11	Hartington 19	Philadelphia 3	Salt Lake City 1
					Scranton 2

ESTABLISHED
1877



STEEL

furnace operated at a higher temperature might bring the interior of the work up to temperature quicker, it would be almost sure to heat the edges and corners of the work to excessive temperatures and probably damage those portions.

For these reasons, allowance for proper time "at temperature" is essential in any heat treatment.

The time element enters into heat treatment in another important manner. Because a certain period of time is required for the structural or metallurgical changes to reach a completed or stable stage, it is possible to change quickly the temperature of the metal and thereby obtain at room temperature certain desired types of structures that could not otherwise be had at room temperature.

But before getting into heat treating cycles and structures of aluminum alloys, let's start out with a pure metal for the sake of simplicity and see how this time element influences the structure.

Fig. 4 indicates the relation between time and temperature as a pure metal is allowed to cool from the molten state, represented by point "A". As its temperature falls, it reaches a point "B" where the metal begins to solidify or freeze. For pure aluminum, this freezing point is 1214.6° F.

Note that the curve indicates the temperature remains at this value for a period of time. This is because the change from a liquid to a solid is accompanied by the release of heat, the mechanism of the operation being such that just enough heat is released to balance that being lost, thus retaining the temperature of the metal constant during the period this solidification is taking place. So the curve is level from "B" to "C".

As soon as the metal has completely solidified, its temperature again falls gradually as it is allowed to cool, represented by the sloping line "D".

It should be noted that only the pure metal follows this type of curve . . . and each different metal has a different solidification or freezing point; i.e., the level portion of the curve or "plateau" will come at a different temperature.

Now let's see what happens when we melt two pure metals together—let's say aluminum and copper—and allow them to cool. We find that we have a curve of an entirely different shape because the combination of the two metals has a freezing "range" instead of a freezing "point"; that is, the material begins to freeze at one temperature and continues to freeze while the temperature falls to a lower value before all of it has solidified. This is shown by the dotted portion of the curve at "F" in Fig. 4 where the curve slopes from "E" to "G".

The combination of aluminum and copper does not freeze or solidify com-

STEEL

FOR SPECIAL JOBS ... LIKE YOURS

For 36 years Ingalls has furnished fabricated steel for power plants, bridges, multi-storied buildings—and for special jobs like yours. Complete fabricating facilities.

More POWER to YOU

Ingalls steel was used in these new power plants. At right, addition to the Georgia Power Company's Plant Atkinson, Harryat, Ga. Below, power house for the Aluminum Company of America, Mobile, Ala.

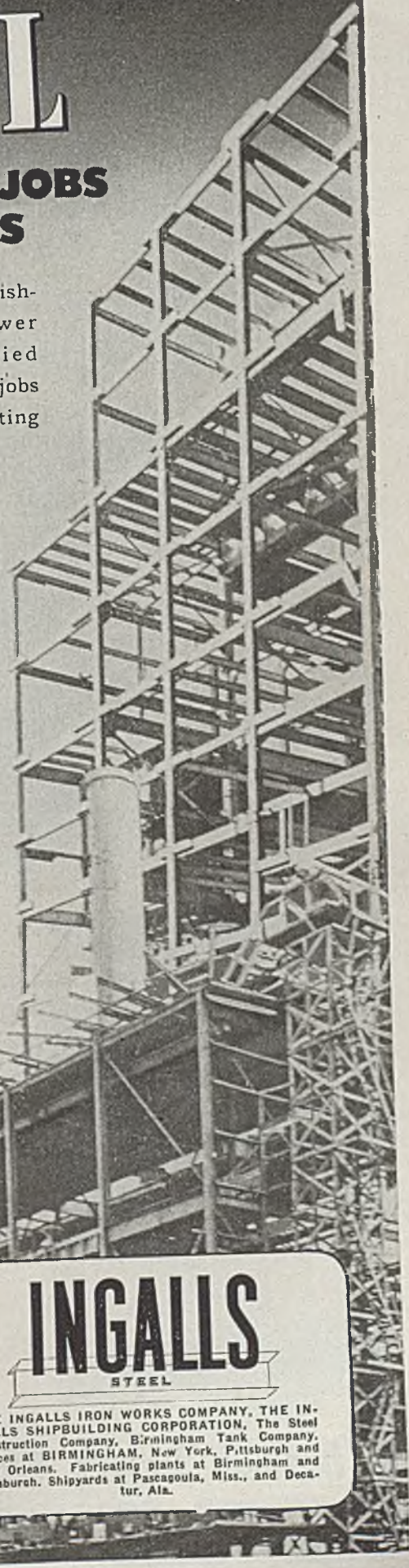

INGALLS

STEEL

THE INGALLS IRON WORKS COMPANY, THE INGALLS SHIPBUILDING CORPORATION, The Steel Construction Company, Birmingham Tank Company, Offices at BIRMINGHAM, New York, Pittsburgh and New Orleans. Fabricating plants at Birmingham and Pittsburgh. Shipyards at Pascagoula, Miss., and Decatur, Ala.

Production Screwdrivers

Speed up

**YOUR SCREWDRIVING ASSEMBLIES
BY USING THESE MACHINES**

Model B
Will Drive
Screws from
No. 6 to
No. 1/4,
in Lengths
3/16 to 1 1/2
Inches

All Screws
Driven to
a Uniform
Tension

No Marring
of Heads

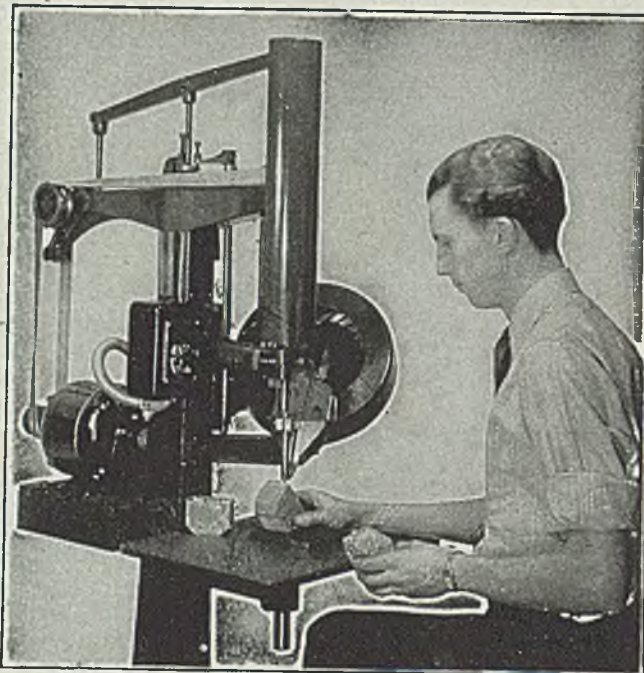

MODEL B

MODEL A

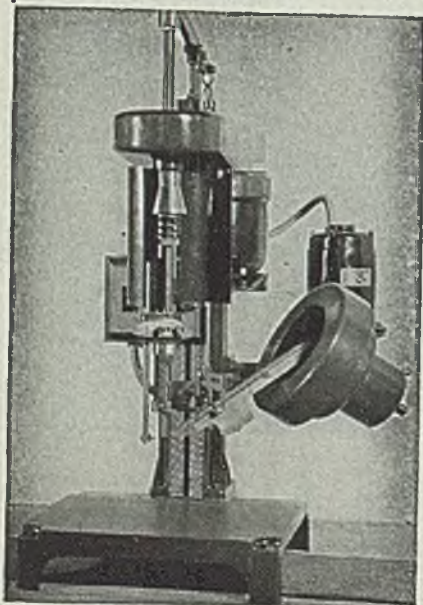

Model A Is Designed
to Handle Small Screws
in Sizes
From No. 2 to No. 6
In Lengths
From 3/16" to 3/4".

Driving Time
One Second Per Screw

Send Sample Assemblies
for Production Estimates
and Quotations
ASK FOR CATALOGUE

Detroit Power Screwdriver Co.

2813 W. Fort St., Detroit 16, Mich.

pletely at a single temperature because the mixture formed by the two metals behaves in an entirely different manner than does a pure metal such as copper, or aluminum. Suppose we examine this freezing action for a moment, tracing the new curve on Fig. 4.

Differential Freezing: At "E", Fig. 4, the crystals forming out as the molten metal is just beginning to solidify will consist of an alloy of almost pure aluminum. As the temperature falls, crystals with appreciable amounts of copper will begin forming. With continued dropping temperature, the crystals forming will contain more and more copper. Thus at "E", the alloy particles freezing out may contain 99.9 per cent aluminum, 0.1 per cent copper. Just below "E", the particles freezing out of solution may contain 99 per cent aluminum, 1 per cent copper. Similarly, particles containing 98 per cent aluminum 2 per cent copper will freeze out at a still lower temperature, etc.

Thus as the temperature falls, the material freezing out of solution at any particular moment corresponds to the alloy of aluminum and copper that freezes at that particular temperature.

This accounts for the fact that as the temperature curve traverses the "F" portion, Fig. 4, the alloy particles or crystals forming out the molten metal contain more and more copper. At "G", the entire mass becomes solidified and the temperature drops along the same type of curve as before.

When the molten metal contains more than two elements, this curve changes considerably and the freezing action becomes increasingly complicated. It is evident, that in an aluminum alloy where we may have six to nine different elements, the action may be extremely complicated, especially because the many different elements in turn form various mixtures or compounds which may behave in still different ways to further complicate the situation.

Precipitation: One of the complications that results from having these many different elements in the aluminum alloy is that certain combinations of elements may form mixtures or compounds which may freeze out of solution or separate out in small independent particles before or even after most of the other material has solidified.

These particles may be extremely small and may exist between the surfaces of adjoining crystals in such a manner as to "lock" the crystals by hindering them from sliding and thus increasing the resistance to mechanically working the material. This in turn may make the metal hard, tough, brittle, etc. Depending upon circumstances, the result may be desirable or undesirable.

This precipitation or separating out

from the molten metal can be demonstrated in this manner: Place several spoonfuls of salt in a glass of boiling water, adding salt until no more will dissolve and some remains in the bottom of the glass even after repeated stirring. Pour this solution into another glass, leaving behind the extra salt. We now have a "saturated" solution of salt in water. Then place this glass in a basin of cold water and stir the solution. As it cools, the temperature will drop to a point where the water can not hold all of the salt in solution. We now have a "supersaturated" solution in which the extra salt will immediately form salt crystals as it "precipitates" out of the solution in the glass.

The same thing happens when a molten aluminum alloy is allowed to cool. Various elements and combinations of elements will precipitate out of the molten alloy as the temperature falls to a point where they can no longer be held in solution. And the alloy does not have to be molten, for certain compounds may precipitate out of the metal after it has solidified.

When a constituent precipitates out, it may accumulate between grains along grain boundaries, or in the form of minute particles between crystals inside the grains. These particles may thus be present in the slip planes between adjacent crystals. If the same particle is partially imbedded in both surfaces of adjoining crystals, it is evident that they will tend to lock those surfaces together and prevent them from sliding freely one on the other. Thus they will tend to increase the resistance to slippage between crystals because of this "keying" effect.

With slippage made more difficult, the metal acts as though it had fewer slip planes, is harder to work and may be considerably stronger. So the end result may be that the mechanical properties of the metal are greatly improved. As we will see, this is the aim of certain heat treating cycles.

Remember, we have not only solids precipitating out of a liquid (the molten metal), but also solids precipitating out of solids, because just as a solid metal can diffuse into another solid metal (described under "homogenizing" page 162), so can a solid precipitate out from another solid. To illustrate this latter action, however, there is no simple analogy like that of the salt and water previously mentioned.

Segregation: When molten aluminum alloys are poured into molds and allowed to cool to form ingots (casting), the surfaces of the ingot that contact the mold naturally cool faster. So the first crystals to be formed are in the ingot surfaces contacting the mold walls. Then as the

THE CHARM OF A

Beautiful Finish

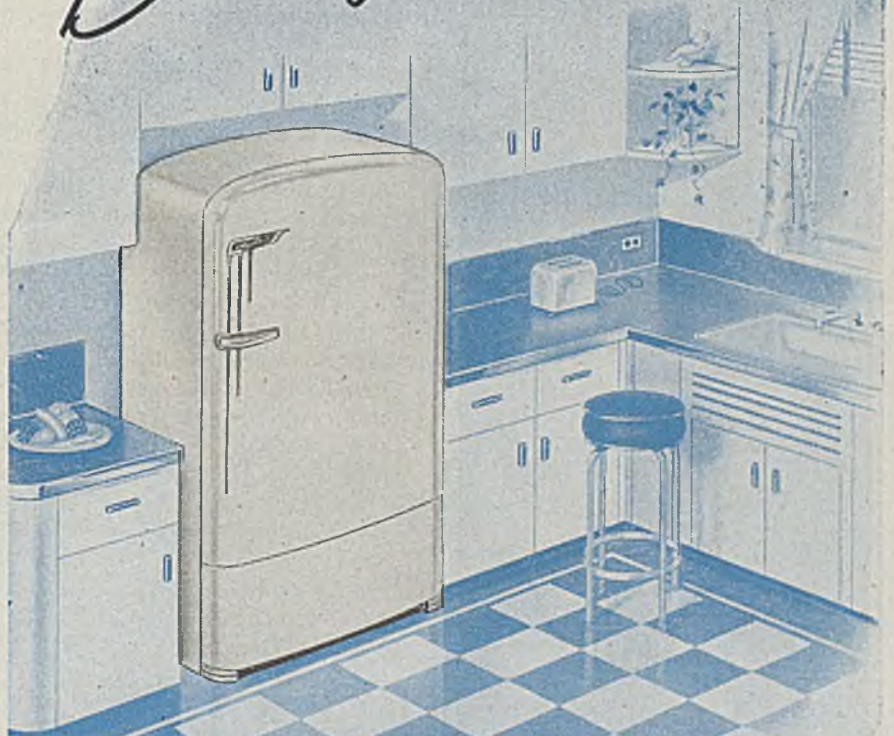

GRANODIZED

Spray Granodizing metal surfaces assures a durable, lustrous paint finish. The smooth, tight, hard, phosphate coating anchors paint to the metal for permanent protection; preventing the spread of rust from accidental injury to the paint finish.

The appealing beauty of the paint finish when applied to a Granodized surface will endure, whether it be the finish of automobile, refrigerator, washing-machine, kitchen cabinet or other products constructed of sheet metal.

PAINT DURABILITY IS *Certified*
WHEN METAL SURFACES ARE
GRANODIZED



MANUFACTURERS OF INHIBITORS AND METAL WORKING CHEMICALS

AMERICAN CHEMICAL PAINT CO.
AMBLER **ACP** PENNA.

Greater Tonnage
Per Edge of Blade

A

**AMERICAN
SHEAR KNIFE CO.**
HOMESTEAD · PENNSYLVANIA

temperature of the metal continues to fall and more crystals are formed, the new ones form on top of the older ones, causing the metal grains to "grow" toward the center of the ingot in a direction at right angles to the mold walls.

At the same time the rapid extraction of heat through the mold walls is causing the grains to grow inwardly from the ingot surface, the temperature difference produced between the solidifying outer layers of the ingot and the still molten inner portion produces another important action.

We have seen how certain constituents of the metal may precipitate or separate out from the remainder as the temperature drops. Now with uneven temperatures throughout the ingot, it becomes evident that precipitation will occur unevenly. This in turn results in an uneven distribution of the precipitate (the material that precipitates out).

Since these precipitates may have an exceptionally important influence on the characteristics of the metal, it is essential that they be uniformly distributed throughout the entire body of the metal. This is done by mechanically working or "kneading" the ingot supplemented by the heat treatment called "homogenizing".

Homogenizing: Let's go back for a moment to where all the metal had just solidified. Note that the crystals forming first were almost pure aluminum and that succeeding crystals contained more and more copper in the form of a richer copper-aluminum alloy. Thus the grains in the solidified metal have what is termed a "cored" structure; that is, the inside crystals near the core are much different than the outer crystals of the grain. As the metal freezes and cools to room temperature, the resulting "cast" metal possesses this undesirable cored structure. So it becomes necessary to change this structure to a more desirable one.

To do this, we resort to "solid diffusion"—a term used to denote the diffusion or spreading out or dissolving of one metal into another when both are in the solid state. It is well known that some liquids will readily dissolve into others, such as ink into water. Likewise certain liquids will readily dissolve certain solids, as water dissolves salt. But it is not so well known that certain solids can dissolve other solids.

It is a fact, however, that if a gold block and a silver block are cleaned carefully and pressed tightly together, the dividing line will gradually disappear, one metal blending or dissolving into the other. While this action will occur at room temperature, it is greatly speeded by heating both metals.

In a similar manner, the copper is

caused to diffuse throughout the metal structure by heating the metal to a temperature just under its melting point, followed by slow cooling. This treatment is known as "homogenizing." For many aluminum alloys it is done in the temperature range of 900-1000° F. By this means it is possible to overcome the tendency of certain constituents to segregate or separate to form thin and dense areas. Homogenizing thus is an aid in bringing about proper uniform distribution of the alloying elements and other constituents, and so helps in producing the desired homogenous structure.

(Continued next week)

Analysts Study Changes In Technology

Extensive research by analysts on "The Accelerated Speed of Scientific Invention" has been made available in a 2-part study totaling 62 pages. The first part of the survey shows that America's know-how has increased at a more rapid pace than the national debt structure, and that under a combination of circumstances we could not help but develop labor-saving machinery, low-cost raw materials and finished goods on a scale heretofore unknown.

Part II of the survey covers the new developments which are coming on a wider scale in the electrical, gasoline and housing industries; and those in metallurgy, food and drugs. These new developments of cutting down labor costs and increasing efficiency should be of interest to businessmen who are throwing up their hands as a result of the high costs charged by labor.

The complete survey is available at \$5 per copy from the Baxter International Economic Research Bureau, 76 William street, New York.

Proposed Standard on Grinding Wheels Drawn Up

A proposed revision of the simplified practice recommendation for grinding wheels is being distributed by National Bureau of Standards, Department of Commerce, to manufacturers, distributors and users for comment, acceptance or both. Originally promulgated in 1925 and revised several times since, it adds a number of shape types to the list, including three types for cones, four for plugs and three for wheels.

Another change is in the method of classification. Part I classifies abrasive wheels by shape types. Part II classifies shape type by their common uses. Recommended sizes for new machine design are given under each classification in Part II.

Wire ahead...

for productive payrolls



**The little-girls-who-aren't-there
get the same pay as those you see**

TODAY'S WORKERS need today's wiring. . . . Inadequate wiring, obsolete wiring, over-taxed wiring, over-extended wiring can cut operators' efficiency from 25 to 50 percent and reduce production accordingly.

To visualize the importance of adequate wiring, walk down your own production lines, mentally blank out every third

worker. Then, check with your plant power engineer, your consulting engineer, electrical contractor or power salesman and make sure there's no such handicap in your plant.

A wiring survey now, may save costly shut-downs and expensive alterations later. 40174



ANACONDA WIRE & CABLE COMPANY

The Business Trend

Industrial Activity Hits New Postwar High Mark

A NEW POSTWAR high mark for industrial production was set in the week ended Aug. 10 when STEEL's index of activity reached 150 per cent (preliminary), 2 points above the previous postwar high of 148 per cent that prevailed in the preceding three weeks.

The current level would be higher were it not for shortages of skilled labor, raw materials, and components.

At 150 per cent, the rate is 50 points higher than the 1936-1939 weekly average, and 48 points above the level at the end of the war a year ago.

The rise in the week ended Aug. 10 resulted from gains in steel ingot production and electric power output.

STEEL—Steel ingot production is now at about 90 per cent of capacity and is held by a scrap shortage from advancing further. Electric power output in the past month has been running higher than at any time since the end of war a year ago, and in the week ended Aug. 10 reached another new postwar high.

CARLOADINGS—Railroad carloadings are practically as high as those of any of the wartime period. There is little likelihood, however, of any appreciable increase in carloadings in the near future because of a lack of cars, particularly box cars. The car shortage is expected to become even more acute in September and October, traditionally the heaviest loading months of the year.

There is some encouragement, however, in a report from the American Railway Car Institute that deliveries of railway freight cars and new orders placed for cars rose in July over June. Orders placed in July for freight cars totaled 11,086 cars, compared with 3064 in June. July deliveries totaled 2570 cars, considerably below the capacity of the industry but above the 2094 delivered in June.

AUTOS—For the past three weeks automobile production has been slipping as a result of strikes in suppliers' plants. In the week ended Aug. 10 total car production was 78,597, indicating that a forecasted August production of 405,000 cars will not be achieved.

COAL—Production of bituminous coal continues at a high level, with output in the week ended Aug. 3 estimated at 12,245,000 tons, compared with 11,214,000 tons in the corresponding week a year ago. Production in the week ended July 27 was 12,450,000 tons. From Jan. 1 through Aug. 3 production was approximately 291,515,000 tons, which is 60,447,000 tons, or 17.2 per cent, behind that for the corresponding period of last year.

PRICES—Wholesale prices rose 0.7 per cent during the week ended Aug. 3, with varied price movements following reinstatement of government price control. This rise pushed the U. S. Bureau of Labor Statistics index of commodity prices in primary markets to 125.0 per cent of the 1926 average, 10.9 per cent above the end of June when price controls lapsed. Average prices of all commodities other than farm products and foods are now 3.6 per cent higher than at the end of June.

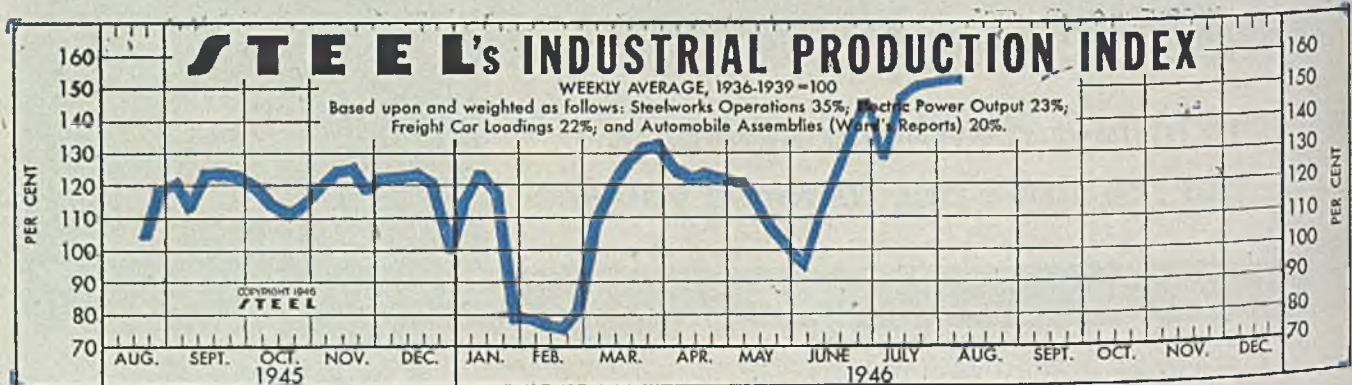

The Index (see chart above):

Latest Week (preliminary) 150

Previous Week 148

Month Ago 144

FIGURES THIS WEEK

INDUSTRY

INDUSTRY	Latest Period*	Prior Week	Month Ago	Year Ago
Steel Ingot Output (per cent of capacity)§	89	88.5	86	83.5
Electric Power Distributed (million kilowatt hours)	4,412	4,351	4,156	4,395
Bituminous Coal Production (daily av.—1000 tons)	2,011	2,073	1,995	1,869
Petroleum Production (daily av.—1000 bbls.)	4,821	4,881	4,934	4,934
Construction Volume (ENR—Unit \$1,000,000)	\$119.6	\$115.7	\$150.6	\$30.2
Automobile and Truck Output (Ward's—number units)	78,597	79,385	74,015	20,790

* Dates on request. † 1946 weekly capacity is 1,762,381 net tons. 1945 weekly capacity was 1,831,630 net tons.

TRADE

Freight Carloadings (unit—1000 cars)	900†	898	895	870
Business Failures (Dun & Bradstreet, number)	27	14	15	8
Money in Circulation (in millions of dollars)‡	\$28,326	\$28,245	\$28,335	\$27,269
Department Store Sales (change from like wk. a yr. ago)‡	+30%	+33%	+26%	+18%

† Preliminary. ‡ Federal Reserve Board.

Iron Ore

(Lake Superior Iron Ore Assn.)
Gross tons—000 omitted

	Consumption		Stocks at Lake Erie Docks and furnaces	
	1940	1945	1946	1945
Jan.	3,719	6,983	35,342	30,889
Feb.	1,748	6,371	33,647	21,577
Mar.	6,021	7,082	27,601	17,304
Apr.	4,769	6,642	23,079	16,429
May	2,990	6,872	23,905	20,715
June	4,995	6,397	26,205	24,817
July	6,532	29,485
Aug.	5,658	31,781
Sept.	5,837	39,549
Oct.	4,491	45,090
Nov.	5,611	44,700
Dec.	6,099	39,059
Total	74,576

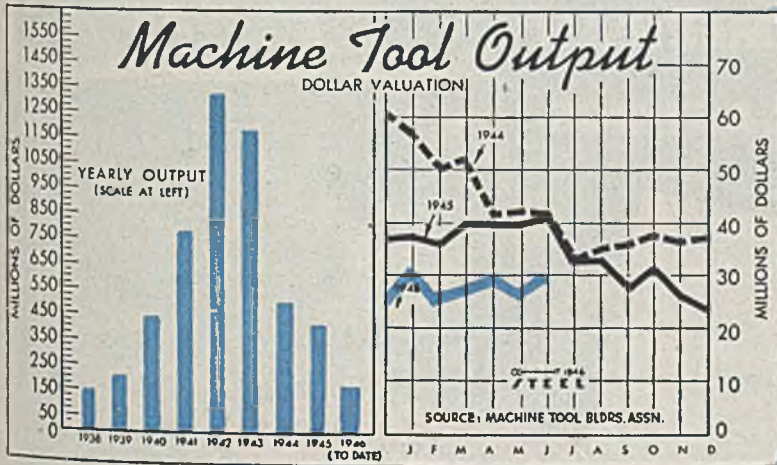
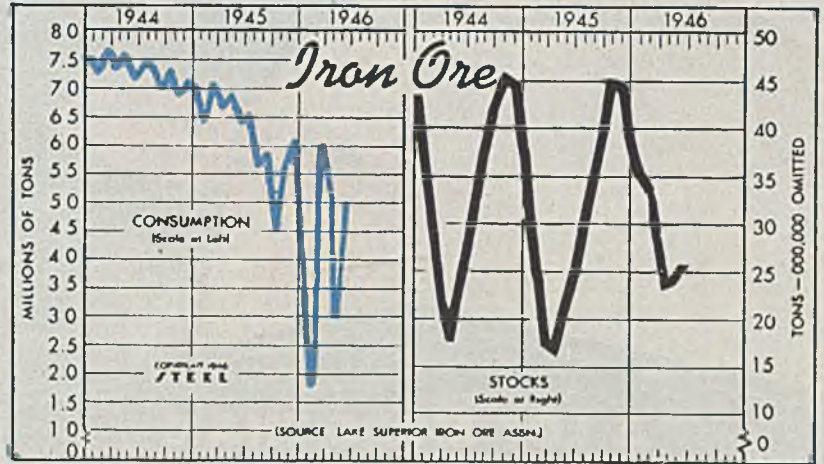

Machine Tool Shipments

(000 omitted)

	1946	1945	1944	1943
Jan.	\$30,263	\$37,353	\$58,363	\$117,384
Feb.	26,949	36,018	50,138	114,594
Mar.	27,326	40,045	51,907	123,443
Apr.	28,108	40,170	41,370	118,024
May	28,580	39,825	41,819	113,859
June	28,580	41,010	41,471	108,736
July	32,504	32,753	97,541
Aug.	32,500	35,177	87,805
Sept.	27,300	35,889	85,842
Oct.	81,200	37,516	78,302
Nov.	26,000	36,277	71,811
Dec.	23,200	36,784	60,873
Total	\$407,155	\$497,464	\$1,180,216

Factory Employment

(000 omitted)

	1946	1945	1944
January	12,038	15,555	16,823
February	11,393	15,517	16,735
March	12,014	15,368	16,559
April	12,548	15,102	16,309
May	12,655	14,811	16,122
June	12,771	14,538	16,093
July	14,130	16,018
August	13,831	16,023
September	12,097	15,843
October	11,941	15,692
November	11,947	15,607
December	11,914	15,632
Monthly Ave.	13,896	16,121

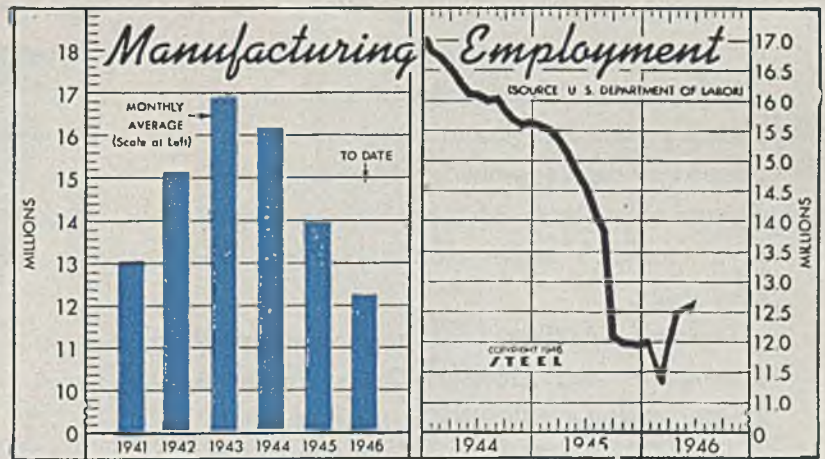

FINANCE

	Latest Period*	Prior Week	Month Ago	Year Ago
Bank Clearings (Dun & Bradstreet—millions)	\$11,791	\$11,730	\$10,738	\$10,837
Federal Gross Debt (billions)	\$267.5	\$269.6	\$268.2	\$262.7
Bond Volume, NYSE (millions)	\$15.6	\$18.4	\$17.8	\$25.2
Stocks Sales, NYSE (thousands)	4 * 2	4 127	4,501	5,335
Loans and Investments (billions)†	\$60.7	\$60.5	\$61.0	\$63.7
United States Gov't. Obligations Held (millions)†	\$42,296	\$42,666	\$42,744	\$47,000

† Member banks, Federal Reserve System.

PRICES

	Latest Period	Prior Week	Month Ago	Year Ago
STEEL's composite finished steel price average	\$64.45	\$64.45	\$64.45	\$58.97
All Commodities†	111.1	121.1	117.2	105.7
Industrial Raw Materials†	140.6	140.2	135.2	118.1
Manufactured Products†	120.6	119.3	110.9	101.9

† Bureau of Labor Statistics Index, 1926=100.

MOLDS ARE PREPARED
BY CRAFTSMEN...

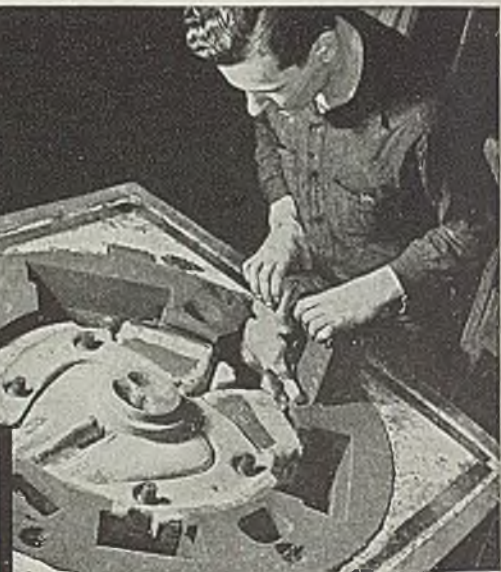

A LOT MORE THAN
Metal **GOES INTO AMERICAN**
MAGNESIUM SAND CASTINGS

You first feel the impact of American Magnesium's drive for quality as our engineers assist in designing a part to take full advantage of magnesium's weight-saving ability. They may suggest changes here or there to assure more uniform, sounder castings.

Follow the part through American Magnesium's plant and you're certain to be impressed by the know-how evidenced in every department. You're seeing nearly a quarter of a century's experience going into that production.

Designers, builders and users are invited to investigate what American Magnesium's high quality castings will do for their products. Ask the nearby Alcoa office. Or write Aluminum Company of America, Sales Agents for American Magnesium products, 1721 Gulf Building, Pittsburgh 19, Pennsylvania

A LOT OF KNOW-HOW GOES INTO
THE CASTING OF THE METAL

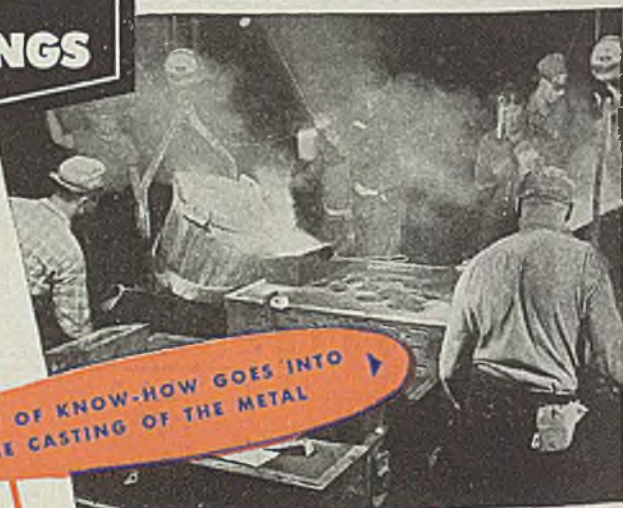

A CHECKER OK'S IT
FOR PRODUCTION



MAGNESIUM



PRODUCTS

AMERICAN MAGNESIUM CORPORATION
SUBSIDIARY OF
ALUMINUM COMPANY OF AMERICA

High Steel Production Rate Threatened by Shortages

Scrap and pig iron supply holds key to continued activity . . . Mills have little capacity for remainder of year

WHILE steel production so far this summer has held at a high rate and last week established the highest rate since July, 1945, the cumulative effect of continued shortage of pig iron and scrap is expected to be reflected in an appreciable drop shortly.

Shipments from scrap yards are down at least 50 per cent from early summer months and inventories have all but disappeared at many consuming points. This situation, combined with loss of pig iron, due to allocations for housing and agricultural requirements and other preference work, is forcing mills, some for the first time this summer, to curtail open-hearth production, and this trend will be more pronounced unless some solution is found.

In this connection much interest is being directed to the matter of scrap prices and until some action is taken on further appeals of the scrap trade for higher prices, movement of scrap is expected to continue slow. Should OPA become convinced that some advance is warranted but be unable to decide promptly how much, a promise of retroactive action would stimulate the flow, it is believed.

Pig iron production is improving slowly but this is not redounding in general to the advantage of steelmakers because of the emphasis on foundry iron for preference work.

The unsettled outlook with regard to steel production, combined with continued question as to what mills will be called on to handle in fourth quarter in the way of priority tonnage makes it difficult for producers to say when they will be in position to open books for first quarter. However, within a few weeks they will be forced to take some action. Pressure is extremely heavy from all consumers for scheduling of first quarter tonnage, although

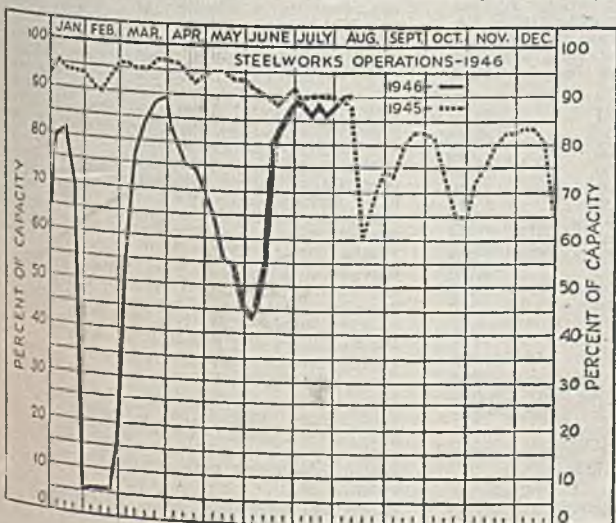

DISTRICT STEEL RATES

(Percentage of Ingot Capacity Engaged in Leading Districts)

	Week Ended		Same Week	
	Aug. 17	Change	1945	1944
Pittsburgh	98.5	+ 1	45	91.5
Chicago	92.5	+ 3	40	99
Eastern Pa.	81	- 3	77	95
Youngstown	88	None	53	95
Wheeling	93.5	+ 7.5	64.5	95
Cleveland	91.5	- 0.5	50	93
Buffalo	88.5	None	62.5	90.5
Birmingham	99	None	95	95
New England	90	+15	84	70
Cincinnati	89	None	58	92
St. Louis	54.5	+ 5	50	87
Detroit	90	+ 1	62	89
Estimated national rate	90	+ 1	60	97

Based on weekly steelmaking capacity of 1,762,381 net tons for 1946; 1,831,636 tons for 1945; 1,791,287 tons for 1944.

interest still is centered primarily in obtaining tonnage already due against current commitments. Little new tonnage can be accepted for shipment over the remainder of this year. Hot and cold-rolled alloy bars can be had in free supply, hot-rolled in late September and early October. Some large sizes of hot carbon and cold-rolled bars are available in limited tonnages for late this year.

Among the few other items that can be bought for delivery this year without priorities are wire rope and stainless steel sheets. On all other products mills are covered for the remainder of the year, either through outright sales or quota obligations, and on most products indications are they will have substantial carryovers at the end of the year. Some mills have accepted orders for first quarter in certain products, including plates, track accessories, mechanical and boiler tubing, and a certain amount of steel required for identified projects. In the main, however, little tonnage can be placed for shipment over the remainder of this year or for shipment beyond.

In spite of difficulties steelmakers are holding a high rate of production and last week attained 90 per cent of capacity on a national basis, a rise of 1 point, highest since July, 1945. Six districts made slight gains over the preceding week and only two declined. Others held to the prior rates. Pittsburgh advanced 1 point to 98½ per cent, Wheeling 7½ points to 93½, Chicago 3 points to 92½, Detroit 1 point to 90, St. Louis 5 points to 54½ and New England 15 points to 90. Eastern Pennsylvania dropped 3 points to 81 and Cleveland ½-point to 91½. Rates were unchanged as follows: Youngstown 88, Cincinnati 89, Birmingham 99, Buffalo 88½ and West Coast 84.

Steel ingot production in July was largest since July last year, output being 6,598,864 net tons, compared with 5,624,826 tons in June and 6,985,571 tons in July, 1945. Production to Aug. 1 this year was 33,928,018 tons, compared with 50,128,653 tons in the comparable period in 1945. This discrepancy emphasizes the effects of the steel and coal strikes of early months and the shortage of scrap and pig iron in later months.

COMPOSITE MARKET AVERAGES

	Aug. 17	Aug. 10	Aug. 3	One Month Ago July, 1946	Three Months Ago May, 1946	One Year Ago Aug., 1945	Five Years Ago Aug., 1941
Finished Steel	\$64.45	\$64.45	\$64.45	\$64.45	\$63.54	\$58.27	\$56.73
Semifinished Steel	40.60	40.60	40.60	40.60	40.60	37.80	36.00
Steelmaking Pig Iron	27.50	27.50	27.50	27.50	25.50	24.00	23.00
Steelmaking Scrap	19.17	19.17	19.17	19.17	19.17	19.17	19.17

Finished Steel Composite:—Average of industry-wide prices on sheets, strips, bars, plates, shapes, wire, nails, tin plate, standard and line pipe. Semifinished Steel Composite:—Average of industry-wide prices on billets, slabs, sheet bars, skelp and wire rods. Steelmaking Pig Iron Composite:—Average of basic pig iron prices at Bethlehem, Birmingham, Buffalo, Chicago, Cleveland, Neville Island, Granite City and Youngstown. Steelworks Scrap Composite:—Average of No. 1 heavy melting steel prices at Pittsburgh, Chicago and eastern Pennsylvania. Finished steel, net tons; others, gross tons.

COMPARISON OF PRICES

Representative Market Figures for Current Week; Average for Last Month, Three Months and One Year Ago

Finished material (except tin plate) and wire rods, cents per lb; coke, dollars per net ton; others, dollars per gross ton.

Finished Material

	Aug. 17, 1946	July, 1946	May, 1946	Aug., 1945
Steel bars, Pittsburgh	2.50c	2.50c	2.50c	2.25c
Steel bars, Philadelphia	2.86	2.86	2.82	2.57
Steel bars, Chicago	2.50	2.50	2.50	2.25
Shapes, Pittsburgh	2.35	2.35	2.35	2.10
Shapes, Philadelphia	2.48	2.48	2.465	2.215
Shapes, Chicago	2.35	2.35	2.35	2.10
Plates, Pittsburgh	2.50	2.50	2.50	2.25
Plates, Philadelphia	2.558	2.558	2.55	2.30
Plates, Chicago	2.50	2.50	2.50	2.25
Sheets, hot rolled, Pittsburgh	2.425	2.425	2.425	2.20
Sheets, cold-rolled, Pittsburgh	3.275	3.275	3.275	3.05
Sheets, No. 24 galv., Pittsburgh	4.05	4.05	4.05	3.70
Sheets, hot-rolled, Gary	2.425	2.425	2.425	2.20
Sheets, cold-rolled, Gary	3.275	3.275	3.275	3.05
Sheets, No. 24 galv., Gary	4.05	4.05	4.05	3.70
Hot-rolled strip, over 6 to 12-in., Pitts.	2.35	2.35	2.35	2.10
Cold-rolled strip, Pittsburgh	3.05	3.05	3.05	2.80
Bright basic, bess. wire, Pittsburgh ..	3.05	3.05	3.05	2.75
Wire nails, Pittsburgh	3.75	3.75	3.25	2.90
Tin plate, per base box, Pittsburgh ..	\$5.25	\$5.25	\$5.25	\$5.00

Pig Iron

	Aug. 17, 1946	June, 1946	Apr., 1946	July, 1945
Bessemer del. Pittsburgh	\$29.77	\$29.69	\$27.69	\$26.19
Basic, Valley	28.00	28.00	26.00	24.50
Basic, eastern del. Philadelphia	29.93	29.93	27.84	26.34
No. 2 fdry., del. Pgh. N. & S. sides ..	29.27	29.19	27.19	25.69
No. 2 foundry, Chicago	28.50	28.50	26.50	25.00
Southern No. 2, Birmingham	24.88	24.88	22.88	21.38
Southern No. 2 del. Cincinnati	28.94	28.94	26.94	25.44
No. 2 fdry., del. Philadelphia	30.43	30.43	28.34	26.84
Malleable, Valley	28.50	28.50	26.50	25.00
Malleable, Chicago	28.50	28.50	26.50	25.00
Charcoal, low phos., fob Lyles, Tenn.	33.00	33.00	33.00	33.00
Gray forge, del. Pittsburgh	28.69	28.69	26.69	25.19
Ferromanganese, fob cars, Pittsburgh	140.00	140.00	140.00	140.33

Scrap

	Aug. 17, 1946	June, 1946	Apr., 1946	July, 1945
Heavy melting steel, No. 1, Pittsburgh	\$20.00	\$20.00	\$20.00	\$20.00
Heavy melt, steel, No. 2, E. Pa.	18.75	18.75	18.75	18.75
Heavy melting steel, Chicago	18.75	18.75	18.75	18.75
Rails for rolling, Chicago	22.25	22.25	22.25	22.25
No. 1 cast, Chicago	20.00	20.00	20.00	20.00

Coke

	Aug. 17, 1946	June, 1946	Apr., 1946	July, 1945
Connellsville, furnace ovens	\$8.75	\$8.75	\$7.50	\$7.50
Connellsville, foundry ovens	9.50	9.50	8.25	8.25
Chicago, by-product fdry., del.	15.10	15.10	13.75	13.67

Semifinished Material

	Aug. 17, 1946	July, 1946	May, 1946	Aug., 1945
Sheet bars, Pittsburgh, Chicago	\$38.00	\$38.00	\$38.00	\$36.00
Slabs, Pittsburgh, Chicago	39.00	39.00	39.00	36.00
Rerolling billets, Pittsburgh	39.00	39.00	39.00	36.00
Wire rods, No. 5 to 3/4-inch, Pitts.	2.30c	2.30c	2.30c	2.15c

STEEL, IRON, RAW MATERIAL, FUEL AND METALS PRICES

Finished steel quoted in cents per pound and semifinished in dollars per gross ton, except as otherwise noted. Delivered prices do not include the 3 per cent federal tax on freight. Pricing on rails was changed to net ton basis as of Feb. 15 1946.

Semifinished Steel

Carbon Steel Ingots: Fob mill base, rerolling quality, standard analysis, \$33.

Alloy Steel Ingots: Pittsburgh, Chicago, Buffalo, Bethlehem, Canton, Massillon; uncrp, \$48.69.

Rerolling, Billets, Blooms, Slabs: Pittsburgh, Chicago, Gary, Cleveland, Buffalo, Sparrows Point, Birmingham, Youngstown, \$39; Detroit, del., \$41; Duluth (billets), \$41; Pac. ports (billets), \$51. (Andrews Steel Co., carbon slabs, \$41; Northwestern Steel & Wire Co., \$41, Sterling, Ill.; Granite City Steel Co., \$47.50 gross ton slabs from D.P.C. mill. Geneva Steel Co., \$53.64, Pac. ports.)

Forging Quality Blooms, Slabs, Billets: Pittsburgh, Chicago, Gary, Cleveland, Buffalo, Birmingham, Youngstown, \$47; Detroit, del., \$49; Duluth, billets, \$49; forging billets fob Pac. ports, \$59.

(Andrews Steel Co. may quote carbon forging billets \$50 gross ton at established basing points; Follansbee Steel Corp., \$49.50 fob Toronto, O.; Geneva Steel Co., \$64.64, Pacific ports.)

Alloy Billets, Slabs, Blooms: Pittsburgh, Chicago, Buffalo, Bethlehem, Canton, Massillon, \$53.43; del. Detroit \$60.43; eastern Mich. \$61.43.

Sheet Bars: Pittsburgh, Chicago, Cleveland, Buffalo, Canton, Sparrows Point, Youngstown, \$38. (Empire Sheet & Tin Plate Co., Mansfield, O., carbon sheet bars, \$39, fob mill.)

Skelp: Pittsburgh, Chicago, Sparrows Point, Youngstown, Coatesville, lb, 2.05c.

Wire Rods: Pittsburgh, Chicago, Cleveland, Birmingham, No. 5—3/4 in. inclusive, per 100 lb, \$2.30. Do., over 3/4—1 1/4 in., incl., \$2.45; Galveston, base, \$2.40 and \$2.55, respectively. Worcester add \$0.10; Pacific ports \$0.50.

Bars

Hot-Rolled Carbon Bars and Bar-Size Shapes under 3-in.: Pittsburgh, Youngstown, Chicago, Gary, Cleveland, Buffalo, Birmingham base, 20 tons one size, 2.50c; Duluth, base, 2.60c; Detroit, del., 2.60c; eastern Mich., 2.65c; New York, del., 2.86c; Phila., del., 2.86c; Gulf ports, dock, 2.85c; Pac. ports, dock, 3.15c. (Sheffield Steel Corp. may quote 2.75c, fob St. Louis; Joslyn Mfg. & Supply Co., 2.55c, fob Chicago.)

Rail Steel Bars: Same prices as for hot-rolled carbon bars except base is 5 tons.

Hot-Rolled Alloy Bars: Pittsburgh, Youngstown, Chicago, Canton, Massillon, Buffalo, Bethlehem, base 20 tons one size, 2.921c; Detroit, del., 3.021c. (Texas Steel Co. may use Chicago base price as maximum fob Fort Worth, Tex., price on sales outside Texas, Oklahoma.)

AISI Series	(*Basic O-H)	AISI Series	(*Basic O-H)
1300	\$0.108	4300	\$1.839
2300	1.839	4600	1.298
2500	2.759	4800	2.326
3000	0.541	5100	0.379
3100	0.920	5130 or 5152 ..	0.494
3200	1.461	6120 or 6152 ..	1.028
		6145 or 6150 ..	1.298
		8612	0.703
		8720	0.737
		9830	1.407

* Add 0.25 for acid open-hearth; 0.50 electric.

Cold-Finished Carbon Bars: Pittsburgh, Chicago, Gary, Cleveland, Buffalo, base, 20,000-39,999 lb, 3.10c; Detroit, 3.15c; Toledo, 3.25c.

Cold-Finished Alloy Bars: Pittsburgh, Chicago, Gary, Cleveland, Buffalo, base, 3.625c; Detroit, del., 3.725c, eastern Mich., 3.755c.

Reinforcing Bars (New Billet): Pittsburgh, Chicago, Gary, Cleveland, Birmingham, Sparrows Point, Buffalo, Youngstown, base, 2.35c;

Detroit, del., 2.45c; eastern Mich. and Toledo, 2.50c; Gulf ports, dock, 2.70c; Pacific ports, dock, 2.75c.

Reinforcing Bars (Rail Steel): Pittsburgh, Chicago, Gary, Cleveland, Birmingham, Youngstown, Buffalo, base, 2.35c; Detroit, del., 2.45c; eastern Mich. and Toledo, del., 2.50c; Gulf ports, dock, 2.70c.

Iron Bars: Single refined, Pitts., 4.76c; double refined, 5.84c; Pittsburgh, staybolt, 6.22c; Terre Haute, single ref., 5.42c; double ref., 6.76c.

Sheets, Strip

Hot-Rolled Sheets: Pittsburgh, Chicago, Gary, Cleveland, Birmingham, Buffalo, Youngstown, Sparrows Pt., Middletown, base, 2.425c; Granite City, base, 2.525c; Detroit, del., 2.615c; eastern Mich., del., 2.575c; Phila., del., 2.615c; New York, del., 2.685c; Pacific ports, 2.975c. (Andrews Steel Co. may quote hot-rolled sheets for shipment to the Detroit area on the Midland, O., base; Alan Wood Steel Co., Conshohocken, Pa., may quote 3.00c on hot carbon sheets, Sparrows Point, Md.)

Cold-Rolled Sheets: Pittsburgh, Chicago, Cleveland, Gary, Buffalo, Youngstown, Middletown, base, 3.275c; Granite City, base, 3.375c; Detroit, del., 3.375c; eastern Mich., del., 3.425c; New York, del., 3.615c; Phila., del., 3.655c; Pacific ports, 3.925c.

Galvanized Sheets, No. 24: Pittsburgh, Chicago, Gary, Birmingham, Buffalo, Youngstown, Sparrows Point, Middletown, base, 4.05c; Granite City, base, 4.15c; New York, del., 4.31c; Phila., del., 4.24c; Pacific ports, 4.60c.

Corrugated Galv. Sheets: Pittsburgh, Chicago, Gary, Birmingham, 29-gage, per square, 3.73c.

Culvert Sheets: Pittsburgh, Chicago, Gary, Birmingham, 16-gage not corrugated, copper alloy, 4.15c; Granite City, 4.25c; Pacific ports, 4.60c; copper iron, 4.50c; pure iron, 4.50c; zinc-coated, hot-dipped, heat-treated, No. 24, Pittsburgh, 4.60c.

Aluminized Sheets, 20 gage: Pittsburgh, hot-dipped, coils or cut to lengths, 9.00c.

Enameling Sheets: 10-gage; Pittsburgh, Chicago, Gary, Cleveland, Youngstown, Middletown, base 3.20c; Granite City, base 3.30c; Detroit, del., 3.30c; eastern Mich., 3.35c; Pacific ports, 3.85c; 20-gage; Pittsburgh, Chicago, Gary, Cleveland, Youngstown, Middletown, base, 3.80c; Detroit, del., 3.90c; eastern Mich., 3.95c; Pacific ports, 4.45c.

Electrical Sheets No. 24:

	Pittsburgh	Pacific	Granite
	Base	Ports	City
Field grade	3.90c	4.65c	4.00c
Armature	4.25c	5.00c	4.35c
Electrical	4.75c	5.50c	4.85c
Motor	5.425c	6.175c	5.525c
Dynamo	6.125c	6.875c	6.225c
Transformer			
72	6.625c	7.375c	
65	7.625c	8.375c	
58	8.125c	8.875c	
52	8.925c	9.675c	

Hot-Rolled Strip: Pittsburgh, Chicago, Gary, Cleveland, Birmingham, Youngstown, Middletown, 6-in. and narrower: Base, 2.45c; Detroit, del., 2.55c; eastern Mich., del., 2.60c; Pacific ports, 3.10c. (Superior Steel Corp. may quote 3.30c, Pitts.)

Over 6-in.: Base, 2.35c; Detroit, del., 2.45c; eastern Mich., del., 2.50c; Pacific ports, 3.00c. (Superior Steel Corp. may quote 3.20c, Pitts.)

Cold-Rolled Strip: Pittsburgh, Cleveland, Youngstown, 0.25 carbon and less, 3.05c; Chicago, base, 3.15c; Detroit, del., 3.15c; eastern Mich., del., 3.20c; Worcester, base, 3.25c. (Superior Steel Corp. may quote 4.70c, Pitts.)

Cold-Finished Spring Steel: Pittsburgh, Cleveland base, 0.26-0.50 carbon, 3.03c. Add 0.20c for Worcester.

Tin, Terne Plate

(OPA ceiling prices announced March 1, 1946.)
Tin Plate: Pittsburgh, Chicago, Gary, 100-lb base box, \$5.25; Granite City, Birmingham, Sparrows Point, \$5.35.
Electrolytic Tin Plate: Pittsburgh, Gary, 100-lb base box, 0.25 lb tin, \$4.60; 0.50 lb tin, \$4.75; 0.75 lb tin, \$4.90; Granite City, Birmingham, Sparrows Point, \$4.70, \$4.85, \$5.00, respectively.

Tin Mill Black Plate: Pittsburgh, Chicago, Gary, base 29-gage and lighter, 3.30c; Granite City, Birmingham, Sparrows Point, 3.40c; Pacific ports, boxed, 4.30c.

Iron Terns: Pittsburgh, Chicago, Gary, No. 24 unassorted, 4.05c; Pacific ports, 4.80c.

Manufacturing Terns (Special Coated): Pittsburgh, Chicago, Gary, 100-base box, \$4.55; Granite City, Birmingham, Sparrows Point, \$4.65.

Roofing Terns: Pittsburgh base per package 112 sheets; 20 x 28 in., coating I. C. 8-lb \$12.50; 15-lb \$14.50; 20-lb \$15.50 (nom.); 40-lb \$20.00 (nom.)

Plates

Carbon Steel Plates: Pittsburgh, Chicago, Gary, Cleveland, Birmingham, Youngstown, Sparrows Point, Coatesville, Claymont, 2.50c; New York, del., 2.71c; Phila., del., 2.558c; St. Louis, 2.74c; Boston, del., 2.86c; Pacific ports, 3.05c; Gulf ports, 2.85c.

(Granite City Steel Co. may quote carbon plates 2.65c fob D.P.C. mill; Geneva Steel Co., Provo, Utah, 3.20c fob Pac. ports; Central Iron & Steel Co., Harrisburg, Pa., 2.80c, basing points; Lukens Steel Co., Coatesville, Pa., 2.75c, base; Worth Steel Co., Claymont, Del., 2.60c, base; Allen Wood Steel Co., Conshohocken, Pa., 2.75c base.)

Floor Plates: Pittsburgh, Chicago, 3.75c; Pacific ports, 4.40c; Gulf ports, 4.10c.

Open-Heath Alloy Plates: Pittsburgh, Chicago, Coatesville, 3.787c; Gulf ports, 4.273c; Pacific ports, 4.49c.

Clad Steel Plates: Coatesville, 10% cladding; nickel-clad, 18.72c; inconel-clad, 26.00c; monel-clad, 24.96c.

Shapes

Structural Shapes: Pittsburgh, Chicago, Gary, Birmingham, Buffalo, Bethlehem, 2.35c; New York, del., 2.54c; Phila., del., 2.48c; Pacific ports, 3.00c; Gulf ports, 2.70c.

(Phoenix Iron Co., Phoenixville, Pa., may quote the equivalent of 2.60c. Bethlehem, Pa., on the general range and 2.70c on beams and channels from 4 to 10 inches.)

Steel Piling: Pittsburgh, Chicago, Buffalo, 2.65c; Pacific ports, 3.20c.

Wire and Wire Products

(Fob Pittsburgh, Chicago, Cleveland and Birmingham, per 100 pounds)

Wire to Manufacturers in carloads	\$3.05
Spring (except Birmingham)	\$4.00
Wire Products to Trade	
Nails and staples	
Standard and cement-coated	\$3.75
Galvanized	\$3.40
Wire, Merchant Quality	
Annealed	\$3.50
Galvanized	\$3.85

(Fob Pittsburgh, Chicago, Cleveland, Birmingham, per base column)

Woven fence, 15 1/2 gage and heavier	72
Barbed wire, 80-rod spool	**79
Barless wire, twisted	**79
Fence posts	74
Bale ties, single loop	72 1/2

*Add \$0.10 for Worcester, \$0.05 for Duluth and \$0.50 for Pacific ports.

†Add \$0.30 for Worcester, \$0.50 for Pacific ports. Nichols Wire & Steel may quote \$4.25; Pittsburgh Steel Co., \$4.10.

‡Add \$0.50 for Pacific ports.

§Add \$0.10 for Worcester; \$0.70 Pacific ports. **Pittsburgh Steel Co. may quote 89.

Tubular Goods

Welded Pipe: Base price in carloads, threaded and coupled to consumers about \$200 per net ton. Base discounts on steel pipe Pittsburgh and Lorain, O.; Gary, Ind., 2 points less on lap weld, 1 point less on butt weld. Pittsburgh base only on wrought iron pipe.

Steel			Iron		
In.	Blk.	Galv.	In.	Blk.	Galv.
1/4	53	30	1/4	21	0 1/2
3/8	56	37 1/2	3/8	27	7
1/2	60 1/2	48	1-1/4	31	13
3/4	63 1/2	52	1 1/2	35	15 1/2
1-3	65 1/2	54 1/2	2	34 1/2	15

Roller Tubes: Net base prices per 100 feet fob Pittsburgh in carload lots, minimum wall, cut lengths 4 to 24 feet, inclusive.

Steel			Iron		
In.	Blk.	Galv.	In.	Blk.	Galv.
2	58	46 1/2	1 1/4	20	0 1/2
2 1/2-3	61	49 1/2	1 1/2	25 1/2	7
3 1/2-6	63	51 1/2	2	27 1/2	9
7-8	62	49 1/2	2 1/2-3 1/4	28 1/2	11 1/2
9-10	61 1/2	49	4	30 1/2	15
11-12	60 1/2	48	4 1/2-8	29 1/2	14
			9-12	25 1/2	9

—Seamless—			—Elec. Weld—		
O.D. sizes	Hot Rolled	Cold Drawn	Hot Rolled	Cold Rolled	
1"	13	\$9.90	\$9.36	\$9.65	
1 1/4"	13	11.73	9.63	11.43	
1 1/2"	13	\$10.91	12.96	10.63	12.64
1 3/4"	13	12.41	14.75	12.10	14.37
2"	13	13.90	16.52	13.53	16.19
2 1/4"	13	15.50	18.42	15.06	18.03
2 1/2"	12	17.07	20.28	16.57	19.83
2 3/4"	12	18.70	22.21	18.11	21.68
3"	12	19.82	23.51	19.17	22.95
3 1/4"	12	20.79	24.71	20.05	24.02
3 1/2"	11	26.24	31.18	25.30	30.29
4"	10	32.56	38.68	31.32	37.52
4 1/2"	9	43.16	51.29		
5"	9	49.96	59.36		
6"	9	76.71	91.34		

Plp., Cast Iron: Class B, 6-in. and over, \$60 per net ton, Birmingham; \$65, Burlington, N. J.; \$62.80, del., Chicago; 4-in. pipe, \$5 higher. Class A pipe, \$3 a ton over class B.

Rails, Supplies

Standard rails, over 60-lb, fob mill, net ton, \$43.40. Light rails (billet), Pittsburgh, Chicago, Birmingham, net ton, \$49.18.

Relaying rails, 35 lb and over, fob railroad and basing points, \$31-\$33.

Supplies: Track bolts, 6.50c; heat treated, 6.75c. Tie plates \$51 net ton, base, Standard spikes, 3.65c.

Bolts, Nuts

Fob Pittsburgh, Cleveland, Birmingham, Chicago. Additional discounts: 5 for carloads; 10 for full containers, except tire, step and plow bolts.

(Ceiling prices advanced 12 per cent, effective July 27, 1946; discounts remain unchanged.)

Carriage and Machine		
1/2 x 6 and smaller		65 1/2 off
Do., 3/8 and 5/8 x 6-in. and shorter		63 1/2 off
Do., 3/4 to 1 x 6-in. and shorter		61 off
1 1/4 and larger, all lengths		59 off
All diameters, over 6-in. long		59 off
Tire bolts		50 off
Step bolts		56 off
Plow bolts		65 off

Stove Bolts

In packages, nuts separate, 71-10 off, nuts attached, 71 off; bulk, 80 off on 15,000 of 3-in. and shorter, or 5000 over 3 in., nuts separate.

	Nuts	U.S.S.	S.A.E.
Semifinished hex			
3/8-in. and smaller			64
1/2-in. and smaller		62	
3/4-in.-1-in.			60
1 1/4-in.-1-in.		59	
1 1/2-in.-1 1/2-in.		57	58
1 3/4-in. and larger		56	
Additional discount of 10 for full kegs.			

Hexagon Cap Screws
 Upset 1-in., smaller 64 off
 Milled 1-in., smaller 60 off

Square Head Set Screws
 Upset 1-in. and smaller 71 off
 Headless, 3/4-in. and larger 60 off
 No. 10 and smaller 70 off

Rivets

Fob Pittsburgh, Cleveland, Chicago, Birmingham
 Structural 4.75c
 3/8-inch and under *65-5 off
 *Plus 12 per cent increase on base prices, effective July 26.

Washers, Wrought

Fob Pittsburgh, Chicago, Philadelphia, to jobbers and large nut and bolt manufacturers, 1cl \$2.75-\$3.00 off

Tool Steels

Tool Steels: Pittsburgh, Bethlehem, Syracuse, Canton, O., Dunkirk, N. Y., base, cents per lb; reg. carbon 15.15c; extra carbon 19.48c; special carbon 23.80c; oil-hardening 25.97c; high carbon-chromium 46.53c.

W	Cr.	V.	Mo.	Base, per lb.
18.00	4	1		72.49c
1.5	4	1	8.5	58.43c
	4	2	3	58.43c
6.40	4.15	1.90	5	62.22c
5.50	4.50	4	4.50	75.74c

Stainless Steels

Base, Cents per lb				
CHROMIUM NICKEL STEELS				
	Bars	Plates	Sheet's	Strip
302	25.96c	29.21c	36.79c	23.93c
303	28.13	31.38	38.95	29.21
304	27.05	31.38	38.95	25.45
308	31.38	36.79	44.96	30.84
309	38.95	43.28	50.85	40.03
310	53.02	56.26	57.35	52.74
312	38.95	43.28	53.02	
*316	43.28	47.61	51.94	43.28
†321	31.38	36.79	44.36	31.65
†347	35.71	41.12	48.69	35.71
431	20.56	23.80	31.38	18.94

STRAIGHT CHROMIUM STEEL				
	Hot Rolled	Hot Rolled	Hot Rolled	Hot Rolled
403	23.93	26.51	31.92	22.99
*410	20.02	23.93	28.67	18.89
416	20.56	23.80	29.21	19.75
†420	25.96	30.84	36.25	25.70
430	20.56	23.80	31.38	18.94
†430F	21.10	24.35	31.92	20.29
440A	25.96	30.84	36.25	25.70
442	24.35	27.59	35.17	25.96
443	24.35	27.59	35.17	25.96
446	29.76	33.00	39.49	37.87
501	8.66	12.98	17.04	12.98
502	9.74	14.07	18.12	14.07

STAINLESS CLAD STEEL (20%)
 (Fob Pittsburgh and Washington, Pa., plate prices include annealing and pickling.)

304	19.48	20.56
410	17.31	18.39
430	17.85	18.94
446	19.48	20.56

* With 2-3% molybdenum. † With titanium. ‡ With columbium. ** Plus machining agent †† High carbon. ‡‡ Free machining.

Metallurgical Coke

Price Per Net Ton	
Beehive Ovens	
Connellsville, furnace	\$7.50
Connellsville, foundry	8.50- 8.75
New River, foundry	9.00- 9.25
Wise county, foundry	7.75- 8.25
Wise county, furnace	7.25- 7.75

By-Product Foundry	
Kearney, N. J., ovens	14.40
Chicago, outside delivered	14.35
Chicago, delivered	15.10
Terre Haute, delivered	14.85
Milwaukee, ovens	15.10
New England, delivered	16.00
St. Louis, delivered	115.10
Birmingham, delivered	12.25
Indianapolis, delivered	14.85
Cincinnati, delivered	14.60
Cleveland, delivered	14.55
Buffalo delivered	14.75
Philad., delivered	15.10
Philadelphia, delivered	14.63

†15.68 from other than Ala., Mo., Tenn.

Coke By-Products

Spot, gal, freight allowed east of Omaha	15.00c
Pure and 90% benzol	22.00c
Toluol, two degree	22.00c
Industrial xylol	22.00c
Per pound fob works	
Phenol (car lots, returnable drums)	11.25c
Do., less than carlots	12.00c
Do., tank cars	10.25c
Eastern plants, per pound	
Naphthalene flakes, balls, bbl, to jobbers, "household use"	9.00c
Per ton, bulk, fob plants	
Sulphate of ammonia	\$30.00

WAREHOUSE STEEL PRICES

Base delivered price, cents per pound, for delivery within switching limits, subject to established extras. Quotations based on mill prices announced March 1, 1946

	Hot-rolled bars	Structural shapes	Plates	Floor plates	Hot-rolled sheets (10-gage base)	Hot-rolled strip (24-gage and lighter, 6-in and narrower)	Hot-rolled strip (12-gage and heavier, wider than 6-inch)	Galvanized flat sheets (24-gage base)	Cold-rolled sheets (17-gage base)	Cold-finished bars	Cold-rolled strip
Boston	4.356 ¹	4.203 ¹	4.203 ¹	6.039 ¹	4.050 ¹	5.548 ¹	4.418 ¹	5.725 ¹⁴	5.031 ¹⁴	4.856 ²¹	4.965
New York	4.134 ¹	4.038 ¹	4.049 ¹	5.875 ¹	3.856 ¹	4.375 ¹	4.275 ¹	5.501 ¹²	4.838 ¹⁴	4.584 ²¹	5.075
Jersey City	4.155 ¹	4.018 ¹	4.049 ¹	5.875 ¹	3.856 ¹	4.375 ¹	4.275 ¹	5.501 ¹²	4.890 ¹⁴	4.605 ²¹	5.075
Philadelphia	4.114 ¹	3.937 ¹	3.875 ¹	5.564 ¹	3.774 ¹	4.664 ¹	4.554 ¹	5.499 ¹²	5.139 ¹⁵	4.564 ²¹	5.064
Baltimore	4.093 ¹	4.05 ¹	3.865 ¹	5.543 ¹	3.64 ¹	4.293 ¹	4.193 ¹	5.365 ¹⁷	5.118 ¹⁶	4.543 ²¹
Washington	4.232 ¹	4.22 ¹	4.067 ¹	5.632 ¹	3.842 ¹	4.432 ¹	4.332 ¹	5.667 ¹⁷	5.007 ²⁴	4.532 ²¹
Norfolk, Va.	4.377 ¹	4.303 ¹	4.262 ¹	5.777 ¹	4.037 ¹	4.927 ¹	4.477 ¹	5.862 ¹⁷	5.552 ²⁴	4.677 ²¹
Bethlehem, Pa. ^o	3.70 ¹
Claymont, Del. ^o	3.70 ¹
Coatesville, Pa. ^o	3.70 ¹
Buffalo (city)	3.60 ¹	3.65 ¹	3.92 ¹	5.55 ¹	3.575 ¹	4.21 ¹	4.11 ¹	5.20 ¹³	4.625 ¹⁶	4.20 ²¹	4.96
Buffalo (country)	3.50 ¹	3.55 ¹	3.55 ¹	5.15 ¹	3.475 ¹	3.85 ¹	3.750 ¹	5.10 ¹³	4.525 ¹⁶	4.10 ²¹	4.60
Pittsburgh (city)	3.60 ¹	3.65 ¹	3.65 ¹	5.25 ¹	3.575 ¹	3.95 ¹	3.850 ¹	5.327 ¹²	4.625 ¹⁶	4.20 ²¹	4.70
Pittsburgh (country)	3.50 ¹	3.55 ¹	3.55 ¹	5.15 ¹	3.475 ¹	3.85 ¹	3.750 ¹	5.10 ¹³	4.525 ¹⁶	4.10 ²¹	4.60
Cleveland (city)	3.60 ¹	3.88 ¹	3.65 ¹	5.48 ¹	3.575 ¹	3.95 ¹	3.850 ¹	5.347 ¹²	4.625 ¹⁶	4.20 ²¹	4.70
Cleveland (country)	3.50 ¹	3.55 ¹	3.55 ¹	5.48 ¹	3.475 ¹	3.85 ¹	3.750 ¹	5.347 ¹²	4.525 ¹⁶	4.10 ²¹	4.60
Detroit	3.70 ¹	3.952 ¹	3.90 ¹	5.572 ¹	3.675 ¹	4.050 ¹	3.950 ¹	5.491 ¹²	4.725 ¹⁶	4.25 ²¹	4.95
Omaha (city, del.)	4.32 ¹	4.37 ¹	4.37 ¹	5.97 ¹	4.045 ¹	4.52 ¹	4.42 ¹	6.00 ¹⁵	5.72 ²⁴	4.945 ²¹
Omaha (country)	4.22 ¹	4.27 ¹	4.27 ¹	5.87 ¹	3.945 ¹	4.42 ¹	4.32 ¹	5.90 ¹⁵
Cincinnati	3.902 ¹	3.983 ¹	3.952 ¹	5.583 ¹	3.671 ¹	4.046 ¹	3.946 ¹	5.296 ¹⁵	4.271 ²⁴	4.602 ²¹
Youngstown ^o	4.85 ¹²
Middletown, O. ^o	3.475 ²	3.95 ¹	3.750 ¹	5.10 ¹³
Chicago (city)	3.75 ¹	3.80 ¹	3.80 ¹	5.40 ¹	3.475 ¹	3.95 ¹	3.850 ¹	5.40 ¹⁵	4.425 ²⁴	4.20 ²¹	4.90
Milwaukee	3.908 ¹	3.958 ¹	3.958 ¹	5.558 ¹	3.693 ¹	4.108 ¹	4.008 ¹	5.558 ¹⁵	4.583 ²⁴	4.358 ²¹	5.058
Indianapolis	3.83 ¹	3.88 ¹	3.88 ¹	5.48 ¹	3.743 ¹	4.118 ¹	4.018 ¹	5.368 ¹⁵	4.793 ²⁴	4.43 ²¹	5.030
St. Paul	4.092 ²	4.142 ²	4.142 ²	5.742 ²	3.817 ²	4.292 ²	4.192 ²	5.666 ¹⁵	4.767 ²⁴	4.852 ²¹	5.393
St. Louis	3.918 ¹	3.968 ¹	3.968 ¹	5.568 ¹	3.643 ¹	4.118 ¹	4.018 ¹	5.622 ¹⁵	4.593 ²⁴	4.522 ²¹	5.222
Memphis, Tenn.	4.296 ¹	4.346 ¹	4.346 ¹	6.071 ¹	4.221 ¹	4.596 ¹	4.496 ¹	5.746 ¹⁵	4.821 ²¹
Birmingham	3.75 ¹	3.80 ¹	3.80 ¹	6.153 ¹	3.675 ¹	4.05 ¹	4.05 ¹	5.20 ¹⁵	5.077 ²⁴	4.99 ²¹	5.465
New Orleans (city)	4.358 ¹	4.408 ¹	4.408 ¹	6.329 ¹	4.283 ¹	4.658 ¹	4.563 ¹	5.808 ¹⁵	5.304 ²⁴	5.073 ²¹
Houston, Tex.	4.00 ¹	4.50 ¹	4.50 ¹	5.75 ¹	3.988 ¹	4.668 ¹	4.563 ¹	5.763 ¹⁵	5.819 ¹⁶	4.10 ²¹
Los Angeles	4.65 ¹	4.90 ¹	5.20 ¹	7.45 ¹	5.225 ¹	5.30 ¹	5.200 ¹	6.55 ¹²	7.425 ²⁴	6.033 ²¹	5.863
San Francisco	4.20 ¹	4.15 ¹	4.15 ¹	5.85 ¹	4.125 ¹	5.85 ¹	4.50 ¹	6.85 ¹⁵	6.875 ¹⁵	5.783 ²¹	7.583
Portland, Oreg.	4.70 ²⁷	4.70 ²⁷	5.00 ²⁷	6.75 ²⁷	4.875 ²⁷	6.65 ²⁷	5.000 ²⁷	6.20 ¹⁵	6.825 ¹⁵	5.983 ²¹
Tacoma, Wash.	4.60 ^o	4.70 ^o	5.00 ^o	6.75 ^o	4.87 ^o	5.80 ^o	4.60 ^o	6.40 ¹⁵	6.55 ¹⁵	6.23 ²¹
Seattle	4.60 ^o	4.70 ^o	5.00 ^o	6.75 ^o	4.87 ^o	5.80 ^o	4.60 ^o	6.40 ¹⁵	6.55 ¹⁵	6.23 ²¹

^oBasing point cities with quotations representing mill prices, plus warehouse spread; †open market price.

BASE QUANTITIES

¹—400 to 1999 pounds; ²—400 to 14,999 pounds; ³—any quantity; ⁴—300 to 1999 pounds; ⁵—400 to 8999 pounds; ⁶—300 to 9999 pounds; ⁷—400 to 39,999 pounds; ⁸—under 2000 pounds; ⁹—under 4000 pounds; ¹⁰—500 to 1499 pounds; ¹¹—one bundle to 39,999 pounds; ¹²—150 to 2249 pounds; ¹³—150 to 1499 pounds; ¹⁴—three to 24 bundles; ¹⁵—450

to 1499 pounds; ¹⁶—one bundle to 1499 pounds; ¹⁷—one to nine bundles; ¹⁸—one to six bundles; ¹⁹—100 to 749 pounds; ²⁰—300 to 1999 pounds; ²¹—1500 to 39,999 pounds; ²²—1500 to 1999 pounds; ²³—1000 to 39,999 pounds; ²⁴—400 to 1499 pounds; ²⁵—1000 to 1999 pounds; ²⁶—under 25 bundles, Cold-rolled strip, 2000 to 39,999 pounds, base; ²⁷—300 to 4999 pounds.

ORES

Lake Superior Iron Ore	
Gross ton, 51½% (Natural)	
Lower Lake Ports	
Old range bessemer	\$5.45
Mesabi nonbessemer	5.05
High phosphorus	5.05
Mesabi bessemer	5.20
Old range nonbessemer	5.30
Eastern Local Ore	
Cents, units, del. E. Pa.	
Foundry and basic 56-63% contract	18.00

Indian and African	
48% 2.8:1	\$39.75
48% 3:1	41.00
48% no ratio	31.00
South African (Transvaal)	
44% no ratio	\$27.40
45% no ratio	23.30
48% no ratio	31.00
50% no ratio	32.80

Rhodesian	
45% no ratio	\$28.30
48% no ratio	31.00
48% 3:1 lump	41.00
Domestic (seller's nearest rail)	
48% 3:1	\$43.50
less \$7 freight allowance.	

Manganese Ore
Sales prices of Office of Metals Reserve, cents per gross ton unit, dry, 48%, at New York, Philadelphia, Baltimore, Norfolk, Mobile and New Orleans, 85c; Fontana, Calif., Provo,

Utah, and Pueblo, Colo., 91c; prices include duty on imported ore and are subject to established premiums, penalties and other provisions. Price at basing points which are also points of discharge of imported manganese ore is fob cars, shipside, at dock most favorable to the buyer. Outside shipments direct to consumers at 15c to 17c per unit less than Metal Reserve prices.

Molybdenum
Sulphide conc., lb., Mo. cont., mines \$0.75

NATIONAL EMERGENCY STEELS (Hot Rolled)

	Designation	Chemical Composition Limits, Per Cent						Basic open-hearth Electric furnaces			
		Carbon	Mn	Si	Cr	Ni	Mo	Bars per 100 lb.	Billets per GT	Bars per 100 lb.	Billets per GT
	NE 9415	.13-.18	.80-1.10	.20-.35	.30-.50	.30-.60	.08-.15	\$0.812	\$16.230	\$1.353	\$27.050
	NE 9425	.23-.28	.80-1.20	.20-.35	.30-.50	.30-.60	.08-.15	.812	16.230	1.353	27.050
	NE 9442	.40-.45	1.00-1.30	.20-.35	.30-.50	.30-.60	.08-.15	.866	17.312	1.407	28.132
	NE 9722	.20-.25	.50-.80	.20-.35	.10-.25	.40-.70	.15-.25	.703	14.066	1.244	24.886
	NE 9912	.10-.15	.50-.70	.20-.35	.40-.60	1.00-1.30	.20-.30	1.298	25.968	1.677	33.542
	NE 9920	.18-.23	.50-.70	.20-.35	.40-.60	1.00-1.30	.20-.30	1.298	25.968	1.677	33.542

Gross ton fob cars, New York, Philadelphia, Baltimore, Charleston, S. C., Portland, Oreg., or Tacoma, Wash.

(S S paying for discharge; dry basis, subject to penalties if guarantees are not met.)

Extras are in addition to a base price of 2.921c, per pound on finished products and \$58.43 per gross ton on semifinished steel major basing points and are in cents per pound and dollars per gross ton. No prices quoted on vanadium alloy.

MARKET PRICES

Pig Iron

Maximum prices per gross ton fixed by OPA schedule No. 10, last amended July 27, 1945; \$2 increase may be charged on adjustable pricing contracts made between May 29 and July 27. Delivered prices do not include 3 per cent federal tax, effective Dec. 1, 1942.

	No. 2 Foundry	Basic	Bessemer	Malleable
Bethlehem, Pa., base	\$29.50	\$29.00	\$30.50	\$30.00
Newark, N. J., del.	31.20	30.70	32.20	31.70
Brooklyn, N. Y., del.	32.28			32.78
Birdsboro, Pa., base	29.50	29.00	30.50	30.00
Birmingham, base	24.88	23.50	29.50	
Baltimore, del.	30.22			
Boston, del.	29.68			
Chicago, del.	28.72			
Cincinnati, del.	28.94	28.06		
Cleveland, del.	28.62	27.74		
Newark, N. J.	30.82			
Philadelphia, del.	30.05	29.55		
St. Louis, del.	28.62	29.54		
Buffalo, base	28.50	27.50	29.50	29.00
Boston, del.	30.06	29.56	31.06	30.56
Rochester, del.	30.03		31.03	30.53
Syracuse, del.	30.58		31.58	31.08
Chicago, base	29.58	28.00	29.00	28.50
Milwaukee, del.	29.73	29.23	30.23	29.73
Muskegon, Mich., del.	32.05			32.05
Cleveland, base	28.50	28.00	29.00	28.50
Akron, Canton, del.	30.04	29.54	30.54	30.04
Detroit, base	28.50	28.00	29.00	28.50
Saginaw, Mich., del.	30.81	30.31	31.31	30.81
Duluth, base	29.00	28.50	29.50	29.00
St. Paul, del.	31.13	30.63	31.63	31.13
St. Louis, base	28.50	28.00	29.00	28.50
Everett, Mass., base	29.50	29.00	30.50	30.00
Boston, del.	30.06	29.56	31.06	30.56
Granite City, Ill., base	28.50	28.00	29.00	28.50
St. Louis, del.	29.06	28.50		29.00
Hamilton, O., base	28.50	28.00		28.50
Cincinnati, del.	29.68	29.18		29.68
Neville Island, Pa., base	28.50	28.00	29.00	28.50
Pittsburgh, del. N.&S. sides	29.27	28.77	29.77	29.27
Provo, Utah, base	26.50	26.00		
Sharpville, Pa., base	28.50	28.00	29.00	28.50
Sparrows Point, base	29.50	29.00		
Baltimore, del.	30.60			
Steelton, Pa., base		29.00		
Swedeland, Pa., base	29.50	29.00	30.50	30.00
Philadelphia, del.	30.43	29.93		30.93
Toledo, O., base	28.50	28.00	29.00	28.50
Tonawanda, O., base	28.50	28.00	29.00	28.50
Mansfield, O., del.	30.66	30.16	31.16	30.66

* To Neville Island base add: 61c for McKees Rocks, Pa.; 93c Lawrenceville, Homestead, McKeesport, Ambridge, Monaca, Allquippa; 97c (water), Monongahela; \$1.24, Oakmont, Verona; \$1.38, Brackenridge.

Exceptions to above prices: Struthers Iron & Steel Co., Struthers, O., may charge 50 cents a ton in excess of basing point prices for No. 2 foundry, basic, bessemer and malleable pig iron. Republic Steel Corp. may quote \$2 a ton higher for foundry and basic pig iron on the Birmingham base.

High Silicon, Silvery

6.00-6.50 per cent (base) . . .	\$34.00
6.51-7.00 . . .	\$35.00
7.01-7.50 . . .	36.00
7.51-8.00 . . .	37.00
8.01-8.50 . . .	38.00
8.51-9.00 . . .	39.00
9.01-9.50 . . .	40.00
9.51-10.00 . . .	41.00
10.01-10.50 . . .	42.00
10.51-11.00 . . .	43.00
11.01-11.50 . . .	44.00

Fob Jackson county, O., per gross ton; Buffalo base \$1.25 higher. Buyer may use whichever base is more favorable.

Electric Furnace Ferrosilicon: Si 14.01 to 14.50%, \$50 Jackson co.; each additional 0.50% silicon up to and including 18% add \$1; low impurities not exceeding 0.005 P, 0.40 Si, 1.0% C, add \$1.

Bessemer Ferrosilicon

Prices same as for high silicon silvery iron, plus \$1 per gross ton.

Charcoal Pig Iron

Semi-cold blast, low phosphorus. Fob furnace, Lyles, Tenn., \$33.00. (For higher silicon irons a differential over and above the price of base grade is charged as well as for the hard chilling iron, Nos. 5 and 6.)

Gray Forge

Neville Island, Pa. \$28.00
Valley base 28.00

Low Phosphorus

Basing points: Birdsboro, Pa., Steelton, Pa., and Buffalo, N. Y., \$34.00 base; \$35.38, del., Philadelphia. Intermediate phosphorus, Central Furnace, Cleveland, \$31.00.

Differentials

Basing point prices are subject to following differentials:
Silicon: An additional charge not to exceed 50 cents a ton for each 0.25 per cent silicon in excess of base grade (1.75% to 2.25%).
Phosphorus: A reduction of 38 cents a ton for phosphorus content of 0.70 per cent and over.
Manganese: An additional charge not to exceed 50 cents a ton for each 0.50 per cent, or portion thereof, manganese in excess of 1%.
Nickel: An additional charge for nickel content as follows: Under 0.50%, no extra; 0.50% to 0.74%, inclusive, \$2 a ton; for each additional 0.25% nickel, \$1 a ton.

Refractories

Per 1000, fob shipping point. Net prices

Fire Clay Brick	
Super Duty	
Pa., Mo., Ky.	\$76.00
High Heat Duty	
Pa., Ill., Md., Mo., Ky.	60.40
Ala., Ga.	60.40
N. J.	65.90
Intermediate Heat Duty	
Ohio	52.95
Pa., Ill., Md., Mo., Ky.	54.80
Ala., Ga.	49.15
N. J.	57.65

Low Heat Duty

Pa., Md., Ohio	48.00
--------------------------	-------

Malleable Bung Brick

All bases	70.45
---------------------	-------

Ladle Brick

(Pa., O., W. Va., Mo.)	
Dry Press	36.45
Wire Cut	34.15

Silica Brick

Pennsylvania	60.40
Joliet, E. Chicago	69.30
Birmingham, Ala.	60.40

Magnesite

Domestic dead-burned grains, net ton, fob Chewelah, Wash.	
Bulk	22.00
Bags	28.00

Basic Brick

Net ton, fob Baltimore, Plymouth Meeting, Chester, Pa.	
Chrome brick	54.00
Chem. bonded chrome	54.00
Magnesite brick	76.00
Chem. bonded magnesite	65.00

Fluorspar

Metallurgical grade, fob shipping point in Ill., Ky., net ton, carloads, effective CaF₂ content, 70% or more, \$33; 65% to 70%, \$32; 60% to 65%, \$31; less than 60%, \$30.

Ferroalloy Prices

Spiegeleisen: 19-21% carlot per gross ton, Palmerton, Pa., \$36; Pittsburgh, \$40.50; Chicago, \$40.60.
Ferromanganese, standard: 78-82% c.i. gross ton, duty paid, \$135 fob cars, Baltimore, Philadelphia or New York, whichever is most favorable to buyer, Rockdale or Rockwood, Tenn. (where Tennessee Products Co. is producer), Birmingham, Ala. (where Sloss-Sheffield Steel & Iron Co. is producer); \$140 fob cars, Pittsburgh (where Carnegie-Illinois Steel Corp. is producer); add \$6 for packed c.i., \$10 for ton, \$13.50 for less ton; \$1.70 for each 1%, or fraction contained manganese over 82% or under 78%.
Ferromanganese, low carbon: East-ern zone: Special, 21c; regular, 20.50c; medium, 14.50c; central zone: Special, 21.30c; regular, 20.80c; medium, 14.80c; western zone: Special, 21.55c; regular, 21.05c; medium, 15.75c. Prices are per pound contained Mn, bulk carlot shipments, fob shipping point, freight allowed. Special low-carbon has content of 90% Mn, 0.10% C, and 0.06% P.
Ferromanganese Briquets: (Weight approx. 3 lb and containing exactly 2 lb Mn) per lb of briquets. Con-tract, carlots, bulk 0.0605c, packed, eastern, freight allowed; 0.063c, 0.0655c, 0.0755c and 0.078c; central; 0.066c, 0.0685c, 0.0855c and 0.088c; western; spot up 0.25c.
Ferrotungsten: Spot 10,000 lb or more, per lb contained W, \$1.90; contract, \$1.88; freight allowed as far west as St. Louis.
Ferrotitanium: 40-45%, R.R. freight allowed, per lb contained Ti; ton

lots \$1.23; less-ton lots \$1.25; east-ern. Spot up 5c per lb.
Ferrotitanium: 20-25%, 0.10 maxi-mum carbon; per lb contained Ti; ton lots \$1.35; less-ton lots \$1.40 eastern. Spot up 5c per lb.
Ferrotitanium, High-Carbon: 15-20% contract basis, per net ton, fob Niagara Falls, N. Y., freight allowed to destination east of Missis-sippi river and north of Baltimore and St. Louis, 6.8% C \$142.50; 3-5% C \$157.50.
Ferrovandium: V 35-55%, con-tract basis, per lb contained V, fob producers plant with usual freight allowances; open-hearth grade \$2.70; special grade \$2.80; highly-special grade \$2.90.
Ferromolybdenum: 55-75% per lb. contained Mo, fob. Langloeth and Washington, Pa., furnace, any quantity 95.00c.
Ferrophosphorus: 17-19%, based on 18% P content with unitage of \$3 for each 1% of P above or below the base; gross tons per carload fob sellers' works, with freight equalized with Rockdale, Tenn.; contract price \$58.50, spot \$62.25.
Ferrosilicon: Contract, lump, packed; eastern zone quotations: 90-95% c.i. 12.65c; ton lots 13.10c, smaller lots 13.50c; 80-90% c.i. 10.35c, ton lots 10.85c, smaller lots 11.35c; 75% c.i. 9.40c, ton lots 9.95c, smaller lots 10.45c; 50% c.i. 7.90c, ton lots 8.50c, smaller lots 9.10c. Prices are fob shipping point, freight allowed, per lb. of contained Si. Spot prices 0.25c higher on 80-90%, 0.30c on 75%, 0.45c on 50%. Deduct 0.85c for bulk carlots.
Ferro-Boron: (B 17.50% min., Si 1.50% max., Al 0.50% max. and C 0.50% max.) per lb of alloy con-tract ton lots \$1.20, less ton lots \$1.30, eastern, freight allowed; \$1.2075 and \$1.3075 central; \$1.229 and \$1.329, western; spot add 5c.
Ferrocolumbium: 50-60% per lb contained columbium in gross ton lots, contract basis, R. R. freight allowed, eastern zone, \$2.25; less-ton lots \$2.30. Spot prices up 10 cents.
Ferrocrome: Contract, lump, packed; high carbon, eastern zone, c.i. 15.05c, ton lots 15.55c; central zone, add 0.40c and 0.65c; western zone, add 0.5c and 1.85c; high car-bon, high nitrogen, add 5c to all high carbon ferrocrome prices. Deduct 0.55c for bulk carlots. Spot prices up 0.25c.
**Low carbon, eastern zone, bulk, c.i., max. 0.06% C 23c; 0.1% 22.50c, 0.15% 22c, 0.2% 21.50c, 0.5% 21c, 1% 20.50c, 2% 19.50c, add 1c for 2000 lb to c.i.; central zone, add 0.4c for bulk, c.i., and 0.65c for 2000 lb to c.i.; western zone, add 0.5c for bulk, c.i., and 1.85c for 2000 lb to c.i.; carload packed differential 0.45c. Prices are per pound of con-tained Cr, fob shipping points. Low carbon, high nitrogen: Add 2c to low carbon ferrocrome prices. For higher nitrogen low carbon, add 2c for each 0.25% of nitrogen over 0.75%.
Ferrocrome, Special Foundry: (Cr 62-66%, C about 5-7%): Contract, lump, packed, eastern zone, freight allowed, c.i. 15.60c, ton lots 16.10c,**

less than ton 16.75c; central zone, add 0.40c for c.i. and 0.65c for smaller lots; western zone, add 0.5c for c.i. and 1.85c for smaller lots. Deduct 0.55c for bulk carlots.
S. M. Ferrocrome, high carbon (Cr 60-65%, Si, Mn and C 4-6% each): Contract, lump, packed, eastern zone, freight allowed. c.i. 16.15c, ton lots 16.65c, less ton 17.30c; central zone, add 0.40c for c.i. and 0.65c for smaller lots; western zone, add 0.5c for c.i. and 1.85c for smaller lots. Prices are per lb of contained chromium; spot prices 0.25c higher. Deduct 0.55c for bulk carlots.
S. M. Ferrocrome, low carbon: (Cr 62-66%, Si 4-6%, Mn 4-6% and C 1.25% max.) Contract, carlot, bulk, 20.00c, packed 20.45c, ton lots 21.00c, less ton lots 22.00c, eastern, freight allowed, per pound contained chromium, 20.40c, 20.50c, 20.95c and 22.65c, central; 21.00c, 21.45c, 22.85c and 23.85c, western; spot up 0.25c.
Ferrocrome Briquets: Containing exactly 2 lb. Cr, packed, eastern zone, c.i. 9.50c, ton lots 9.80c, less than ton 10.10c, central zone, add 0.3c for c.i. and 0.5c for smaller lots; western zone, add 0.70c for c.i. and 2c for smaller lots. Deduct 0.30c for bulk carlots. Prices per lb. of briquets; spot prices 0.25c higher.
Chromium Metal: 97% min. chromi-um, max. 0.50% carbon, eastern zone, per lb contained chromium bulk, c.i., 79.50c, 2000 lb to c.i. 80c; central 81c and 82.50c; west-ern 82.25c and 84.75c; fob ship-ping point, freight allowed.

Chromium-Copper: (Cr 8-11%, Cu 88-90%, Fe 1% max., Si 0.50% max.) contract, any quantity, 45c, eastern, Niagara Falls, N. Y., basis, freight allowed to destination, except to points taking rate in excess of St. Louis rate to which equivalent of St. Louis rate will be allowed; spot up 2c.

Calcium metal; east; Contract ton lots or more \$1.35, less, \$1.60, pound of metal; \$1.36 and \$1.61 central, \$1.40 and \$1.65, western; spot up 5c.

Calcium-Manganese-Silicon: (Ca 16-20%, Mn 14-18% and Si 53-59%), per lb. of alloy. Contract, carlots, 15.50c, ton lots 16.50c and less 17.00c, eastern, freight allowed; 16.00c, 17.35c, and 17.85c, central; 18.05c, 19.10c and 19.60c western; spot up 0.25c.

Calcium - Silicon: (Ca 30-35%, Si 60-65% and Fe 3.00% max.), per lb. of alloy. Contract, carlots, lump 13.00c, ton lots 14.50c, less 15.50c eastern, freight allowed; 13.50c, 15.25c and 16.25c, central; 15.55c, 17.40c and 18.40c, western; spot up 0.25c.

Silicon Metal: Min. 97% Si and max. 1% Fe, eastern zone, bulk, c.l., 12.90c; 2000 lb to c.l., 13.45c; central, 13.20c and 13.90c; western, 13.85c and 16.80c; min. 96% Si and max. 2% Fe, eastern, bulk; c.l., 12.50c, 2000 lb to c.l., 13.10c; central, 12.80c and 13.55c; western, 13.45c and 16.50c, fob shipping point, freight allowed. Price per lb contained Si.

Silicomanganese, containing exactly 2 lb. Mn and about 1/2 lb. Si, eastern zone, bulk, c.l. 5.80c, ton lots 6.35c;

central zone, add 0.25c for c.l. and 1c for ton lots; western, add 0.55c for c.l. and 0.20c for ton lots. **Ferrosilicon,** weighing about 5 lb. and containing exactly 2 lb. Si, or about 2 1/2 lb. and containing exactly 1 lb. Si, packed, eastern zone, c.l. 3.90c, ton lots 4.15c, less ton lots 4.45c; central zone, add 0.15c for c.l. and 0.40c for smaller lots; western zone, add 0.30c for c.l. and 0.45c for smaller lots. Prices are fob shipping point, freight allowed; spot prices 0.25c higher. Deduct 0.30c for bulk carlots.

Manganese Metal: (Mn. 96% Mn, max. 2% Fe), per lb of metal, eastern zone, bulk, c.l., 30c, 2000 lb to c.l., 32c, central, 30.25c, and 33c; western, 30.55c and 35.05c.

Electrolytic Manganese: 99.9% plus, fob Knoxville, Tenn., freight allowed east of Mississippi on 250 lb or more; Carlots 32c, ton lots 34c, drum lots 36c, less than drum lot 35c. Add 1/4c for hydrogen-removed metal.

Manganese-Boron: (Mn 75% approx., B 15-20%, Fe 5% max., Si 1.50% max. and C 3% max.) per lb of alloy. Contract ton lots, \$1.89, less \$2.01, eastern; freight allowed; \$1.903 and \$2.023, central, \$1.935 and \$2.055 western; spot up 5c.

Nickel-Boron: (B 15-18%, Al 1% max., Si 1.50% max., C 0.50% max., Fe 3% max., Ni, balance), per lb of alloy. Contract, 5 tons or more, \$1.90, 1 ton to 8 ton, \$2.00, less than ton \$2.10, eastern, freight allowed; \$1.9125, \$2.0125 and \$2.1125, central; \$1.9445, \$2.0445 and \$2.1445, western; spot same as contract.

Borasil: 3 to 4% B, 40 to 45% Si, \$6.25 lb contained B, fob Philo, O., freight not exceeding St. Louis rate allowed.

Bortam: B 1.5-1.9%, ton lots, 45c lb; less-ton lots, 50c lb.

Carbortam: B 0.90 to 1.15% net ton to carload, 8c per lb fob Suspension Bridge, N. Y., freight allowed same as high-carbon ferrotitanium.

Silicaz Alloy: (Si 35-40%, Ca 9-11%, Al 5-7%, Zr 5-7%, Ti 9-11% and B 0.55-0.75%), per lb of alloy contract, carlots 25.00c, ton lots 26.00c, less ton lots 27.00c, eastern, freight allowed, 25.50c, 26.75c and 27.75c, central; 27.50c, 28.90c and 29.90c, western; spot up 0.25c.

Silvaz Alloy: (Si 35-40%, Va 9-11%, Al 5-7%, Zr 5-7%, Ti 9-11% and B 0.55-0.75%), per lb of alloy. Contract, carlots 58.00c, ton lots 59.00c, less 60.00c, eastern freight allowed; 58.50c, 59.75c and 60.75c, central; 60.50c, 61.90c and 62.90c, western; spot up 0.25c.

SMZ Alloy: (Si 60-55%, Mn 5-7%, Zr 5-7% and Fe approx. 20% (per lb of alloy contract carlots 11.50c, ton lots 12.00c, less 12.50c, eastern zone, freight allowed; 12.00c, 12.85c and 13.35c central zone; 14.05c, 14.60c and 15.10c, western; spot up 0.25c.

CMSZ Alloy 4: (Cr 45-49%, Mn 4-6%, Si 18-21%, Zr 1.25-1.75% and C 3.00-4.50%). Contract carlots, bulk, 11.00c and packed 11.50c; ton lots 12.00c; less 12.50c, eastern, freight allowed; 11.50c and 12.00c, 12.75c, 13.25c, central; 13.50c and 14.00c, 14.75c, 15.25c, western; spot up 0.25c.

CMSZ Alloy 5: (Cr 50-56%, Mn

4-6%, Si 13.50-16.00%, Zr 0.75-1.25%, C 3.50-5.00%) per lb of alloy. Contract, carlots, bulk, 10.75c, packed 11.25c, ton lots 11.75c, less 12.25c, eastern, freight allowed; 11.25c, 11.75c, 12.50c and 13.00c, central; 13.25c and 13.75c, 14.50c and 15.00c, western; spot up 0.25c.

Zirconium Alloy: Zr 12-15%, per lb of alloy, eastern contract, carlots, bulk, 4.60c, packed 4.80c, ton lots 4.80c, less tons 5c, carloads, bulk, per gross ton \$102.50; packed \$107.50; ton lots \$108; less-ton lots \$112.50. Spot up \$5 per ton.

Zirconium Alloy: Zr 35-40%, eastern, contract basis, carloads in bulk or package, per lb of alloy 14.00c; gross ton lots 15.00c; less-ton lots 16.00c. Spot up 1/4c.

Aluifer: (Approx. 20% Al, 40% Si, 40% Fe) contract basis fob Niagara Falls, N. Y., lump per lb 5.88c; ton lots 6.38c; less 6.88c. Spot up 1/4c. **Aluminal:** (Approx. 20% each Si, Mn, Al) Contract, freight not exceeding St. Louis rate allowed, per lb alloy; carlots 8c; ton lots 8.75c; less-ton lots 9.25c.

Tungsten Metal Powder: Spot, not less than 97%, \$2.50-\$2.60; freight allowed as far west as St. Louis.

Grainal: Vanadium Grainal No. 1 \$7.5c; No. 6, 60c; No. 79, 45c; all fob Bridgeville, Pa., usual freight allowed.

Vanadium Pentoxide, technical grade: Fused, approx. 89-92% V₂O₅ and 5.84% Na₂O; or air dried, 83-85% V₂O₅ and 5.15% Na₂O, \$1.10 per lb contained V₂O₅, fob plant, freight allowed on quantities of 25 lb and over to St. Louis.

OPEN MARKET PRICES, IRON AND STEEL SCRAP

Following prices are quotations developed by editors of STEEL in the various centers. Quotations are on gross tons.

PHILADELPHIA:

(Delivered consumer's plant)

No. 1 Heavy Melt. Steel	\$18.75
No. 2 Heavy Melt. Steel	18.75
No. 2 Bundles	18.75
No. 3 Bundles	16.75
Mixed Borings, Turnings	13.75
Machine Shop Turnings	13.75
Billet, Forge Crops	23.75
Bar Crops, Plate Scrap	21.25
Cast Steel	21.25
Punchings	21.25
Elec. Furnace Bundles	19.75
Heavy Turnings	18.25

Cast Grades

(Fob Shipping Point)

Heavy Breakable Cast	16.50
Charging Box Cast	19.00
Cupola Cast	20.00
Unstripped Motor Blocks	17.50
Malleable	22.00
Chemical Borings	16.51

NEW YORK:

(Dealers' buying prices)

No. 1 Heavy Melt. Steel	\$15.33
No. 2 Heavy Melt. Steel	15.33
No. 2 Hyd. Bundles	15.33
No. 3 Hyd. Bundles	13.33
Chemical Borings	14.33
Machine Turnings	10.33
Mixed Borings, Turnings	10.33
No. 1 Cupola	20.00
Charging Box	19.00
Heavy Breakable	16.50
Unstripped Motor Blocks	17.50
Stove Plate	19.00

BOSTON:

(Fob shipping points. Boston differential 9c higher, steelmaking grades; Providence, \$1.09 higher)

No. 1 Heavy Melt. Steel	\$14.06
No. 2 Heavy Melt. Steel	14.06
No. 1 Bundles	14.06
No. 2 Bundles	14.06
No. 1 Bushelling	14.06
Machine Shop Turnings	9.06
Mixed Borings, Turnings	9.06
Short Shovel Turnings	11.06
Chemical Borings	13.31
Low Phos. Clippings	16.56
No. 1 Cast	20.00
Clean Auto Cast	20.00
Stove Plate	19.00
Heavy Breakable Cast	16.50

BUFFALO:

(Delivered consumers' plant)

No. 1 Heavy Melt. Steel	\$19.25
No. 2 Heavy Melt. Steel	19.25
No. 1 Bundles	19.25
No. 2 Bundles	19.25

No. 1 Bushelling	19.25
Machine Turnings	14.25
Short Shovel Turnings	16.25
Mixed Borings, Turn.	14.25
Cast Iron Borings	15.25
No. 1 Cast	20.00
Low Phos.	21.75

PITTSBURGH:

(Delivered consumers' plant)

Railroad Heavy Melting	\$21.00
No. 1 Heavy Melt. Steel	20.00
No. 2 Heavy Melt. Steel	20.00
No. 1 Comp. Bundles	20.00
No. 2 Comp. Bundles	20.00
Short Shovel Turnings	17.00
Mach. Shop Turnings	15.00
Mixed Borings, Turnings	15.00
No. 1 Cupola Cast	20.00
Heavy Breakable Cast	16.50
Cast Iron Borings	16.00
Billet, Bloom Crops	25.00
Sheet Bar Crops	22.50
Plate Scrap, Punchings	22.50
Railroad Specialties	24.50
Scrap Rail	21.50
Axles	26.00
Rail 3 ft. and under	23.50
Railroad Malleable	22.00

CLEVELAND:

(Delivered consumer's plant)

No. 1 Heavy Melt. Steel	\$19.50
No. 2 Heavy Melt. Steel	19.50
No. 1 Comp. Bundles	19.50
No. 2 Comp Bundles	19.50
No. 1 Bushelling	19.50
Mach. Shop Turnings	14.50
Short Shovel Turnings	16.50
Mixed Borings, Turnings	14.50
No. 1 Cupola Cast	20.00
Heavy Breakable Cast	16.50
Cast Iron Borings	13.50-14.00
Billet, Bloom Crops	24.50
Sheet Bar Crops	22.00
Plate Scrap, Punchings	22.00
Elec. Furnace Bundles	20.50

VALLEY:

(Delivered consumer's plant)

No. 1 R.R. Heavy Melt.	\$21.00
No. 1 Heavy Melt. Steel	20.00
No. 1 Comp. Bundles	20.00
Short Shovel Turnings	17.00
Cast Iron Borings	16.00
Machine Shop Turnings	15.00
Low Phos. Plate	22.50

MANSFIELD:

(Delivered consumer's plant)

Machine Shop Turnings	\$15.00
-----------------------	---------

CINCINNATI:

(Delivered consumer's plant)

No. 1 Heavy Melt. Steel	\$19.50
-------------------------	---------

No. 2 Heavy Melt. Steel	19.50
No. 1 Comp. Bundles	19.50
No. 2 Comp. Bundles	19.50
Machine Turnings	10.50-11.00
Shoveling Turnings	12.50-13.00
Cast Iron Borings	11.50-12.00
Mixed Borings, Turnings	10.50-11.00
No. 1 Cupola Cast	20.00
Breakable Cast	16.50
Low Phosphorus	21.00-22.00
Scrap Rails	20.50-21.00
Stove Plate	18.50-19.00

DETROIT:

(Delivered consumer's plant)

Heavy Melting Steel	\$17.32
No. 1 Bushelling	17.32
Hydraulic Bundles	17.32
Flashings	17.32
Machine Turnings	12.32
Short Shovel, Turnings	14.32
Cast Iron Borings	13.32
Low Phos. Plate	19.82
No. 1 Cast	20.00
Heavy Breakable Cast	16.50

CHICAGO:

(Delivered consumer's plant; cast grades fob shipping point; railroad grades fob tracks)

No. 1 R.R. Heavy Melt.	\$19.75
No. 1 Heavy Melt. Steel	18.75
No. 2 Heavy Melt. Steel	18.75
No. 1 Ind. Bundles	18.75
No. 2 Dir. Bundles	18.75
Baled Mach. Shop Turn.	18.75
No. 3 Galv. Bundles	16.75
Machine Turnings	13.75
Mix. Borings, Sht. Turn.	13.75
Short Shovel Turnings	15.75
Cast Iron Borings	14.75
Scrap Rails	20.25
Cut Rails, 3 feet	22.25
Cut Rails, 18-inch	23.50
Rerolling Rails	22.25
Angles, Splice Bars	22.25
Plate Scrap, Punchings	21.25
Railroad Specialties	22.75
No. 1 Cast	20.00
R.R. Malleable	22.00

ST. LOUIS:

(Delivered consumer's plant; cast grades fob shipping point)

Heavy Melting	\$17.50
No. 1 Locomotive Tires	21.00
Misc. Rails	19.00
Railroad Springs	22.00
Bundled Sheets	17.50
Axle Turnings	17.00
Machine Turnings	10.50
Shoveling Turnings	12.50
Rerolling Rails	21.00

Street Car Axles	24.50
Steel Rails, 3 ft.	21.50
Steel Angle Bars	21.00
Cast Iron Wheel's	20.00
No. 1 Cupola Cast	20.00
Charging Box Cast	22.00
Railroad Malleable	16.50
Breakable Cast	19.00
Stove Plate	15.25
Grate Bars	19.00
Brake Shoes	15.25

BIRMINGHAM:

(Delivered consumer's plant)

Billet Forge Crops	\$22.50
Structural, Plate Scrap	19.00
Scrap Rails Random	18.50
Perolling Rails	20.50
Angle Splice Bars	20.50
Solid Steel Axles	24.00
Cupola Cast	20.00
Stove Plate	19.00
Long Turnings	11.00
Cast Iron Borings	13.00
Iron Car Wheels	20.00

LOS ANGELES:

(Delivered consumer's plant)

No. 1 Heavy Melt. Steel	\$14.00
No. 2 Heavy Melt. Steel	13.00
No. 1, 2 Dir. Bundles	12.00
Machine Turnings	5.50
Mixed Borings, Turnings	3.50
No. 1 Cast	20.00

SAN FRANCISCO:

(Delivered consumer's plant)

No. 1 Heavy Melt. Steel	\$17.00
No. 2 Heavy Melt. Steel	17.00
No. 1 Bushelling	17.00
No. 1, No. 2 Bundles	9.00
No. 3 Bundles	7.00
Machine Turnings	15.50
Billet, Forge Crops	15.50
Bar Crops, Plate	15.50
Cast Steel	15.50
Cut, Structural, Plate	18.00
1 ft and under	7.00
Alloy-free Turnings	14.50
Tin Can Bundles	21.50
No. 2 Steel Wheels	24.00
Iron, Steel Axles	20.50
No. 2 Cast Steel	18.00
Uncut Frogs, Switches	18.50
Scrap Rails	15.50
Locomotive Tires	20.50

SEATTLE:

(Delivered consumer's plant)

No. 1 Heavy Melt. Steel	\$14.50
No. 2 Heavy Melt. Steel	14.50
Heavy Railroad Scrap	15.50
(Fob shipping point)	20.00
No. 1 Cupola Cast	20.00

NONFERROUS METAL PRICES

Copper: Electrolytic or Lake from producers in carlots 14.37½c, del. Conn.; less carlots 14.50c, refinery. Dealers may add ¼c for 5000 lb to carload; 1c, 1000-4999 lb; 1½c, 500-999 lb; 2c, 4-99 lb. Casting, 14.12½c, refinery, 20,000 lb or more; 14.37½c, less than 20,000 lb.

Brass Ingot: 85-5-5-5 (No. 115) 15.25c; 88-10-2 (No. 215) 18.50c; 80-10-10 (No. 305) 18.00c; No. 1 yellow (No. 405) 12.25c; carlot prices, including 25c per 100 lb freight allowance; add ¼c for less than 20 tons.

Zinc: Prime western 8.25c, select 8.35c, brass special 8.50c, intermediate 8.75c, high grade 9.25c, E. St. Louis, for carlots. For 20,000 lb to carlots add 0.15c; 10,000-20,000 lb 0.25c; 2000-10,000 lb 0.40c; under 2000 lb 0.50c.

Lead: Common 8.10c, chemical 8.20c, corroding 8.20c, E. St. Louis for carlots; add 5 points for Chicago, Minneapolis-St. Paul, Milwaukee-Kenosha districts; add 15 points for Cleveland-Akron-Detroit area, New Jersey, New York state, Texas, Pacific Coast, Richmond, Indianapolis-Kokomo; add 20 points for Birmingham, Connecticut, Boston-Worcester, Springfield, New Hampshire, Rhode Island.

Primary Aluminum: 99% plus, ingots 15.00c del., pigs 14.00c del.; metallurgical 94% min. 13.50c del. Base 10,000 lb and over; add ¼c 2000-9999 lb; 1c less through 2000 lb.

Secondary Aluminum: Piston alloy (No. 122 type) 12.75c; No. 12 foundry alloy (No. 2 grade) 12.25c; steel deoxidizing grades, notch bars, granulated or shot: Grade 1 (95-97½%) 13.50c; grade 2 (92-95%) 12.50c; grade 3 (90-92%) 11.62½c; grade 4 (85-90%) 10.87½c. Above prices for 30,000 lb. or more; add ¼c 10,000-30,000 lb; ½c 5000-10,000 lb; ¾c 1000-5000 lb; 1¼c less than 1000 lb. Prices include freight at carload rate up to 75c per 100 lb.

Magnesium: Commercially pure (99.8%) standard ingots (4-notch, 17 lb) 20.50c per lb, carlots; 22.50c 100 lb to c.i. Extruded 12-in. sticks 27.50c, carlots; 29.50c 100 lb to c.i.

Tin: Prices ex-dock, New York in 5-ton lots. Add 1 cent for 2240-11,199 lb, 1¼c 1000-2239, 2¼c 500-999, 3c under 500. Grade A, 99.8% or higher (includes Straits), 52.00c; Grade B, 99.8% or higher, not meeting specifications for Grade A, with 0.05% max. arsenic, 51.87½c; Grade C, 99.65-99.79% incl. 51.62½c; Grade D, 99.50-99.64% incl., 51.50c; Grade E, 99.49-99% incl. 51.12½c; Grade F, below 99% (for tin content), 51.00c.

Antimony: American bulk carlots fob Laredo, Tex., 99.0% to 99.8% and 99.8% and over but not meeting specifications below, 14.50c; 99.8% and over (arsenic, 0.05% max.; other impurities, 0.1% max.) 15.00c. On producers' sales add ¼c for less than carload to 10,000 lb; ½c for 9999-224 lb; and 2c for 223 lb and less; on sales by dealers, distributors and jobbers add ¼c, 1c, and 3c, respectively.

Nickel: Electrolytic cathodes, 99.5%, fob refinery 35.00c lb; pig and shot produced from electrolytic cathodes 36.00c; "P" nickel shot or ingot for additions to cast iron, 34.00c.

Mercury: Open market, spot, New York, \$98-100 per 76-lb flask.

Arsenic: Prime, white, 99%, carlots, 4.00c lb.

Beryllium-Copper: 3.75-4.25% Be, \$14.75 per lb contained Be.

Cadmium: Bars, ingots, pencils, pigs, plates, rods, slabs, sticks, and all other "regular" straight or flat forms \$1.25 lb, del.; anodes, balls, discs and all other special or patented shapes, \$1.30.

Cobalt: 97-99%, \$1.50 lb, for 550 lb (bbl.); \$1.52 lb for 100 lb (case); \$1.57 lb under 100 lb.

Gold: U. S. Treasury, \$35 per ounce.

Iridium: 99.9%, \$2.25 per troy ounce.

Silver: Open market, N. Y. 90.12½c per ounce.

Platinum: \$81.50 per ounce.

Palladium: \$24 per troy ounce.

Iridium: \$125 per troy ounce.

Rolled, Drawn, Extruded Products

(Copper and brass product prices based on 14.37½c, Conn., for copper. Freight prepaid on 100 lb or more.)

Sheet: Copper 25.81c; yellow brass 23.67c; commercial bronze, 95% 26.14c, 90% 25.81c; red brass, 85% 24.98c, 80% 24.66c; best quality 24.38c; phosphor bronze, grade A 4% or 5%, 43.45c; Everdur, Duronze or equiv., hot rolled, 30.88c; naval brass 28.53c; manganese bronze 31.99c; muntz metal 26.78c; nickel silver 5% 32.38c.

Rods: Copper, hot rolled 22.16c, cold drawn 23.16c; yellow brass 18.53c; commercial bronze, 95% 25.83c, 90% 25.50c; red brass, 85% 24.67c; 80% 24.35c; best quality 24.07c; phosphor bronze, grade A 4% or 5% 43.70c; Everdur, Duronze or equiv. cold drawn, 29.82c; naval brass 22.59c; manganese bronze 25.93c; muntz metal 22.34c; nickel silver 5% 34.44c.

Seamless Tubing: Copper 25.85c; yellow brass 26.43c; commercial bronze 90% 28.22c; red brass 85% 27.64c, 80% 27.32c; best quality brass 26.79c; phosphor bronze, grade A 5% 44.70c.

Copper Wire: Bare, soft, fob eastern mills, carlots 19.89c, less carlots 20.39c; weatherproof, fob eastern mills, carlot 22.07c, less carlots 22.57c; magnet, delivered, carlots, 23.30c, 15,000 lb or more 23.55c, less carlots 24.05c.

Aluminum Sheets and Circles: 2s and 3s flat mill finish, base 30,000 lb or more del.; sheet widths as indicated; circle diameter 9" and larger:

Gage	Width	Sheets	Circles
.249"-7	12"-48"	22.70c	25.20c
8-10	12"-48"	23.20c	25.70c
11-12	26"-48"	24.20c	27.00c
13-14	26"-48"	25.20c	28.50c
15-18	26"-48"	26.40c	30.40c
17-18	26"-48"	27.90c	32.90c
19-20	24"-42"	29.80c	35.90c
21-22	24"-42"	31.70c	37.20c
23-24	3"-24"	25.60c	29.20c

Lead Products: Prices to jobbers; full sheets 11.25c; cut sheets 11.50c; pipe 9.90c, New York, 10.00c Philadelphia, Baltimore, Rochester and Buffalo, 10.50c Chicago, Cleveland, Worcester and Boston.

Zinc Products: Sheet fob mill, 13.15c, 36,000 lb. and over deduct 7%. Ribbon and strip 12.25c, 3000-lb lots deduct 1%, 6000 lb 2%, 9000 lb 3%, 18,000 lb 4%, carloads and over 7%. Boiler plate (not over 12") 3 tons and over 11.00c; 1-3 tons 12.00c; 500-2000 lb 12.50c; 100-500 lb 13.00c; under 100 lb 14.00c. Hull plate (over 12") add 1c to boiler plate prices.

PLATING MATERIALS

Chromic Acid: 99.75%, flake, del., carloads 16.25c; 5 tons and over 16.75c; 1-5 tons 17.25c; 400 lb to 1 ton 17.75c; under 400 lb 18.25c.

Copper Anodes: In 500-lb lots, fob shipping point, freight allowed, cast oval over 15 in., 25.125c; curved, 20.375c; round oval straight, 19.375c; electro-deposited, 18.875c.

Copper Carbonate: 52-54% metallic Cu, 250 lb barrels 20.50c.

Copper Cyanide: 70-71% Cu, 100-lb kegs or bbls 34.00c, fob, Niagara Falls.

Sodium Cyanide: 96%, 200-lb drums 15.00c; 10,000-lb lots 13.00c fob Niagara Falls.

Nickel Anodes: 500-2999 lb lots; cast and rolled carbonized 47.00c; rolled depolarized 48.00c.

Nickel Chloride: 100-lb kegs or 275-lb bbls 18.00c lb, del.

Tin Anodes: 1000 lb and over 58.50c del.; 500-999 59.00c; 200-499 59.50c; 100-199 61.00c.

Tin Crystals: 400 lb bbls 39.00c fob Grassell, N. J.; 100-lb kegs 39.50c.

Sodium Stannate: 100 or 300-lb drums 36.50c, del.; ton lots 35.50c.

Zinc Cyanide: 100-lb kegs or bbls 33.00c fob Niagara Falls.

Scrap Metals

Brass Mill Allowances: Prices for less than 15,000 lb fob shipping point. Add ¼c for 15,000-40,000 lb; 1c for 40,000 or more.

	Clean Heavy	Rod Ends	Clean Turnings
Copper	12.000	12.000	11.250
Yellow brass	9.875	9.625	9.125
Commercial bronze			
95%	11.250	11.000	10.500
90%	11.125	10.875	10.375
Red brass			
85%	10.875	10.625	10.125
80%	10.875	10.625	10.125
Best quality (71-79%)	10.500	10.250	9.750
Muntz metal	9.250	9.000	8.500
Nickel silver, 5%	10.500	10.250	5.250
Phos. br., A, B, 5%	12.750	12.500	11.500
Naval brass	9.500	9.250	8.750
Manganese bronze	9.500	9.250	8.750

Other than Brass Mill Scrap: Prices apply on material not meeting brass mill specifications and are fob shipping point; add ¼c for shipment of 60,000 lb of one group and ½c for 20,000 lb of second group shipped in same car. Typical prices follow:

(Group 1) No. 1 heavy copper and wire, No. 1 tinned copper, copper borings 11.50c; No. 2 copper wire and mixed heavy copper, copper tuyeres 10.50c

(Group 2) Soft red brass and borings, aluminum bronze 10.75c; copper-nickel solids and borings 11.00c; lined car boxes, cocks and faucets 9.50c; bell metal 17.25c; babblitt-lined brass bushings 14.75c.

(Group 3) Admiralty condenser tubes, brass pipe 8.75c; muntz metal condenser tubes 8.25c; old rolled brass 8.25c; manganese bronze solids (lead 0%-0.40%) 8.00c; (lead 0.41%-1%) 7.00c; manganese bronze borings, 7.25c.

Aluminum Scrap: Price fob point of shipment, truckloads of 5000 pounds or over; Segregated solids, 2S, 3S, 5c lb, 11, 14, etc., 3 to 3.50c lb. All other high grade alloys 5c lb. Segregated borings and turnings, wrought alloys, 2, 2.50c lb. Other high-grade alloys 3.50c, 4.00c lb. Mixed plant scrap, all solids, 2, 2.50c lb borings and turnings one cent less than segregated.

Lead Scrap: Prices fob point of shipment. For soft and hard lead, including cable lead, deduct 0.75c from basing point prices for refined metal.

Zinc Scrap: New clippings 7.25c, old zinc 5.75c, fob point of shipment, add ¼c for 10,000 lb or more. New die cast scrap 4.95c, radiator grilles 4.95c, add ¼c for 20,000 lb or more. Unsweated zinc dross, die cast slab 5.80c, any quantity.

Nickel, Monel Scrap: Prices fob point of shipment; add ¼c for 2000 lb or more of nickel or cupro-nickel shipped at one time and 20,000 lb or more of Monel. Converters (dealers) allowed 2c premium.

Nickel: 95% or more nickel and not over ¼% copper 23.00c; 90-98% nickel, 23.00c per lb nickel contained.

Cupro-nickel: 90% or more combined nickel and copper 26.00c per lb contained nickel, plus 8.00c per lb contained copper; less than 90% combined nickel and copper 26.00c per lb contained nickel only.

Monel: No. 1 castings, turnings 15.00c; new clipping 20.00c; soldered sheet 18.00c.

Sheets, Strip . . .

High production gives little relief to heavy demand; CPA preference rating to cause re-scheduling

Sheet & Strip Prices, Page 168

Pittsburgh — Production outlook is brighter than at any time this year but no significant relief from the present shortage is indicated until late fourth quarter at the earliest. Huge pent-up demand for flat-rolled steel items is expected to more than absorb record breaking production well into next year, but there is some indication that present heavy demand will be dissipated early next year as result of prospective improvement in overall supply, due to completion of expansion programs now under way. By July 1, 1947, sheet and strip capacity is expected to top prewar volume by 2.5 million tons.

Under CPA's fourth quarter preference rating program, to meet essential steel requirements for farm equipment, brakeshoes and housing, there may be one notable variance from the present certified tonnage procedure. Producers are not expected to have to honor CC ratings of those companies not regular customers.

RFC has made arrangements to purchase 180,000 tons of sheet bars from Sharon Steel Corp. for redistribution to Mahoning Valley Steel Co., Niles, O., Reeves Steel & Mfg. Co., Dover, O.; Superior Steel Co., Canton, O., and Apollo Steel Co., Apollo, Pa. The agency has agreed to pay Sharon a premium of \$7 a ton, plus freight differential. Jones & Laughlin Steel Corp. also will supply these companies 25,000 tons of sheet bars in August, September, October and November, at \$45.84 a ton to RFC plus freight. Selling price to the nonintegrated interests will be \$38 a ton.

Chicago — Announcement by CPA that the preference system will be reimposed has raised the question among steel producers and consumers as to how effective it will be. To consumers with short supplies, it brings new hopes; to producers it implies much rescheduling and confusion. Product most affected under the system is steel sheets, which are in desperate shortage despite near maximum production. Demand for all grades is tremendous and deliveries are far behind as result of the steel and coal strikes, indicating heavy carryovers into fourth quarter and next year. Electrical sheets are extremely critical. Without exception, sheetmakers decline to book 1947 business although pressure to do so has been substantial and persistent. One district mill states that orders for galvanized sheets covered by directives and the 2 per cent earmarked for export exhaust its entire output, leaving none for normal customers.

New York — Sheet sellers are keenly waiting developments in Washington with respect to applications submitted by consumers prior to Aug. 16 for ratings effective Oct. 1, especially the CC ratings which apply to civilian work. In effect these ratings will likely provide for most, if not all of the preference tonnage rolled in fourth quarter, particularly with Direction 12 due to expire

Sept. 30. Considering the likely carry-over of preference business from the current quarter, many sellers look for an increasing amount of priority work in the closing period and are anxious to get a line on prospective requirements as soon as possible; hence their interest in Washington's response to applications for ratings.

Some producers estimate they will lose about 10 per cent of their third quarter preference tonnage; they fear they will lose at least that much if not more in fourth quarter for the same reason. Due to these losses, among other factors, producers are still having difficulty making headway on arrearages, which resulted particularly from the steel and coal strikes in first half. They are making some gains, however. Their greatest trouble is in improving their positions on coated sheets, especially galvanized. Some sellers are still two to three months behind.

Cleveland — Additional producers of flat-rolled products have canvassed customers to determine first quarter requirements. In most instances, producers will inform customers what tonnage they can reasonably expect for that period, taking into consideration an estimate of certified order requirements, probable production and similar factors. Some producers are canceling a large portion of orders they will be unable to fill this year in an effort to reduce tonnage carried over into 1947. The order backlog is being reduced also by the fact that shipments are now exceeding production in many instances, although some mills are having difficulty in attaining the prestrike rate of operations. Only a few certified orders were recorded in this district for September delivery and some producers required customers to take a proportionate reduction in uncertified orders, leaving the actual tonnage on books unchanged. Due to filled mill schedules, customers are unable to revise specifications or substitute one order for another unless the material can be rolled in the same mill. Some emergency needs are being filled, however, from overruns and limited mill stocks.

Boston — More steel to the manufacturing consumer in fourth quarter appears in the cards unless the warehouse certification directive is extended. Jobbers will get less. Several producers have extended themselves to meet warehouse directives, but at expense of manufacturing requirements to some degree and prospective programs aim at making up some of this ground once allotted volume to warehouses is filled this quarter. Mill shipments are heavier, but in the case of distributors inventory has not improved in proportion; high ratio of improved receipts has been shipped out without going into stock. There are few signs of any easing in sheets, although given high production over the next few weeks, this might well develop in backlog orders. There is heavy unplaced flat-rolled tonnage openings for a place in schedules once openings appear.

Cincinnati — Fourth quarter schedules of sheet mills may show cut in allocation of cold-rolled, in contrast to quotas earlier in the year. Need for electrical sheets, directives and other factors are cited. The pinch in hot-rolled may not be so severe. Operations of the Newport Rolling Mill Co. are near ca-

capacity after a two-day shutdown for inventory, incident to sale of all fixed assets of the company and subsidiaries to International Detrola Corp., Detroit. Output will be available to other fabricators, as heretofore.

St. Louis — Limited production of cold-rolled sheets and plates got under way here last week with the 21-week strike at the Granite City Steel Co. at an end. All flat steel schedules are filled to the year's end with substantial 1947 carryover. OPA has asked the company to give priority to car builders, which closes the few gaps left by order cancellations. No new orders will be considered until operations are worked out and backlogs reviewed.

Birmingham — Sheet production, while steady at near capacity, finds the product in somewhat uneven distribution with local users generally on the short end. Light sheets and roofing are in especially heavy demand and backlogs are high, even though they have been worked off to a moderate extent.

Steel Bars . . .

Mills sold for year in most sizes and grades, with production at high rate; alloys are easy

Bar Prices, Page 168

Pittsburgh — Cold finishers have some openings for larger sizes for fourth quarter, and a little headway currently is being made against carryover tonnage now that shipments have been resumed on a normal basis. Automotive parts manufacturers and most forge shops have been able to increase production slightly in recent weeks, although most do not expect any significant increase in steel supply through rest of this year. Delivery pressure for small carbon bars continues to increase and no openings likely will develop this year. Some district offices are taking on small orders to balance out tonnage allotted them for the balance of this year; however, in most instances all the projected tonnage allotted these offices is more than represented by orders on hand. Shipments on alloy bars are available for late September and October. Sellers do not know to what extent CC ratings will disrupt fourth quarter production schedules, although some predict the monthly tonnage involved will exceed scheduled September shipments of certified tonnage.

Chicago — Hot and cold-rolled carbon bars are in good demand and consumers are pressing for deliveries. Comparatively few major strikes in manufacturing plants are under way currently and fabricating operations have risen to a higher level. Some barmakers report that so far they have not received orders against CPA's 2 per cent set aside for export, consequently it has not been necessary to divert tonnage from regular customers. Restoration of the preference rating system Oct. 1 undoubtedly will cause a good deal of rescheduling of orders for fourth quarter, but it is too early to make any appraisal of this. Since year-end carryover cannot be estimated, mills are de-

clining to accept business for 1947.

New York — Demand for small carbon bars and flats is said to be stronger than at any time during the war. Meanwhile, sellers still are far behind on their current commitments, are seeking the co-operation of customers in a review of tonnage on mill books. Many orders have been placed long ago and an effort is being made to see if some of the tonnage can be dropped from schedules, or at least be set aside for rescheduling at some future date. Most consumers so far, however, have been unwilling to relinquish their present positions, even though deliveries may be further deferred for some time. Producers look for more preference tonnage in fourth quarter than at present, and while operating rates this period and next should be much higher than during the first two quarters they expect a heavy carryover into next year. Certain producers believe, in view of present commitments and the further priority tonnage they will be confronted with, they will have arrearages of three to four months at the end of the year.

Boston — Carbon bar consumers are sounding suppliers on 1947 tonnage prospects and while quotas are uncertain because of expected carryovers, some stand to receive less tonnage, those who placed these duplicate orders late last year on which delivery is coming through. These duplicate orders will be impossible this year. Here and there some mild dents are being made on backlogs, but only in a few larger sizes of cold-drawn are delivery promises made for delivery this year and these have extended to November-December. Bessemer grades are extremely tight with most producers and some quotas are reduced for this month. Over 13/16th inch September delivery is still possible on hot-rolled alloys; October 13/16th and under while in cold-drawn alloys, including turned and polished, schedules are filled for the year on most sizes, with December open on few. Stainless bars are available from stocks. There is little switching of specifications in view of the better delivery for alloys, although most consumers in this area use both, but carbon substantially better than five to one. Among the bar consuming industries, textile mill equipment builders are generally well off as to steel, but are cramped for pig iron and some components. Machine tool shops are light buyers.

St. Louis — Production of merchant bars has leveled off at what is regarded as peacetime capacity, approximately 90 per cent of wartime output. Demand is mounting but no new orders are being accepted, with the exception of limited tonnage for specific essential projects and then with the reservation that shipment is to be at mill convenience. Shipments had been picking up until ODT's new order on capacity carloading. This has complicated deliveries here since bar mills with varied products find it hard to make combination shipments. Difficulty of getting old rails threatens to stop production of reinforcing bars.

Seattle — Mills are booked to the end of the year and are turning down much inquiry. Potential business is sufficient to fill capacity for a year but no 1947 orders are being booked now. Regular customers are given first call but it is difficult to fill their needs. Labor



Clean Castings

save money...

STRONG TAKES the same well earned pride in its cleaning operations that it has for its annealing facilities. In addition to the cutting, grinding and chipping processes, Strong operates three sandblasts with the larger one capable of handling any casting which comes from its 15 by 19 foot annealing furnace.

All of which adds up to a standard of castings which are much easier to machine—because the steel making, the molding, the annealing and the cleaning are all handled by Strong quality controls that safeguard the buyer's interest at all stages of the work. The surest way to have stronger castings is to have them Strong-cast!

STRONG IN NAME
STRONG IN FACT

STRONG STEEL FOUNDRY COMPANY, BUFFALO, N.Y.



TENSILE STRENGTH • ELONGATION

turnover is a problem, skilled workers being scarce.

Tin Plate . . .

Tin Plate Prices, Page 169

Pittsburgh — Direction 9 to M-21, channeling 85 per cent of tin plate production into containers for perishable foods, pharmaceuticals and related items, is expected to be revoked or at least revised for fourth quarter. Tin plate demand and supply conditions, which necessitated issuance of the direction in February, will not continue through fourth quarter. Seasonal food can requirements will be diminishing

after September, and it is also pointed out that many can plants important to food production have undergone severe hardships in attempting to maintain output on their slim share of the 15 per cent of tin mill products available for general distribution. Extent of the revision in Direction 9 will be largely dependent on size of export load directive for fourth quarter, indicated at about 135,000 tons, compared with 112,000 tons this quarter. Definite decision in both matters is expected momentarily.

Consideration also was given at the recent industry advisory committee meeting to the prospect of relaxing some conservation measures embodied in Or-

der M-43, but no revision in this order is indicated through the remainder of this year, due to continued tight pig tin supply.

Can manufacturing capacity is expected to be increased 20 per cent within the next five years to meet growing demand for metal contract. This expansion program will boost output of cans to about 20.5 billion units a year, in contrast with 17 billion prior to the war, with tin plate consumption approaching 3.6 million tons annually.

Cleveland—Order M-81 will be revised soon, according to reliable trade reports, to permit use of cans made of tin plate and terne plate for packing some presently prohibited products. The market still remains extremely tight, however, with a heavy carryover into fourth quarter, amounting to about 80,000 tons for food cans and the foreign relief program in the certified order classification and an additional tonnage in the uncertified classification. Fourth quarter export allocations have been increased 24,000 tons to 136,000. Production will be maintained at about the same rate in fourth quarter but domestic demand is expected to ease.

The large order backlog is attributed to the fact that packers grossly underestimated requirements. While the food pack was heavy in all products, it was as much as 100 per cent greater than expected in several products, including apricots, requiring use of cans that had been intended for other products.

Chicago — Tin plate production is holding up well, but shipments are delayed because of the box car shortage. Occasionally car supply improves to the point where accumulated tonnage can be moved out, but almost overnight new shortage requires piling to start all over. This situation is expected to obtain over most of the rest of the year.

Steel Plates . . .

Demand heavy in spite of shipbuilding decline and deliveries are slow; light gages for tanks lead

Plate Prices, Page 169

Boston—Compared with most heavier steel products, production of plates is below expectations, with demand maintained at high levels, notably high considering the slump in shipbuilding. Requirements cover a broad range but are heaviest in light-gage welding stock for underground tanks; in heavier sizes weldments account for a substantial tonnage. Weldment volume is benefited by shortages in gray iron castings. Several producers are losing production through lack of steelmaking materials, while another is rolling heavy sheets on a plate mill. In addition to need for more plates, tank fabricators are confronted by extended deliveries in heads, six to seven months. Plate mill backlogs extend into second quarter and selectivity in order acceptance is intensified. At least two fabricators have appealed to Washington for assistance in getting steel, one including No. 12 gage hot-rolled sheets for 275-gallon

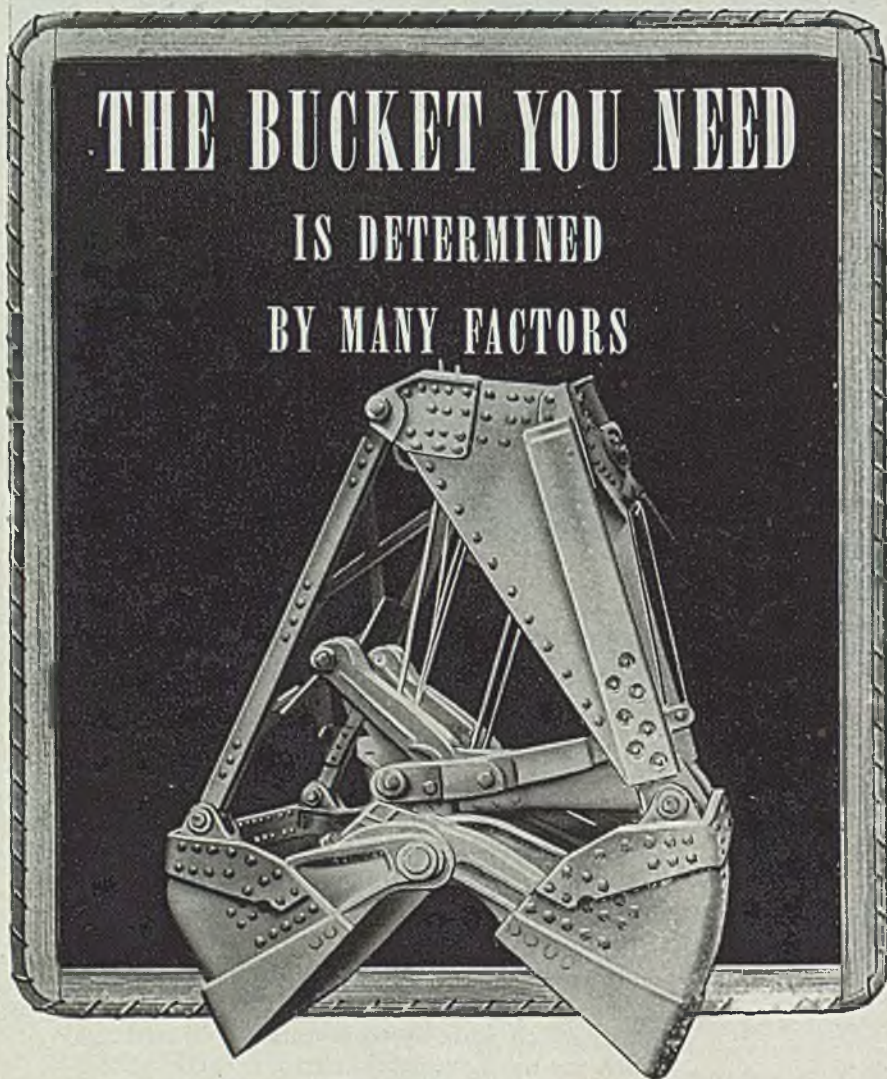

That is why Blaw-Knox maintains a list of over 100 different types and sizes.

Blaw-Knox Catalog 2002 contains sufficient information for you practically to "order by mail" exactly the clamshell you need for a particular bucket use.

Send for a copy of this informative catalog.

BLAW-KNOX DIVISION of BLAW-KNOX COMPANY
2002 FARMERS BANK BUILDING, PITTSBURGH 22, PA.

BLAW-KNOX BUCKETS

tanks as well as plates.

Philadelphia — Most plate producers are being called on to supply little preference tonnage this quarter, some being asked for none. However, export allocations for September will cause some dent, with one eastern plate mill reported to have been called on to supply 3000 tons for Norway. District plate operations continue restricted as a result of scarcity of scrap and pig iron and indications are for a further decline before improving.

New York — Most plate producers, some already covered for first quarter and beyond, as far as they can estimate at this time, are accepting little or no new business. All sellers count on a heavy carry-over into next year, and some, in addition, have until recently been accepting a fair tonnage of new business for 1947, with a result that their commitments now run so far ahead that they regard it advisable to move slowly. In fact, their immediate interest is in trying to make headway against arrearages and to sustain production, a matter some are finding it impossible to do, because of shortage of scrap and pig iron.

Seattle — Plate demand continues strong, shops having low inventories and mill shipments are low. Tank work is active. Ganderson Bros., Portland, Oreg., are low to United States engineer at \$76,300 for 70 steel pontoons. Portland, Oreg., will receive bids Sept. 4 for a 4 million-gallon steel tank.

Birmingham — Plate production is holding at capacity, as it has been since about two weeks after the coal strike, but demand pretty well keeps pace. That, with the largest backlogs in the history of the district, holds the picture on something of a hand-to-mouth basis.

Wire . . .

Wire Prices, Page 169

Pittsburgh — Critical shortage of wire rods continues to restrict output of non-integrated wire producers, although supply has improved somewhat recently for interests in the New England area. Under present price relationship integrated mills are converting as much as possible of their wire rod output into specialties and other finished items. Demand for manufacturers and merchant wire remains well above present production, with producers' schedules filled through remainder of this year. One interest recently has returned customers' orders that it had been holding on the basis of possibly meshing them into fourth quarter schedules. Among the manufacturers' wire items a very heavy demand is noted for spring wire, refrigerator racks and electric fan guards.

There has been a moderate increase in nail output recently, leading some interests to believe that CPA program for this item might be met. Premium prices have been granted some interests to stimulate nail output and it is possible that other companies may resume nail production if a satisfactory price arrangement can be obtained.

Effective Aug. 8, Pittsburgh Steel Co. was granted a premium of 35 cents per 100 pounds on bright cement coated nails and blued and polished nails



We can ship immediately...

New 6" and 4" Electric Weld Steel Tubing and Couplings

11,000,000 ft. 6" O.D., .109 Wall Thickness
 3,000,000 ft. 4" O.D., .083 Wall Thickness
 All 20 ft. lengths exact

Application of Coupling

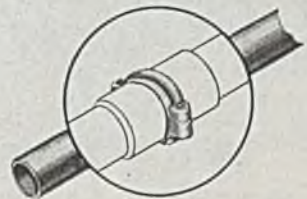

This tubing is new, excellent and has been hydrostatically tested to 900 pound pressure p.s.i. Every 20 foot length of tubing has welded on each end a 6" (6 1/2" O.D.) or 4" (4 1/2" O.D.) pipe nipple which is grooved for use with Victaulic type coupling.

This tubing is recommended for normal use and application on steam, oil, gas and water lines, for columns and other structural purposes.

Prompt shipments can be made from various locations throughout Ohio, Pennsylvania, New York, New Jersey, Illinois, Missouri and Virginia.

Prices will be submitted upon application, and special arrangements are available to jobbers.

Representative samples of both sizes of couplings and tubing may be inspected at our various warehouses.

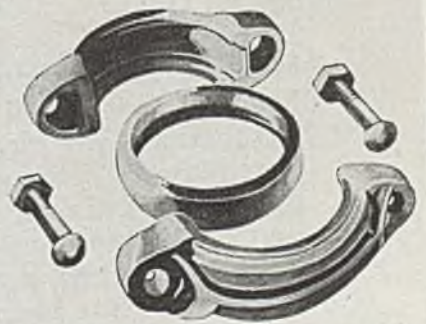

Coupling Detail

Albert Pipe Supply Company
 Berry & North 13th Street
 Brooklyn 11, New York
 Phone Evergreen 7-8100

L. B. Foster Company
 P.O. Box 1647
 Pittsburgh 30, Pa.
 Walnut 3300

Albert & Davidson Pipe Corp.
 2nd Avenue—50th, 51st Street
 Brooklyn 32, New York
 Phone Windsor 9-6300

and staples, making their OPA ceiling price \$4.10; no increase was granted on galvanized nails. The same company was given a premium price equivalent to about 44 cents a spool on barbed and barbless wire, raising their column quotations 10 points to 89. A premium price of \$10 a ton on nails was granted Nichols Wire & Steel Co., Davenport, Iowa, early in June.

Boston — Production being stressed on high carbon specialties without much progress in denting backlogs, consumers using low carbon wires, on which output is lower, are curtailed by lack of stock. Most tonnage is relatively longer processed wire and mill backlogs are unbalanced, heavy on some products but

light in others. The latter category includes the so-called cheaper stock and reflects selectivity in acceptance of orders for low-margin items. Crux of confusion in wire is limited rod supply; inventories with nonintegrated mills and industrial consumers drawing their own wire are generally well depleted and out of balance.

New York — Lack of wire is contributing to more extended deliveries on numerous products fabricated from wire, including screws and smaller fastenings, some types of mechanical springs, steel bolts, machine screws, carriage and lag bolts, ½ x 6-inch and smaller and shorter; deliveries on the latter group of fastenings have become indefinite with

more producers. Demand for wire is far in excess of supply in grades wanted by most users; backlogs in spring wire are heavy and consumers are pressing for cushion and upholstery spring stock. Production of nails is disappointing; a leading distributor here got only one car last month. Black market at retail is rampant in nails; up to \$25 a keg is reported to have been paid and higher in some districts. Pittsburgh Steel Co. has been given a \$7 advance on bright wire nails exclusive of galvanized and \$10 a ton on barbed wire.

Birmingham — No appreciable improvement in the wire situation is noted. Manufacturers are crying for drawn wire for bed springs and miscellaneous use. Serious also is the situation in nails and jobbers report practically no chance to meet demands for wire fencing with the agricultural season at its height.



BEARITE

is NOT just another

WARTIME MEASURE

Meeting the requirements of a low tin base babbitt metal was no problem for us because we already had "BEARITE" (less than 1½% tin) that had been proven by 20 years of general use. Wide adoption of this product for countless purposes in war use has proven this to be true. "BEARITE" has been weighed in the balance of wartime necessity and found NOT wanting.

A. W. Cadman Mfg. Co.

PITTSBURGH, PA.

CHICAGO: MANHATTAN BLDG. PHILADELPHIA: 18 W. CHELTON ST. NEW YORK: 270 BROADWAY

Structural Shapes . . .

Numerous large tonnages being placed for industrial projects with mills increasing output

Structural Shape Prices, Page 169

New York — Several sizable structural awards are reported here, including 16,000 tons for a plant at Rock Hill, N. C., for the Celanese Corp., placed with the Bethlehem Steel Co., Bethlehem, Pa. Other work includes 2500 tons for a gum refining plant at Oak Tree, N. J., placed with Harris Structural Steel Co., New York. A bridge project, involving 4500 tons, for New York state is expected up for estimating within the next two weeks or so. Meanwhile, several fair to good-sized jobs are active, with some really large developments in the background for some time later on, including the Graphic Arts Center on the west side of Manhattan, involving an estimated 50,000 tons. A section of the west side elevated highway, on which P. T. Cox Construction Co. Inc. is low on the general contract, as noted in a recent issue, is the largest active project here at the moment. It will require 4500 tons of structurals and additional quantities of piling and reinforcing.

Philadelphia — While structural work is restricted by CPA regulations more is still being offered than fabricators can or will accept. Some shops are booked six to eight months and none as far as can be learned, have capacity left for this year on basis of prospects of obtaining mill deliveries. A substantial amount of public work, especially state bridges, continues to come out, some for the third and fourth time. Two Pennsylvania state bridges are being figured for the fourth time, one in Northumberland county, involving 408 tons, up for bids Sept. 13; the other in Montgomery county 180 tons, bids Sept. 6. Insufficient appropriations are a major factor in many such cases.

Boston — Contracts for construction steel are up slightly and include 700 tons for a foundry for Farrel-Birmingham Co., Ansonia, Conn.; Stone & Webster Engineering Co. has placed 7500 tons of bearing piles for a General Electric Co. building at Schenectady, N. Y. Fabricat-

ing shops and structural mills are booked into second quarter next year, exceptions being small-tonnage projects when warehouses are in position to furnish plain material. Substantial volume of shapes fabricated by district shops comes from distributors. Among 35 authorizations, valued at \$1,045,267, granted week ending Aug. 10, is a bus garage for Boston Elevated Railway, Medford, Mass., \$420,000. Bids taken last month on the Saco river bridge, Fryeburg, Me., were rejected. For furnishing only, American Bridge Co., Pittsburgh, bid \$157,648 and \$34,302.60 respectively on steel for two Connecticut state highway bridges, Hamden, approximately 1200 tons.

Seattle — Fabricating shops are busy but are unable to take much business because of lack of material. Mill shipments are far below requirements. The major pending project is the Narrows bridge, requiring 17,000 tons, bids to be called soon. Plans for a proposed Oregon state bridge near Independence have been approved for 1947 construction, two steel truss spans 146 and 250 feet long, overall length 2018 feet. Cost is estimated at \$640,000.

Pig Iron . . .

Preference regulations on iron limit supply to other users; melters have little inventory, with demand high

Pig Iron Prices, Page 171

Pittsburgh — Means of increasing pig iron production and achieving a more equal distribution of iron will be discussed by the industry advisory committee in Washington early this week. Chief points likely will involve possibility of bringing idle high-cost furnaces back into operation under a subsidy arrangement, and re-establishment of pig iron distribution on an allocation basis covering 60-day periods. With reinstatement Oct. 1 of CC ratings to provide essential steel requirements for agricultural equipment, railroad brake shoes and housing, it would appear logical the present pig iron certification program or a more elaborate allocation program will have to be put in effect for fourth quarter.

Drying up of scrap supplies and earmarking of pig iron for a few favored industries have resulted in severe curtailment of many foundries not coming within the scope of the CPA's directive program. Certified tonnage shipments, as originally set up with the merchant blast furnace here, constituted nearly 50 per cent of its August and September output, which tonnage was to be shipped to only 10 per cent of its customers. However, the unbalanced distribution pattern through remainder of this quarter will be eased somewhat as result of recent CPA action reducing certified tonnage shipments 10 per cent for the period.

Chicago — There is no easing of pig iron supply and foundries are obliged to limit operations to tonnage allocated to them. It is estimated that gray iron and malleable shops are running at about 75 per cent of capacity. Some man-

power shortage exists, but is not as critical as the materials situation. It is too early to determine what will be the effect of reimposition of the preference rating system Oct. 1. Of the district's 41 blast furnaces, 37 remain in blast, however, most output necessarily goes as hot metal to steel production to offset scrap shortage.

New York — While more pig iron is being produced, jobbing foundries and others not engaged in preference work are having increasingly rough going. Many are operating part time, with some not operating at all. Urgent appeals to Washington for relief have brought little or no response so far, although some stovemakers feel they have a strong

case because of the application of their products to housing. For those who have no preference work, which would permit them a larger share of the iron, their position has been made especially acute by the shortage of cast scrap. This latter material is in shorter supply than at any time in the history of the trade, it is said.

Boston—Slight reductions in purchase orders for certified tonnage will mean little additional iron for New England consumers through the balance of this quarter. Impact of this tonnage has disrupted delivery schedules, although production is slightly heavier. Foundries not qualifying for certified iron are worse off, but a few who do, will get

Photos show typical gears ranging in size from 48 pitch to 6/8 pitch; and a section of the gear generating department.

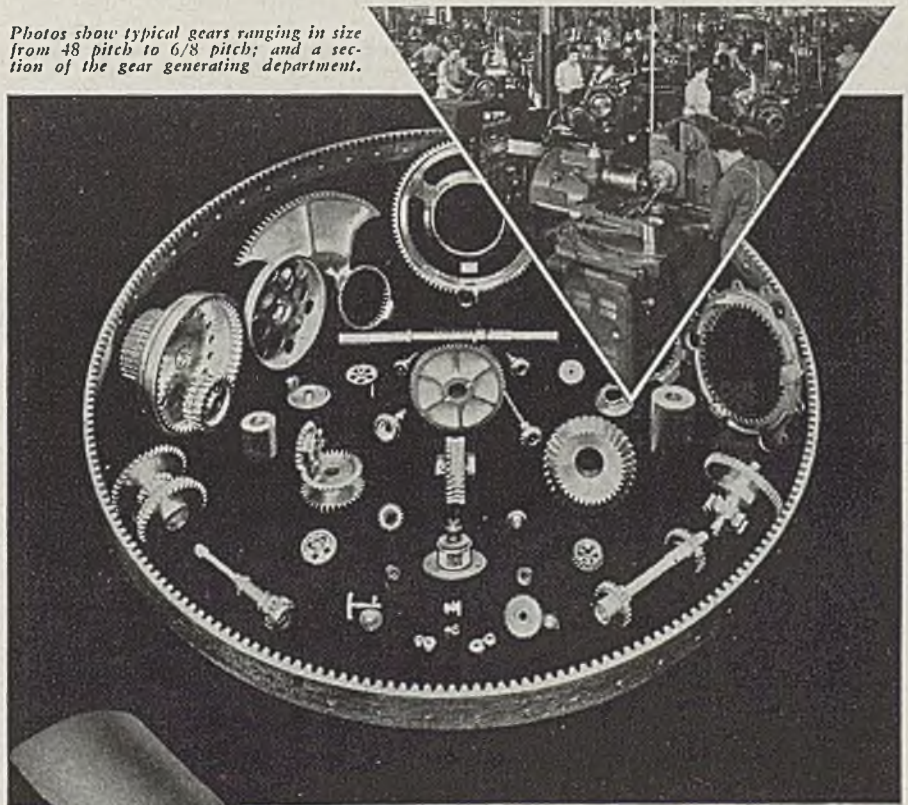

GEARED FOR PRECISION WORK

— ON GEARS • SPECIAL MACHINES and TOOLS
BREHM (Shimmy) TRIMMING DIES • AIRCRAFT ENGINES
and PARTS • CONTRACT MANUFACTURING
COMBUSTIONEER COAL STOKERS

We are prepared to serve you in your Development, Engineering and Manufacturing problems.

Send us your complete specifications today or write for free booklet. At no time do we stock standard gears.

THE STEEL PRODUCTS ENGINEERING CO.

1206 W. COLUMBIA STREET

SPRINGFIELD, OHIO

more iron than would ordinarily be the case; included are pipe shops, including the Providence producers, the Westfield Mass., heating equipment interest and some malleable shops. Increased tonnage to this group is at the expense of others and the balance is spread thinly. Carryover of certified tonnage beyond September will not be large if production holds. Melt is down substantially among foundries and steel works are operating on hand-to-mouth supplies. Resumption of the Troy, N. Y., furnace on low phos will help only a few shops in this district. Mystic iron is badly needed, but return to blast of that furnace is harnessed with multiple economic and legal factors involving subsidy and prices, ore supply and domestic heating coke.

Philadelphia — While CPA recently reduced August purchase authorizations in four areas in an effort to prevent dislocation of supply the action came too late to have much effect in the eastern Pennsylvania district, where a reduction of 10 per cent was ordered for one furnace. Soil pipe producers apparently were not affected by the order and much of the remaining preference tonnage on schedule with this producer for this month had already been shipped. Meanwhile foundries not favored by directives and confronted by further curtailment in operations and in some cases complete suspension are protesting vigorously to Washington for relief. The Birdsboro, Pa., stack recently resumed after relining, now producing foundry

iron but is scheduled to shift to basic Aug. 22.

Buffalo—Although iron output equals the all-time war peak, foundries report supplies are short of requirements. This is attributed in part to emphasis on basic iron to alleviate the scrap shortage. One merchant iron source questions whether all grades of steel now being produced are as essential as some iron grades. Sellers report pressing demands for iron from New England and seaboard consumers. According to reports there were no producers on merchant iron east of here. This has helped to create a serious shortage of iron among New England buyers who report sharp curtailment, or complete suspension in operations.

St. Louis — Mills in this district are in fair shape for pig iron but foundries continue to have difficulty. Pig iron production is at capacity, with incoming supplies hampered by the car shortage. Resumption of the Granite City Steel Co., which takes a large portion of the major pig iron producer here, is expected to curtail supplies to other mills which had benefited in iron from Granite City's shutdown.

Birmingham — Some of the widespread uneasiness over the pig iron situation has disappeared with easement of directive buying regulations by CPA, but iron, on the whole, is not in nearly sufficient quantity to take care of demand. Merchant iron sources estimate a current and probably continuing need, indefinitely at least, for 90 per cent

more iron for this section.

Cincinnati — Foundries holding CPA directives are receiving southern iron but other shipments have been stopped. Melters have avoided shutdowns so far, but the iron supply is precarious, stocks virtually exhausted. Many interests are buoyed by hope that CPA will modify orders. Northern iron is extremely tight but more broadly distributed.

Scrap . . .

No easing appears as many collectors are reported to be holding for increase; some tonnage in barter

Scrap Prices, Page 172

Pittsburgh — Scrap shortage here is not as acute as in Chicago and other key consuming centers, with steel operations continuing at practical capacity. However, mills are consuming scrap at a rate exceeding available supply by a substantial margin. There is little prospect of increased scrap shipments to steel producers' yards until price for preparation is satisfactorily settled. Dealers state little scrap has moved through their yards in recent weeks with considerable tonnage being shipped direct from fabricators to mills on a reciprocal basis. Upgrading is still noted, but tonnage of No. 2 heavy melting steel moving as low phos material, for example, is said to have been substantially reduced with restoration of OPA.

Integrated mills report an unbalanced scrap stock position at some of their plants, necessitating interplant shipments. Such shipments from Carnegie-Illinois Steel Corp.'s plants in Pittsburgh to its facilities at Chicago have exceeded 12,000 tons.

Chicago — Only slight improvement in scrap supply can be discerned in this area. Sufficient time now has elapsed since return of OPA to bring out material which might have been hoarded for higher prices. Lack of evidence of such material moving supports the thinking of those denying that hoarding exists and maintaining scrap is just not available. Several open hearths in the district are being held idle for lack of melting material. Inventories are still being used, raising concern over supplies for fall and winter. Consumers are reaching out great distances and paying springboard to acquire scrap.

Cincinnati — The shortage of scrap is more acute, as melters' reserves shrink. One major interest in the district is down to one-week supply, and others frequently plead for trucked scrap, in emergency tonnage, to avoid shutdowns. There is no agreement on volume withheld in hope of OPA action to raise prices, but this tonnage could not possibly be adequate to relieve anxiety concerning winter needs.

Philadelphia — Scrap sellers are shipping lightly, pending further appeals for higher prices. District steel mills are threatened with further curtailment as a result and are competing with Pittsburgh for such tonnage as is being released.

Detroit — Improvement in flow of production scrap from fabricating plants

JOHNSON

The wire of a thousand uses—mechanical springs in endless varieties . . . antenna rods . . . brick cutting . . . butter cutting . . . choke wire . . . cookie cutters . . . control . . . conveyor belts . . . dental instruments . . . fish leaders . . . flexible shafts . . . mandolin and violin strings . . . mandrels . . . perforating punches . . . piano strings . . . sizing gauges . . . ski binders . . . spark gap gauges . . . tonsil snares . . . trolling lines . . . vibrating screens . . . wire forms . . . sound recording . . . electronics . . . atomic bomb.

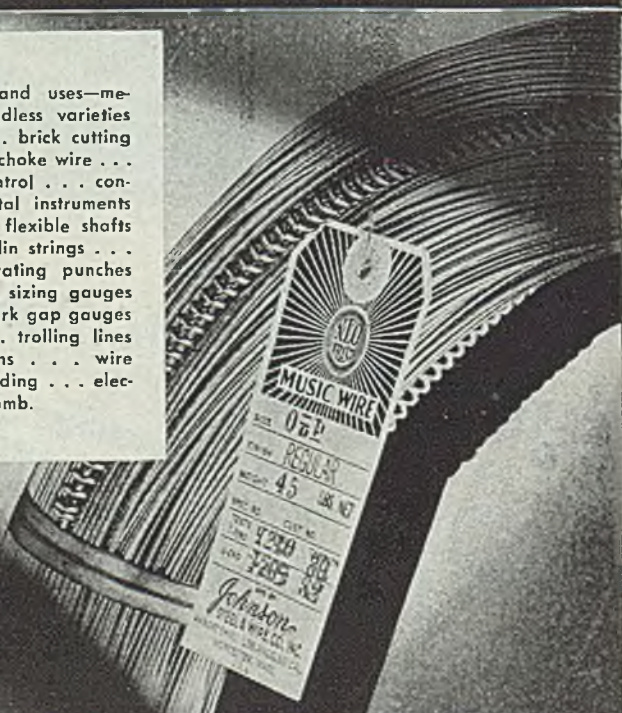

JOHNSON STEEL & WIRE CO., INC.
WORCESTER I, MASSACHUSETTS.

NEW YORK AKRON DETROIT CHICAGO LOS ANGELES TORONTO

in this area is slight at best, and the more pessimistic observers look for no change until the turn of the year. They see an all-out effort to boost production to a profitable level then, reasoning that currently tax carrybacks may dull the incentive for high production. Dealer sentiments on prices vary with the extent of their inventories, those with high inventories wanting higher prices and those with no inventories satisfied with present ceilings.

Boston — Tonnage of scrap held back by the price factor is larger than first supposed and is increasing, as revealed by heavier yard stocks in some instances. Meanwhile demand for steelmaking grades and cast is in excess of offerings, although consumer inventories of the latter vary widely. Steelworks are operating on a close margin and have about reached the limit as to ratio of scrap to pig iron in melts. Production of industrial scrap lags and not much improvement may be expected until fall. At current prices remote scrap is not released.

Seattle — Steel scrap shipments are less than demand and the situation has not eased to the extent expected under revived OPA. Inventories are below normal. Mills are depending on prewar sources, shipyard supply having been practically exhausted, but present prices are not bringing out enough tonnage. The ceiling of \$14.50 is holding but supply is limited by increased cost of preparation, dealers holding back because of lowered margin under ceiling level.

St. Louis — Scrap shipments continue to decline as dealers at collection points await a break in OPA ceilings, which is expected here to approximate \$2. Stocks are reported good at points serving St. Louis, and a price rise should bring in a temporary flood, limited only by railroad car supply. Only the railroads are contributing scrap here now. Last week dealers got about 10 per cent of their normal tonnage. Mill reserves average 30 days or better but foundries are running on a hand to mouth basis, some possessing two or three days' scrap supply.

Birmingham — The scrap situation fails to show improvement. The district's largest steel producer is in relatively good shape, due to the nature of its operations and does not anticipate any real emergency. Others, however, are not so fortunate and the need for scrap is becoming increasingly apparent from week to week.

Warehouse . . .

Warehouse Prices, Page 170

Pittsburgh — Although mill shipments to distributors have shown moderate increase the past few weeks on practically all products, inventories continue unbalanced and well below normal. Warehouse interests as well as steel producers have been requested by CPA to fill out questionnaire indicating how much certified tonnage was shipped, and distribution of this tonnage productwise. Under CC preference rating for fourth quarter, steel distributors are expected to obtain a mill directive similar to that now prevailing under CPA's certified tonnage program.

Fairly active demand is reported for

cold-drawn seamless tubing. Warehouse cold-finished bars and shafting inventories have suffered considerable depletion, as is also the case in nearly all flat-rolled steel items, small bars and wide flange beams. Alloy bar stocks are in good shape with demand relatively small by comparison to other steel items.

Boston — Demand for steel from warehouse precludes possibility of improving inventories despite heavier and better balanced mill deliveries. Substantial volume of new tonnage against overdue orders is moving to consumers against back orders and shipping notices without going into stock. Several producers are concentrating this quarter on warehouse Direction 12 and

are shipping more steel than would otherwise be allocated, although most are below on galvanized sheets because of other certifications. Unless extended, fourth quarter tonnage distribution will be substantially lower, according to some mills' preliminary programs for next quarter. Among carbon products, plates ½-inch and under are tighter with warehouses and stocks of bars in small sizes, bar shape, structural, sheets and strip are low and unbalanced. Buyers seeking tonnage normally supplied by mills are numerous, but pressure has eased in some directions because of shortages of other components slowing up schedules. Most alloy inventories are ample and jobbers are also getting filled

For profitable handling of METAL TURNING CHIPS
Install an
AMERICAN METAL TURNINGS CRUSHER

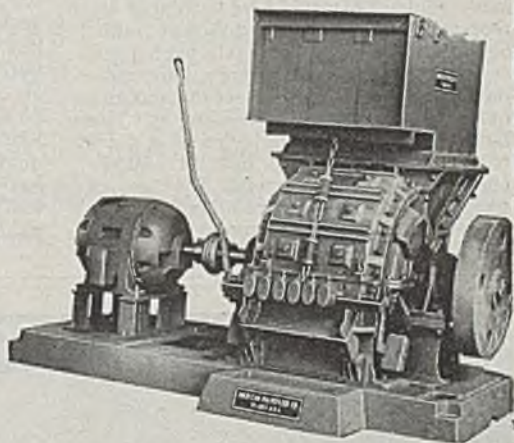

Reducing long, curly turnings to short shoveling chips is a profitable operation with the American Ring Turnings Crusher. Metal turnings of low or high carbon steel, alloy steel, aluminum, brass, and bronze produced from lathes, automatic screw machines, and planers, are easily and rapidly crushed to short shovel turnings, decreasing the bulk of long turnings by 30% to 80%.

Two important features found in the American Ring Turnings Crusher are patented Shredder Rings and the Automatic Apron. Shredder Rings are of Manganese steel and each ring has 20 cutting edges that uniformly reduce turnings by rapid impact. Shredder Rings deflect in contact with tramp metal, thereby, protecting the crusher from possible injury. The automatic apron is a simple, but important device, that has a yielding movement under pressure. Eliminates danger of machine choking from overfeeding and eliminates clogging, such as frequently occurs in a metal trap or catcher.

With the American Ring Turnings Crusher, a big savings is realized in handling labor and storage space, plus cutting oil reclamation yield increase of 30 to 50 gallons per ton. Capacities up to 8 TPH.



PATENTED MANGANESE STEEL SHREDDER RINGS

Send for "Metal Turnings" Bulletin

American PULVERIZER COMPANY
Originators and Manufacturers of Ring Crushers and Pulverizers
1539 MACKLIND AVE. ST. LOUIS 10, MO.

up on larger carbon steel bars, notably cold-drawn.

New York — Although mill shipments are somewhat heavier steel warehouse inventories are barely held by rationing some sizes and products, notably light carbon items including shapes and plates. Numerous industrial steel users, normally mill buyers, are filling in from warehouse pending delivery from mills on orders overdue. This, added to ordinary inquiry, permits no building of inventory. Some distributors have experienced an encouraging improvement in sheet receipts from mills, including galvanized although quotas are small. There is no improvement in nail supply or carbon bars in small sizes. CPA is checking on warehouse distribution third quarter by-products, asking reports as to disposal of certified tonnage and uncertified tonnage shipped.

Tubular Goods . . .

Tubular Goods Prices, Page 169

Cleveland—Production is close to an all-time high in this district and could move higher if steel were available by reopening of idle, less efficient mills. September quotas will remain unchanged at the August level although some producers will be unable to meet this month's quota and others are exceeding it. The latter producers are reducing the order backlog and expect to have it entirely eliminated by the yearend. Shortage of freight cars and ODT regulations covering conservation of rail equipment are delay-

ing shipments. In some instances, mills have been forced to reshuffle schedules to accumulate sufficient tonnage to meet minimum shipping requirements. Producers are gathering data on direct-shipment business for first quarter and will establish quotas for them in that period. Although this type of business has not been accepted for several months, the present backlog cannot be eliminated until around mid-February.

Seattle—Cast iron pipe buyers are placing orders subject to indefinite delivery in 1947. The potential market is large in this area. Snohomish, Wash., has placed 170 tons with H. G. Purcell, Seattle. Bids are in at Seattle for several projects requiring 170 tons. Vancouver, Wash., R. G. Lovett, city clerk, will open bids Aug. 28 for an unstated tonnage of pipe and hydrants.

Nonferrous Metals . . .

Nonferrous Prices, Page 173

New York — Shortages in various shapes, notably finished wire products, continue in copper. Demand for wire is mounting and mill backlogs are heavier. Wire rod supply is short and loss of production by strike restricts output by a leading producer. Deliveries of copper in July totaled 96,826 tons, 75,258 tons foreign metal and 21,568 tons domestic. For delivery over third quarter 30,000 tons of Chilean copper has been bought by the government at 15.75c fob, the same price as the British paid last quarter. The New York equip-

ment for foreign copper has strengthened and business has been done at 16.25c.

Available supply of lead has been reduced by moving ceiling back to 8.25c, New York, and the leading producer has asked for restoration of 9.50c. Metals Reserve Corp. bought 22,500 tons of foreign lead at a price for delivery in this quarter.

The zinc industry expects the ceiling to move back to 9.50c at least but in the meantime business has been stagnant, limited mainly to sales at price at time of shipment. Movement of zinc has been sluggish to the point that consumers are more concerned as to supplies over the next few weeks. Little zinc is produced in this country within the ceiling price. Foreign zinc has brought 10.50c, Gulf ports. Control has snarled distribution of the metal and only lifting of the ceiling in line with production costs appears to be the remedy.

Effect of Rate Increase On Steel Prices Clarified

(Concluded from Page 72)

where freight is a factor in the formula provided under the schedule for figuring a maximum price.

In selling all new iron or steel products other than those mentioned above jobbers may use the higher freight rates only when determining freight charges from shipping point to destination or when determining freight charges from listed cities to destination in figuring lowest combination prices.

Holders of excess stock for which a maximum price is fixed under RPS-49 may use the higher freight rates in figuring maximum prices in any instance where freight is a factor in the formula provided under the price schedule. Resellers of excess stock who do not put the material through warehousing operations may use the higher freight rates in computing the freight factor from the basing point governing the destination to that destination.

Resellers of excess stock who put the material through warehousing operations may apply the higher freight rates to such stock only to the same extent that the higher freight rates are applicable to their regular warehouse stocks of iron and steel products.

STRUCTURAL SHAPES . . .

STRUCTURAL STEEL PLACED

16,000 tons, plant, Celanese Corp., Rock Hill, N. C., to Bethlehem Steel Co., Bethlehem, Pa.

7500 tons, bearing piles, substructure, manufacturing building, General Electric Co., Schenectady, N. Y., to Carnegie-Illinois Steel Corp., Pittsburgh; Stone & Webster Engineering Corp., Boston, contractor-engineer.

2500 tons, addition, gum refining plant, at Oak Tree, N. J., for L. A. Drefuss Co., Staten Island, New York, to Harris Structural Steel Co., New York.

2275 tons, highway bridge, relocation U. S. highway 66, Mitchell, Ill., for U. S. Engineer, St. Louis, to Stupp Bros. Bridge & Iron

LITTELL STRAIGHTENING MACHINE

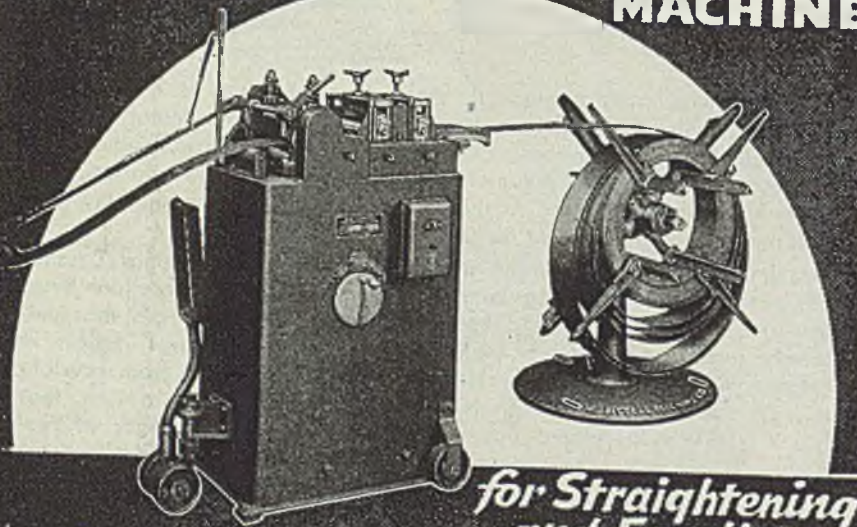

for Straightening
and Feeding
COIL STOCK

FASTER feeding, greater accuracy, improved quality—with Littell press-room equipment. One example, the Littell new-style Continuous Straightening Machine shown. Mounted on fully enclosed steel base, portable, control arms for regulating loop of stock. Pinch rolls 3½" dia. by 8½" long for stock up to 8" wide. Other units for wider stock. Standard speed, 10' to 60' per min. Floor space, 17" x 36". Littell No. 3 Automatic Centering Reel shown, capacity 300 lbs. Littell also makes other press-room units.

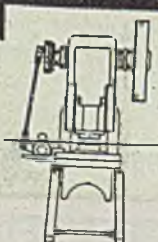

REQUEST
BULLETINS

F. J. LITTELL MACHINE CO.
4165 RAVENSWOOD AVE., CHICAGO 13, ILL.

Co., St. Louis; Bushman Construction Co., St. Joseph, Mo., contractor; bids July 2.

1300 tons, installations, Pennsylvania Power & Light Co., through Foster, Wheeler & Co., New York, to Bethlehem Steel Co., Bethlehem, Pa.

1200 tons, fabricating and furnishing, two state bridges, Hamden, Conn., to American Bridge Co., Pittsburgh.

1120 tons, building, Doubleday & Co., Hanover, Pa., through George A. Fuller & Co., New York City, to American Bridge Co., Pittsburgh.

855 tons, Public School No. 35, Brooklyn, N. Y., through John T. Brady, general contractor, to Lehigh Structural Steel Co., Allentown, Pa.

825 tons, mechanical test building and miscellaneous construction, Bureau of Yards and Docks, Navy, White Oak, Md., to Phoenix Bridge Co., Phoenixville, Pa.; Charles H. Tompkins Co., Washington, general contractor.

700 tons, foundry building, Farrel-Birmingham Co. Inc., Ansonia, Conn., to American Bridge Co., Pittsburgh; Westcott & Mapes, New Haven, general contractor.

500 tons, coal preparation plant, Royalton, Ill., for Franklin County Coal Corp., to American Bridge Co., Pittsburgh.

475 tons, addition, Skokie, Ill., for G. D. Searle & Co., to Mississippi Valley Structural Steel Co., Decatur, Ill.; George A. Fuller Co., Chicago, contractor.

425 tons, boiler and powerhouse, Joseph Schlitz Brewing Co., Milwaukee, to Wisconsin Bridge & Iron Works, Milwaukee, through Kulgian Engineering Co., Philadelphia.

310 tons, supersonic wind tunnels, Bureau of Yards and Docks, Navy, White Oak, Md., to Pittsburgh-Des Moines Steel Co., Pittsburgh; Charles H. Tompkins Co., Washington, general contractor.

285 tons, plant addition, Republic Aviation Corp., Farmingdale, L. I., to American Bridge Co., Pittsburgh.

250 tons, gray iron foundry and office building, Skokie, Ill., for Wells Mfg. Co., to Mississippi Valley Structural Steel Co., Decatur, Ill.; City-Wide Construction Co. Inc., contractor.

230 tons, engineering school, University of Buffalo, to Bethlehem Steel Co., Lackawanna, N. Y.; John W. Cowper Co. Inc., Buffalo, contractor.

200 tons, store addition for Flint & Kent, Buffalo, R. S. McMannus Steel Construction Co., Buffalo; Siegfried Construction Co., Buffalo, contractor.

155 tons, crane runway, Chicago, for Griffin Wheel Co., to Mississippi Valley Structural Steel Co., Decatur, Ill.

110 tons, plant building, Bay State Optical Co., Attleboro, Mass., to West End Iron Works, Cambridge, Mass.; Temple & Crane Inc., Boston, general contractor.

110 tons, office for Bell Telephone Co., Clearfield, Pa., to Bethlehem Steel Co., Bethlehem, Pa.

100 tons, galvanizing building, York Corp., York, Pa., to Bethlehem Steel Co., Bethlehem, Pa.

100 tons, addition for Lake Erie Engineering Corp., Tonawanda, N. Y., to R. S. McMannus Steel Construction Co., Buffalo; Siegfried Construction Co., Buffalo, contractor.

STRUCTURAL STEEL PENDING

4500 tons, New York state bridge; specifications expected out shortly.

1000 tons, power plant, Coffey Dam, etc., St. Mary's Falls, Sault Ste. Marie, Mich., for U. S. Engineers; bids Aug. 14; project postponed indefinitely.

1000 tons, hangars, Brazilian government.
650 tons, chemical specialties building, Toledo, O.

900 tons, factory building, Chicago, for Edith

Crane Builders Since 1903

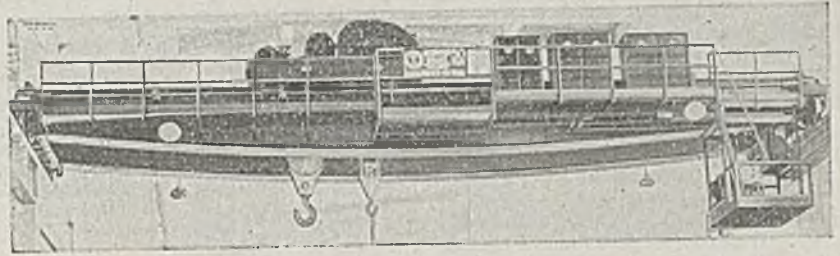

**BEDFORD
CRANES**

Capacities:
**5 to 150
T O N S**
ANY SPAN
OR LIFT

Designed and Engineered
to meet Your Requirements

Send for Your Copy
of Crane Catalog

**ELECTRIC OVERHEAD TRAVELING CRANES
GANTRY CRANES • STEEL DERRICKS
BUILT TO YOUR SPECIFICATIONS
STRUCTURAL STEEL • STEEL BUILDINGS
AIRPLANE HANGARS**

Engineers
Designers
Fabricators

BEDFORD FOUNDRY & MACHINE CO.

Bedford, Indiana, U.S.A.

Gray
Iron
Castings



As WE make it . . .

—so shall you sleep—to awaken refreshed for a busy day in industrial Detroit. Those coveted inner-springs (out for the duration) are still with us!

DETROIT-LELAND HOTEL

800 OUTSIDE ROOMS ALL WITH PRIVATE BATH . . . SINGLE FROM \$2.50 . . . DOUBLE FROM \$4.00

Charles H. Loth, General Manager

Building Corp.

500 tons, board mill, Natchez, Miss., for Ford, Bacon & Davis.

500 tons, three-story office building, General Electric Co., West Lynn, Mass.; Turner Construction Co., Boston, general contractor.

500 tons, kettle house, Colgate-Palmolive-Peet Co., Jersey City, N. J.; project revived.

412 tons, Baltimore & Ohio bridge and underpass at Silver Springs, Md.; bids opened by Maryland State Roads Commission, Aug. 26.

400 tons, warehouse B, Grand Coulee dam, Odair, Wash., for U. S. Bureau of Reclamation. 149 tons, bridge, Sec. 1-F, McLean county, Illinois, for state; bids Aug. 9 with Illinois Steel Bridge Co., Jacksonville, Ill., low.

300 tons, power station, Virginia Electric Co., Oppossum, Va.; Stone & Webster Engineering Corp., Boston, engineer-contractor.

200 tons, temporary work, Staten Island ferry terminal, New York City Department of Marine and Aviation closing bids Sept. 1; this step follows heavy damage to terminal by fire several weeks ago.

200 tons, storage building for American Chain & Cable Co., York, Pa.

100 tons, factory building for Charles Lenning Co., Bridesburg, Pa.

190 tons, Weston's bridge, Saco river, Fryeburg, Me.; bids July 24 rejected.

155 tons, power plant, Bridgeport Brass Co., Bridgeport, Conn.; Stone & Webster Engineering Corp., Boston, engineer-contractor.

120 tons, bridge, Sec. 45-F, Pike county, Illinois, for state; bids Aug. 9 with Illinois Steel Bridge Co., Jacksonville, Ill., low.

Unstated, two-span steel truss state bridge, Independence, Oreg.; plans approved for \$640,000, 1947 construction.

Unstated, laundry building for Buffalo General Hospital, Buffalo.

REINFORCING BARS . . .

REINFORCING BARS PLACED

6500 tons, sewage plant, Chicago, for Sanitary District of Chicago, to Ceco Steel Products Corp., Cicero, Ill.; M. J. Boyle & Co., Chicago, contractor; bids May 23.

1500 tons, four warehouses for Publicker Commercial Alcohol Co. at Linfield, Pa., to Bethlehem Steel Co., Bethlehem, Pa.; also 700 tons for similar warehouse in Millin St., Philadelphia.

355 tons, mechanical test building and miscellaneous construction, Bureau of Yards and Docks, Navy, White Oak, Md., to Rosslyn Steel & Cement Co., Washington; Charles H. Tompkins Co., Washington, general contractor.

175 tons, steel joists, manufacturing building, Lincoln, Ill., for Lehn & Fink Products Corp., to Bethlehem Steel Co., Bethlehem, Pa.; B-W Construction Co., Chicago, contractor.

120 tons, supersonic wind tunnels, Bureau of Yards and Docks, Navy, White Oak, Md., to Rosslyn Steel & Cement Co., Washington; Charles H. Tompkins Co., Washington, general contractor.

REINFORCING BARS PENDING

1500 tons, housing project, South Boston.

1000 tons, power plant, Sault Ste. Marie, Mich., for U. S. Engineer; bids Aug. 14; project postponed indefinitely.

675 tons, Dorena dam, Oregon; bids to U. S. engineer, Portland, Sept. 4.

650 tons, water filtration plant, Hammond, Ind., for city; Joseph J. Duffy Co., Chicago, low on general contract; bids Aug. 10.

515 tons, No. 2 toll office building, Chicago,

for Illinois Bell Telephone Co.; George A. Fuller Co., Chicago, contractor; bids Aug. 12.

124 tons, steel joists, apartment building, Madison, Wis., for University of Wisconsin; George A. Fuller Co., Chicago, contractor.

PLATES . . .

PLATES PLACED

200 tons, storage tanks, Pacific Oil Co., Tiverton, R. I., to Bethlehem Steel Co., Bethlehem, Pa.

PLATES PENDING

200 tons, 10,000,000-gallon welded steel reservoir; Washington, D. C. Suburban Sanitary Commission, Sept. 6; also 15,300 feet, six to 20-inch cast iron pipe, Aug. 23.

Unstated tonnage, plate steel discharge pipes, Columbia Basin project, bureau of reclamation, Denver, Western Pipe & Steel Co. of Calif., San Francisco, \$1,208,000 f.o.b. San Francisco; Puget Sound Machinery Depot, Seattle, \$1,256,019 f.o.b. Seattle, spec. 1338.

Unstated, 70 steel pontoons, Gunderson Bros., Portland, Oreg., low to U. S. engineer. Unstated, 4 million-gallon elevated water tank; bids to Portland, Oreg.; Sept. 4.

PIPE . . .

CAST IRON PIPE PLACED

170 tons, various sizes for Snohomish, Wash., to H. G. Purcell, Seattle, for U. S. Pipe & Foundry Co., Burlington, N. J.

CAST IRON PIPE PENDING

170 tons, several local improvements, Seattle; general bids in.

140 tons, eight-inch, cement-lined, Panama; bids in.

Unstated, various sizes and accessories; bids to R. G. Loveit, Vancouver, Wash., city clerk, Aug. 28.

STEEL PIPE PENDING

Unstated tonnage, 5000 linear feet, 8-inch black; 1000 feet, 12-inch, and 1000 feet, four-inch, water division, District of Columbia; bids Aug. 19.

Unstated tonnage, 32,520 linear feet 14-inches welded steel pipe, 85 fittings, U. S. Engineer, Portland, Ore., Oregon Culvert & Pipe Co., Portland, low, \$64,460.85.

RAILS, CARS . . .

RAILROAD CARS PLACED

Illinois Central, 400 steel hopper cars, to General American Transportation Corp., Chicago.

Northern Pacific, 250 refrigerator cars, to Pacific Car & Foundry Co., Seattle, Wash.

Pacific Fruit Express, 3000 refrigerator cars, 1000 to Mt. Vernon, Ill., plant of Pressed Steel Car Co., Pittsburgh; 500 each to the Pullman-Standard Car Mfg. Co., Chicago; Pacific Car & Foundry Co., Seattle, Wash.; General American Car Transportation Corp., Chicago; and American Car & Foundry Co., New York; these are in addition to 2000 placed earlier in the year and divided equally among the last four mentioned builders.

Western Maryland, 200 fifty-ton steel sheathed box cars, to Bethlehem Steel Co., Bethlehem, Pa.

RAILROAD CARS PENDING

Board of Transportation, New York, 400 steel subway cars, BMT and Independent divisions, rapid transit system; bids Sept. 30.

Western Maryland, 500 fifty-ton hopper cars; bids asked.

LOCOMOTIVES PENDING

National Railways of Mexico; ten 2-5-0 type locomotives, bids asked.

the "BIG IDEA" in every LOVEJOY L-R Flexible Coupling job.

The "big idea" back of every job that leaves our plant, is that each Lovejoy Flexible Coupling must be right for the duties it is intended . . . This close application to the needs of our customers comes about through our engineering service available to everyone, and through close study of our customer's needs in flexible couplings. A wide variety of sizes, cushion materials, etc., is available from stock. Couplings from 1/8 to 2500 H.P. can be furnished. Write today for catalog and quick finding Selector Charts.

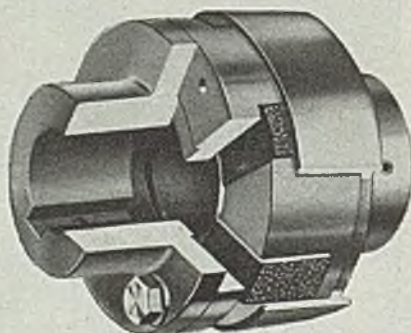

LOVEJOY L-R Flexible Couplings

LOVEJOY Flexible Coupling Co.

Also Manufacturers of IDEAL Mechanical Power Transmission Equipment

5071 W. Lake Street, Chicago 44, Ill.



"HERCULES" (Red Strand) Wire Rope supplies the Durability, Strength, Adaptability, Flexibility and Endurance that "tough jobs in every field" demand. It has been the "Life Line of Steel" for thousands of Plants, Mines, Construction Projects and other operations for over half a century! Yes, wherever wire rope is required for heavy duty, there's a "HERCULES" (Red Strand) type that will fit the job perfectly!

We Invite Your Inquiry.

A. LESCHEN & SONS ROPE CO.
 WIRE ROPE MAKERS
 1808 KENNEDY AVENUE
 NEW YORK • CHICAGO • DENVER
 ESTABLISHED 1857
 ST. LOUIS 12, MISSOURI, U. S. A.
 PORTLAND • SEATTLE • SAN FRANCISCO

THE MAKERS OF *Motorola* RADIOS FIND THIS NEW
ALL STEEL CONVEYOR
Cuts Costs AS IT
Speeds Production



Photo Courtesy Galvin Mfg. Corp.

• The Galvin Mfg. Corporation originally ordered Steel Parts Conveyors for use in their cafeteria. When engineers saw how smooth running, silent and efficient this new steel belt conveyor was, they moved it onto the production lines where, they report, its no-sag flat working surface and trouble-free operation has speeded assembly and inspection beyond all expectations. Galvin is not alone in their enthusiasm for this new all steel conveyor. The list of satisfied users reads like a roll call of the Blue Book of American Industry. It is a conveyor that is ideally suited for countless applications. Find out how the new Steel Parts Conveyor can speed your materials handling job. Mail the attached coupon today.

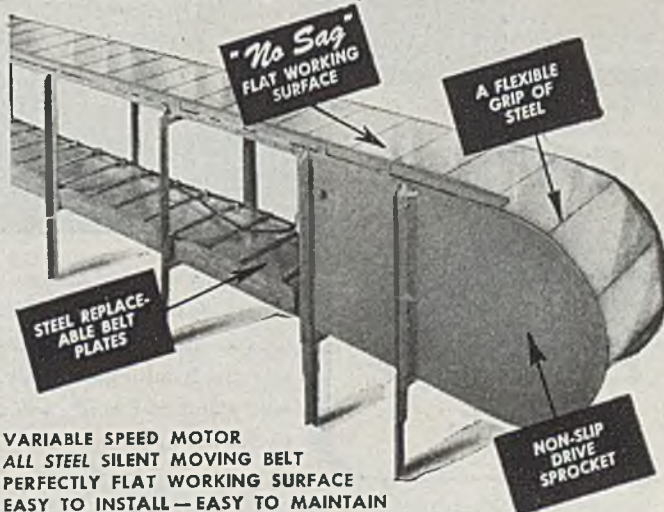

Mail this Coupon Today

For detailed descriptive booklet. Send to:

STEEL-PARTS MANUFACTURING CO.
 DIVISION OF BLACKSTONE MANUFACTURING CO.

218 S. Morgan St., Chicago 7

Name _____ Position _____
 Firm _____ Address _____
 City _____ State _____

THE S F Co.

Lake Superior Iron Ores
 Bessemer
 Non-Bessemer
 Aluminiferous

"Shenango" Pig Iron
 Bessemer
 Malleable
 Basic — Foundry

The SHENANGO FURNACE Company
 Oliver Building, Pittsburgh, Penna.

W. P. SNYDER & COMPANY
 Iron Ore • Pig Iron • Coal and Coke • Oliver Bldg., Pittsburgh, Penna.

CONSTRUCTION AND ENTERPRISE

ALABAMA

OPELIKA, ALA.—J. L. Whatley, president of Board of Commissioners, plans a sewage treatment plant and sewer extensions, to cost \$580,000. Polglaze & Basenberg, Empire Bldg., Birmingham, are consulting engineers.

CONNECTICUT

SHELTON, CONN.—Shelton Tack Co., Canal St., has let contract to F. J. Smith, 76 Minerva St., Derby, Conn., for rebuilding a plant structure at cost of about \$70,000.

ILLINOIS

CHICAGO—Enamel Steel Sign Corp., 2647 West Arthington St., has let contract to H. Borre & Son, 3808 West North Ave., for a two-story 191 x 192-foot plant building, estimated to cost about \$175,000. Michaelson, Rabig & Ramp, 3256 West Franklin St., are architects.

CHICAGO—Ingersoll Steel & Disc Division of Borg Warner Corp., 310 South Michigan Ave., has let contract to Lovis & Raffin, 38 East 116th St., for a one-story 83 x 383-foot plant addition, to cost about \$80,000. L. D. Herb, 7959 South Throop St., is architect.

CHICAGO—Norton Co., 4737 South Christiana St., has let contract to George A. Fuller Co., 111 West Washington St., for a one-story 120 x 220-foot top addition to plant. Mundie, Jensen & McClurg, 39 South LaSalle St., are architects.

LINCOLN, ILL.—Lehn & Fink Products Corp., 683 Fifth Ave., New York, has let general contract to R-W Construction Co., 307 North Michigan Ave., Chicago, for a 427 x 500-foot plant building and 60 x 200-

foot office building here, to cost about \$1,800,000. F. V. Prather, 3 South Michigan Ave., Chicago, is architect.

INDIANA

EVANSVILLE, IND.—Bucyrus-Erie Mfg. Co., E. W. Estes, local manager, plans a plant addition to cost about \$80,000.

FORT WAYNE, IND.—General Electric Co., 1635 Broadway, has plans for a one-story 712 x 842-foot, two-story 45 x 322-foot and 18 x 106-foot plant additions, estimated to cost about \$750,000. J. Gordon Turnbull Inc., 2630 Chester Ave., Cleveland, is architect.

INDIANAPOLIS—Steel Framing Products Co., 1977 Madison Ave., K. Paul Thiery, president, will start fabrication of Quonset huts of various sizes and other steel products.

NEW ALBANY, IND.—Indiana Mfg. Co. Inc., 1900 East Main St., has been incorporated with 200 shares of \$100 par value to manufacture machinery, by Carl K. Helman, Garnett M. Selveking and Harry J. Klein.

IOWA

WEBSTER CITY, IOWA—Charles Closs Co. has let contract to Zitterell Mills, 607 Prospect St., for a plant building to cost about \$75,000.

MARYLAND

BALTIMORE—Keystone Foundry Inc. has let contract for a one and two-story foundry building 40 x 85 feet at 1210 Ridgely St., for production of gray iron castings for electrical work. R. K. Hoke, president of

Keystone Electric Co., is also president of the Keystone Foundry Inc.

BALTIMORE—Armco Drainage & Metal Co. Inc., subsidiary of American Rolling Mill Co., Middletown, O., is building a plant on a five-acre tract on Washington Blvd. for manufacture of metal culvert pipe and storage tanks and to do general metal fabrication. N. R. Cressman is production supervisor, with offices in the Court Square Bldg.

BALTIMORE—International Harvester Co. is building a 400 x 420-foot warehouse and 100 x 140-foot office building on a nine-acre tract at Washington Blvd. and Collins St., with additional units to follow. Present facilities at 81 Mosher St., contain 50,000 square feet floor space.

BALTIMORE—Kelco Corp., 4020 East Baltimore St., manufacturer of dust-collecting, conveying, ventilating and cooling systems, in addition to other sheet metal and stainless steel products, is building a new plant, one story, 150 x 154 feet, at 4015 East Baltimore St., to double output. M. J. Kelly is president.

BALTIMORE—Gilbert Cummins & Co., 2800 Frederick Ave., electroplater, is building a 2000-square foot shipping warehouse with 200-foot loading platform. Gilbert Cummins is president.

BALTIMORE—Marietta Concrete Co., with general offices at Marietta, O., is building a \$100,000 plant on a 7½-acre site at Pulaski Hy. and Race Rd., for manufacture of concrete slabs for silos and storage bins.

MICHIGAN

BANGOR, MICH.—Du-Well Metal Products Inc., Cemetery Rd., has been incorporated with 1000 shares no par value to manufacture die castings, by Ted Bator, Bangor.

DEARBORN, MICH.—Allen Mfg. Co., 12650 Allen Rd., has been incorporated with \$12,000 capital to manufacture tools, dies and fixtures, by Albert Bourgault, 10974 Telegraph Rd., Inkster, Mich.

DETROIT—Rite-Metal Products Co., 19163 Mound Rd., has been incorporated with \$50,000 capital to manufacture machinery, by Roger C. Dolphyn, 5806 Eastlawn Ave.

DETROIT—Dew Spray Products Inc., 517 Dime Bldg., has been incorporated with \$20,000 capital to manufacture water sprinklers, tools and implements, by Paul DiGiovanni, 3978 Canton Ave.

DETROIT—Universal Gear Works Inc., 1301 East McNichols Rd., has been incorporated with \$200,000 capital to manufacture gears, dies and tools, by Samuel R. Greenbaum, 2075 Oakman Blvd.

DETROIT—T. E. K. Industries Inc., 1592 Bates St., has been incorporated with \$50,000 capital to operate a machine shop, by Karl Brenkhart Jr., 26336 Wyoming St.

DETROIT—Multi-Therm Mfg. Co., 11637 Linwood Ave., has been incorporated with \$50,000 capital to manufacture gas burners, furnaces and heaters, by Martin Friedlander, 2902 Burlingame St.

DETROIT—Arrowhead Industries Inc., 1070 Penobscot Bldg., has been incorporated with \$100,000 capital to manufacture metal stampings, by Elmer A. Martindale, 26066 John R St., RFD No. 4, Box 550, Royal Oak Twp.

DETROIT—Edward W. Duffy & Co., 5840 West Jefferson Ave., has been incorporated with \$150,000 capital to manufacture pipe, valves and fittings, by Eva D. Duffy, 8120 East Jefferson Ave.

DETROIT—Bemet Machine Products Co., 4725 Ellery St., has been incorporated with \$50,000 capital to manufacture machine products, by George F. Bean, 2041 Longfellow Ave.

DETROIT—Koppy Tool & Die Co., 3402 Ellery St., has been incorporated with \$200,000 capital to manufacture dies, tools, jigs



**SPECIAL
OR
GENERAL
PURPOSE
USE**

• Standard Euclid Cranes are available in capacities of 3, 5, 7-1/2, 10, 15, 20 and 25 tons in various spans. Over 90% of your material handling requirements can be met with standard Euclids, whether they are put to Special or General Purpose use.

Euclid Crane construction embodies high grade, wide face, coarse pitch gearing

throughout with extra strength shafts and anti-friction bearings to assure longer life and lower power consumption.

THE EUCLID CRANE & HOIST COMPANY

1355 CHARDON ROAD • EUCLID, OHIO



WRITE FOR CRANE CATALOG

Raise Profits

Drop Forgings Now -and Die Production too!

Kropp Forge is again able, for the first time in many years, to offer immediate production of drop forgings, including die-making. Our skilled die-sinkers, who made the dies for millions of military forgings, are at your service.

Kropp drop forgings will give your equipment more dependable performance, lower maintenance costs, less weight and a longer useful life.

For flat die, drop or upset forgings, call the nearest Kropp engineering representative or send blueprints direct for immediate quotation. Production facility is available today!



KROPP FORGE COMPANY
5301 W. Roosevelt Road, Chicago 50, Ill.

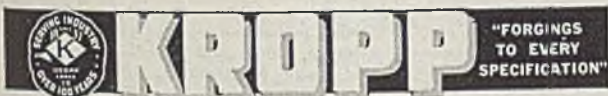

SEAMLESS HIGH PRESSURE GAS CYLINDERS

FOR ALL COMPRESSED
and LIQUEFIED GASES
DIAMETERS UP TO 13"

HOT DRAWN
FROM CARBON MANGANESE
and CHROME MOLY STEELS

Carefully Made
Rigidly Inspected

Other TISCO Products:
MANGANESE STEEL CASTINGS •
ALLOY & CARBON STEEL CAST-
INGS • FROGS • SWITCHES
SPECIAL TRACKWORK
MISC. SEAMLESS TUBING

SINCE  1742

TAYLOR-WHARTON IRON AND STEEL COMPANY

HIGH BRIDGE, N. J. & EASTON, PA.

Cylinder Sales Office: 110 East 42nd St. New York 17, N. Y.

20th CENTURY BLAST

PEENING
SHOT

BLAST CLEANING
ABRASIVES

*The choice of
Leading Plants*

IN FACE OF
WIDE
COMPETITION

Uniform peening calls for the most uniform peening shot—and one that will wear evenly and slowly with minimum shattering.

20th Century Peening Shot is most uniform by actual Rotap tests.

And for blast cleaning use 20th Century Steel Shot and Grit, made by an Exclusive Scientific Heat Treating process. It is so hard, so tough that you can depend on it for maximum service before wearing down to another size range — an important feature because there is a size of abrasive that will do your cleaning most effectively.

Made in all sizes. Write for Samples and Price List.

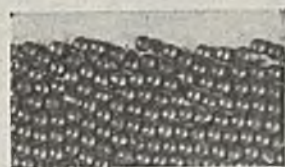

STEEL SHOT



STEEL GRIT



The Cleveland Metal Abrasive Co.

Main Office and Plant:
880 E. 67th Street, CLEVELAND 8, OHIO
Howell Works: Howell, Mich.

When you
want
to go
places..



When you want to go places and see things in Cleveland, it will be more convenient and more pleasant to start from friendly, hospitable Hotel Cleveland. Adjoining Union Passenger Terminal, Garage and Terminal office buildings. Close to stores, theatres, Public Hall, Stadium, boat docks.

**HOTEL
CLEVELAND**
Cleveland, Ohio

and fixtures, by Louis Koppy, 17596 Oak Dr.

DETROIT—Metro Engineering & Mfg. Co., 4501 Belvidere Ave., has been incorporated with \$150,000 capital to manufacture tools, dies, jigs and fixtures, by Frank H. Bob, 17340 Annchester Rd.

OAK PARK, MICH.—Oak Gage & Die Co., 14401 West Eleven Mile Rd., has been incorporated with \$50,000 capital to manufacture tools, dies, gages and fixtures, by George E. Scanlan Jr., 2280 Bacon St., Berkley, Mich.

MISSISSIPPI

NATCHEZ, MISS.—Johns-Manville Corp., 22 East 40th St., New York, has let contract to Ford, Bacon & Davis, 39 Broadway, New York, for a factory estimated to cost about \$5 million.

NEW JERSEY

TRENTON, N. J.—Crescent Insulated Wire & Cable Co., 319 North Olden Ave., has let contract to M. J. Rich, same address, for a 4-story 68 x 70-foot power plant to cost about \$60,000.

NEW YORK

OLEAN, N. Y.—Globe-Union Inc., R. E. Stowe, Olean, in charge, plans a one-story plant for manufacture of spark plugs and roller skates, to cost about \$175,000.

NORTH CAROLINA

CHARLOTTE, N. C.—Whitehead Troy Machinery Co., Wilkinson Blvd., is having plans drawn for a manufacturing building to cost about \$150,000.

OHIO

ASHLAND, O.—Mohican Mfg. Co., recently incorporated by R. C. McCoy, attorney, 10 Farmers Bank Bldg., with \$25,000 capital, will manufacture metal and wood furniture and novelties.

BEDFORD, O.—Master Tool Co., 5605 Herman Ave., Cleveland, has bought a one-story war plant here formerly operated by Ferro Enamel Co., containing 32,000 square feet floor space and will equip for manufacture of pneumatic tools, chrome plating and anodizing. N. M. Brown is president.

CHAGRIN FALLS, O.—Falls Industries Inc., G. Herman Brandt, 2301 Bellfield Rd., Cleveland Heights, O., president, recently incorporated, has received permission from the zoning commission for establishment of a plant for manufacture of small specialty metal items, precisely machined.

CLEVELAND—Forker Corp., 1802 East 47th St., manufacturer of overhead monorail conveyor systems, has bought 2½ acres at 2066 Random Rd., containing a one-story plant building with 14,000 square feet floor space, and will build a warehouse building.

COLUMBUS, O.—National Cylinder Gas Co., 100 North Skidmore St., has let contract to T. J. Schirtzinger Construction Co., 323 West Spring St., for an oxygen and acetylene manufacturing plant to cost about \$150,000.

ELYRIA, O.—American Radiator & Standard Sanitary Corp., Woodford Ave., has expansion program to cost about \$3 million, first development being an addition to steel furnace department, costing \$250,000, other developments to follow. Henry M. Reed Jr., Pittsburgh, is general manager of manufacturing. Frank P. Weil is local manager.

ELYRIA, O.—Milford Rivet & Machine Co., West Riger St., will build a plant addition costing \$45,000, to enlarge capacity for production of tubular and split rivets and cold-headed specialties. J. A. Sharkey is general manager.

SANDUSKY, O.—Bechtel-McLaughlin Inc., 930 West Water St., Ronald W. Bechtel, presi-

dent, will install additional equipment to expand its electroplating production.

OKLAHOMA

BLUTHE, CALIF.—Southern California Gas Co. and Southern Counties Gas Co., 810 South Flower St., Los Angeles, plan a 15,000-hp compressor station to cost over \$850,000. B. M. Laulhere is engineer.

HAWTHORNE, CALIF.—Steel Products Mfg. Co., 3700 Whittier Blvd., Los Angeles, has building permit for a plant building at 12530 South Yukon Ave., Hawthorne, covering 18,000 square feet, to cost about \$40,000.

LOS ANGELES—Dyrr Machinery Works, 3715 East Florence Blvd., Bell, Calif., has permit for shop building at 5719 District Blvd., Los Angeles, covering 3200 square feet, to cost about \$9000.

LOS ANGELES—American Metal Products Co., 2310 Griffith Ave., has let contract for a one-story plant building at 2915 Compton Ave., covering 20,000 square feet, to cost about \$50,000.

LOS ANGELES—Harry Sklar has building permit for a metal stamping plant at 3423 East 22nd St., 40 x 100 feet, costing about \$15,000.

LOS ANGELES—California Metal Enameling Co., 2310 East 51st St., has CPA approval for a plant addition costing \$15,000.

PASADENA, CALIF.—CPA approval has been granted to Fletcher Aviation Corp., 190 West Colorado St., for a storage building at 309 South Raymond St., to cost about \$18,000.

RICHMOND, CALIF.—Parr-Richmond Terminal Corp., 1 Drumm St., San Francisco, plans a foundry, office and warehouse building to cost about \$250,000. E. L. Bloomster, 116 New Montgomery St., San Francisco, is engineer.

SAN FRANCISCO—Pacific Gas & Electric Co., 245 Market St., plans a steam generator plant addition and two 100,000-hp turbine generators and boilers, to cost over \$20 million. Stone & Webster Engineering Corp., 49 Federal St., Boston, are consulting engineers.

VERNON, CALIF.—Harvey Machine Co., 6200 Avalon Blvd., has let contract to Pozzo Construction Co., 2403 Riverside Dr., Los Angeles, for a one-story plant building, to cost over \$75,000.

VAN NUYS, CALIF.—Geo Machine Co. has building permit for a 20 x 40-foot machine shop addition to cost \$10,000.

PENNSYLVANIA

ERIE, PA.—Eric Castings Co., Kenneth T. Guyer, president, is equipping for foundry use a former boiler plant at Sixteenth and German Sts. New equipment is being installed.

NEW HOLLAND, PA.—New Holland Machine Co. is having plans prepared for a plant addition to cost over \$400,000.

PHILADELPHIA—Phillips Petroleum Co., 225 South Fifteenth St., has plans in preparation for a bulk oil plant, estimated to cost \$100,000.

YORK, PA.—York Corp. has plans under way for plant expansion and additional facilities, to cost about \$700,000.

WEST VIRGINIA

COLLIERS, W. VA.—Collier Steel Corp. has an expansion program under way, to cost about \$75,000, including a 60 x 100-foot addition to the stamping building, a similar addition to the assembly building, an electrolytic zinc-plating unit, an infrared drying machine and 15 presses. Ray Carroll is plant manager.

WISCONSIN

SOUTH MILWAUKEE, WIS.—Bucyrus Erie Co., has let contract to Permanent Construction Co., 4100 North Third St., Milwaukee, for a one-story 62 x 380-foot plate shop addition, estimated to cost about \$200,000.

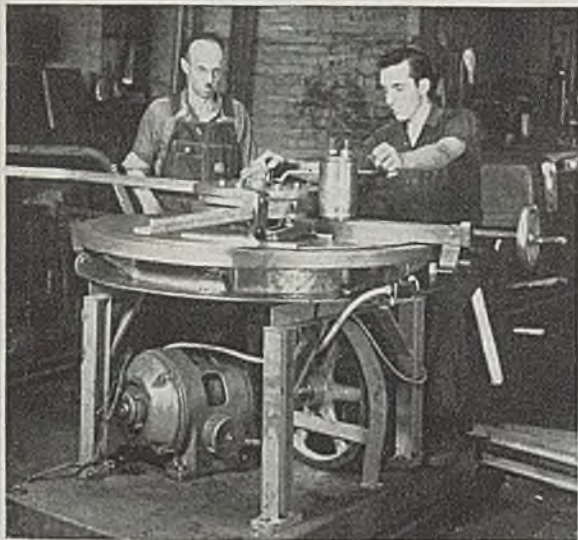

NEW PEDRICK SERVICE

We will job bend pipe and tube on contract. Consult us for rates and delivery.

PEDRICK TOOL & MACHINE CO.

3640 N. Lawrence Street
PHILADELPHIA 40, PA.



and safer, longer, at lower cost—when lubricated with

***LEADOLENE** THE "I.P." LUBRICANT

A product of 70 years research and experience

A large Eastern steel mill using Timken bearings on their 60 inch strip mill specified LEADOLENE, the "I.P." lubricant, with these gratifying results—*"dry necks" were eliminated, grease consumption dropped 33 1/3%, bearing life was greatly increased!*

* Indestructible pH-ilm

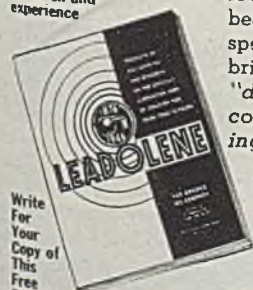

Write For Your Copy of This Free Bulletin

The Brooks Oil Co.

Pittsburgh 19, Pennsylvania · Cleveland, Ohio · Hamilton, Ontario, Warehouses: In Principal Industrial Cities

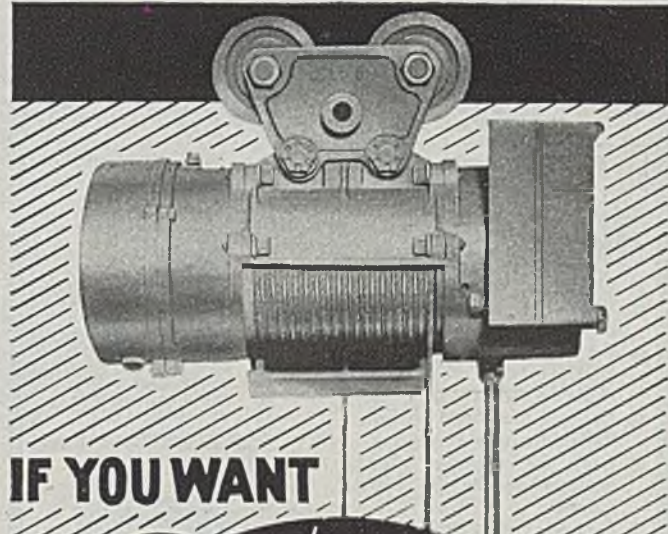

IF YOU WANT

Performance

such as only a Hoist with the following built-in features can give—see the

BOB-CAT

ELECTRIC CABLE HOIST

The Hoist that is
Lighter—More Accessible
SMALLER—STRONGER
dust, fume and moisture proof

Write for interesting facts today.

BOB CAT

ELECTRIC cable HOIST



LISBON HOIST & CRANE COMPANY

PIONEERS OF BETTER HOISTS, LIFTING AND CONVEYING EQUIPMENT

DIVISION OF THE WEIGHT FILE CO

LISBON, OHIO

BEST BY TEST

HI-GRADE
TRADE MARK
Steel

SHOT AND GRIT

For Toughest Blast Cleaning and Surface Peening Operations

SHOT—

- Controlled screening and grading.
- Withstands repeated strain, stress and wear in blasting equipment.
- ITS TENSILE STRENGTH AND TOUGHNESS IS ESPECIALLY ADAPTABLE FOR PEENING.
- Uniform roundness of shot. Pellets are fully utilized on impact.
- Lack of irregular shapes and hollows results in highest efficiency.
- Free from dust and other residue.
- Slowness in wearing down produces longer life and maximum usage.
- Its secret alloying and tempering process prevents rusting and reduces impact fractures.

GRIT

Hi-Grade Grit is thicker, sturdier, tougher. Exceptional abrasive qualities. Its construction gives longer usage. Definitely reduces operating costs.



Write for FREE Test Material

25 Sizes To Meet Your Problem

MANUFACTURERS

CLAYTON SHERMAN ABRASIVES COMPANY
3896 LONYO ROAD • DEPT. C • DETROIT 10, MICH.

It positively...



KEEPS BOLTED ASSEMBLIES permanently TIGHT

BEALL helical SPRING WASHERS have "live action" and constantly exert tightening pressure over a long range. They compensate for ALL causes of looseness including vibration, bolt stretch, wear and break-down of finish under the nut and bolt head.

IN STOCK in all Standard Sizes; made of Carbon Steel, Stainless Steel, Everdur and Duronze.

BEALL TOOL DIV. (Hubbard & Co.)
110 Shamrock St., EAST ALTON, ILL.

BEALL

Spring WASHERS



DIFFERENTIAL STEEL CAR CO., FINDLAY, OHIO



Air Dump Cars, Mine Cars, Locomotives, Lorries
AXLESS Trains and Complete Haulage Systems

P & H

OVERHEAD TRAVELING CRANES • AC and DC ARC WELDERS • WELDING ELECTRODES
WELDING POSITIONERS • ELECTRIC HOISTS
INDUSTRIAL CRAWLER CRANES

4411 W. National Ave., Milwaukee 14, Wis.

HARNISCHFEGER CORPORATION

EXCAVATORS • ELECTRIC CRANES • ARC WELDERS **P & H** HOISTS • WELDING ELECTRODES • MOTORS

Lewis TRAVEL-CUT

AUTOMATIC • HIGH SPEED • HEAVY DUTY

Machines for 1/16" to 3/4" Rod, Rounds and Shapes.
THE LEWIS MACHINE CO., 3450 E. 76th St., Cleveland, Ohio

Wire STRAIGHTENING and CUTTING MACHINES

P

Member Metal Treating Institute

PITTSBURGH

COMMERCIAL HEAT TREATING CO.

49TH ST. & A.V.R.R.

PITTSBURGH, PA.

COMPLETE HEAT TREATING FACILITIES for Ferrous and Nonferrous Metals

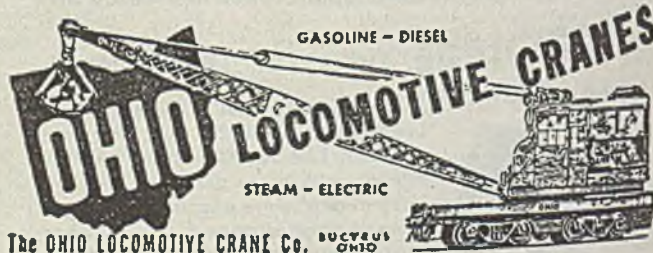

Hobart Simplified Arc Welders

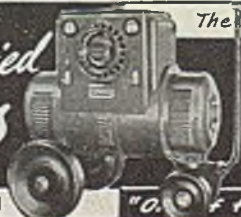

The Fastest Selling Arc Welder on the Market Today

with Dual Control plus "Simplified" Remote Control

FREE Catalog send on request

HOBART BROTHERS CO., Box ST-862, TROY, OHIO

"One of the World's Largest Builders of Arc Welders."

for the
SPEED-UP
that checks
handling
costs

OWEN Scrap GRAPPLES

THE OWEN BUCKET CO.
6012 Breakwater Ave., Cleveland, O.
Branches NEW YORK CHICAGO PHILADELPHIA BERKELEY CAL.

Plenty on the Ball

ACCURACY—CONTROL—DELIVERY
At "Industrial"—teamwork counts!
A line-up of skilled craftsmen and batteries of modern equipment form a combination hard to beat.

"Industrial"

CUT GEARS • SPROCKETS • RACKS
are "big league" calibre.
Wherever outstanding performance is required, look to "Industrial."

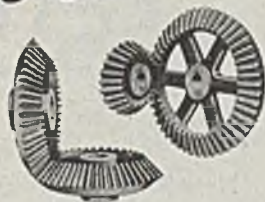

Whatever your needs, it will pay you to consult with "Industrial" engineers. We'll work to your specifications and make "on time" delivery.



Write for our catalog and hand-book on your company letterhead.

INDUSTRIAL GEAR MFG. CO.
4545 VAN BUREN STREET CHICAGO 24, ILLINOIS

ERDLE

SHEET METALS

ORNAMENTAL—INDUSTRIAL

For All Purposes
67 Years of Metal Perforating
Prompt Shipments
Send for Metal Sample Plates

THE ERDLE PERFORATING CO.
171 York Street Rochester, N.Y.

LETTERS & FIGURES FOR EVERY MARKING PURPOSE

"SAFETY" HEAVY BEVEL STAMPS



Here are the most widely known and most practical stamps for all marking purposes. Made of MECCO alloy steel which eliminates dangerous spalling and mushrooming.

- NO SPALLING
 - NO MUSH-ROOMING
 - 25% TO 50% MORE SERVICE
 - LESS FATIGUE
- WRITE FOR LITERATURE

M.E. CUNNINGHAM CO.
SAFETY STEEL STAMPS

172 Carson St., Pittsburgh 19, Pa.

WELDED PRODUCTS FROM OPEN HEARTH AND ALLOY STEELS

Pressure Vessels . . . Galvanizing Kettles . . . Annealing Covers . . . Tin Pots . . . Salt Annealing Pots . . . Wire Annealing Pots . . . and Special Plate Work.

National ANNEALING BOX COMPANY

Pledged to Quality Since 1895
WASHINGTON, PENNA.

API
CODE

ASME
U-68
U-69

STRESS RELIEVING X-RAY TESTING

RYERSON STEELS in Stock

Thousands of kinds, shapes and sizes of steel in stock at eleven plants. Call Ryerson first for prompt action on steel.

Joseph T. Ryerson & Son, Inc.;
Chicago, Milwaukee, St. Louis,
Detroit, Cincinnati, Cleveland,
Pittsburgh, Philadelphia, Boston,
Buffalo, New York.

Steel Makers Since 1871

STRIP STEEL



Hot Rolled—Cold Rolled
Special Carbon—Alloys

The **STANLEY WORKS**

New Britain, Bridgeport, Conn.—Hamilton, Ont.



LADLE SLEEVES • NOZZLES
FOUNDRY GATES • RUNNERS
(Longer Lengths)

Clay Manufacturers Since 1889
Also other Refractories

NATIONAL FIREPROOFING CORPORATION
PITTSBURGH 12, PA.



**For Man-Hour Savings—
For Better, Smoother Work—
USE A "HOLE-HOG"**

- Boring—rough, semi-finish and finish
- Honing
- Milling (special machines)
- Straight Line Drillers
- Universal Adjustable Spindle Drillers
- Way Type Machines—horizontal and vertical drilling, tapping and boring machines.

Since 1901, Moline machine tools have been producing better work, continuously, at greater production and man-hour savings. They are ruggedly built and engineered to fit your particular needs, but are easy to change over to other jobs.

Write us for information concerning machine tool equipment for your special problems.

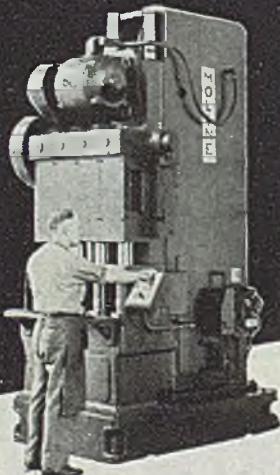

MOLINE TOOL COMPANY
109 20th Street Moline, Illinois

IRON · STEEL · ALLOY · ROUND · FLAT · SHAPES

WIRE

All sizes and finishes
ALSO WIRE SCREEN CLOTH
THE SENECA WIRE & MFG. CO.

FOSTORIA, OHIO



BELMONT IRON WORKS
PHILADELPHIA NEW YORK EDDYSTON

Engineers - Contractors - Exporters
STRUCTURAL STEEL — BUILDINGS & BRIDGES
RIVETED — ARC WELDED
BELMONT INTERLOCKING CHANNEL FLOOR

Write for Catalogue
Main Office — Phila., Pa. New York Office — 44 Whitehall St.

**STEEL
from
STOCK**

Full Warehouse Service
**BARS • STRUCTURALS
PLATES • SHEETS
COLD FINISHED • ETC.**

Write for Monthly Stock List
AMERICAN PETROMETAL CORP.
Broadway at 11th St., Long Island City 2, N. Y.

NOW'S THE TIME TO RE-CONVERT —
NO BETTER AID THAN

SHAWINIGAN CARBIDE



SHAWINIGAN PRODUCTS CORPORATION
350 FIFTH AVENUE, NEW YORK 1, N. Y.

$$\left(2\frac{7}{16} \times 7\right) \times \left(4\frac{7}{8} \times 3\frac{5}{16}\right) =$$

$$17\frac{1}{16} \times \left(\frac{39}{8} \times \frac{53}{16}\right) = 17\frac{1}{16} \times \frac{2067}{128}$$

$$17\frac{1}{16} \times 16\frac{19}{128} = \frac{273}{16} \times \frac{2048}{128} = \frac{273}{16} \times 16 = 273$$

CLOSE FIGURING

by buyers and sellers of good used or surplus machinery and supplies adds up to **STEEL's** "Used and Rebuilt Equipment" section. Rates are moderate . . . results are excellent. Make no mistake about it and send your instructions to **STEEL**, Penton Building, Cleveland 13, Ohio.

Does the **TORCH** You Use
have this *MECO* Advantage?

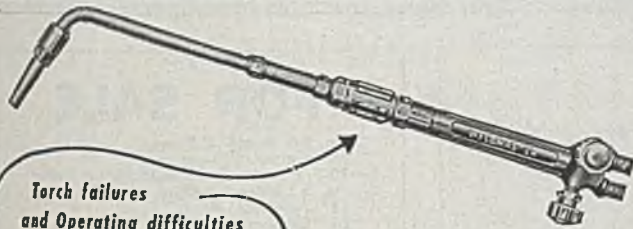

Torch failures
and Operating difficulties
usually begin at
this point

Most Combination and Welding Torches make up on 'metal to metal' joints, and, naturally, over a period of regular use, this joint fails because of 'galling', the accumulation of dust particles and just ordinary wear, BUT, with a MECO Torch, this mechanical failure is easily overcome... that's because we use patented *armored* Gaskets which facilitate QUICK replacement *right on the job*, thus saving 'down time' for factory repairs.

This *one advantage alone* should convince any Welder which make of Torch to choose... but there are *many more just as important*. Get all the facts before you buy *any Torch*.

"There's a MECO Distributor Near You!"

MODERN ENGINEERING COMPANY, Inc.
3401-15 PINE BLVD. ST. LOUIS 3, MISSOURI

STAMPINGS

Ask Us About Them—any small stampings your product may require. Illustrated are just a few of the thousands of diversified forms Hubbard has produced. Look them over; one may be close to what you need. Send in your particular specifications or drawings.

Hubbard also makes Springs, Spring Parts, Wire Forms, all kinds of Cutters.

M. D. HUBBARD SPRING CO.
CENTRAL AVENUE • PONTIAC 12, MICHIGAN

SIMONDS

Helping to solve gearing problems has been our job for many years. Now, more than ever, a dependable gear manufacturer is vital in maintaining your production schedules. Let us help. We produce spur gears up to 12 feet in diameter and of all practical materials. Write for complete information.

Distributors of Ranisey Silent Chain drives and couplings.

THE SIMONDS GEAR & MFG. CO.
25TH STREET, PITTSBURGH, PA.

CUT GEARS

All Types and Sizes

- Baldwin Roller Chain and Sprockets
- Heat Treated Alloy Steel Gears to Customer's Specifications
- Special Gears and Special Gear Units

PITTSBURGH GEAR & MACHINE CO.
2680-2700 Smallman St., Pittsburgh, Pa.

STAINLESS STEEL

—PERFORATED—

TO YOUR REQUIREMENTS
SEND US YOUR DWGS FOR PRICE

ALL SIZE AND SHAPE HOLES—ALL METALS
ARCHITECTURAL GRILLES

SEND FOR CATALOG No. 34

DIAMOND MFG. CO.
BOX 32 WYOMING, PA.

Stampings

- Light—
- Medium—
- Heavy—

For 40 years a reliable source.
Let WHITEHEAD know your requirements.

WHITEHEAD STAMPING CO.
1667 W. Lafayette Blvd., Detroit 16, Mich.

USED and REBUILT EQUIPMENT MATERIALS

★ ★ WANTED ★ ★

WANTED SHEET STEEL COLD ROLLED... GOOD DRAWING QUALITY

S. A. E.—1010—PRIME SHEETS
SIZES

19 GA. 17 x 49	19 GA. 36 x 83	20 GA. 28 $\frac{1}{4}$ x 79
19 GA. 46 $\frac{1}{2}$ x103 $\frac{1}{2}$	19 GA. 39 x 73	20 GA. 35 $\frac{3}{4}$ x 49 $\frac{3}{4}$
19 GA. 68 x 103 $\frac{1}{2}$	19 GA. 44 x 96	20 GA. 36 $\frac{3}{4}$ x 61 $\frac{3}{4}$
	19 GA. 36 x 55	

WHITE MOTOR COMPANY
CLEVELAND 1, OHIO PHONE HENDERSON 2000
Contact E. G. Keller or S. T. Stevens

WANTED

BLACK SHEETS

13 ga.; 14 ga.; 15 ga.; 16 ga.

GALVANIZED SHEETS

26 ga.; 27 ga.; 28 ga.; 29 ga.

Truckloads or Carloads
Wire or Phone Collect for
Specifications

SIEBRING MFG. COMPANY

George, Iowa Phone 43-A

WANTED Late Models

- 2 No. 50 Waterbury Farrel Thread Rollers
 - 1 1-1/2" National Upsetter
 - 1 Zey-Hahneman No. 12 or No. 16 Percussion Press
- 724 Dixie Terminal Bldg.
Cincinnati 2, Ohio

WANTED

STEEL SHEETS

Cold Rolled, also hot rolled primes. All sizes from 24" minimum width to 60" minimum length, in gages from No. 11 to 24 inclusive. For delivery either in Indiana or New Jersey. Contact P. A. Breeze Corporation, Inc., 41 South 6th Street, Newark 7, N. J. Tel. Mitchell 2-7161.

WANTED

LATE TYPE WIRE STRAIGHTENING AND CUTTING MACHINE

WALLACK BROS.

7400 S. Damen Ave. Chicago 36, Ill.

WANTED TO BUY

Several Multiple Spindle Drill Presses With a No. 2 Morse Taper. Can use 3-, 4-, or 6-spindle and require a total of 25 spindles.

COLUMBUS PRODUCTION MFG. CO.
249 E. 5th Avenue Columbus 1, Ohio

Wanted

GAG STRAIGHTENING PRESS

Similar to Sutton No. 2 Single Head Horizontal, capacity 12" x 2" flats, 7-1/2" squares, 8-1/2" rounds. Write giving full details.

FIRTH STERLING STEEL COMPANY
McKeesport, Pa.

FOR SALE

- No. 2A Warner & Swasey
- 36" Cincinnati Planer
- 2-30-1/2 Monarch Automatic Sizing Lathes
- No. 5 Cincinnati Milling Machine
- 42" American Planer
- 24" Cincinnati Shaper
- 3-8" Seneca Falls Lo-Swing Lathes
- No. 3 Warner & Swasey
- 3' Mueller Drill Press
- 26" Niles Lathe
- 18" Lodge & Shipley Lathe
- 24" American Lathe
- 26" Bridgeford Lathe
- 36" Pond Lathe
- 10' Stroke Barnes Double Spindle Drill
- 3-22-1/2" Monarch Lathes
- 30" Niles Engine Lathe
- 44" Niles Engine Lathe
- 36" Monarch Lathe
- 24" Landis Grinder
- 18" Universal Planer
- No. 4 Cincinnati Milling Machine
- 60" Newton Cold Cut Saw
- 3-No. 2 Klemm Metal Cutting Bandsaws
- Baler
- Rotary Heating Furnace
- Continuous Chain type annealing and draw furnace
- Various types of conveyors, flat roll, concave roll, live conveyor sections, overhead and floor type
- Pangborn Shot Blast Equipment
- Hydraulic Accumulator System—Pump, Motors, Bottles—1500 pound pressure
- 340 ton type H H Horizontal Draw Bench
- Detrex Degreaser Unit

Address Box 641,
STEEL, Penton Bldg., Cleveland 13, O.

WANTED

MIDLAND STEEL & EQUIPMENT COMPANY

600 West Jackson Blvd., Chicago, Illinois

The
Largest Buyers
of
Surplus Steel Inventories

Wanted—SHEARINGS

Any Amount—All Sizes, Galvanized, Cold and Hot Rolled Aluminum—Stainless and Copper. 6" Minimum Width to 36" Minimum Length. Uniform Quantities. Gauges from 16 to 30 inclusive.

Write or Wire
Los Angeles Sheet Metal Mfg. Co.
901-903 E. 9th St., Los Angeles 21, Calif.
TRinity 4713

WANTED PRESS EQUIPMENT

Two #3 and One #4 Motor Driven Federal Punch Presses. Would consider other comparable makes. Wire or phone J. W. Wilford, Purchasing Agent, Radio Condenser Co., Davis & Copewood Sts., Camden, N. J.

EQUIPMENT... MATERIALS

\$250,000.00

**WORTH OF HIGH GRADE USED MACHINERY
AND EQUIPMENT TO BE SOLD
AT ONCE INCLUDING:**

- 90—Drill Presses, Delta, Buffalo and other makes. Sizes from 9" to 26".
- 10—Bodine multi-spindle automatic drilling and tapping machines.
- 6—Multi-spindle automatic screw machines and chucking machines; 6-8 spindle, sizes $\frac{1}{8}$ " to $1\frac{5}{8}$ ", standard makes.
- 12—Turret lathes, Bardons & Oliver, Oster, Brown & Sharpe, and others.
- 3—Surface Grinders, Norton and other makes.
- 25—Production Milling Machines; Brown & Sharpe, Pratt & Whitney & other makes.
- 3—Welders—Ames and Marquette.
- 4—Automatic Washing, rinsing and drying machines—Ransohoff and Colt.
- 4—Centrifugal Oil Extraction Machines.

Numerous other equipment including ventilating fans, degreasing units, blueprint equipment, transformers, etc.

CASCO PRODUCTS CORPORATION

512 HANCOCK AVENUE, BRIDGEPORT 2, CONN.

Phone—Bridgeport 6-1801

E. L. Sejman—Charge of Sale

FOR SALE

50,000 STEEL COIL SPRINGS

Compression Type — Flat End
Chrome — Vanadium Steel

In New Perfect Condition — Priced at Fraction of Value

FOR QUICK DISPOSAL

LOT CONSISTS OF THE FOLLOWING

- 30,000 Each — Length 10-3/4" x 2-1/4" OD — 3/8" Wire
- 10,000 Each — Length 7-3/4" x 1-1/2" OD — .225 Wire
- 10,000 Each — Length 6-3/8" x 1" OD — .148 Wire

Further Specifications or Samples Upon Request

MARYLAND PIPE & METALS CO.

304 West Church St., Hagerstown, Maryland

**AVAILABLE FOR IMMEDIATE DELIVERY
SEVERAL ELECTRIC HEAT TREATING FURNACES**

General Electric Type RRB36

Door opening 3 ft. wide; 2 ft. high; with 6 ft. of hearth.
72 KW capacity. 220 Volt, 3 Phase, operating current.

Each complete with recording potentiometer having range from 200 to 2000 degrees F. and magnetic contactor and disconnect switch.

LELAND-GIFFORD COMPANY

Worcester, Mass.

FOR SALE

250,000 LBS. SOFT STAINLESS STEEL WIRE

TYPE 307 IN FULL COILS • SIZES 1/4", 5/16", 9/32"

MANUFACTURED BY UNIVERSAL CYCLOPS AND ALLEGHENY

Each coil tagged for grade, heat specifications, etc. Will sell entire lot at 12c per pound f.o.b. Boston

SOMERSET SURPLUS CORPORATION
SOMERVILLE, MASS.

BLEACHERY COURT
SOMerset 3460

FOR SALE

1—#5 REED PRENTICE JIG BORER and Vertical Boring Machine. Complete with 7 1/2 HP Motor.

1—NEW HAVEN KEY SLOTTER 32" Dia. Table with 2 HP Motor.

1—BARRETT HORIZONTAL BORING MILL. Cuts up to 40" Dia. Circle, with countershaft.

1—BARRETT HORIZONTAL BORING MILL. Cuts up to 36" Dia. Circle, with countershaft.

1—Barnes 22" SWING HYDRAM DRILL with Hoeffler EC4 Head, Direct Connected to 5 HP Motor.

Contact R. W. Homan, Pur. Agt.

THE C. H. DUTTON CO.

638 Gibson St. Kalamazoo 6, Mich.
Phone 3-1675

FOR SALE

ALLOY STEEL

ROUND, HEX, SQUARE BARS

New York and Pittsburgh
Warehouse Stocks

L. B. FOSTER CO.

9 Park Place, New York 7
Phone—Barclay 7-2111

P. O. Box 1647, Pittsburgh 38
Phone—Walnut 3300

Michigan Distributor
C. J. GLASGOW COMPANY
2085 Fenkell Ave., Detroit 3
Phone—Townsend 8-1172

RAILS NEW AND RELAYING

TRACK ACCESSORIES

from **5** Warehouses

- PROMPT SHIPMENTS
- FABRICATING FACILITIES
- TRACKAGE SPECIALISTS

EVERYTHING FROM ONE SOURCE

L. B. FOSTER COMPANY

**PITTSBURGH CHICAGO
NEW YORK SAN FRANCISCO**

RELAYING RAIL

TRACK ACCESSORIES

MIDWEST STEEL CORP.

Gen'l Off. CHARLESTON, 21, W. VA.
Warehouses
CHARLESTON, W. VA.
KNOXVILLE, TENN. • PORTSMOUTH, VA.

USED and REBUILT EQUIPMENT MATERIALS

FOR SALE

1—Type D-4840 AJAX HULTGREN SALT BATH HARDENING FURNACE, operating at 220 volts, 2 phase, 4 wire, 60 cycle. Working dimensions 48" x 20" x 20" deep. For use with nitrate salt, drawing operation 350 deg. F. to 1150 deg. F., complete with electrical control equipment including 40 KW, 220 volt, 2 phase, 4 wire, 60 cycle transformer.

1—Type H-4875 AJAX HULTGREN SALT BATH HARDENING FURNACE, operating at 220 volts, 2 phase, 4 wire, 60 cycle. For use with neutral salt, hardening operating 1100 deg. F. to 1700 deg. F. Complete with electrical control equipment including 75 KW, 220 volt, 2 phase, 4 wire, 60 cycle transformer.

F. C. CASTELLI COMPANY
Erie Ave. and F St. Philadelphia 34

FOR SALE NEW CUPRO-NICKEL TUBES

100,000 lbs. 1/2" OD x 18 ga. Wall 80%
and 48" Lengths.

BRASS — COILS

30,000 lbs. .115 x 15/16—1/2 Hd.—Sheared Edge.

SEABOARD STEEL CO.

New Haven, Conn.
Telephone: 8-0929 8-2034

FOR SALE

6,000 lbs.—.034" Dia. Galv. Cast Steel Rope Wire
10,000 lbs.—.029" Dia. Premier Spring Wire
Above Items in catch weight coils approx. 75 lbs. each.

ROYERSFORD SPRING CO.
Royersford, Pa.

FOR SALE

HILLES AND JONES PLATE ROLLS

Pyramid type, motorized with reversing switch, capacity 3/8" plate, 78" wide. Write for inspection or photograph. Location Eastern Seaboard. Can be seen in operation.

Address Box 648,
STEEL, Penton Bldg., Cleveland 13, Ohio

FOR SALE

2—Metal Alligator Shears

Address Box 335

STEEL, Penton Bldg., Cleveland 13, O.

ROLLING MILLS and EQUIPMENT

FRANK B. FOSTER

829 OLIVER BLDG. PITTSBURGH, PA.
Cable Address "FOSTER" Pittsburgh

CRANES & LOADERS

2—Northern Engineering 10 ton, 14' Hlt. hand operated Bridge Cranes; 1-45' span, 1-38' span.
1—Northern Engineering 4 ton, 46' span, 230 volt D.C. Electric Crane, 3 motor, steel cab, No. 5060 (Monorail horizontal travel.)

WIRE—WRITE—PHONE

Send for Printed Circular

NEWBERRY MANUFACTURING CO.

P. O. Box 295 Newberry, Mich.
Tel: Newberry 16

HAMMERS, 4-B Nazel, 5" x 5" M.D.
LATHE, Turret 24" Gisholt, 6 1/4" hole.
PRESS, Forging 1000 ton United Steam-Hyd.
PLANER, O. S. 60" x 60" x 14' D&H, M.D.
SHAPER, 36" Morton Draw Cut.
SHEARS, Alligator 1"-4".
SHEAR, Open End 22" blades 2 1/2" sq. M.D.
SLOTTER, 12" Putnam, 35" table, B.D.
STRAIGHTENER, Plate, 110" x 1 1/4", H&J.
STRAIGHTENER, 1/2" x 40' Shuster, M.D.
WEST PENN MACHINERY COMPANY
1208 House Bldg. Pittsburgh 22, Pa.

FOR SALE

SCIACKY ALUMINUM SPOT WELDER

50 K.W. Type 2S5 PMCO. Perfect condition. Two years old. Used 6 months. Can be seen in operation.

S. B. MFG. CO.

34 - 34th St., Brooklyn 32, N. Y.
South 8-5222

1—Henley Horizontal Type Hydraulic Lead Extrusion Press

3100 Ton Cap.—Complete with Gas Fired Melting Pot and all gages, etc.—No Pump
New 1932—Serial No. 7317
Can be inspected at Plant where located.
SEABOARD STEEL CO. Tel. 8-0929
New Haven, Conn. 8-2034

Steel storage space available.
Overhead crane—10 tons capacity.
12 car R.R. siding.

WALLACK BROS.

7400 S. Damen Ave. Chicago, Ill.

Use This Section

When you have machinery or equipment you want to sell—STEEL can help you. For rates, write STEEL, Penton Bldg., Cleveland.

CONTRACT WORK

SPECIAL MANUFACTURERS TO INDUSTRY...Since 1905

Metal Specialties comprised of STAMPINGS, FORMING, WELDING, SPINNING, MACHINING. All Metal or Combined with Non-Metal Materials

WRITE FOR FOLDER
LARGE SCALE PRODUCTION
OR PARTS AND DEVELOPMENT ONLY

GERDING BROS.

SE THIRDVINE ST. • CINCINNATI 2, OHIO

FIRM BID QUOTATIONS ON ALL TYPES OF DESIGN AND DETAILING

Structural Steel and Reinforced Concrete

TUMARKIN & EMERMAN

Licensed Prof. Engineers—Designers
33 Whitehall St., New York, N. Y., BO. 9-3269

Send us your inquiries on PRODUCTION PARTS AND ASSEMBLIES

Viking High Speed Tool Bits
Special Taps

Commercial Heat Treating
Electro Plating

AGERSTRAND CORPORATION
Muskegon, Michigan

SAY IT HERE

If you have facilities to handle additional work. An advertisement in this section will tell others of your capacity, etc. Write STEEL, Penton Bldg., Cleveland 13.



Representatives Wanted

DISTRIBUTOR OR FACTORY REPRESENTATIVE

To represent midwest manufacturer of quality blast cleaning and surface peening, STEEL SHOT AND GRIT, for use in foundries, drop forge, heat treat and misc. metal industries. No objection to other lines. Field co-operation and national advertising. Substantial commissions. Write for information. Address Box 588, STEEL, Penton Bldg., Cleveland 13, O.

Positions Wanted

GENERAL OR FACTORY MANAGER INVITES contact with Corporation Officers, in seeking position of executive responsibility with progressive concern in sheet metal products and stamping business. Applicant has specialized in this industry for 24 years on all elements of factory operations and sales. Experience covers greatly diversified products, in light, medium and heavy construction, for small quantities and mass production. Well acquainted over wide field of large and small contractors. Efficient organizer with A-1 record. Reply: Box 624, STEEL, Penton Bldg., Cleveland 13, O.

ASSISTANT SUPERINTENDENT OR GENERAL Foreman. 17 years' experience forging business in supervision of drop, board and upset forging. Married, age 41. Best of references. Available immediately. Will go anywhere here or abroad. Address Box 651, STEEL, Penton Bldg., Cleveland 13, O.

SUPERINTENDENT, HEAT TREAT — YOUNG, aggressive, 11 years experience all alloys and methods. Tool forging and treating a specialty. Willing to relocate for position with good present and better future. Prefer dry climate. Address: Box 632, STEEL, Penton Bldg., Cleveland 13, Ohio.

MELTER—MAN WITH FOUR YEARS' EXPERIENCE as melter in basic open hearth practice, desires steady position with reliable company. Will answer all correspondence immediately and sincerely. Address Box 643, STEEL, Penton Bldg., Cleveland 13, O.

SALES METALLURGIST—AGE 31; PERSON-ABLE and reliable young steel salesman desires position covering Philadelphia and vicinity for first-class mill or warehouse distributor. Address Box 644, STEEL, Penton Bldg., Cleveland 13, O.

23 YEARS' EXPERIENCE WITH LARGE rolling mill, structurals, plates, bars, sheets; order handling, mill scheduling, customer contacts. Can handle sales or purchasing. Address Box 642, STEEL, Penton Bldg., Cleveland 13, O.

IF YOU HAVE AN OPPORTUNITY TO OFFER

Use the "Help Wanted" columns of STEEL. Your advertisement in STEEL will put you in touch with qualified, high-calibre men who have had wide training in the various branches of the Metal Producing and Metalworking industries.

Help Wanted

SALES-EXECUTIVE ASSISTANT

wanted to take over sales supervision under vice-president of well-established raw materials company of excellent reputation selling to steel mills and foundries. Position offers opportunity to assume sales management. Must be sales and commercial-minded with actual selling experience. Metallurgical knowledge desirable but not essential. Age 40-45.

State experience, references and salary expected. All replies confidential. Address Box 634, STEEL, Penton Bldg., Cleveland 13, Ohio.

SALES MANAGER

With successful sales record by one of the leading manufacturers in the metal cutting tool industry. State age, education, experience, special qualifications and compensation desired. Address Box 627, STEEL, Penton Bldg., Cleveland 13, O.

EXPERIENCED PLATE DESIGNER AND ESTIMATOR WANTED

Excellent opportunity, large plant located in the South. Give references.

Address Box 640
STEEL, Penton Bldg., Cleveland 13, O.

WANTED: PRODUCTION ENGINEER WHO is qualified to arrange machinery and welding equipment, both hand and automatic, to get maximum production on various sizes and thicknesses of A.S.M.E. Code tanks, towers and other items fabricated from sheets and plates. Must have past record in sheet and steel plate fabricating shop. Address Box 623, STEEL, Penton Bldg., Cleveland 13, O.

Employment Service

SALARIED POSITIONS \$2,500-\$25,000. THIS thoroughly organized confidential service of 36 years' recognized standing and reputation carries on preliminary negotiations for supervisory, technical and executive positions of the calibre indicated through a procedure individualized to each client's requirements. Retaining fee protected by refund provision. Identity covered and present position protected. Send only name and address for details. R. W. BIXBY, INC., 110 Dun Bldg., Buffalo 2, N. Y.

CLASSIFIED RATES

All classifications other than "Positions Wanted," set solid, minimum 50 words, 7.00, each additional word .14; all capitals, minimum 50 words 9.00, each additional word .18; all capitals leaded, minimum 50 words 11.00, each additional word .22. "Positions Wanted," set solid, minimum 25 words 1.75, each additional word .07, all capitals, minimum 25 words 2.25, each additional word .09; all capitals, leaded, minimum 25 words 2.75, each additional word .11. Keyed address takes seven words. Cash with order necessary on "Positions Wanted" advertisements. Replies forwarded without charge. Displayed classified rates on request. Address your copy and instructions to STEEL, Penton Bldg., Cleveland 13, Ohio.

Help Wanted

POSITION AVAILABLE

Raw material salesman, age 30 to 40, with experience in selling to steel plants and foundries, wanted by well-established producer with excellent reputation in the field. Territory—east central states. Salary, traveling expenses and bonus.

State experience, references and salary expected. All replies confidential. Address Box 633, STEEL, Penton Bldg., Cleveland 13, Ohio.

FORGE SHOP SUPERINTENDENT

Established forge shop, operating steam and board drop hammers, requires capable man as shop superintendent.

Must be capable of supervising die shop producing drop and upset dies and be responsible for production in drop forge and upset departments. Thorough knowledge of upsetter die design and operation needed.

Address Box 645,
STEEL, Penton Bldg., Cleveland 13, O.

MELTER

Technically trained man capable of taking charge of electric melting department. Must have had experience on high alloy and carbon steel.

Address Box 647
STEEL, Penton Bldg., Cleveland 13, O.

MASTER MECHANIC

Reolling mill desires Master Mechanic to take complete charge of all maintenance and construction. Must have 15 or 20 years all around experience in mills. Reply Box 646, STEEL, Penton Bldg., Cleveland 13, O.

STRUCTURAL STEEL DRAFTSMAN FOR work with small fabricating shop in Florida. Prefer man who has had experience detailing for welded construction. Give references and experience first letter. Address Box 639, STEEL, Penton Bldg., Cleveland 13, O.

CHIEF DRAFTSMAN: REQUIRED FOR structural steel Drafting Room Baltimore. Annual capacity 12,000 tons. Give complete data regarding education, experience, salary desired, and when available. Address: Box 631, STEEL, Penton Bldg., Cleveland 13, O.

WANTED: ESTIMATOR, YOUNG ENGINEER or man having Structural Drawing Room experience. Location Eastern Pennsylvania. Address. Box 638, STEEL, Penton Bldg., Cleveland 13, O.

ADVERTISING INDEX

A		Ferry Cap & Set Screw Co., The 27	O	
Adams, R. P., Co., Inc. 13		Fallansbee Steel Corporation 18	Ohio Locomotive Crane Co., The 190	
Agerstrand Corp. 196		Foote-Burt Co., The 29	Owen Bucket Co., The 191	
Air Reduction 58		Foster, Frank B. 196	P	
Alliance Machine Co., The 2		Faster, L. B., Co. 177, 195	Page Steel & Wire Division, American Chain & Cable 146	
American Brake Shoe Co., National Bearing Division 35		G		
American Chain & Cable, Page Steel & Wire Division 146		General Chemical Co. 38	Pedrick Tool & Machine Co. 189	
American Chemical Paint Co. 161		General Steel Warehouse Co., Inc. 116	Phillips Screw Manufacturers 53	
American Gas Association 3		Gerding Bros. 196	Pittsburgh Commercial Heat Treating Co. ... 190	
American Institute of Bolt, Nut & Rivet Manu- facturers 44, 45		Gisholt Machine Co. 21	Pittsburgh Gear & Machine Co. 193	
American Magnesium Corporation 166		Granite City Steel Co. 28	Pittsburgh Plate Glass Co., Brush Division .. 22	
American Petrametal Corp. 192		Great Lakes Steel Corporation 17	Plymouth Locomotive Works 19	
American Pulverizer Co. 181		Greenfield Tap & Die Corp. 60	Protected Steel Products 57	
American Rolling Mill Co., The, Rustless Iron & Steel Division 23		H		
American Shear Knife Co. 162		Harnischfeger Corporation 190	R	
Anaconda Wire & Cable Co. 163		Harper, H. M., Co., The 91	Rathborne, Hair & Ridgway Co. 34	
Atlas Car & Mfg. Co., The 154		Harrisburg Steel Corporation 42	Russell, Burdsall & Ward Bolt & Nut Co. 118, 119	
B		Heald Machine Co., The Inside Front Cover	Rustless Iron & Steel Division, The American Rolling Mill Co. 23	
Baker-Roulang Co., The 152		Hobart Brothers Co. 190	Ryerson, Joseph T., & Son, Inc. 192	
Baldwin Locomotive Works, The, Locomotive & Southwark Division 46		Homestead Valve Mfg. Co. 43	S	
Bantam Bearings Division, The Torrington Co. 6		Horsburgh & Scott Co., The 144	Salem Engineering Co. 20	
Barber-Colman Co. 39		Hubbard, M. D., Spring Co. 193	Seneca Wire & Mfg. Co., The 192	
Beall Tool Div. Hubbard & Co. 190		I		
Bedford Foundry & Machine Co. 183		Ingalls Iron Works Co., The 159	Sharon Steel Corporation 5	
Belmont Iron Works 192		Industrial Gear Mfg. Co. 191	Shawinigan Products Corporation 192	
Bethlehem Steel Co. 1		Inland Steel Co. 65	Shenango Furnace Co., The 185	
Birdsboro Steel Foundry & Machine Co. ... 32		J		
Bixby, R. W., Inc. 197		Jeffrey Manufacturing Co., The 158	Snyder, W. P., & Co. 185	
Blaw-Knox Division of Blaw-Knox Co. 176		Johnson Steel & Wire Co., Inc. 180	Socony-Vacuum Oil Co., Inc. 47	
Bohn Aluminum & Brass Corp. 123		Jones & Laughlin Steel Corp. 115	Sammer & Adams Co., The 56	
Boston Woven Hose & Rubber Co. 14		K		
Brooks Oil Co., The 189		Kearney & Trecker Corporation 36, 37	South Bend Lathe Works 56	
Bullard Co., The 82		Kropp Forge Co. 187	Square D Co. 129	
Burt Mfg. Co., The 156		L		
C		Latrobe Electric Steel Co. 155	Stanley Works, The 192	
Cadman, A. W., Mfg. Co. 178		Lebanon Steel Foundry 54	Steel-Paris Manufacturing Co., Division of Blackstone Manufacturing Co. 185	
Carpenter Steel Co., The 107		Lepel High Frequency Laboratories, Inc. ... 50	Steel Products Engineering Co., The 179	
Chandler Products Corp. 111		Leschen, A., & Sons Rope Co. 185	Steel & Tube Division, The Timken Roller Bearing Co. 121	
Cincinnati Bickford Tool Co., The 59		Lewis Machine Co., The 190	Starling Grinding Wheel Division of the Cleveland Quarries Co. 138	
Clayton Sherman Abrasives Co. 190		Lincoln Electric Co., The 40, 41	Stakerunit Corporation 175	
Cleveland Automatic Machine Co., The 141		Linda Air Products Co., The 12	Strong Steel Foundry Co. 125	
Cleveland-Cliffs Iron Co., The 31		Lisbon Hoist & Crane Co. 189	Superior Steel Corporation 125	
Cleveland Crane & Engineering Co., The ... 131		Littell, F. J., Machine Co. 182	T	
Cleveland Hotel 188		Locomotive & Southwark Division, The Bald- win Locomotive Works 46	Taylor-Wharton Iron & Steel Co. 187	
Cleveland Metal Abrasive Co., The 187		Lovejoy Flexible Coupling Co. 184	Texas Co., The 66	
Cleveland Tramrail Division, The Cleveland Crane & Engineering Co. 131		M		
Cleveland Worm & Gear Co., The Inside Back Cover		Macwhyte Co. 7	Tide Water Associated Oil Co. 15	
Cold Metal Products Co., The Front Cover		Maehler, Paul, Co., The 151	Timken Roller Bearing Co., The, Steel & Tube Division 121	
Cone Automatic Machine Co., Inc. 77		Mathews Conveyor Co. 150	Torrington Co., The, Bantam Bearings Di- vision 6	
Continental Foundry & Machine Co. 51, 52		Mesta Machine Co. 109	U	
Continental Steel Corporation 143		Michigan Steel Tube Products Co. 113	Union Carbide & Carbon Corp. 12, 48	
Cunningham, M. E., Co. 191		Midland Steel & Equipment Co. 194	V	
Cutler-Hammer, Inc. Back Cover		Midwest Steel Corp. 195	Vickers, Inc. 85	
D		Modern Engineering Co., Inc. 193	W	
Detroit-Leland Hotel 183		Moline Tool Co. 192	Wapakoneta Machine Co., The 126	
Detroit Power Screwdriver Co. 160		Morgan Construction Co. 62	Washburn Wire Co. 33	
Detroit Sheet Metal Works 49		N		
Diamond Mfg. Co. 193		National Annealing Box Co. 191	Weirton Steel Co. 196	
Differential Steel Car Co. 190		National Bearing Division, American Brake Shoe Co. 35	West Penn Machinery Co. 193	
DoAll Co., The 53		National Fireproofing Corporation 192	Whitehead Stamping Co. 16	
Dow Chemical Co., The 153		National Machinery Co. 9	Willson Products, Inc. 137	
E		National Steel Corporation 17, 33	Wisconsin Steel Co. 8	
Electric Controller & Mfg. Co., The 148		Nox-Rust Chemical Corporation 149	Worth Steel Co. 8	
Electric Storage Battery Co., The 147		P		
Electro Metallurgical Co. 48		Youngstown Sheet & Tube Co., The 26	Y	
Elwell-Parker Electric Co., The 24		Table of Contents, Page 61		
Erdle Perforating Co., The 191		Classified Advertisers, Pages 194, 195, 196, 197		
Euclid Crane & Hoist Co., The 186		STEEL		
Ex-Cell-O Corporation 93				
F				
Fate-Root-Heath Co., The 19				
Federal Machine & Welder Co., The ... 10, 11				