

Vasyl YATSKIV
Ternopil National Economic University
Research Institute for Intelligent Computer Systems

THE NETWORK CODING METHOD IN WIRELESS SENSOR NETWORKS BASED ON RESIDUE NUMBER SYSTEM

Summary. The paper presents and investigates the method of network encoding in the residue number system for usage in wireless sensor networks. The method of encoding provides increase of total network bandwidth by choosing coprime digit capacity different modules and different routes of transmission residues.

METODA SIECIOWEGO KODOWANIA DANYCH W BEZPRZEWODOWYCH SIECIACH SENSOROWYCH NA PODSTAWIE SYSTEMU RESZTOWEGO

Streszczenie. W artykule zaproponowano i zbadano metodę kodowania sieciowego w systemie resztowym do stosowania w bezprzewodowych sieciach sensorowych. Opracowana metoda kodowania zwiększa ogólną przepustowość sieci dzięki wyborowi względnie pierwszych modułów o różnej pozycyjności i przesyłaniu reszt przez różne trasy.

1. Introduction

The task of wireless sensor networks (WSNs) is data collection from distributed sensors over wide areas of the physical parameters. WSNs are effectively used in systems of environmental, technical, and medical monitoring.

At present the increase of the duration of the network from autonomous power source, increasing total bandwidth and reliability of data are among the unresolved problems of WSNs.

It is shown in [1] that the most energy-consuming operation in WSN is data transmission, which constitutes over 70%. Reducing energy consumption for data transmission can be achieved by processing the data in a wireless node (data aggregation and data compression).

Usage of data compression in WSN nodes can significantly reduce the volume of data you want to transmit and thereby increase the lifetime of the network.

To improve the overall bandwidth methods of WSN multi-path routing and network coding are used.

It is shown in [2] that the use of field data packets with a maximum length leads to a significant reduction in the number of housekeeping data and thus to increase of total bandwidth WSNs.

Network encoding methods have begun to actively develop with the works of Ahlswede R. and others [3, 4]. The main problem in network encoding is choosing of method combination packages. A network encoding, currently developing, is based on two theoretical approaches: linear coding and the one based on Chinese Remainder Theorem [5-7].

The methods of linear network encoding leads to increase of housekeeping data in packets and therefore cannot be used in WSNs which are characterized by small size packages and have limited bandwidth communication channels [5].

In contrast to the methods of linear encoding network, encoding based on the Chinese Remainder Theorem allows to reduce the computational cost of data encoding and amount of ancillary data of protocols transmission [5-7].

The Benefits of Network Encoding in the residue number system for data transmission "one-to-many" is shown in [7]. In [5] usage of a set of relatively simple modules for encoding and transmission of messages based on Chinese Remainder Theorem on the example of multicast topology of the network "butterfly" has been suggested. However, this scheme is redundant for WSN, as there occurs duplication of residues in various routes leading to a decrease in bandwidth efficiency but energy efficiency increase. In WSN wireless nodes tend to transmit measured data to a base station that uses the principle of transmission of "many-to-one". The aim of research is to improve the efficiency of network encoding based on the residue number system for wireless sensor networks.

2. Network Encoding Based on the Residue Number System

Let us consider the example of network encoding based on the of network topology shown in Figure 1. Supposing you want to send messages X_1 and X_2 to node S.

Let us choose co prime modules p_1, p_2, p_3, p_4 . In node A divide message X_1 into modules p_1, p_2 : get $b_1 = X_1 \pmod{p_1}$, $b_2 = X_1 \pmod{p_2}$. In node B divide message X_2 into modules p_3, p_4 : get $b_3 = X_2 \pmod{p_3}$, $b_4 = X_2 \pmod{p_4}$. These residues transmit relevant routes (Fig. 1).

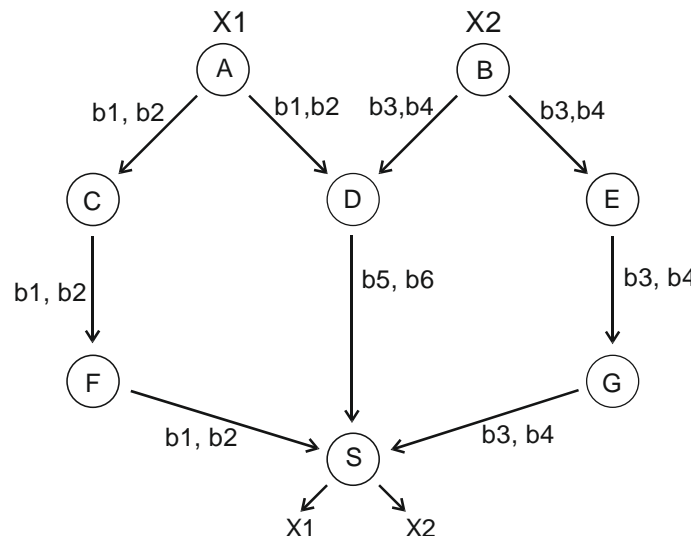

Fig. 1. Transmission residues with network encoding – scheme 1
 Rys. 1. Przesyłanie reszt z kodowaniem sieciowym – schemat 1

In the intermediate node *D* the union of residues *b1, b2, b3, b4* occurs by formula

$$X = \sum_i^n B_i \cdot b_i \pmod{R}, \tag{1}$$

where: $R = \prod_{i=1}^n p_i$, *n* – number of modules, *B_i* – basic number, $B_i = \delta_i \cdot m_i$,

$\delta_i = \frac{R}{p_i}$, $\delta_i \cdot m_i \equiv 1 \pmod{p_i}$, *m_i* – coefficient in the range $0 < m_i < p_i$,

and formation of new residues modulo *p2, p3*:

$$b5 = X \pmod{p2}, \quad b6 = X \pmod{p3},$$

or

$$b5 = X \pmod{p5},$$

where $p5 = p2 \cdot p3$.

To transmit messages *X1, X2* in the network (Fig. 1) it is necessary to transfer seven packets of data (Fig. 2).

Data packet consists of residues and modules and has the form:

$$\{b_1, b_2, \dots, b_i \dots b_n \mid p_i, p_{i+1}\}.$$

In node S the union of residues occurs by formula (1) and calculation of the values $X1 = X \pmod{p1 \cdot p2}$ and $X2 = X \pmod{p3 \cdot p4}$.

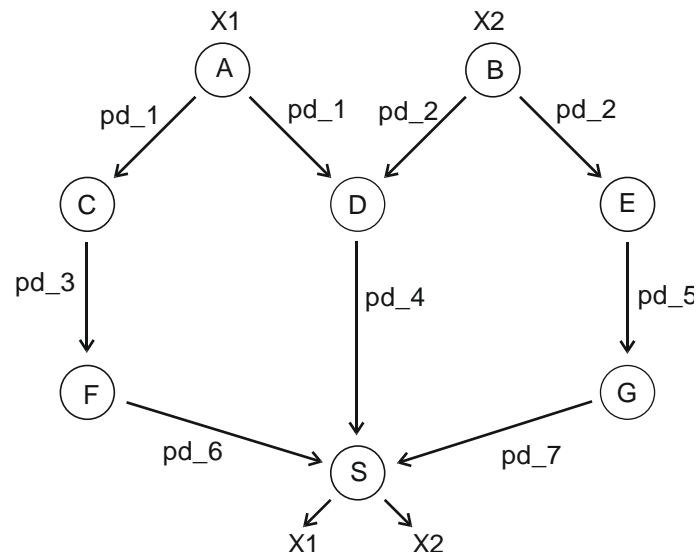

Fig. 2. Distribution of packets in the network encoding for – scheme 1
Rys. 2. Rozkład pakietów w kodowaniu sieciowym – schemat 1

This encoding scheme has advantages when multicast, however, is redundant for present topology, i.e. in transmission "many-to-one".

The author proposed a new method for network encoding in which the residues obtained $b1, b2$, in node A are transmitted via different routes. For example, the residue $b1$ is transmitted via route $A \rightarrow C$, accordingly residue $b2$ through via route $A \rightarrow D$. Similarly, the distribution of residues occurs in node B (Fig. 3).

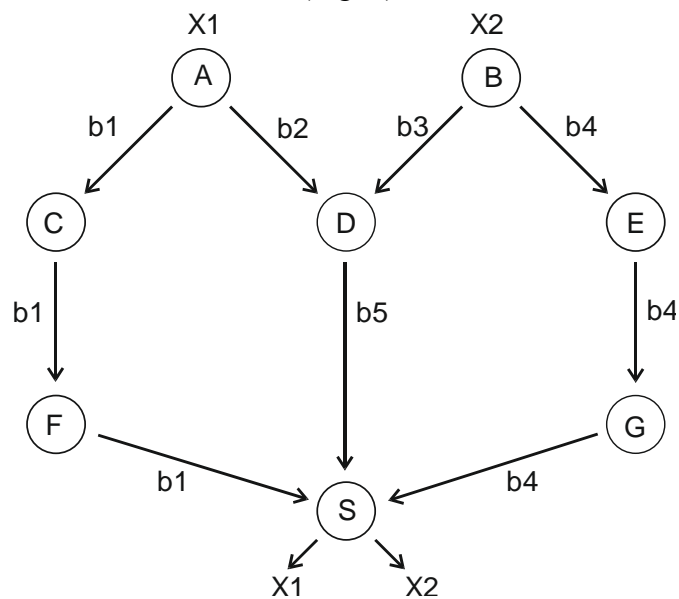

Fig. 3. Transmission of residues with network encoding – scheme 2
Rys. 3. Przesyłanie reszt z kodowaniem sieciowym – schemat 2

In the proposed distribution of residues for sending messages X_1 , X_2 to node S nine packages must be transferred (Fig. 4).

Despite the fact that the proposed method requires the transmission of more packets, the total amount of data to be transferred is less. Another advantage of this method is the ability to evenly distribute the load on the network. These co prime modules are chosen so that independent (separate) routes (A-C-F-S) and (B-E-G-S) (Fig. 3) transmitted the residues of larger amount and a joint route (D-S) transmits the ones of the smaller amount.

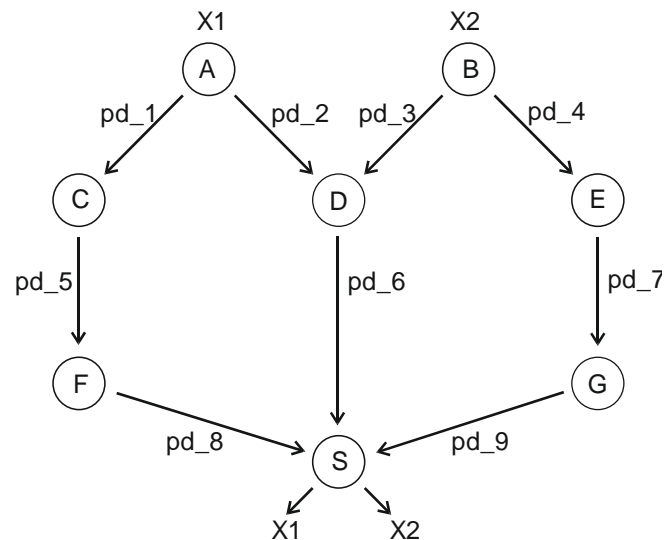

Fig. 4. Distribution of packets in the network encoding scheme for 2: pd_i – number of data packets
Rys. 4. Rozkład pakietów w kodowaniu sieciowym – schemat 2 pd_i – liczba pakietów danych

It is possible to reduce the number of packets similarly to scheme in Figure 2 by transmission via the first node simultaneously residues in two modules (Fig. 5), and the intermediate nodes rebroadcast only original residues (which have not been passed via the other routes).

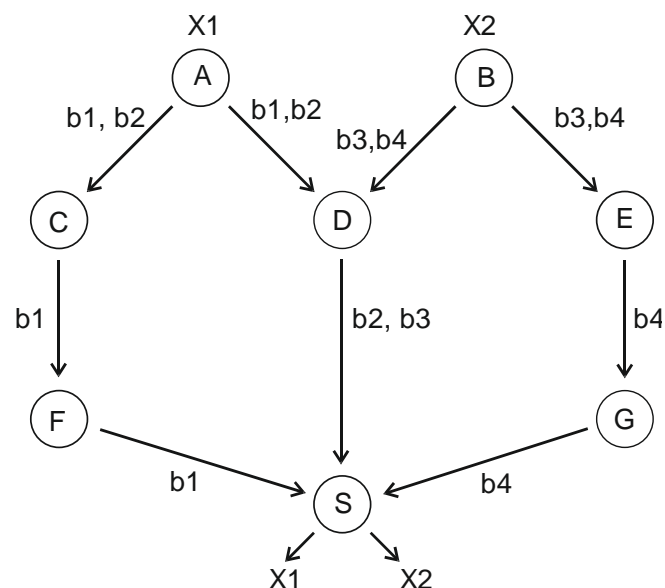

Fig. 5. Transmission residues with network coding – scheme 3
Rys. 5. Przesyłanie reszt z kodowaniem sieciowym – schemat 3

3. Calculating of Volume Data

We will evaluate the required amount of data at a fixed bit message for the investigated network coding schemes. Supposed the information source generates a message length of 32 bits.

Thus, the amount of data to be transferred based on retransmission packet is:

– for scheme 1 (Fig. 2):

$$V1 = k \cdot h \cdot \lceil \log_2 p_i \cdot p_{i+1} \rceil,$$

where, k – the number of messages; h – the number of packets required to transmit messages from node A, B to node S ;

– for scheme 2 (Fig. 3):

$$V2 = k \cdot h \cdot \lceil \log_2 p_i \rceil;$$

– for scheme 3 (Fig. 5):

$$V3 = k \cdot ((h - 3) \cdot \lceil \log_2 p_i \rceil + (h - 4) \cdot \lceil \log_2 p_i \cdot p_{i+1} \rceil)$$

As shown in Figure 6 the proposed network coding scheme (Fig. 5) to send messages to nodes A, B to station S requires transmission with taking into account the retransmission of packets by 50 % smaller amount of data compared to the scheme in Figure 2 and 25% smaller amount of data compared to the scheme in Figure 4.

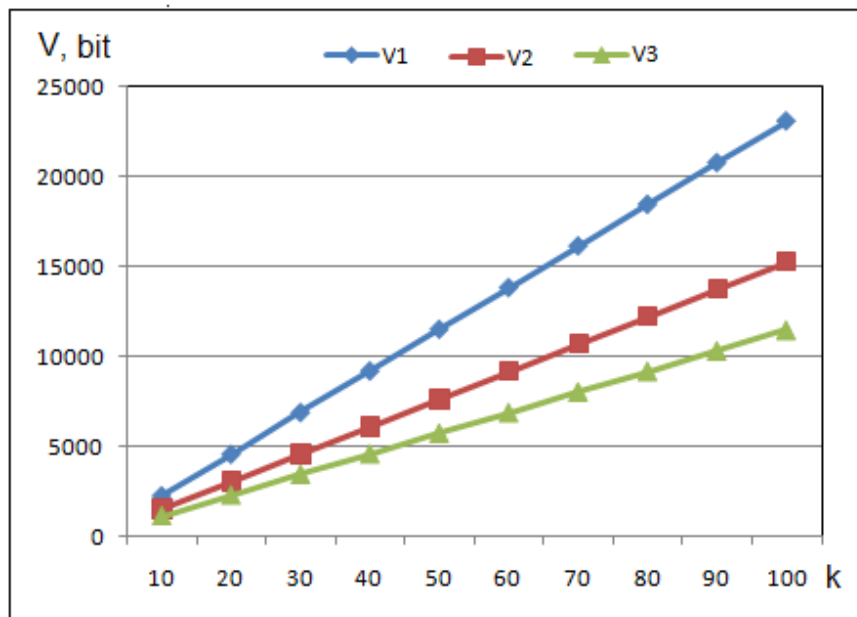

Fig. 6. Dependence of the amount of data on the number of messages in various encoding schemes: V1 – scheme Figure 2; V2 – scheme Figure 4; V3 – scheme Figure 5

Rys. 6. Zależność ilości danych od liczby wiadomości w różnych schematach kodowania: V1 – schemat rysunek 2; V2 – schemat rysunek 4; V3 – schemat rysunek 5

4. Estimation of the Total of Network Bandwidth

Let us consider wireless sensor network with $t = 50$ nodes. Transmission speed according to the standard IEEE 802.15.4 is 250 kbit/s. Let the information source generates integer X , where $\lceil \log_2 X_{\max} \rceil = 32$ bits, $\lceil \bullet \rceil$ – rounded off to a higher integer.

For each network node we will choose two modules from the coprime simple conditions $X_{\max} < p_i \cdot p_j$. Modules for one network node select different digit capacity $\lceil \log_2 p_i \rceil = 22$ bits and $\lceil \log_2 p_{i+1} \rceil = 11$ bits. The required number of modules equals $n = 2 \cdot t$. For example, a set of coprime modules for two nodes of the form [2106421, 2039], [2029, 2116799], for the first 10 nodes of the network.

The total network bandwidth we will calculate for network coding schemes (1-3) presented in Figures 1, 3 and 5.

Time message transfer for the coding scheme 1 (Fig. 1) is:

$$T_1 = t_{11} + t_{12} + t_{13} + t_{14} + t_{15}, \quad (2)$$

where: $t_{11} = \frac{\lceil \log_2 b1 \rceil + \lceil \log_2 b2 \rceil}{C}$ – time of transmission node A: (A → C, A → D); t_{12} – time of transmission node B: (B → D, B → E), $t_{12} = t_{11}$; t_{13} – time of transmission node C: (C → F), node D: (D → S), and node E: (E → G); t_{14} – time of transmission node F: (F → S); t_{15} – time of transmission node G: (G → S).

Considering that length of the message is the same, time of transmission messages is $T_1 = 5 \cdot t_{11}$.

Transmission time is calculated taking into consideration parallel packet transmission between nodes C → F, D → S, and E → G.

For the coding scheme in Figure 3 time of transmission messages is equal

$$T_2 = t_{21} + t_{22} + t_{23} + t_{24} + t_{25}, \quad (3)$$

where: $t_{21} = \frac{\lceil \log_2 b1 \rceil}{C}$ – time of transmission node A: (A → C) and B (B → D); $t_{22} = \frac{\lceil \log_2 b2 \rceil}{C}$ – time of transmission node A: (A → D), and B (B → E); $t_{23} = \frac{\lceil \log_2 b2 \rceil + \lceil \log_2 b3 \rceil}{C}$ – time of transmission node C: (C → F), D (D → S), and E (E → G); t_{24} – time of transmission node F: (F → S), $t_{24} = t_{21}$; t_{25} – time of transmission node G: (G → S), $t_{24} = t_{22}$.

Considering that packets between nodes $C \rightarrow F$, $D \rightarrow S$, and $E \rightarrow G$ are transmitted in parallel, therefore, t_{23} transmission time is larger than the packet size in the route ($D \rightarrow S$). For the coding scheme in Figure 5 time of transmission messages is equal:

$$T_3 = t_{31} + t_{32} + t_{33} + t_{34} + t_{35}, \quad (4)$$

where: $t_{31} = \frac{\lceil \log_2 b1 \rceil + \lceil \log_2 b2 \rceil}{C}$ – time of transmission node A: ($A \rightarrow C$, $A \rightarrow D$); t_{32} – time of transmission node B: ($B \rightarrow D$, $B \rightarrow E$); $t_{33} = \frac{\lceil \log_2 b2 \rceil + \lceil \log_2 b3 \rceil}{C}$ – time of transmission node C: ($C \rightarrow F$), D: ($D \rightarrow S$), and node E: ($E \rightarrow G$); $t_{34} = \frac{\lceil \log_2 b1 \rceil}{C}$ – time of transmission node F: ($F \rightarrow S$); $t_{35} = \frac{\lceil \log_2 b4 \rceil}{C}$ – time of transmission node G: ($G \rightarrow S$).

Considering that packets between nodes $C \rightarrow F$, $D \rightarrow S$, and $E \rightarrow G$ are transmitted in parallel, we take for t_{33} time of transmission packets in the route ($D \rightarrow S$).

The total capacity of the network, taking into account only the time of message transfer between the nodes for considered coding schemes is equal

$$C = \frac{V}{T} \text{ (bit/s),}$$

where: V – message volume; T – the overall time transmission messages with network coding and parallel of message transfer between nodes.

Having calculated the time transmission of messages formulas (2-4), dependency of the total network bandwidth on the message size 8 - 64 bits (Fig. 7) has been constructed.

As shown in Figure 7 the highest bandwidth (C21) provides a scheme in which residues are transmitted through separate routes with different modules of digit capacity. In that case the bit residues to be passed through the common route is approximately equal to the digit capacity residues in independent (separate) routes.

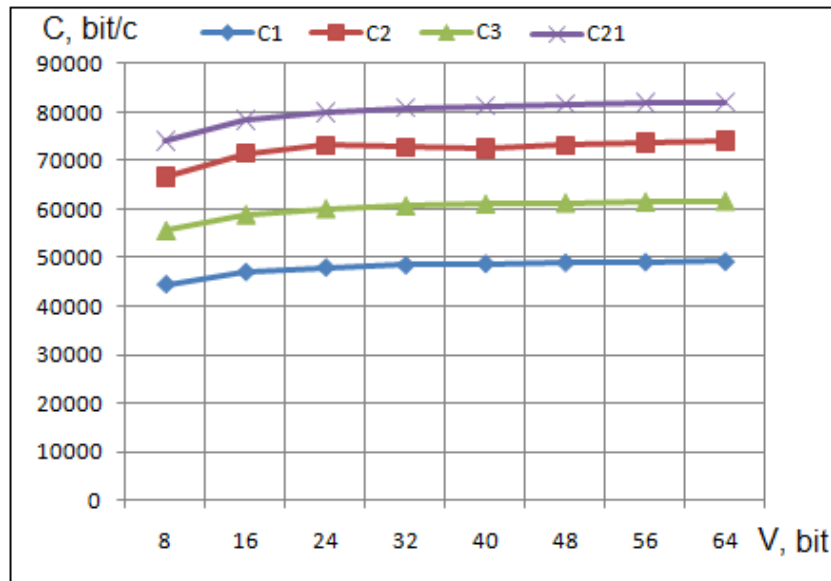

Fig. 7. The dependence of the total of network bandwidth on the size of messages for different network coding schemes: C1 – for the coding scheme shown in Figure 1; C2 – to the coding scheme shown in Figure 3; C3 – to the coding scheme shown in Figure 5; C21 – for coding scheme shown in Figure 3 in case of modules of different digit capacity

Rys. 7. Zależność przepustowości sieci od rozmiaru wiadomości dla różnych schematów kodowania sieci: C1 – dla schematu kodowania wg rysunku 1; C2 – dla schematu kodowania wg rysunku 3; C3 – dla schematu kodowania wg rysunku 5; C21 – dla schematu kodowania wg rysunku 3 w przypadku modułów o różnej pojemności

5. Conclusion

The method of network coding based on the residue number system would reduce the amount of data by 50%, taking into account retransmission of packets needed to recover messages. In the investigated method the modules are selected with different digit capacity so that the bit residues to be passed via through the common route is approximately equal to the digit capacity of residues in independent (separate) routes. This scheme of modules selection increases the overall network capacity by approximately 60%.

Bibliography

1. Perrig A. et al.: SPINS: Security protocols for sensor networks // Wireless networks. T. 8, No. 5, 2002, p. 521-534.
2. Yatskiv V.: Nonlinear data coding in wireless sensor networks/ Vasyl Yatskiv, Su Jun, Nataliya Yatskiv, Anatoly Sachenko // International Journal of Computing. – Vol. 10, Issue 4, 2011, p. 383-390.

3. Ahlswede R., Cai N., Li S.-Y.R., and Yeung R.W.: Network information flow, IEEE Transactions on Information Theory, Vol. 46, No. 4, 2000, p. 1204-1216.
4. Fragouli C., Le Boudec J.Y., Widmer J.: Network coding: an instant primer //ACM SIGCOMM Computer Communication Review. T. 36, No. 1, 2006, p. 63-68.
5. Zhang Zhifang.: Network Coding Based on Chinese Remainder Theorem. arXiv preprint arXiv:1208.3966, 2012.
6. Campobello G., Leonardi A., Palazzo S.: Energy Saving and Reliability in Wireless Sensor Networks Using a CRT-based Packet Splitting Algorithm // University of Messina, Italy, 2010.
7. Yatskiv V., Su Jun.: The network coding based on residue number system in wireless sensor networks // Proceedings of International Conference on Information Technology and Management Engineering ITME2011, Wuhan, China 2011, p. 27-30.

Omówienie

Sposób kodowania sieci opartej na systemie liczbowym zmniejsza ilość potrzebnych danych o 50%; biorąc pod uwagę kwestie retransmisji pakietów, niezbędne do odzyskania wiadomości. W badanej metodzie moduły są wybrane tak, że reszty bitów, które mają być przekazywane za pośrednictwem wspólnej trasy są w przybliżeniu równe przepustowości cyfrowym pozostałościom. Taki schemat doboru modułów zwiększa całkowitą pojemność sieci o około 60%.