

2643/110  
13  
THE BELL SYSTEM

BIBLIOTEKA  
POLITECHNICZNEJ  
SLASKIEJ  
P.25/53

# Technical Journal

DEVOTED TO THE SCIENTIFIC AND ENGINEERING  
ASPECTS OF ELECTRICAL COMMUNICATION

---

VOLUME XXXII

JULY 1953

NUMBER 4

---

## THE L3 COAXIAL SYSTEM

- BIBLIOTEKA  
POLITECHNICZNEJ  
SLASKIEJ
- Foreword 779
- System Design  
C. H. ELMENDORF, R. D. EHBAR, R. H. KLIE AND A. J. GROSSMAN 781
- Equalization and Regulation  
R. W. KETCHLEDGE AND T. R. FINCH 833
- Amplifiers L. H. MORRIS, G. H. LOVELL AND F. R. DICKINSON 879
- Television Terminals J. W. RIEKE AND R. S. GRAHAM 915
- Quality Control Requirements  
H. F. DODGE, B. J. KINSBURG AND M. K. KRUGER 943
- Application of Quality Control Requirements in the Manufacture  
of Components  
R. F. GARRETT, T. L. TUFFNELL AND R. A. WADDELL 969

- 
- Abstracts of Bell System Technical Papers Not Published in this  
Journal 1007
- Contributors to this Issue 1015
-



# THE BELL SYSTEM TECHNICAL JOURNAL

## ADVISORY BOARD

S. BRACKEN, *President, Western Electric Company*

F. R. KAPPEL, *Vice President, American Telephone  
and Telegraph Company*

M. J. KELLY, *President, Bell Telephone Laboratories*

## EDITORIAL COMMITTEE

E. I. GREEN, *Chairman*

A. J. BUSCH

F. R. LACK

W. H. DOHERTY

J. W. MCRAE

G. D. EDWARDS

W. H. NUNN

J. B. FISK

H. I. ROMNES

R. K. HONAMAN

H. V. SCHMIDT

## EDITORIAL STAFF

J. D. TEBO, *Editor*

M. E. STRIEBY, *Managing Editor*

R. L. SHEPHERD, *Production Editor*

THE BELL SYSTEM TECHNICAL JOURNAL is published six times a year by the American Telephone and Telegraph Company, 195 Broadway, New York 7, N. Y. Cleo F. Craig, President; S. Whitney Landon, Secretary; Alexander L. Stott, Treasurer. Subscriptions are accepted at \$3.00 per year. Single copies are 75 cents each. The foreign postage is 65 cents per year or 11 cents per copy. Printed in U. S. A.



# THE BELL SYSTEM TECHNICAL JOURNAL

VOLUME XXXII

JULY 1953

NUMBER 4

*Copyright, 1953, American Telephone and Telegraph Company*

## The L3 Coaxial System

### Foreword



The articles in this issue are devoted to different phases of the development of a new system for the transmission and utilization of broader frequency bands on existing or new coaxial cables. This new system, which is called the L3 carrier system, represents the latest phase of development activities begun in the late twenties. It permits far more intensive exploitation of the cable medium than its predecessor, affording the option of providing, in each direction on a pair of coaxial tubes, either 1860 telephone channels or 600 telephone channels and a 4.2 megacycle broadcast television channel.

These results have been attained through wide extension of previous art. New electron tubes, transformers, inductors, and other circuit elements have been designed for extreme precision in respect to stability and other performance factors. Statistical quality control techniques are being applied to obtain the benefits of closely controlled distribution of the performance of circuit elements and system units. Fundamental to the program has been the devising of techniques for achieving hitherto unobtainable accuracies in the measurement of impedance, loss, phase and other transmission properties. To provide precise attenuation and delay characteristics over the wide frequency band, new techniques of network synthesis have been developed.

Refined system analysis and circuit design have derived maximum performance from component capabilities. The highest standards of



overall transmission performance and reliability have been adhered to. The new system is now in commercial service and large scale application is planned.

The following articles discuss (1) the over-all systems, together with its fundamental design problems, (2) the methods developed for equalization and regulation, (3) the broadband amplifying techniques, (4) the circuits for transmitting and receiving television, (5) the requirements established for controlling the performance of component elements, and (6) the application of these requirements in manufacturing.

E. I. GREEN



# The L3 Coaxial System

## System Design

By C. H. ELMENDORF, R. D. EHRBAR, R.H. KLIE, and  
A. J. GROSSMAN

(Manuscript received March 31, 1953)

*The L3 coaxial system is a new broadband facility for use with existing and new coaxial cables. It makes possible the transmission of 1,860 telephone channels or 600 telephone channels and a television channel in each direction on a pair of coaxial tubes. The principal system design problems and the methods used in their solution are described. The over-all system is described in terms of its components and their location in the system.*

### 1.0 INTRODUCTION

The L3 coaxial carrier system is a new broadband transmission system capable of transmitting either 1,860 telephone message channels or 600 message channels and a 4.2-megacycle broadcast television channel, in each direction, on a pair of coaxials. The system is designed so that signals transmitted over any of these channels will meet high quality Bell System objectives after 4,000 miles of transmission.

The system is composed of auxiliary or line repeaters spaced at approximately four-mile intervals along the cable route and connecting terminal or dropping repeaters where telephone or television signals are translated to or from the L3 frequency band. Equalization equipment, power generating and power transmission equipment, and maintenance equipment are required at 100 to 200-mile intervals.

Planning and exploratory development for the system was started late in 1945 with the objective of designing a trunk route system which would provide the maximum channel capacity on the existing coaxial cable consistent with the state of the repeater art. At that time and for the next four years a large amount of new cable employing the 600 channel-three megacycle L1 coaxial carrier system was being installed or projected.<sup>1</sup>

Since a major field of use of the L3 system was to replace the L1



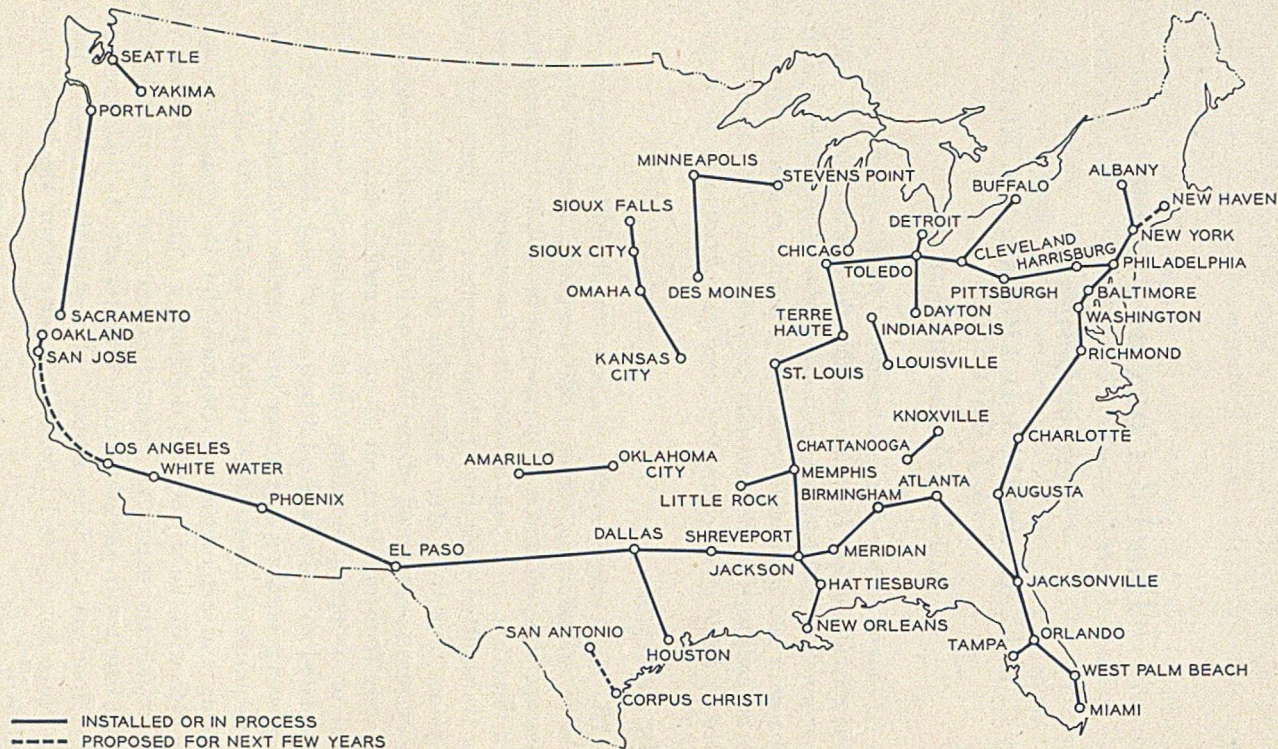

Fig. 1 — Coaxial cable routes.



system on existing routes, the design of the L1 system, the cable, and the cable route layouts presented the L3 system with a definite plant framework. The present day network of L1 coaxial systems is shown in Fig. 1. There are about 8,000 route miles of cable installed of which about 70 per cent consists of eight coaxials, the remainder consisting of six and four coaxials. About 70 per cent of this cable uses coaxials with a  $\frac{3}{8}$ " diameter outer conductor, the present day standard. The remainder uses the older 0.27" diameter coaxials. All but a few miles of this cable is plowed into the ground or placed in underground conduit. A piece of a typical eight coaxial cable is shown in Fig. 2. Normally, the coaxials are included in a lead sheath with interstitial pairs which are used for

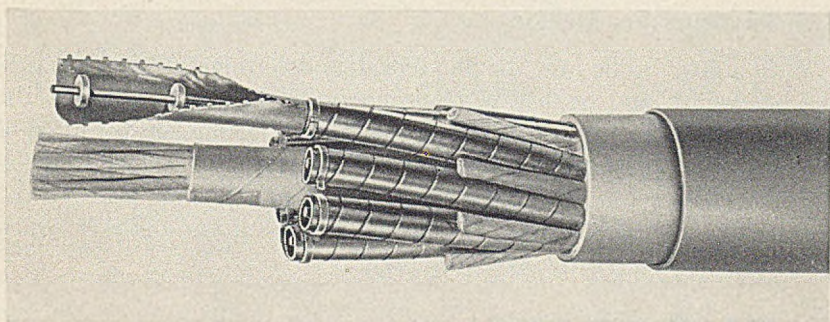

Fig. 2 — An 8-coaxial cable.

control purposes. In many cases additional quads are included in the cable for other types of transmission systems.

The broad objectives of the L3 system planning were:

1. The existing cable was to be reused. Thus, the cable loss and its variation with temperature, the cable irregularities due to manufacturing and splicing, and the power transmission capabilities of the cable became basic restrictions on the design of the L3 system.

2. The L1 telephone terminal equipment was to be reused. This equipment involves channel banks, group and super-group equipment and carrier supplies.<sup>2</sup> This limited the system planning to the use of frequency division multiplex on a single sideband carrier suppressed basis.

3. It would be desirable to reuse existing L1 repeater locations and buildings. The L1 auxiliary repeaters are spaced at eight mile intervals and housed in 6' x 9' concrete block huts. The L1 main repeaters are spaced at 40 to 160-mile intervals largely dictated by geographical and power transmission considerations.



4. Sufficient bandwidth should be provided so that a black and white television signal of at least four-megacycle quality could be transmitted simultaneously with 600-message signals, the message capacity of the L1 system. Alternatively, as many message channels as possible should be transmitted when there was no need for television service.

5. The channels should meet Bell System high quality signal-to-noise and equalization objectives after 4,000 miles of transmission.

Section 2 of the paper is devoted to a discussion of the principal system design problems and descriptions of methods used in solving these problems. Section 3 contains descriptions of the components of the system, their locations and their functions.

## 2.0 TRANSMISSION DESIGN

With a given cable loss, the line repeaters determine in large measure the bandwidth and quality of transmission and the economics of the system. The basic system plan therefore evolves from a consideration of the signal-to-noise and equalization performance — i.e., the transmission stability — that can be designed into the repeaters. This leads to the development of broad signal-to-noise and equalization analyses which guide and coordinate the system design.

### 2.1 SIGNAL-TO-NOISE DESIGN

Simply stated, the signal-to-noise problem is to adjust the repeater spacing and bandwidth of the system so that channel objectives can be met with the repeater noise, linearity, and gain performance that the electron tube and circuit art permit. In detail this means the following: (1) to translate the broad transmission objectives on message and television channels into detailed requirements on noise, specific modulation products and compression; (2) analyzing the amount of these interferences that result from various repeater design choices; (3) determining the effect of signal wave form and frequency allocations on both the channel requirements and the repeater performance; and (4) integrating these studies into a specific system design plan that meets the objectives.

#### 2.11 *Telephone Channel Interference Objectives*

The amount of noise, tone interferences or crosstalk that is considered tolerable in telephone channels is generally determined by judgments involving the subjective reactions of representative observers to specific interferences on typical transmitted signals and by the cost of providing a given grade of service. The broad objectives for message



channels stem from early unpublished work on transmission standards. The interference and load capacity requirements for transmission systems involving large numbers of message channels were developed by Dixon, Holbrook and Bennett.<sup>3, 4</sup> In effect, they provide techniques for translating channel objectives into linearity and power handling requirements on repeaters, taking into account the statistical properties of individual and multi-channel speech. Based on the data and techniques in these papers, the requirements on individual channels shown in Table I can be derived. These requirements in themselves form an important basis for the signal-to-noise design of the system. However, in a highly refined system design it is necessary to extend our notions of requirements somewhat further.

In the L3 signal-to-noise design the message channel requirements of Table I were used as the initial basis for study. However, when specific interferences of a complex nature were found to be limiting, the wave forms and the probability of their occurrence were examined in detail. As a result of these studies, two distinctive types of interferences were found to be important when the system is used to carry message and television signals simultaneously. The first of these, due to both second and third order modulation involving multifrequency key pulse signals and components of the television signal, has the characteristics of intermittent musical tones. The second, due to the second order difference products generated by the television signal components, produces tones in the message channels which vary in amplitude and frequency as the television signal changes with picture content. Both types of interference were generated in the laboratory and recorded on tapes. From these tapes, records were cut and then used in a series of subjective tests

TABLE I — SUMMARY OF MESSAGE CIRCUIT OBJECTIVES  
(Allowable Zero Level Interference in 3 kc band)

Source of Interference	Type of Interference	dba (message Weighting)	dbm* Unweighted
Terminals.....	Largely spillover between channels, cross-modulation, and crosstalk	+32	-50†
Line .....	Noise and multichannel modulation	+36	-46†
Line .....	Unintelligible crosstalk and babble	+24	-53†
Line .....	Tones	+24	-61‡
Total .....	All sources	+38	-44†

\* The translations from dba to dbm are effected by noting that a 3000 cycle band of flat noise with one milliwatt of power equals +82 dba and that one milliwatt of 1000 cycle single frequency is equal to +85 dba.

† Interference assumed evenly distributed over 3000 cycle band.

‡ Tones assumed to be at 1000 cycles.

which were made to determine the maximum permissible magnitudes consistent with other important message circuit objectives.

### 2.12 *Television Channel Interference Objectives*

The amount of noise and single-frequency interference that can be tolerated in a commercial grade television channel again depends on judgements involving the subjective reactions of observers and the cost of providing a given grade of service. The broad objectives are based on subjective measurements which have been reported on by Messrs. Mertz and Baldwin.<sup>5, 6, 7</sup> From this work it has been determined that 95 per cent of the observers consider a signal-to-noise ratio of 40 db (composite signal to rms noise) tolerable, providing the noise has a frequency characteristic that rises about 11 db across the video band. Likewise the tolerable single frequency interference can be set at -70 db (peak sine wave below composite signal) if the interference falls below about one megacycle. The requirement becomes more lenient for interferences falling in the upper part of the band.

Again, for a refined system design, more detailed account must again be taken of the requirements on short duration interferences, the probability of interference occurring, and the exact frequency in the television spectrum that an interference occurs.

In the L3 signal-to-noise design the broad television channel objectives outlined above were used except when a specific complex interference was found to be limiting. For complex interferences, three additional types of requirement data were used; (1) tests were made to determine visual thresholds relative to steady tones of short bursts of energy such as occur in the television channel due to switchhook "bang-up" and multifrequency key pulsing signals in the message channels. Fig. 3 shows the relation between the steady state and transient requirement; (2) advantage was taken from the fact that interferences falling between the 15.75-kc line scan multiples of the television signal would be less interfering than unwanted energy falling directly at the line scan multiples; and (3) a judgement was used that the tolerability of an interference depends on its probability of occurrence. The judgement was not made on a quantitative basis but when an interference was found to exceed its requirement by a few db two or three times a day it was ignored in the signal-to-noise design.

### 2.13 *Frequency Allocations*

The final frequency allocations shown in Fig. 4 are a result of the signal-to-noise design. The principal features were determined on rather



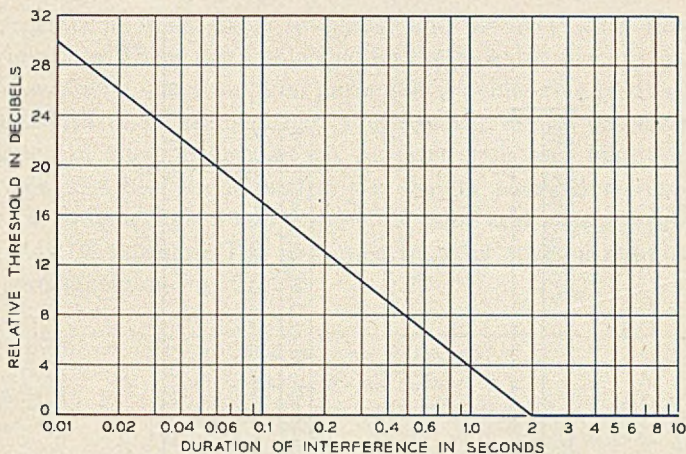

Fig. 3 — Television bar pattern threshold versus duration.

general grounds. When the system is arranged for combined television-message transmission, the television channel is placed above the message channels so that the second harmonic of the television carrier and its immediately adjacent side bands will fall at the top edge of the band where the requirement is more lenient. Likewise, the line repeater noise tends to rise with frequency as does the amount of noise that the television channel can tolerate. Details of the frequency allocations shown on Fig. 4 will be discussed in later sections.

Pilot frequencies, indicated on Fig. 4, are transmitted to control the transmission characteristic of the system as described in a companion paper.<sup>10</sup> The frequencies, and the power at which the tones are transmitted, were selected on two bases; (1) where possible, frequencies used for similar purposes in the L1 system were selected for possible economies in pilot supply design and manufacture; these are the 556, 2,064 and 3,096-ke pilots; and (2) the transmission of these pilots should not materially degrade the signal-to-noise or load capacity performance of the system. The latter requirement led to a careful study of cross-modulation products involving the pilot frequencies to assure that message and television objectives would be met.

#### 2.14 Repeater Performance

The details of the amplifier design and the factors which determine its performance are covered in a companion paper.<sup>8</sup> For purposes of the signal-to-noise design it is sufficient to know the noise power vs frequency characteristic, the second and third order modulation coefficients

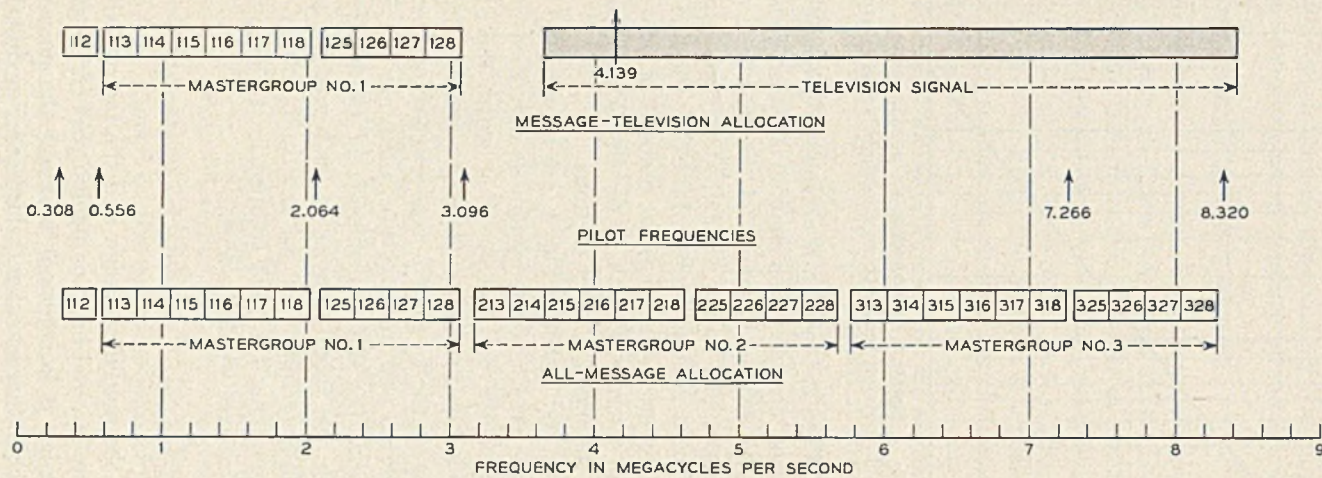

Fig. 4 — L3 frequency allocations.



of the repeater as functions of frequency and the overload performance of the repeaters. These factors depend on the repeater spacing and cable loss characteristic, electron tube parameters, achievable feedback, and the bandwidth to be transmitted. Thus, in the design procedures the dependence of these properties on repeater gain and bandwidth are determined and used in adjusting the system parameters for a final compatible design. Figs. 5 and 6 show the noise and linearity properties of the final L3 repeater. The four mile repeater spacing requires a repeater gain shown on Fig. 7.

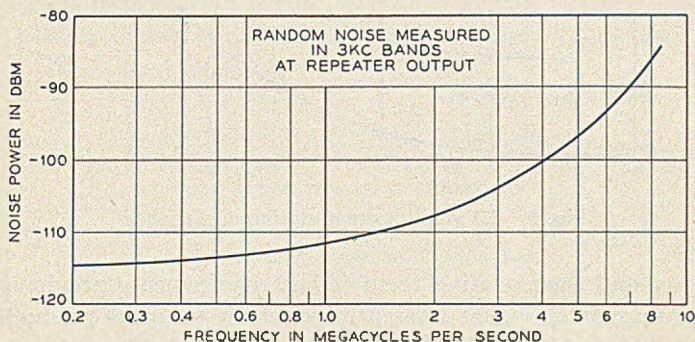

Fig. 5 — L3 Auxiliary repeater noise characteristic.

## 2.15 SIGNAL MECHANISMS

A signal-to-noise plan which contemplates transmitting the complex wave form of the combined telephone and television channels through 1,000 auxiliary amplifiers and about 200 flat amplifiers with performance factors that are variable with frequency will depend very strongly on the detailed analysis of the interactions between the signals and the repeater system characteristics. In developing this aspect of the signal-to-noise design four related phenomena had to be examined in detail.

### 2.151 *Intermodulation Between Signals in Different Parts of the Band*

In the classical multichannel modulation theory for a large number of message channels, the modulation noise generated by interaction of the speech signals due to the non linear characteristics of the amplifier is shown to be equivalent in interfering effect to random noise. In addition to this type of interference in message channels, cross modulation between components of the message and television signals result in a host of specific individual modulation products which have been examined by determining their amplitude, duration and probability of



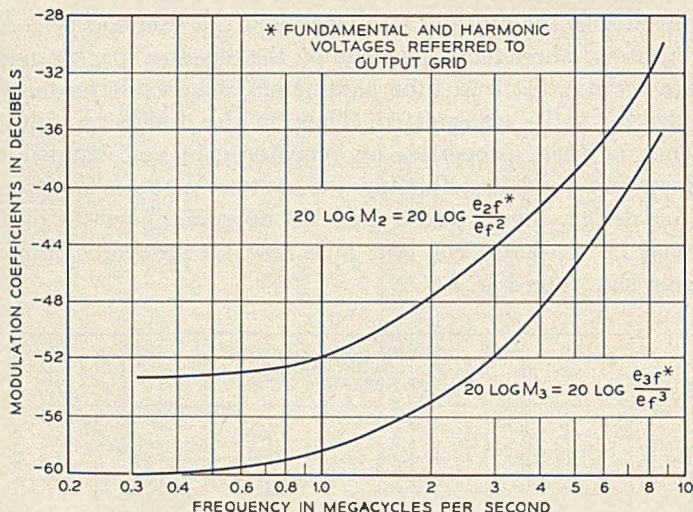

Fig. 6—L3 amplifier modulation coefficients.

occurrence and then relating them to the requirements previously discussed. Approximately 400 different products or groups of products were studied in the design of the L3 system. All but about thirty of these were found to be of negligible importance for the signal levels and frequency allocations being given serious consideration. On final analysis six of these thirty products were found to be controlling in establishing system levels. Fig. 8 shows the generating signals and the products they form for the six most critical products. The exact way in which the critical pro-

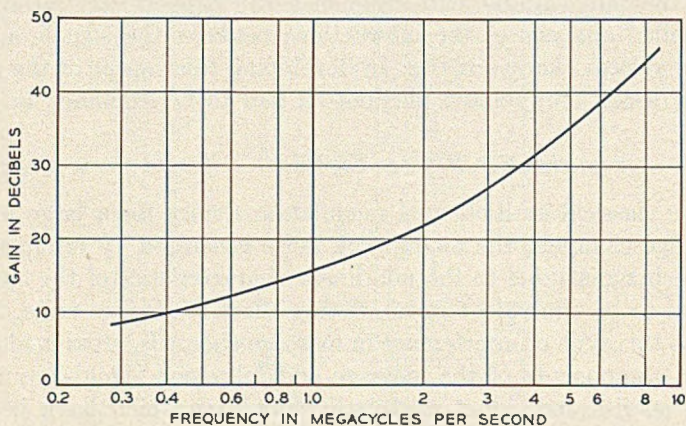

Fig. 7—L3 repeater gain characteristic.



ducts entered into the determination of signal levels and frequency allocation will be discussed later.

### 2.152 Location of the Television Carrier Relative to the Telephone Channel Carriers

Among the important modulation product types is one formed by difference frequencies involving components of the telephone and television signals, see Fig. 8(d). These interferences fall back into the telephone band and are of different magnitudes depending, among other things, on which components of the television signal produce them; those

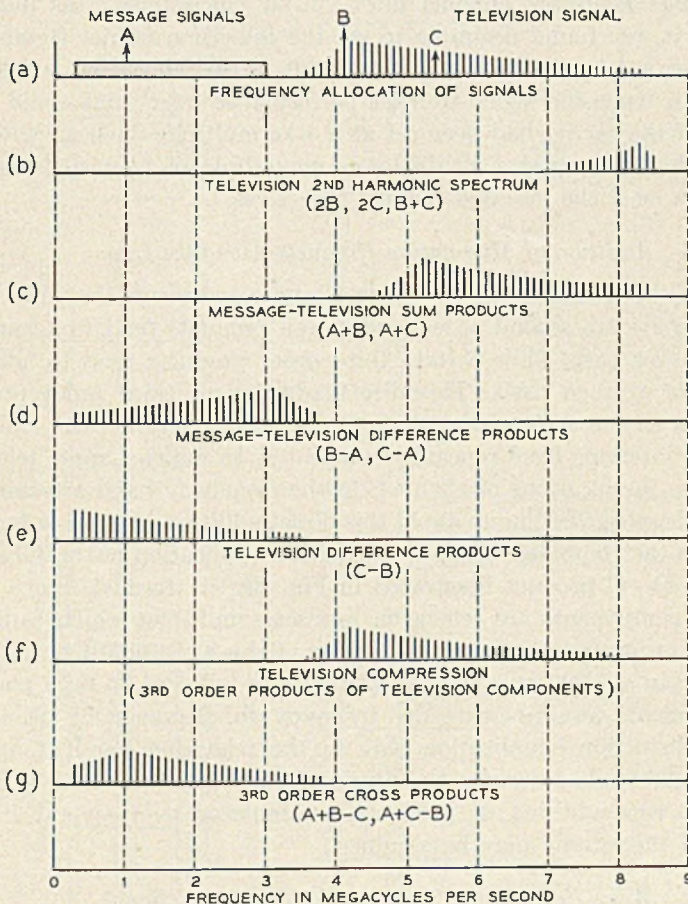

Fig. 8. — L3 coaxial system. Critical modulation products in combined message-television application.



produced by the television carrier and adjacent line scan multiples are by far the strongest.

The energy in a disturbing telephone channel tends to be concentrated near the 1,000-cycle point in the voice frequency band. By careful choice of the television carrier frequency, the difference products produced by cross modulation between telephone signals and the high magnitude television signal components can be made to fall at frequencies such that the high energy portions of these products are greatly attenuated by the cut-off characteristics of channel filters.

The message channels are spaced at 4-ke intervals controlled by carrier frequencies which are multiples of 4 ke. To obtain the maximum advantage from the channel filter cut-off characteristic as described above, it was found desirable to set the television carrier frequency 1 ke below a 4-ke multiple. A direct result of this allocation is a gain of 12 db in television signal-to-noise performance over what could be realized if the carrier had been set at a 4-ke multiple. Such an allocation would have required a 12 db lower magnitude of television signal in order to meet the message channel objectives.

#### 2.153 *Addition of Modulation Products Along the Line*

It has been established by analysis and experiment, that in a multi-repeater system second order modulation products tend to accumulate on a power basis while certain third order products tend to add on a direct or voltage basis. This direct addition of third order products depends on the slope of the phase curve being the same over small frequency intervals from repeater to repeater. In multi-channel telephone systems, the locations of channels in the frequency band are shifted at intervals along the line to avoid this direct addition of third order products. In the combined telephone-television application of the L3 system the A+B-C product illustrated in Fig. 8(g) is formed. Since the B and C components are television line scan multiples which cannot be shifted in location, certain components of this type product would add directly in a 4,000-mile system. If this were allowed to take place the requirements would be exceeded by many db. However, by placing the delay distortion equalization only in the television band at approximately 200-mile intervals the phase of these products can be shifted so that rms addition of products accumulated over several 200-mile links of the system may be assumed.

#### 2.154 *Wave Form of the Transmitted Television Signal*

Early studies of L3 led to the conclusion that the most economical method of transmitting the television signal would be by amplitude



modulation of a carrier with one sideband partially suppressed, i.e., vestigial sideband transmission. There remained, however, three major problems for detailed study; (1) the transmission of dc components of the video signal; (2) the per cent modulation of the carrier which for convenience is defined in terms of "excess carrier ratio", the ratio of the peak (white) signal to the peak-to-peak composite signal as measured in the carrier frequency envelope; and (3) the sign or sense of modulation, that is, whether increasing or decreasing brightness should correspond to increasing signal voltage on the high frequency line. Typical waveforms illustrating the alternatives are shown in Fig. 9.

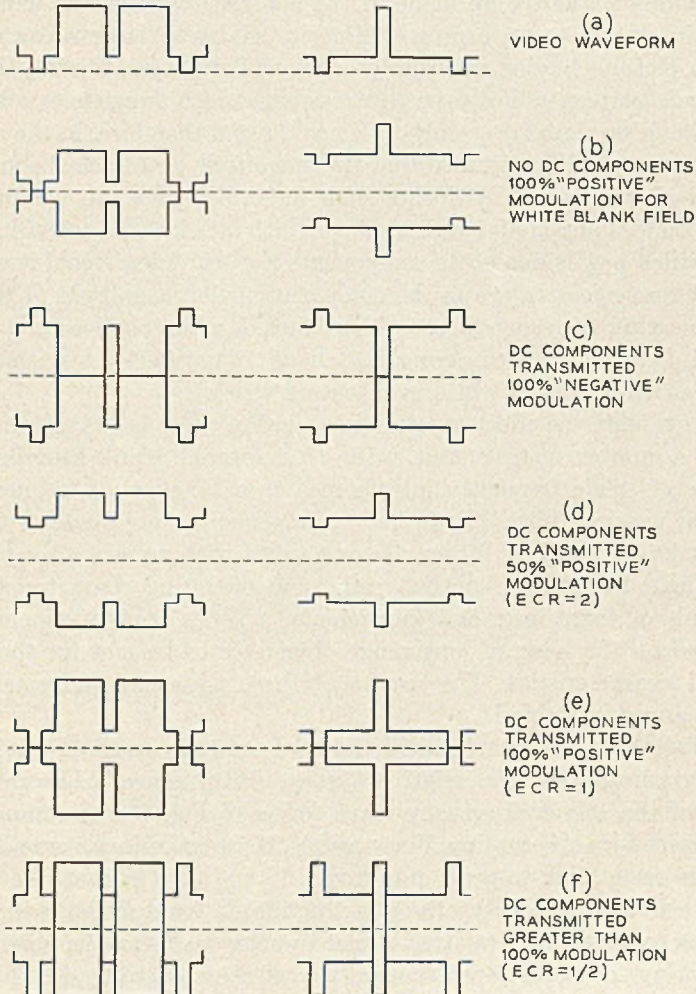

Fig. 9 — Typical television signals. Alternative carrier frequency waveforms.



The solution to each of these problems required an understanding of how the various alternatives would be affected by the system noise and linearity performance and an understanding of representative television viewing tube performance with respect to susceptibility to different types of interference. In analyzing the effect of system performance on these problems, it was found that non-linearity (cross modulation) would produce interferences in the television band which, while very complex electrically because of the effect of cross modulation involving line scan components of the signal, would produce the same effect on viewing tubes as single frequency interferences, i.e., bar patterns. Further simplifications were made in the analysis when it was found that such interferences were most visible in relatively large areas of television pictures having essentially constant brightness. During the time intervals corresponding to such areas, the video frequency voltage of the television signal is essentially constant and therefore, in the cases of interest, it could be assumed that the magnitude of the television carrier would also be constant during such intervals. Thus, to compute the magnitude of any modulation product which falls into the television band and which has as one of its components the television signal itself, it is found convenient to use in the computation the magnitude of the television carrier corresponding to either black or white portions of a picture signal. (The reason for intermediate shades of gray being less susceptible than either black or white is discussed below).

To evaluate the effect of television viewing tubes on wave-form problems, a number of tests were made to determine blank field threshold values of single frequency interference as a function of frequency for typical viewing tubes. Furthermore, judgements were made as to what might be expected of future viewing tubes with respect to achievable high light brightness, contrast ratio, and operating characteristics. As a result of these tests and judgements, a series of requirements were derived on the basis of long range objectives to be met for these projected characteristics. The results of these tests and judgements are summarized in Table II.

Using the parameters and methods of analysis outlined in the preceding paragraphs, the relative system performance achievable with each of the carrier frequency wave forms of Fig. 9 was computed or determined by observation. For example, these wave forms are all drawn to the same peak-to-peak amplitude. If we assume that the coaxial system is limited only by the peak amplitude transmitted we may use Fig. 9 to determine relative signal-to-noise performance directly by measuring the peak-to-peak magnitude of the composite signal voltage (sync tip to white) transmitted.



Fig. 9 may also be used to obtain relative modulation performance. For this purpose, the following factors must be considered; (1) the magnitude of the signal generating the interference ("black" or "white" carrier magnitude); (2) whether the interference is proportional directly or to the square of the carrier magnitude; (3) relative interference sensitivity in black or white portions of the picture; and (4) deviations from the Weber-Fechner law as the brightness is varied over its full range. The relationships among these factors were used to establish that for all cases of interest, bar patterns due to cross modulation are always more interfering in either black or white portions of a picture than in an intermediate gray area.

Table III shows the relative system performance for the five carrier frequency wave forms of Fig. 9. For comparison purposes, the signal-to-noise and signal-to-bar pattern ratios are all related to Fig. 9(f).

TABLE II — TELEVISION VIEWING TUBE CHARACTERISTICS ASSUMED FOR L3 SIGNAL-TO-NOISE ANALYSES

1. Brightness-grid voltage characteristic of viewing tubes follows 5/2 power law:  
 $B \propto e_g^{5/2}$ .
2. Maximum high light brightness of viewing tubes will be 150 foot lamberts.
3. Contrast ratio of viewing tubes will be 150:1.
4. Viewing tubes will have interference sensitivities which vary with brightness in accordance with the characteristic of Fig. 10.
5. The visibility of bar patterns will decrease with frequency in accordance with the characteristic of Fig. 11.
6. Deviations from the Weber-Fechner law may be assumed to follow the curve of Fig. 12. This law states that "the minimum change in stimulus necessary to produce a perceptible change in response is proportional to the stimulus already existing."

It is obvious from Table III that the signal is transmitted most efficiently at an excess carrier ratio of one half. The wave form of Fig. 9 (f), which illustrates excess carrier of one half, is the one used in L3. Television terminal circuit problems arising from this choice of carrier frequency wave form are discussed in another paper.<sup>9</sup>

### 2.16 *Signal Levels and Repeater Spacing*

In a broadband system like L3, the problem of determining the repeater spacing is made complex by the large number of parameters that must be considered. The approach to this problem that has been used to advantage in the L3 design is to assume several reasonable values of repeater spacing and determine for each the system performance achievable with various combinations of important parameter values. This method also permits evaluation of the effects on repeater spacing due to variations in parameters so that it is possible to form judgements as to the most economic design.



TABLE III — RELATIVE PERFORMANCE OF ALTERNATIVE TELEVISION WAVEFORMS

Waveform*	Relative Signal-to-Noise Ratio in db†	Relative Signal-to-Modulation Ratio (Bar Patterns) in DB‡	
		Group 1	Group 2
9b no dc . . . . .	+10.2	+11	+11.3
9c neg. mod. . . . .	+6	+9.5	+12.5
9d ECR = 2 . . . . .	+12	+14	+15.5
9e ECR = 1 . . . . .	+6	0	+6
9f ECR = 1/2 . . . . .	0	0	0

\* The waveforms are numbered to correspond to those given on Fig. 9.

† All values referred to E.C.R. =  $\frac{1}{2}$ ; plus values indicate poorer performance.

‡ All values referred to E.C.R. =  $\frac{1}{2}$ ; Group 1 products are those whose magnitudes are directly proportional to the carrier magnitude. Group 2 products are those whose magnitudes are proportional to the square of the carrier magnitude.

One of the important factors in setting repeater spacing is the magnitudes at which signals are transmitted in the system and the relation between these magnitudes and signal-to-noise and repeater overload performance. In the all telephone system (1,860 channels), the telephone levels (db with respect to the transmitting toll test board) were set to optimize signal-to-noise performance. To avoid penalizing the channels in the upper part of the band where random noise tends to be much higher than at low frequencies, the levels of the three mastergroups are staggered. At the output of any repeater in the high frequency line, the nominal level of mastergroup No. 1 is  $-21$  db, that of mastergroup

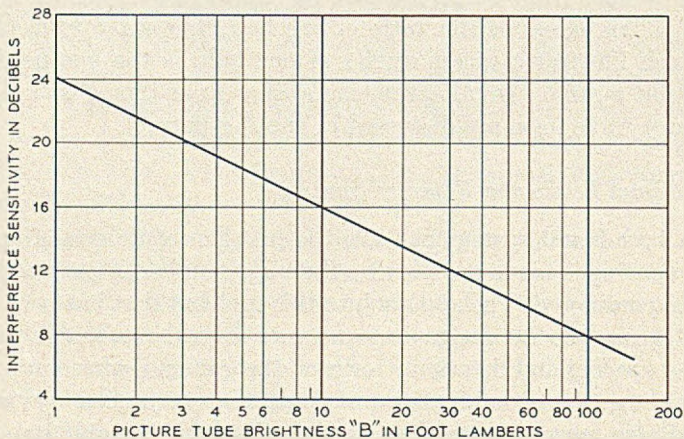

Fig. 10 — Picture tube interference sensitivity assumed for L3.



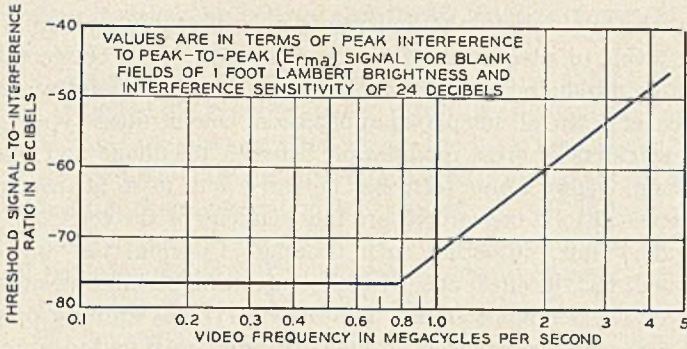

Fig. 11 — Threshold values for bar patterns.

No. 2 is  $-16$  db and that of mastergroup No. 3 is  $-11$  db. As a consequence of setting levels in this way, the random noise in the message channels is approximately 2 db higher on the average than modulation noise. It can be shown that with both second and third order modulation products contributing, and with third order somewhat predominant, this relation between random noise and modulation noise produces optimum signal-to-noise performance. With these levels, the 1,860 channel telephone system has approximately 6 db margin against repeater overload which, for L3 purposes, has been defined as the point at which the repeater modulation coefficients just depart from their constant small-signal values. The signal-to-noise objective of  $+29$  dba at the  $-9$  db level is met with about 2 db margin.

When the system is used to transmit television and message signals simultaneously, the level of the telephone channels in mastergroup No. 1 at the repeater output is the same as that of mastergroup No. 1 in the all-telephone application,  $-21$  db. The most convenient measure of the television signal is the power of the unmodulated carrier at the output of a repeater. Its value is  $+6$  dbm. Due to the inter-relations

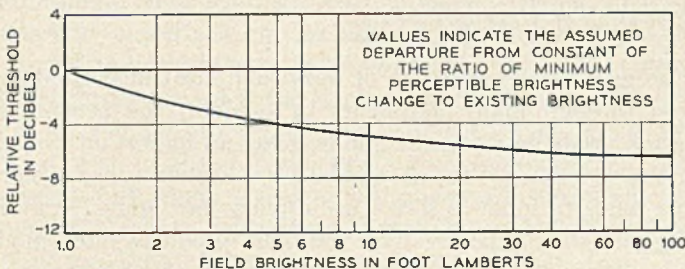

Fig. 12 — Assumed deviation from Weber-Fechner law.



between the two signals, the limitations on achievable maximum transmission levels or magnitudes arise from certain types of second order modulation products rather than from optimizing signal-to-noise performance as in the all-telephone application. One of these types consists of sum products of cross modulation between telephone and television signal components. These form bar patterns and, in so far as signal-to-interference ratio is concerned, are independent of the television signal magnitude. Thus, adjusting such products to equal the appropriate requirement has the effect of setting the maximum permissible magnitude or level of the telephone signal. The second type of limiting product is due to difference frequencies formed by cross modulation among the television signal components. These fall into the telephone channels and, after the telephone level has been set as described above, permit calculation of the maximum permissible television signal magnitude.

With signals set at  $-21$  db level for telephone and  $+6$  dbm unmodulated carrier for television, all of the critical products discussed in section 2.15 above and illustrated on Fig. 8 have adequate margin. The 40 db signal-to-noise objective for 4,000-mile television transmission is met with about 2 db margin and long haul (4,000 mile) message channels meet the  $+29$  dba at the  $-9$  db level objective with about 5 db margin. A margin of about 5 db is also realized with respect to repeater overload performance.

The single frequency pilots are adjusted to have the following values of power at the output of a transmitting amplifier:

7266 kc. ....	$-16$ dbm
8320 kc. ....	$-26$ dbm
All others. ....	$-36$ dbm

With these values, modulation products produced by cross modulation among the pilots and message and television signals all meet the appropriate objectives.

### 2.17 *Frogging of Message Circuits*

When signals, either message or television, are transmitted over long distances through many amplifiers in tandem, the accumulation of modulation products along the line becomes an important system problem for two reasons: (1) the accumulation of certain types of third order products tends to follow a direct or in-phase law and (2) the distribution of modulation products over the band produces more modulation noise in certain parts of the band than in others. Both of these cumulation problems are alleviated if, at intervals along the line, the signals



are shifted with respect to one another in the band, a process known as frogging.

In the L3 system, signal-to-noise performance is substantially improved by frogging the supergroups at intervals of about 800 miles. In the 1,860 channel all-message application, the busy hour signal-to-noise performance of 4,000-mile circuits is alike to within two db with all channels meeting the objective of +29 dba at the -9 db level. In contrast, if frogging were not specified, a substantial number of circuits (10 to 20 per cent would fail to meet the objectives while the performance of other channels would be better than required by six db or more.

When the system is used for combined message-television signals, the message circuits are frogged in supergroup blocks at approximate 800-mile intervals except for supergroups Nos. 113 and 114 which must be frogged at 400-mile intervals. This procedure is necessary to prevent second order sum and difference products of message and television signal components from cumulating excessively, especially those products which involve television signal components close to the television carrier. Frogging these supergroups more frequently than others results in a 3 db improvement in television signal-to-noise performance.

### 2.18 *Special Services Transmission*

During the early design stages, requirements based on the transmission of message and television signals were used to set repeater spacing, to determine the bandwidth and frequency allocations and to fix important design parameters of the amplifiers. Concurrently, the objectives for the transmission of telegraph, program, and telephotograph signals were studied and before the system design crystallized, analyses were made to assure that these special services objectives would be met.

In a few instances it was found that the special services objectives tended to dominate and the system requirements and design were adjusted accordingly. For the most part, however, channels which meet message circuit objectives are satisfactory for special services transmission. In L3, telegraph and telephotograph signals may be transmitted without restriction provided the proportion of these signals does not materially exceed the proportion now installed in the plant. Program signals may be transmitted in the 1,860 all-message arrangement without restriction but when television transmission is provided, program circuits are restricted to supergroups Nos. 113 and 114. This restriction is due to the fact that program circuits are usually more than 4 kc wide; interferences of high magnitude which normally fall between 3,300 and



4,000 cycles or below 300 cycles in message channels of supergroups other than Nos. 113 and 114 would fall close to 4,000 cycles in a program circuit where there is high susceptibility to interference.

### 2.19 *Uncertainties*

In the early stages of system design, firm decisions have to be made on such matters as repeater spacing, bandwidth, and component characteristics. These decisions must be based on a detailed signal-to-noise analysis which in turn involves many judgements of repeater performance parameters, tolerable system requirements and the effects of signal mechanisms on system performance. It would be easy and safe to engineer the system to provide enough signal-to-noise margin to cover the uncertainties in each of these judgements. Conservative engineering of this type could easily have justified a repeater spacing of three miles instead of the four miles actually chosen. Instead, an effort was made to estimate a "mid-range" or most probable value for each performance, requirement or mechanism factor entering into the signal-to-noise design. In addition, a "probable" uncertainty was estimated for each critical parameter. This was usually taken as one third of the maximum foreseeable error in the estimate. Finally, these uncertainties in electron tube modulation, realizable feedback, network impedances, channel requirements, interaction laws between signals and a myriad of other factors were all translated by the signal-to-noise analysis into their effect in db on the television channel signal-to-noise performance. On this basis, the "probable" uncertainties were summed on an rss basis to find the "probable" uncertainty in the overall design. Whereas the direct addition of the probable uncertainties gave a figure of about 20 db uncertainty in the design, the rss addition indicated about six db uncertainty. It was then argued that during the ensuing years of development the probability of finding all the judgements to be wrong in the same sense was extremely small. On the other hand it was deemed reasonable to provide enough margin so that there would be perhaps a 75 per cent chance of not exceeding the margin. Six db of margin was therefore provided, half by clear margin and half by having available economically feasible changes in system design such as a decrease in the telephone channel frogging interval. Any further error in judgement would then have to be taken up by degrading performance below the desired objectives. As the system design proceeded, the early judgements were changed in considerable measure. Likewise, numerous additional system parameters were introduced. However, at no point in the system plan-



ning was the balance of factors such that there was less than three db clear margin.

Margin handled in this way becomes a carefully husbanded asset of the whole system. In designing or analyzing a part of the system a major effort must be made to achieve the performance introduced into the initial determination of repeater spacing and bandwidth. The design of each individual part of the system cannot be allowed a margin which can be used up as the individual designer chooses.

### 2.20 *Equalization Design*

The term "equalization" is used to describe the process of obtaining flat gain and delay characteristics for the system transmission. The system and equipment designs to accomplish this function represent two of the major engineering features of the L3 system. In an overall sense, equalization includes the following: (1) determining deviation objectives for the gain and delay characteristics of the system and its component parts; (2) designing the auxiliary repeater so that the most economical over-all system equalization is obtained; and (3) specifying the location, form and control methods for the mop-up equalizers that are used at intervals along the system. Equalization and its related process, regulation, are the subject of a companion paper;<sup>10</sup> therefore, in this paper only those aspects of equalization will be covered which are necessary for an appreciation of the over-all system design.

### 2.21 *Transmission Objectives*

The requirements on the gain characteristic of a band used for multi-channel telephony depend on two message channel objectives. One of these is that the gain of a message channel must not vary by more than two db over the 4-ke band. To meet this requirement, broad changes in the transmission characteristic of the message band are held to less than 0.5 db for 150-mile links. The second objective stems primarily from the need to transmit telephotograph signals. Since these signals are relatively intolerant of level changes, the transmission characteristics of working lines and protection lines are made alike to within  $\pm 0.25$  db.

The requirements on the gain and delay characteristics of the television band are based on the subjective determination that an echo delayed by about two microseconds or more in a representative picture is considered tolerable by 95 per cent of the viewers when the peak-to-peak voltage of the echo signal is 39 db below the peak-to-peak signal voltage.<sup>11</sup> The translation of this echo objective to allowable variations



in the gain and delay characteristics is straight forward if idealized sinusoidal deviations extending across the whole band are assumed.

In practice, the characteristics of the transmission deviations in a long repeater system are very complex and therefore, the idealized objectives are only a tentative guide in system design. Since we do not have a thoroughly satisfactory method of evaluating complex echo patterns, the exact nature of the final television mop-up arrangements will be determined after subjective tests on the interfering effects of echoes resulting from the complex transmission deviations of representative links of the system.

### 2.22 *The Mop-Up Plan*

The deviations from ideally flat gain and delay transmission characteristics may be classified in three broad categories; (1) fixed deviations; (2) slowly varying deviations; and (3) rapidly varying deviations. The distinction that is made between slow and rapid in the last two categories relates to the frequency of adjustment needed to meet system objectives. Those variations which require adjustment more often than once a week are considered rapid and those requiring adjustment at longer intervals are considered slow.

Corresponding to each of the three classifications of deviations is a set of equalizers, fixed, manually adjustable, or automatic under control of the pilot or a temperature sensitive element. Networks capable of fulfilling the functions of each are distributed along the line according to carefully prepared rules which enable system objectives to be economically met. The locations of these equalizers, their functions and general characteristics are illustrated in Fig. 13.

#### 2.221 *Fixed Equalizers*

To the extent that the auxiliary repeater is designed so that its nominal gain compensates for the loss of four miles of coaxial, it may be considered as the first step of fixed equalization. In addition to the amplifier, the auxiliary repeaters are equipped with artificial lines, which are used to build out the loss of short sections to the equivalent of four miles of cable, and basic equalizers which provide for differences in the loss characteristics of different types of cable.

The second and final step of fixed gain equalization is known as a design deviation equalizer. Its function is to correct accumulated deviations due to the failure of the average auxiliary repeater to exactly



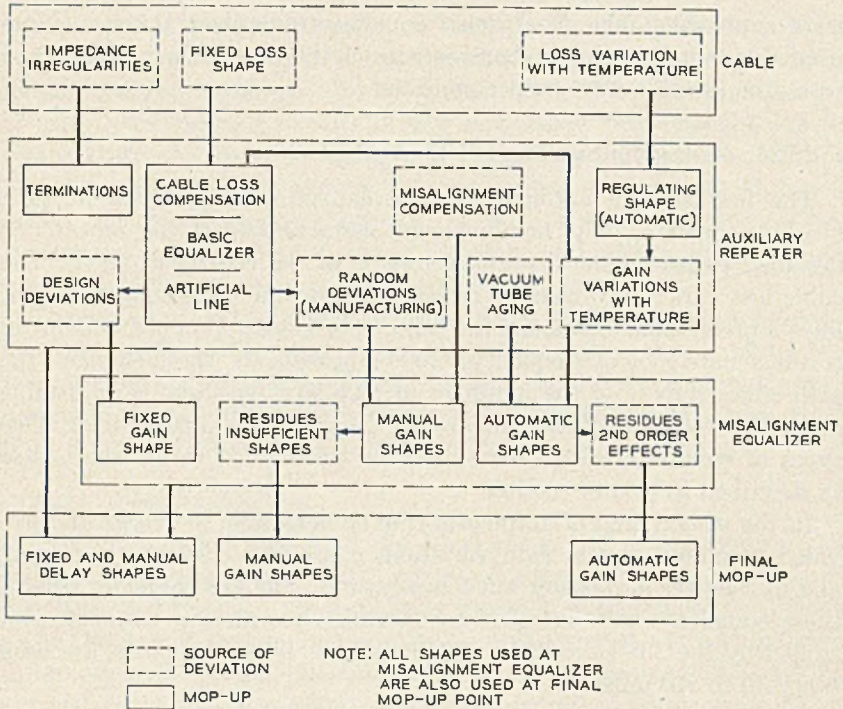

Fig. 13 — L3 coaxial system, equalization plan.

compensate for cable loss. These equalizers will be used at every mop-up point, at 40 to 120-mile intervals.

When television is transmitted, fixed delay equalizers are used at approximately 150-mile intervals. These equalizers compensate for the delay distortion introduced by the cutoffs of the auxiliary repeater sections.

### 2.222 Manually Adjustable Equalizers

The manually adjustable gain equalizers consist of networks whose loss-frequency characteristics are related to one another by a Fourier series type of representation. The number of terms of the series required to meet system objectives varies with different types of mop-up points and depends on the system application being provided for, all-message or combined message-television service. Equalizers of this type are used in mop-up points at 40 to 120-mile intervals along the line.

Manually adjustable delay equalizers are provided at approximately 150-mile intervals when television signals are transmitted. These equal-



izers supplement the fixed delay equalizers described above and are needed to trim the delay characteristic of the line in finer detail than would be possible with fixed equalizers.

### 2.223 *Automatic Equalizers*

The first step of automatic-gain equalization is provided at each auxiliary repeater. The nominal gain characteristic of the repeater is designed to match the loss characteristic of the coaxial at 55° F. The cable loss varies with changes in temperature; the variations, however, have a predictable characteristic, being very closely proportional in db to the square root of frequency. To compensate for these changes, the gain characteristic of the amplifier at auxiliary repeaters is adjustable and follows the loss of the cable under the control of a thermistor. Two types of circuits are used to control the current fed to the thermistor as described in a later section.

In the second step of automatic gain equalization, networks are provided to match system gain variations caused by electron tube aging and by changes in repeater hut temperatures. The loss characteristics of these equalizers are controlled by thermistors which in turn are controlled by the 308-ke and the 2064-ke pilots. These equalizers are used every 40 to 120 miles.

In the final step of automatic gain equalization, networks are provided to compensate for second order effects of the first three rapid variations described above, namely, cable loss variations, and repeater gain variations due to hut temperature changes and electron tube aging. The loss characteristics of these networks are under control of thermistors acted on by the 556-ke, 3096-ke and 8320-ke pilots. These equalizers are located at approximately 150-mile intervals.

The thermistors which control the loss-frequency characteristics of automatic equalizers are driven by regulators through a simple form of analog computer. The design and operation of this circuit is described in a companion paper.<sup>10</sup>

There is no automatic control of the delay characteristic in the system except that provided by the automatic gain equalizers. Every effort is made to have these equalizers match the transmission changes outside the band so that resulting delay changes in the band are minimized.

### 2.23 *Equalization System Considerations*

Whether the system is being equalized for telephone or television it is immediately apparent that the channel requirements described

earlier applied after 4,000 miles of transmission imply that, with no equalization, stability of the transmission characteristics of the individual repeaters would have to be of the order of a few ten thousandths of a db. Obviously, stabilities of this magnitude with changes due to temperature, electron tube aging and manufacturing processes cannot be achieved. Therefore, the equalization system design must be based on an economical balance between the cost of achieving repeater accuracy and stability and the cost of providing and maintaining an elaborate system of fixed, manual, and automatic equalizers.

The equalization problem involves so many variables that no attempt has been made to evolve a unified theoretical basis for evaluating the factors entering into this economic balance. However, in planning and designing the L3 system a number of principles and points of view have been developed which have guided the equalization planning.

### 2.231 *Misalignment*

The transmission objectives described above are determined on the basis of delivering satisfactorily equalized signals at terminals. In addition to this function the equalizers must limit the signal excursions along the line so that excessive noise or modulation is not accumulated in the repeater system. The amount of signal misalignment that can be allowed to accumulate before the first mop-up equalizer depends of course on the signal-to-noise allowance that has been made for this purpose. The amount of signal-to-noise performance allotted to misalignment must represent a balance between the reduced repeater spacing and increased complexity of equalizers that it costs and the increased spacing between mop-up equalizers and increased repeater deviations that it allows.

The engineering method for arriving at this balance represents an interesting example of system design by successive approximations. For example, the total gain area available (over an infinite frequency range) in a coupling network is inversely proportional to the capacity across the network and one of the important design choices is the extent to which one tries to utilize this area in the transmitted frequency band. The degree to which the available gain is concentrated in-band is called the resistance integral efficiency. In the very early stages of the amplifier design it was necessary to choose resistance integral efficiencies and frequency characteristics for the coupling networks. In a definite but complicated way these parameters are related to the sensitivity of the networks to element variations. Efficient networks give improved signal-to-noise performance but also increase the sensitivity to element



changes. By examining deviation curves for a number of specific network designs, tentative choices were made of 50 per cent resistance integral efficiency for the coupling networks and an allocation of about half the cable slope to the pair of coupling networks and the remainder to the feedback network. With an amplifier employing these networks a detailed study was made of the noise and modulation penalties at two frequencies resulting from misalignment in several lengths of line. This study indicated that with certain refinements in the repeater design the misalignment in twenty or more auxiliary repeater sections could be tolerated with a signal-to-noise penalty of about 2 db which was judged to be a reasonable allotment for this purpose. In addition, this study brought out: (1) that randomizing the variations of an element between its normal manufacturing limits resulted in a 4/1 reduction in the required misalignment allowance as compared with accepting large numbers of elements at one extreme of their limit; and (2) a small amount of gain adjustment at each repeater in the vicinity of the high magnitude television carrier would reduce the required misalignment allowance by about 2/1. Refinements on this plan for handling misalignment had to wait until the signal-to-noise and repeater design were crystallized. However, the study referred to above provided a powerful tool for evaluating proposed element deviations during the design period.

When the exact signal levels and the most limiting modulation products became known and when the repeater characteristics and final element deviations were determined it became possible to make a refined study of misalignment in terms of the noise and modulation impairment associated with specific signals and distortion products. At this point performance margins associated with specific interferences could be used to allow more or less misalignment of the particular signal components forming the interference. Likewise, amplifier deviations with specific frequency characteristics could be evaluated exactly in terms of their effect on the number of repeaters between mop-up equalizers. By studies of this type it was determined that the "A" or misalignment equalizers could be spaced at intervals not to exceed thirty-two auxiliary repeater sections.

### 2.232 *Distribution of Element Deviations*

The methods of statistical quality control used to monitor the process of manufacture provided the necessary techniques for obtaining the desired randomization of deviations. A companion paper<sup>12</sup> presents the techniques that were developed to apply the broad field of knowledge

on quality control to the specific needs of the L3 system. The most important point to appreciate in this connection is that the control of the process of manufacture (as well as the end electrical requirements) of individual elements is being used as a basic factor in the design of the system.

### 2.233 *Repeater Accuracy*

In developing the equalization plan it is a logical and straight forward operation to provide shapes and ranges in the equalizers that will compensate for the random variations of known elements. Likewise, real but indeterminate parasitic elements can be taken into account by specifying the final characteristics of the line amplifier feedback network and the equalizer fixed shapes (design deviation equalizers) on the basis of measurements on a rigidly controlled group of amplifiers that are deemed to be representative of the final product. However, having once specified the equalization on this basis the design elements and indeterminate parasitic elements must be held to the values and ranges upon which equalizer location, shapes and ranges are specified. This point of view has led to rigid mechanical control and the omission of component adjustments in the line amplifier which represent a departure from other transmission systems. These features are discussed in detail in the companion amplifier paper.<sup>8</sup>

## 2.3 NEW YORK-PHILADELPHIA TRIAL

The first installation of L3 has been made between New York and Philadelphia. Since the middle of 1952, this installation has been used to test components, to verify values of important system parameters used in system analyses, and to gather data for the further design and development of equalizers.

Random noise measurements have confirmed theoretical values (Fig. 5) to an accuracy of better than 2 db. In general, the measurements have indicated that the theoretical values have been conservative.

Measurements of system modulation performance, made with single frequency tones, also confirm the theoretical values used in analyses. Third order modulation measurements are in almost complete agreement with theory while second order measurements have been generally two to three db more favorable than the analytic values used.

Transmission measurements have confirmed that equalizer networks designed so far are satisfactory for systems to be installed in the near future. Further measurements are required to determine automatic



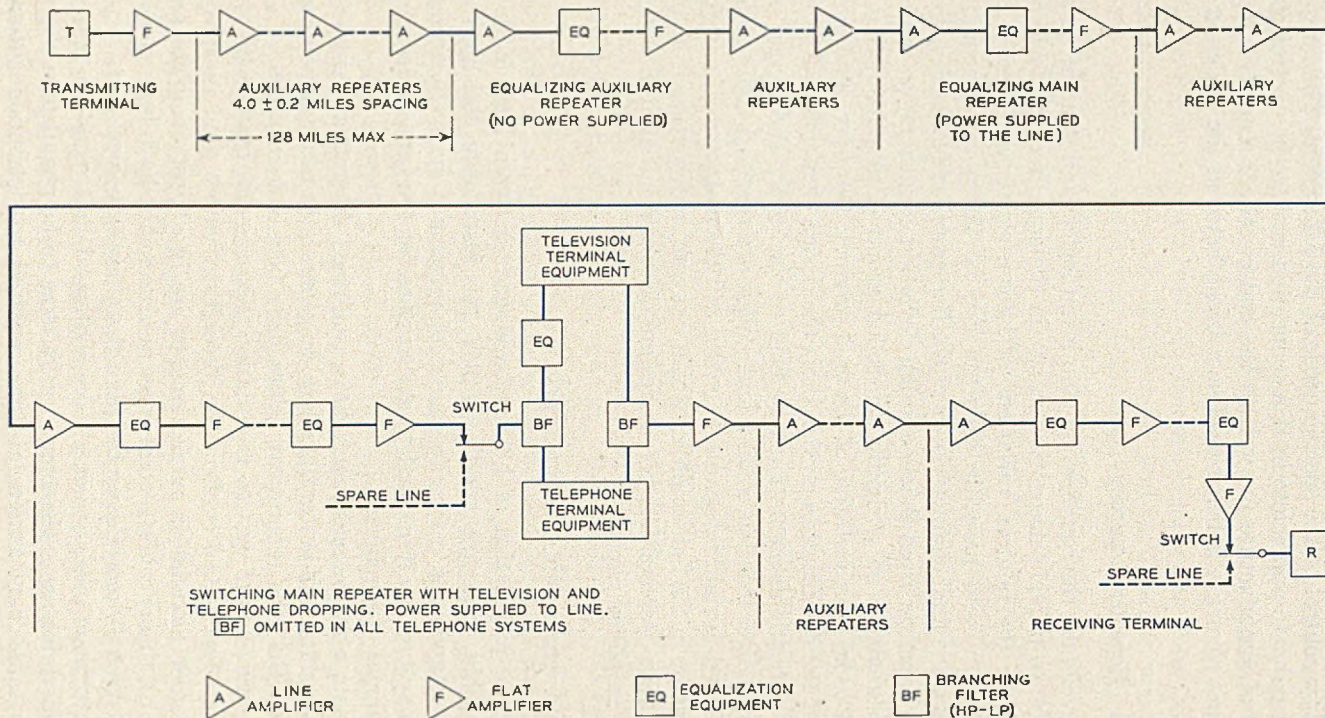

Fig. 14 — General layout of L3 repeaters.



equalizer shapes to correct for the second order effects of temperature changes and electron tube aging. Also under active study are the problems associated with final mop-up for long television systems.

### 3.0 SYSTEM DESCRIPTION

#### 3.1 GENERAL

In the preceding sections on system design the functions of the auxiliary repeaters and the need for additional repeaters with varying amounts of equalization have been brought out. Fig. 14 shows the transmission layout of a typical L3 system. The auxiliary repeaters contain amplifiers and regulating equipment to compensate for the basic cable loss and its variation with temperature. Since such repeaters are dependent on the cable for their primary source of power they are called auxiliary repeaters.

At points in the system where additional first order equalization is required to reduce misalignment the complexity of the repeater equipment increases and such repeaters receiving power over the cable are called equalizing auxiliary repeaters.

The distance which power may be transmitted over the cable to the auxiliary repeaters is limited; therefore, repeaters at specified intervals must be capable of supplying power to the cable. These are called main repeaters. They may be equalizing main repeaters where only first-order equalization is required or switching main repeaters where lines are switched or circuits dropped.

#### 3.2 AUXILIARY REPEATER

##### 3.21 *Transmission Circuit*

The auxiliary repeater is the basic unit of the system and its design determines to a great extent the performance and economics of the system. A block diagram of such a repeater for transmission in two directions on two coaxials is shown in Fig. 15. The power separation filter (PSF) is a six terminal high pass-low pass filter designed to separate the high frequency transmission signals on the coaxial from the low frequency current transmitted on the center conductor to furnish primary power to the repeater power equipment. At the input to the repeater the low-frequency current is diverted to a power supply while the high-frequency current follows a path through passive networks to the input of the amplifier. At the output, the signal from the amplifier and the low-frequency current from the power supply are recombined in the power separation filter for transmission to the next repeater.



The power separation filters are basically simple designs, but the realization of the theoretical design was complicated by the following: (1) the components in the low frequency section must pass currents of about 1.5 amperes without change in characteristics, and must withstand potentials as high as 2,000 volts rms without generating corona noise; and (2) the components in the high frequency section must be such that the loss over the transmission band (300–8,350 kc) is small and stable and of such a shape that it is easily equalized. To meet these requirements stable inductors and capacitors with a minimum of parasitic resonances in the band were designed.

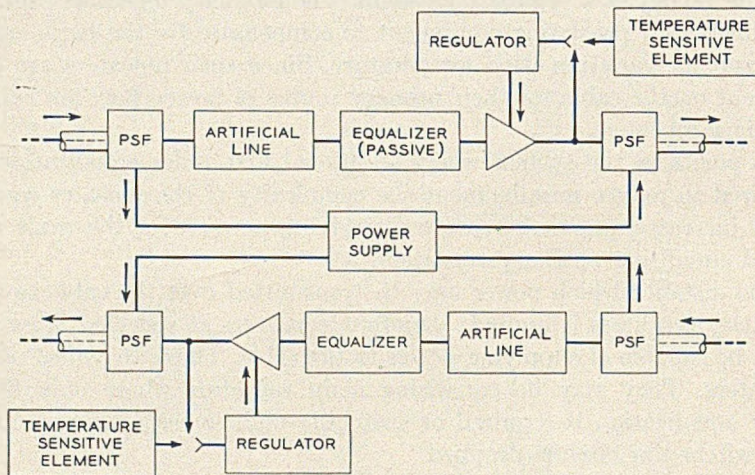

Fig. 15 — Auxiliary repeater.

The artificial line shown preceding the input to the amplifier is a passive network to build out the loss-frequency characteristic of a short cable section to be equivalent to the loss-frequency characteristic of  $4.0 \pm 0.2$  miles of 0.375" cable or  $2.87 \pm 0.15$  miles of 0.27" cable. These lines are provided in several different sizes, so that, where it is impossible physically to locate the repeater within the specified accuracy of 0.4 mile this accuracy can be obtained electrically. The design of the network is such that an accurate and stable characteristic is obtained with a minimum number of components.

The equalizer is a means for compensating for small variations in the transmission characteristics of coaxial cables due to variations in the physical construction of the cable. In the case of the most generally used cable, this equalizer inserts only a small flat loss.

The amplifier is of the feedback type whose gain frequency char-



acteristic is closely equivalent to 4.0 miles of 0.375" coaxial cable plus the loss of the other passive elements in the repeater. This unit is demountable without tools for maintenance and is sealed in a die cast housing as protection against moisture and dust. The detailed electrical and mechanical design are covered in a companion paper.<sup>8</sup>

The *regulator* may be one of two types. The first, called the auxiliary regulator, adjusts the gain-frequency shape of the amplifier in accordance with the magnitude of the 7,266-ke pilot transmitted along the line. The second type, the thermometer regulator, adjusts the gain-frequency shape of the amplifier under control of an element representing an average value of cable temperature. This element is a thermistor buried in the ground near the cable. Such a control is, obviously, not as accurate as pilot controlled regulation, but it is adequate for use at one-half of the auxiliary repeaters and its simplicity results in considerable saving in first cost and power requirements. The regulators are demountable units similar to the amplifiers. Their detailed electrical and mechanical design are covered in a companion paper.<sup>10</sup>

The pilot alarm unit is provided with auxiliary regulators to indicate pilot deviations beyond a predetermined limit. Its operation will be described a little later in connection with the discussion of alarm and control arrangements for the entire system.

### 3.22 Power Supply

Primary ac power for the auxiliary repeater is supplied on a constant current basis from the main repeater over the center conductors of the two associated coaxials. Power generating and control equipment used at the main repeater will be discussed in Section 3.6. At the auxiliary repeater, power supply equipment is required to convert the primary power to suitable voltages for heater, plate and bias use as shown on Fig. 16. Half of the input to the power supply is taken from each center conductor and the output of the power supply is used to power the entire two-way repeater.

The heater voltages are obtained by simple transformation which is complicated only by the fact that accurate and low loss transformers are required and the primaries of these transformers must withstand high ac potentials without generating corona noise which might be transmitted through the power separation filter to the input of the amplifier. Two separate transformers are used to split the load between the two center conductors even though the secondaries are connected together to feed the repeater. This arrangement eliminates one crosstalk path



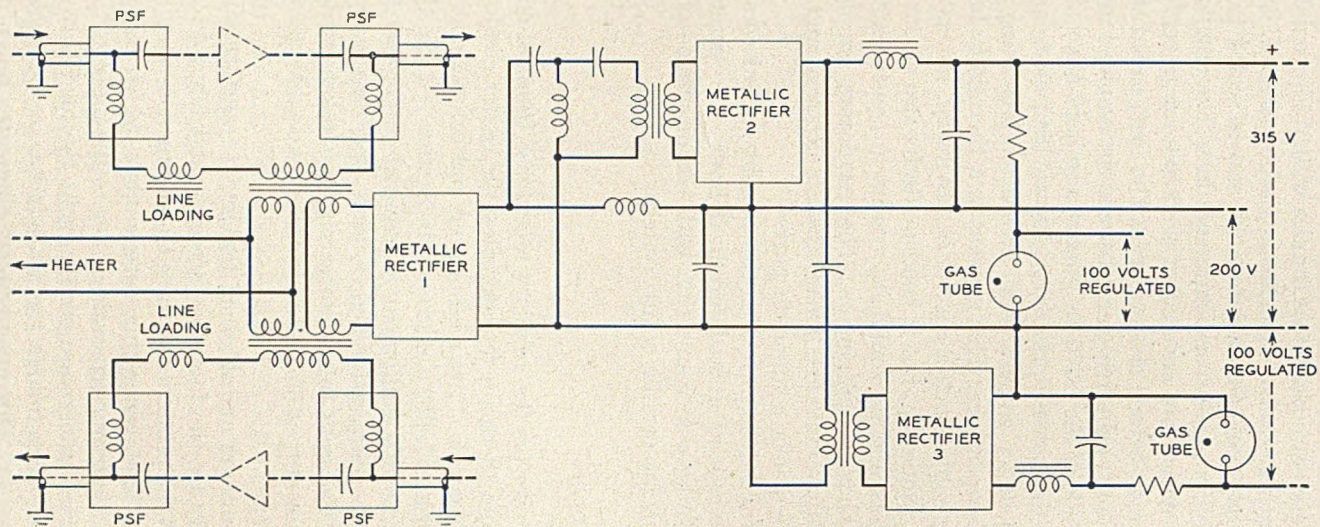

Fig. 16 — Auxiliary repeater power supply.



at low frequencies where it is difficult and expensive to design power separation filters to meet the system requirements.

The dc plate and bias supply voltages for amplifiers and regulators could be obtained by conventional rectifier circuits except for one complication which such arrangements introduce. This complication is the fact that a rectifier terminated in a low-pass filter (conventional ripple filter) reflects a highly distorted current wave into the primary circuit. If the primary current is so distorted the various power supplies in the series circuit will be fed with other than a sine wave of current and will supply different voltages depending on the wave form. Since the heater power depends on the rms value of current while the dc output depends on the peak value of voltage, it is easily seen that the relationship between these two will change with the wave form of the applied current. Furthermore, the line loading to be discussed later must be calculated on the basis of a pure sine wave; appreciable harmonics in the line current tend to make it impossible to predetermine the loading to any reasonable degree of accuracy.

It was found that these problems could be avoided and the power factor of the power supply made very nearly unity if the rectifier (RECT 1) was terminated in a constant resistance load rather than a low-pass filter. This was provided by paralleling the conventional low-pass filter with a high-pass section terminated in the proper resistance load. To avoid wasting the power in this load a second rectifier was added (RECT 2). The dc output of this circuit is used in series with the main dc supply to provide the higher voltage required for the output stage of the amplifier. This rectifier must also be terminated resistively although its effect on the main current wave is less than that of the first rectifier, and the power dissipated is smaller. Since there was a further use for a small amount of power for bias in the regulators, RECT 3 was added to produce a regulated voltage in conjunction with a conventional gas tube circuit. This rectifier and its load provide the termination for the high pass section of the filter circuit for RECT 2. A second gas tube circuit is used to obtain a regulated bias supply for amplifiers and regulators from the 315-volt source. The loads on both gas tube circuits are fixed so regulation for variation in input voltage only is required. For this reason a low current, highly stable gas tube could be used.

### 3.23 *Power Loading*

The power transmission circuit of a power loop is essentially a resistance-capacity network at the power frequency. The line and the



power supply resistance are the resistance component and the line and power separation filter capacity to ground make up the shunt capacity. If the circuit were used in this form the primary current at each repeater would be different since it would be the vector sum of the current in the succeeding section and the current in the shunt capacitance. This is undesirable as the objective is to make all power supplies alike. A familiar solution is applied to this problem by inserting an inductive reactance in series with the line. A value of this reactance is chosen for each repeater to compensate for the current through the effective shunt capacitance and thus make the currents through each of the power supplies as nearly alike as possible.

To simplify the loading adjustment in the L3 system a continuously variable loading inductor was developed. This arrangement allows more accurate adjustment of loading without the complications of changing wiring taps in a high voltage circuit. The design of such an inductor presented formidable obstacles as a large range of variation was desired (20–120 mh), and relatively high currents and voltages were involved. The device used consists of the two inductors which may be rotated with respect to each other, so that the coupling between their magnetic circuits varies ideally between zero and 100 per cent. One inductor is inserted in each side of the power circuit and a net result is obtained which is equivalent to varying each inductor.

### 3.24 *Physical Description*

The type of auxiliary repeater generally used is shown in Fig. 17. It consists of a 6-foot cable duct framework upon which the component panels are mounted. It is completely wired in the factory. The lower third of the bay contains the power supply equipment while the upper part contains two transmission panels. One panel is provided for each direction of transmission and all of the transmission components of the circuit are found on these panels. The demountable units, amplifier, regulator, and pilot alarm unit are interconnected with plugs and jacks, so that they may be removed for maintenance. The other units are interconnected by screw-type terminals and cable as it is expected that they seldom will require maintenance.

Other types of repeaters will be available to meet special conditions such as manholes where sealed apparatus cases will be required to prevent damage due to water submersion, or telephone offices where standard 11'-6" frameworks are usually desired.



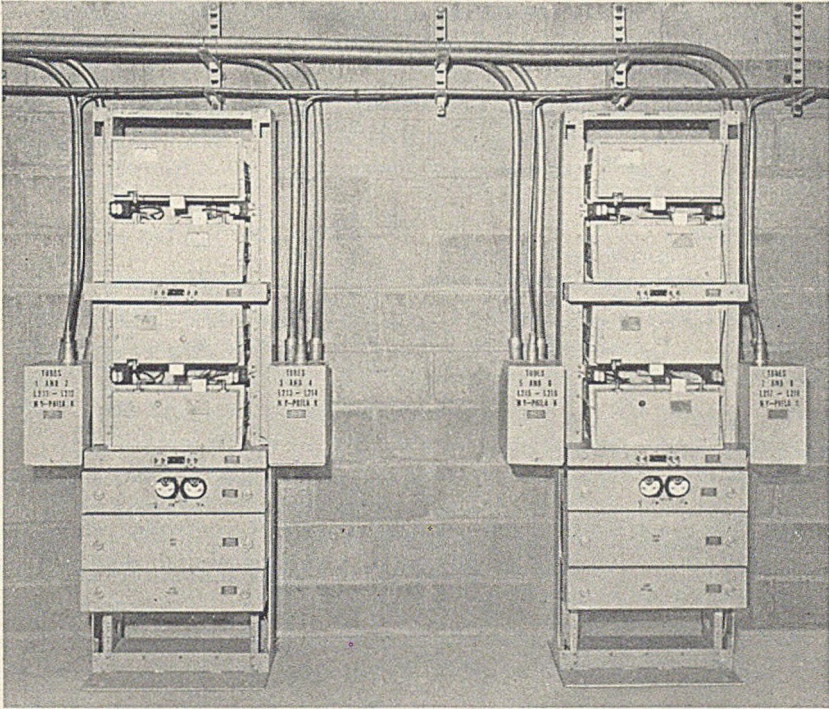

Fig. 17 — Typical auxiliary repeater in concrete block wall.

### 3.3 EQUALIZING AND SWITCHING REPEATERS

#### 3.31 *Components*

The equalizing auxiliary and main repeaters use the same general types of transmission equipment as the auxiliary repeater except for the equalizers. They differ principally in the quantity of equalization equipment provided and the bay arrangements. Table IV lists a summary of the basic transmission units in each repeater.

At these repeaters a line amplifier is used as a receiving amplifier to compensate for the previous section of cable. Flat amplifiers are used as transmitting amplifiers and to compensate for the loss introduced by the equalizers. They have a flat gain-frequency characteristic and no provision for pilot control of their gain. Their design is very similar to that of the line amplifier and is covered in the companion amplifier paper.<sup>8</sup>



TABLE IV—SUMMARY OF HIGH-FREQUENCY LINE EQUIPMENT  
AT REPEATER STATIONS

	Auxiliary	Equal- izing Aux.	Auxil- iary Main	Switching Main (Tele- phone only)	Switching Main (Tele- phone — TV)
Line amplifier.....	1	1	1	1	1
Flat amplifier.....	0	2	2	5	5
Auxiliary or thermometer regulator.....	1				
Manual equalization (Number of terms).....		10	10	15	25
Automatic equalizers.....	1	3	3	6	6
Regulators for equalization (kc).....		7266	7266	7266	7266
		308	308	308	308
		2064	2064	2064	2064
				3096	3096
				556	556
				8320	8320
Design deviation equalizer.....		1	1	1	1

The functions of the fixed, manual and pilot controlled equalizers are noted in Section 2.22 of this paper and discussed in detail in the companion equalization paper.<sup>10</sup>

### 3.32 Equalizing Auxiliary Repeaters

This type of repeater will be found after a maximum of thirty-two auxiliary repeaters provided power feed to the cable, dropping, or switching is not required (Refer to Fig. 14). The major components provided are covered in Table IV. In addition to these items, power separation filters, basic equalizers and artificial lines identical with those in auxiliary repeaters are used. A pilot alarm unit is also included to monitor each of the three regulators and transmit an alarm when any one of the controlling pilots has deviated beyond a given limit.

Power for these repeaters is obtained from the cable just as in the case of the auxiliary repeater and much of the same type of equipment is used. However, due to the larger amount of power required and the layout of the repeater the auxiliary repeater power units have been re-packaged to provide the optimum arrangements for leads carrying high current or critical bias supply circuits.

The design of panels used in this repeater was dictated by the general scheme conceived for the switching main repeater where the maximum amount of equipment is required. This arrangement involves the use of both sides of a duct-type frame. A single panel (again called the transmission panel) is used, but an amplifier is mounted on one side and a



regulator is mounted on the other. This requires access to both sides of the bay, but results in an overall saving in the number of bays and overall floor space.

All of the transmission components and a heater and bias supply unit are mounted in one 7' bay for each coaxial. The plate and primary ac power for two of these bays is mounted in another 7' bay.

### 3.33 *Equalizing Main Repeater*

This repeater contains exactly the same transmission equipment as the equalizing auxiliary repeater (see Table IV). It differs in the function noted before, that is, it is equipped to feed power to the cable. The equipment to perform this function will be described later in the paper. Since the repeater can feed power to the cable it can also supply the power for its own operation. This power is derived from the primary ac supply used for the line by means of conventional metallic rectifiers for dc circuits and transformers for the ac heater supplies. These power supplies are not a part of the power loop containing auxiliary repeaters, so no special arrangements are required to obtain good waveform or high power factor.

The equipment arrangement uses the same units as the equalizing auxiliary repeater, but here conventional 11'-6" frames are used.

### 3.34 *Switching Main Repeater*

Usually, this type of repeater is supplied at the point where circuits are dropped or terminated. In order to permit switching from a working line to a spare line in case of trouble, see Section 3.4, more complex equalization is required so that the lines will be as nearly alike as possible when the switch takes place. Furthermore, the signal delivered to the terminal must meet equalization limits that will result in a satisfactory grade of service.

Where the repeater is part of a system required to transmit only message circuits the basic equipment shown in Table IV (telephone only case) is required. In addition to these units facilities are provided which indicate and alarm pilot levels and provide for patching and other maintenance arrangements. Since this repeater always feeds power to the cable it uses the same power arrangements as the equalizing main repeater.

When the system is being used for the combined telephone and television signal this repeater is the same as the "all telephone system" repeater except that it has additional equalization equipment to adjust



the system for the more stringent television requirements. Furthermore, line connecting equipment consisting of branching filters and additional equalization is required. Branching filters are used to separate the telephone and television bands so that they can be transmitted to their respective terminal equipment. These are combined high-pass low-pass structures complicated by strict requirements on stability of the gain-frequency and delay-frequency characteristics. Delay equalization for the line sections must also be provided in the television branch and a large part of this is combined with the branching filters. Other components required for long television systems are adjustable gain and delay equalizers and associated amplification.

The same type of equipment is used as that described for the other repeaters except that a number of additional transmission panels are required to mount the additional amplifiers and regulators associated with the equalizers. Two 11'-6" bays are used to contain the equipment for one through coaxial. One bay contains the receiving equipment which precedes the line switch. The other bay contains the transmitting equipment (transmitting amplifier and hybrid) and any line connecting equipment for combined systems. Fig. 18 shows a typical main repeater installation.

### 3.4 AUTOMATIC SWITCHING\*

In order to preserve transmission in the event of the failure of a component of the system and for transmission maintenance purposes, one coaxial in each direction is operated as a standby. An automatic switching system is provided to permit substitution of the standby line for any of the working lines. The lines are switched at the input to the transmitting amplifier and at the output of the receiving amplifiers and equalizers. (See Fig. 14).

At the receiving end of a switching section, equipment is provided whose function is to recognize failure of a working line and initiate the switching circuits. Information as to the transmission conditions of the system exists in the pilot regulators, the output of which controls a sensitive relay with high and low limit contacts. The operation of one of these relays provides the switching system with the information that transmission has failed or been seriously impaired. It is necessary to make a switch as rapidly as possible in the case of a total failure in order to reduce the effect upon the transmission circuits. As the relays take appreciable time to operate, the receiving switch equipment is designed

\* Material written by P. T. Sproul.



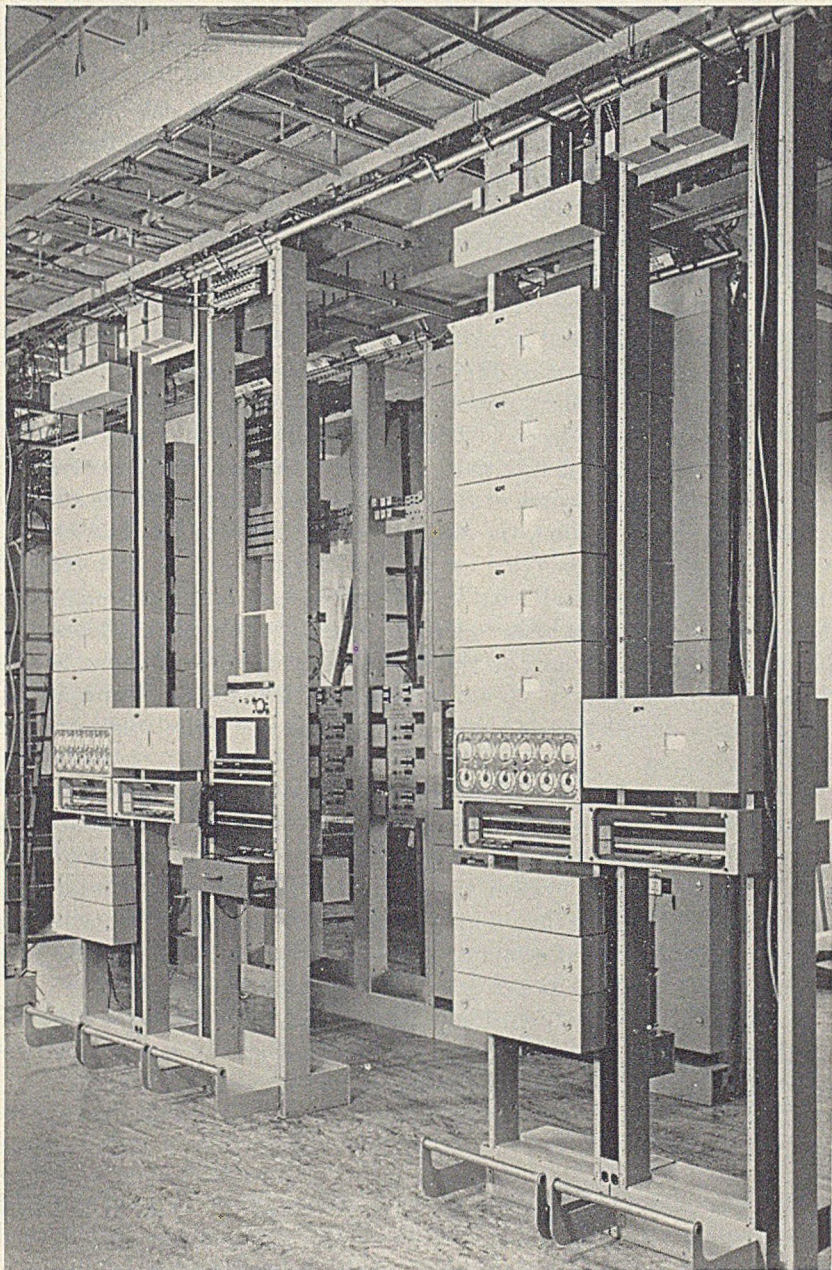

Fig. 18 — Typical main repeater installation.



to operate directly from the dc output of the regulator associated with the 7,266-kc line pilot. This permits complete switch operation in about 15 milliseconds.

Upon receipt of information from the regulators that one or more of the pilots have gone out of limits, the switch initiator signals the transmitting switch control equipment at the transmitting end of the switching section as to which line has failed. Signalling is accomplished by the use of tones in the 280 to 296-kc range which are transmitted over all coaxials in parallel in the reverse direction. Use of the coaxials for transmission of these signals obtains maximum speed of operation of the switch. All paths are used in parallel to preclude failure of the switch if one channel in the opposite direction would be inoperative.

The transmitting switch control equipment causes the transmitting end of the standby line to be switched in parallel with the line in trouble and then signals the switch initiator that this has been done. This verifier tone actuates the line switch at the receiving end to complete the switch.

When the trouble clears, the switch is released as the initiator checks every minute to see if service on the working line can be restored. In the event of a prolonged trouble, the switch can be locked manually and the initiator will no longer attempt to restore to normal. Release of the switch is accomplished by the transmission of a release tone to the transmitting end while a checking tone returned by the transmitting end indicates completion of release and readies the switch initiator for further switching.

For maintenance purposes, manual operation of the switching equipment is provided. In effect, manual switches are made by simulating a failure. Alarm features are provided to indicate to the operating personnel failure of the coaxial system or failure of the switching equipment. Care has been taken in the design to insure that failure of the switching equipment in no way affects transmission except by removing the protection afforded by the presence of the switching facility.

One 11'-6" bay is required for the switch control equipment for each direction of an 8-coaxial system. The line switches are mounted in the miscellaneous bay of the main repeater lineup.

### 3.5 TERMINALS\*

Television terminal equipment, which is required to modulate the video frequency signals to and from the high-frequency line, is described in a companion paper<sup>9</sup> and therefore, will not be discussed here.

\* Material written by C. G. Arnold.



The telephone terminals consist of modulators (and related transmission equipment) and carrier and pilot generating equipment. The transmission components of a terminal for an all message system are shown on Fig. 19. The channel, group and supergroup equipment are designs previously used in the L1 system. The designs of the submastergroup and mastergroup units employ circuit arrangements similar to those used in the supergroup equipment. The greater bandwidths, higher frequencies and more severe stability requirements required new components and improved circuit and layout techniques.

Fig. 20 shows the modulation steps and location in the frequency spectrum of the supergroups, submastergroups and mastergroups when the L3 system is used for telephone and television or all telephone. Mastergroup one comprises the first ten sixty-channel supergroups. This mastergroup is placed directly on the line in the 564 to 3,084-kc frequency band for both the telephone-television and all-telephone cases. When the system is used entirely for telephone, two additional mastergroups are formed by modulating mastergroup one up into the desired frequency bands.

Mastergroup No. 1 is subdivided into two submastergroups. The lower six supergroups, comprising submastergroup one are modulated directly up from the basic supergroup located in the 312 to 552-kc band. The modulation and carrier supply equipment for these supergroups are the same units that are employed in the L1 system. The upper four supergroups comprising submastergroup two are obtained by modulating four supergroups located in the same frequency range as the top four supergroups in submastergroup one into the top part of mastergroup one.

The supergroup numbering system used for L3 has been adopted for easy identification of supergroups in their high-frequency positions. Each supergroup is given a three digit number. The first digit identifies the mastergroup, the second digit identifies the submastergroup, and the third digit identifies the L1 supergroup from which it was originally derived.

In the 1860 channel all-telephone allocation, supergroup No. 112, which corresponds to the basic L1 supergroup No. 2, may be used for high quality, long haul message circuits. When the system is used for telephone and television, supergroup No. 112 is restricted to circuits under 200 miles in length because of intolerable second order cross modulation between these signals and the television signal.

With these groupings of channels new modulating and carrier supply equipment is required for submastergroup No. 2 and mastergroups Nos.



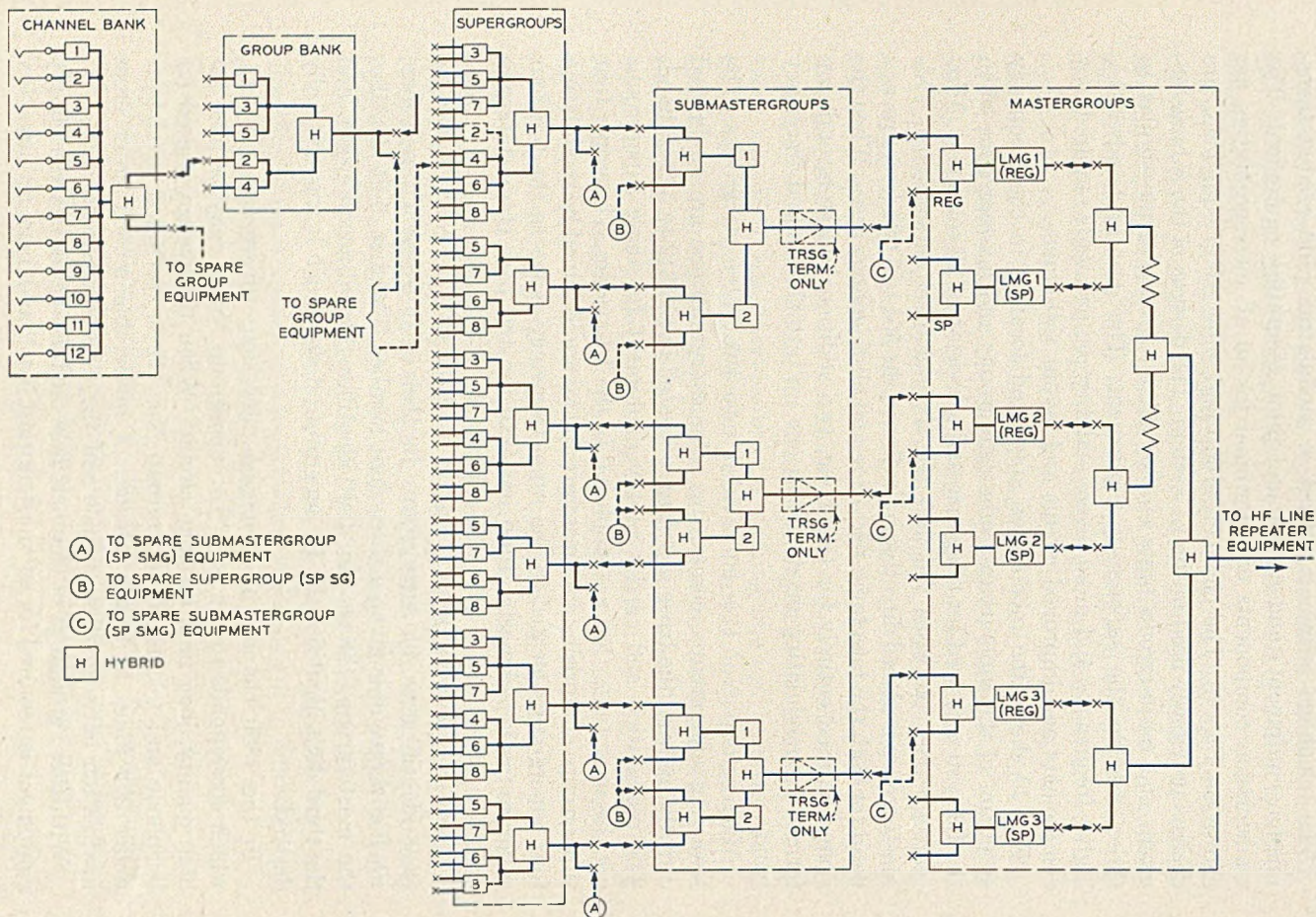

Fig. 19 — Terminal transmission equipment for an all-message system.







2 and 3. The frequency allocation and modulation steps shown on Fig. 20 were chosen so that good performance could be obtained with relatively inexpensive filters used for suppressing unwanted sidebands and to develop lower sideband signals appearing right side up for transmission over the high-frequency line. The carrier frequencies used in the modulation steps were chosen so that some of the same filters could be used in the submastergroup two and mastergroup two and three modulators. The clear bands between the submastergroups and the mastergroups were chosen to permit the use of economical blocking filters at repeaters where circuits are to be dropped from the high-frequency line and to provide frequency space for the line pilots.

It will be noticed in Fig. 19 that facilities are provided for patching spare equipment into service for maintenance reasons or in the event of a failure in working units. Alarm features are incorporated in the submaster group and mastergroup units to indicate trouble conditions and initiate maintenance procedures.

The carriers required for the channel, group and supergroup units are supplied by equipment developed for the L1 system. The arrangements for supplying the new carrier and pilot frequencies are shown in Fig. 21.

A problem of primary importance in carrier supply design is the accuracy of the frequencies. There is both an absolute accuracy and a relative accuracy requirement. For transmission of some types of signals there is a requirement that the difference in frequency between a carrier at two terminals be less than 2 cycles per second. This extreme accuracy is achieved by using the oscillator at one terminal to control the frequency of oscillators at other points. A line pilot generated at the terminal in which the master oscillator is located is used as a reference frequency at points along the line where other terminals are located and by this means carriers are held to a relative accuracy of  $\pm 1$  part per 30 million.

In order that requirements for high quality television transmission may be realized on a 4,000-mile circuit, the output of the pilot supply must be extremely constant with both time and temperature changes. Deviations in the magnitudes of line pilots are maintained to less than 0.05 db.

Since a failure in the L3 carrier and pilot supply could cause interruption to service on an extremely large number of circuits, many precautions have been taken to make the equipment reliable. In addition, standby units, which are automatically switched in place of the regular units in the event of failure, are provided to improve the over-all reliability of the system.



The terminal equipment is normally mounted on standard 11' 6" duct-type bays. The submastergroup and mastergroup equipment required to handle 1,860 channels occupies two complete bays and portions of two others. One carrier and pilot supply is mounted in three bays.

### 3.6 POWER GENERATION AND TRANSMISSION

Power is transmitted to the auxiliary repeater over the inner conductors of each pair of coaxials as noted earlier. A maximum of twenty-one auxiliary repeaters can be fed from a main repeater. This limit is determined by the maximum potential the cable can safely withstand. Shorter spacings are dictated by geographical and plant layout considerations.

The power supplied to the coaxials at the main stations is generated by a motor-alternator set which consists of the alternator, an induction motor, a dc motor and its exciter, all coupled together on the same shaft. Normally, commercial power is used to drive the induction motor. When this source fails or the voltage goes out of prescribed limits the drive is transferred to the dc motor which operates from a 130-volt battery. If the commercial power is unusable for more than  $2\frac{1}{2}$  minutes an emergency engine alternator is started and after a five minute warm-up period it replaces commercial power in driving the regular induction motor.

The constant current to the coaxials is supplied through a power control circuit which accurately regulates it to within  $\pm 1$  per cent of the desired value. A simplified schematic of the power control unit is shown on Fig. 22. The unit consists of two motor driven continuously variable transformers which supply power to the line transformer. The course control variable transformer is relay controlled and maintains the line current within  $\pm 3$  per cent of the prescribed value. The range of this transformer is sufficient to permit reducing the voltage to zero in order to turn down power on the system for maintenance purposes. The fine control variable transformer is regulated by an electronic regulator to maintain the line current within  $\pm 1$  per cent of the desired value.

The change in the line current in response to commercial power transients and transients introduced by changes in the motors driving the alternator requires careful consideration. By increasing the inertia of the motor alternator set with a fly wheel and carefully designing the frequency response of the above described power control regulator a satisfactory transient response has been obtained.

For the maximum length power section the potential applied to



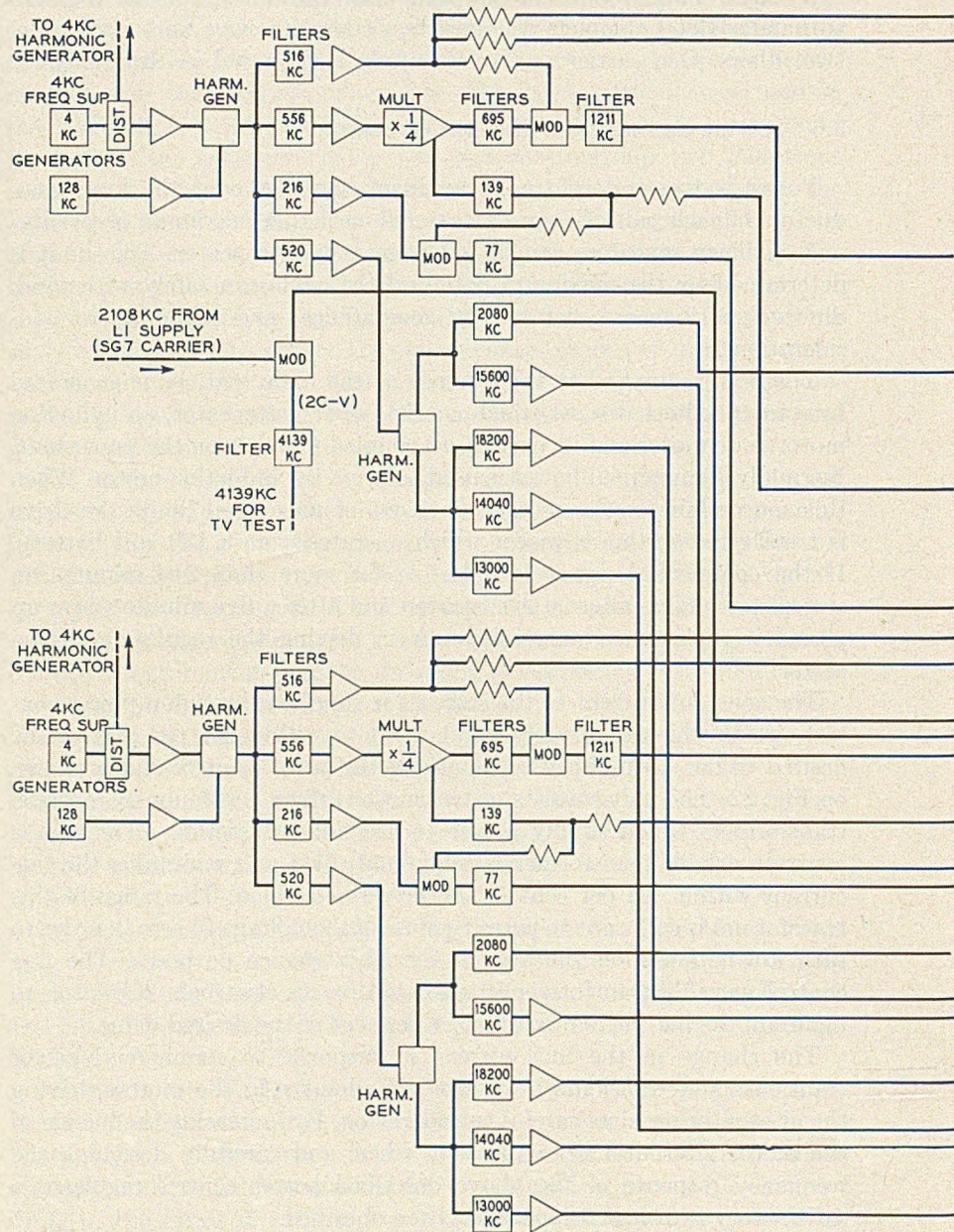
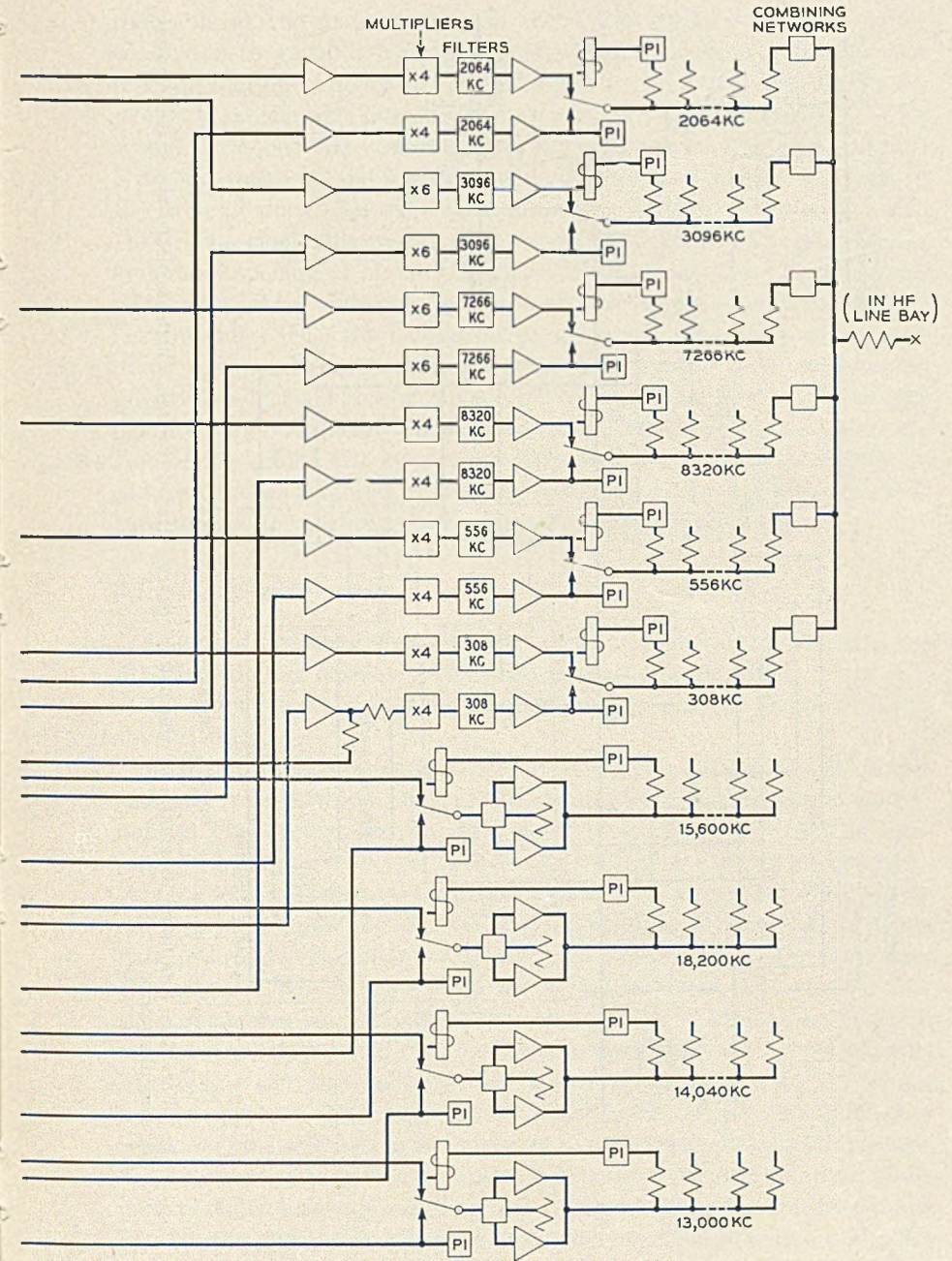

Fig. 21 — Arrangements for supplying



the carrier and pilot frequencies.



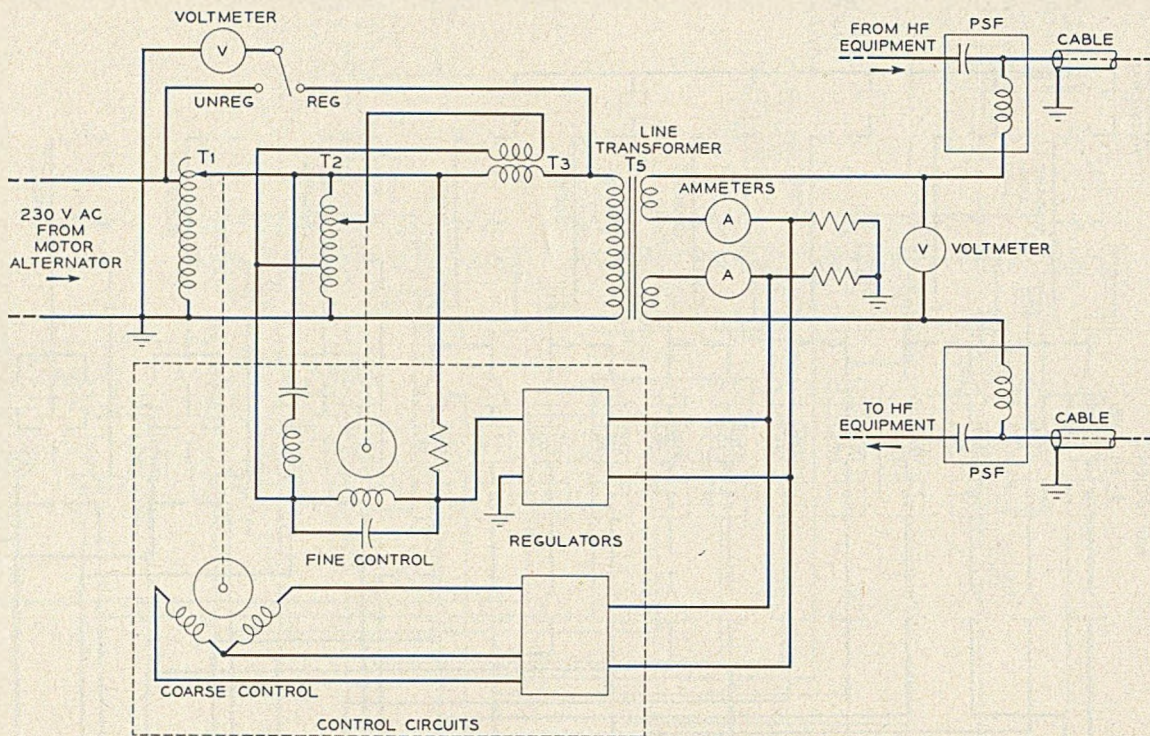

Fig. 22 — Simplified schematic of the power control circuit through which regulated power is fed to the coaxial circuits.



the cable at the main stations is about 2,000 volts rms from center conductor to ground. This potential diminishes about 100 volts per repeater section in going out from the power feed point or as the power section is shortened. (The maximum potential applied to the cable in L1 systems is about 800 volts rms between center conductor and ground). Extensive tests on the installed cable showed that corona develops in the cable at potentials varying in a random fashion between 1,200 and 1,600 volts rms. This would allow power feed points to be placed at a maximum spacing of about 100 miles. By replacing the nitrogen, with which the cables are normally filled, with a large molecule gas, sulfur-hexafluoride ( $\text{SF}_6$ ), the corona potential of the cable is increased well above the maximum operating potential. Only the cable sections exposed to potentials greater than 1,200 volts will be filled with the new gas. Elaborate and thorough tests have demonstrated that no deterioration of the cables will result from the use of this gas. Some additional precautions are required in entering manholes and using high temperature torches for soldering when the  $\text{SF}_6$  gas might be present.

### 3.7 ALARM EQUIPMENT

Since the auxiliary repeaters and certain of the main repeaters are unattended it is necessary that arrangements be provided to indicate at the attended stations when some piece of equipment fails to perform satisfactorily.

Auxiliary repeaters using pilot regulators are equipped with microammeter relays which monitor the operation of the regulator continuously. These relays provide an indication of the operation of the regulator and the power of the 7,266-ke pilot at the output of the repeater. When conditions change from the nominal by a specified amount the relay contacts close and are locked magnetically. This bridges an alarm pair in the cable and operates an alarm at the nearest attended repeater. By means of Wheatstone bridge measurements from this repeater over the same alarm pair, the repeater in trouble can be located and a maintenance crew dispatched to make the necessary equipment replacements. The relays can also be reset over the same alarm pair to aid in the location process or to clear alarms which were initiated at unaffected repeaters by deviations in the pilot due to troubles at preceding repeaters.

At main repeaters, microammeter relays are provided on all six pilots used to control the equalization of the system. Deviations in these pilots operate the automatic switching equipment and initiate the usual office alarms. Alarms are also provided to indicate fuse operation, transfers



from regular to standby equipment, and the condition of electron tubes in the terminal equipment amplifiers.

Provisions for connection to special alarm systems are made at main repeaters which are not fully attended. These systems extend the alarms to the nearest attended repeater and enable the attendant to determine in considerable detail the condition at the remote repeater. The attendant may also perform certain operations such as switching a working line to a spare line at the remote repeater.

### 3.8 MAINTENANCE

Maintenance of the L3 system requires equipment and methods for routine checking of the system and trouble location. Normally the auxiliary repeaters will be visited at intervals of about three months, when checks will be made of the power voltages and currents, the electron tube bias and change in bias with a fixed change in heater voltage (activity), and the pilot magnitudes. At these times amplifiers and regulators which fail to meet prescribed limits will be replaced, the 7,266-ke pilot will be brought to its normal value by adjusting the regulator gain, and the amplifier gain control in the output beta circuit will be adjusted by observing the 3,096-ke pilot.

For these routine tests and adjustments two portable test sets are provided. The power test set plugs into the repeater, amplifier, or regulator and provides for measuring power supply voltage and currents and electron tube cathode-grid voltages to an accuracy of  $\pm 1$  per cent. The pilot indicator makes it possible to measure the 7,266 and 3,096-ke pilots to an accuracy of  $\pm 0.1$  db.

For trouble locations at auxiliary repeaters a portable transmission measuring set has been designed. It is capable of measuring the power in a 500-cycle band at any place in the frequency spectrum from 50 to 11,000 ke to an accuracy of  $\pm 0.5$  to  $\pm 0.02$  db depending on its specific use and the care used in calibration.

At main repeaters, line sections will be checked for noise and modulation performance and equalizers will be adjusted at intervals of one week to several months. In addition, loss and gain measurements on sections of the office suspected of being in trouble will be made. For all general tests except equalization line up, point by point measuring equipment is provided, consisting of a 50 to 10,000-ke oscillator, the tuned transmission measuring set referred to above, a milliwatt power meter accurate to  $\pm 0.035$  db and a complement of attenuators, pads and comparison switches.



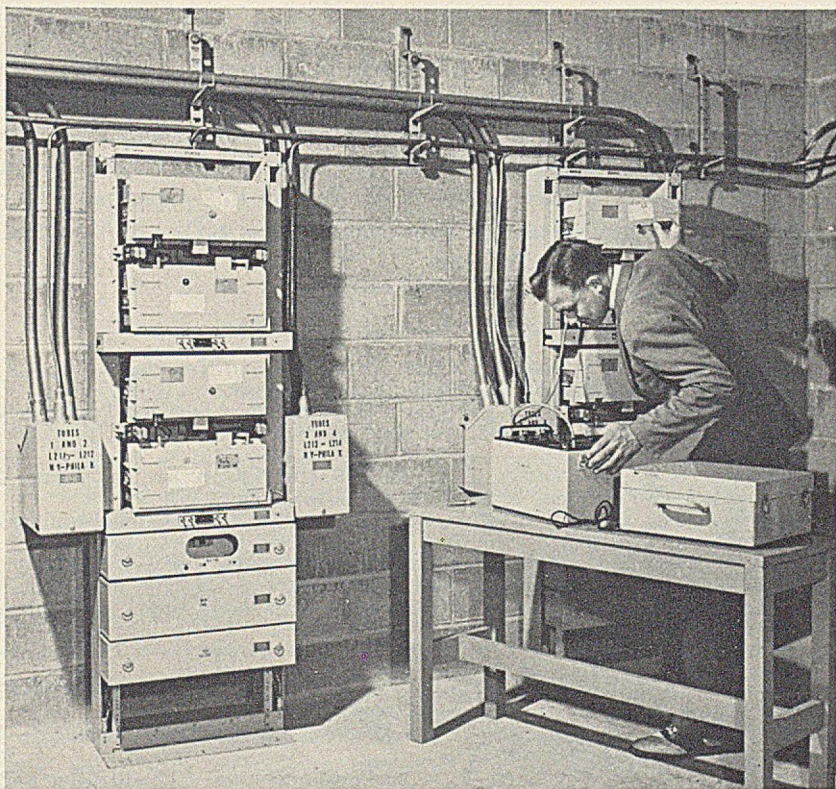

Fig. 23 — An engineer testing pilot transmission in an L3 repeater hut.

The adjustment of the manual gain equalizers to an accuracy of  $\pm 0.02$  db in a rapid and direct way is accomplished by special equipment described in the companion equalization paper.<sup>10</sup> A visual gain and delay transmission measuring test set, capable of measuring gain to  $\pm 0.05$  db and delay to  $\pm 0.02$  microseconds, has been developed for observing the line performance and adjusting delay equalizers when the system is used for television.

A maintenance center is provided at about 200-mile intervals along the line to service the equipment removed from repeaters. At these points facilities are provided for the following: (1) electron tube testing; (2) regulator repair and adjustment; (3) transmission measurements on passive components; and (4) amplifier testing of sufficient scope to permit changing tubes and to determine whether an amplifier is suitable for further service in the line.



## ACKNOWLEDGEMENTS

A system as complex as the L3 system is the result of a large scale cooperative development effort involving many Departments in Bell Laboratories. More than a hundred engineers and technicians have contributed to the design over a period of seven years. In the system planning aspects of the development covered by this paper particular mention should be made of the large contributions of L. G. Abraham, C. H. Bidwell and S. E. Miller.

## BIBLIOGRAPHY

1. Abraham, L. G., Progress in Coaxial Telephone and Television Systems, Transactions of the A.I.E.E., **67**, pp. 1520-1527, 1948.
2. Crane, R. E., Dixon, J. T. and Huber, G. H., Frequency Division Techniques for a Coaxial Cable Network, Transactions of the A.I.E.E., **66**, pp. 1451-1459, 1947.
3. Holbrook, B. D., and Dixon, J. T., Load Rating Theory for Multichannel Amplifiers, Bell System Tech. J., **18**, pp. 624-644, Oct., 1939.
4. Bennett, W. R., Cross-Modulation Requirements on Multichannel Amplifiers Below Overload, Bell System Tech. J., **19**, pp. 587-610, Oct., 1940.
5. Mertz, Pierre, Data on Random Noise Requirements for Theater Television, S.M.P.T.E., J., **57**, pp. 89-107, Aug., 1951.
6. Baldwin, M. W. Jr., The Subjective Sharpness of Simulated Television Images, Bell System Tech. J., **19**, pp. 563-586, Oct., 1940.
7. Baldwin, M. W. Jr., Single Frequency Video Interference Data, Proceedings of the J.T.A.C., Annex 8, **2**, Dec., 1948.
8. Morris, L. H., Lovell, G. H., and Dickinson, F. R., The L3 Coaxial System — Amplifiers, see pp. 879-914 of this issue.
9. Rieke, J. W., and Graham, R. S., The L3 Coaxial System — Television Terminals, see pp. 915-942 of this issue.
10. Ketchledge, R. W., and Finch, T. R. L3 Coaxial System — Equalization and Regulation, see pp. 833-878 of this issue.
11. Mertz, Pierre, Fowler, A. D., and Christopher, H. N., Quality Rating of Television Images, I.R.E., Proc., **38**, pp. 1269-1283, Nov., 1950.
12. Dodge, H. F., Kruger, M. K., and Kinsburg, B. J., The L3 Coaxial System — Quality Control Requirements, see pp. 943-968 of this issue.



# The L3 Coaxial System

## Equalization and Regulation

By R. W. KETCHLEDGE and T. R. FINCH

(Manuscript received April 17, 1953)

*The equalization and regulation problems of the L3 system are described and a theory of equalization of complex systems is outlined. The location and function of the various equalizers are explained including the roles and design of the various fixed, dynamic and manual equalizer networks. The analog computer used in the regulation system is described together with the cosine-equalizer adjusting technique used with manual equalizers. Finally the circuits and operation of the regulation system and its components are presented.*

### INTRODUCTION

Equalization is the process of correcting system gain and delay deviations sufficiently to permit the satisfactory transmission of signals. Regulation refers to that part of equalization which, by automatic means, corrects for relatively rapid changes in transmission. In the L3 coaxial system the transmission of television signals through more than 1,000 amplifiers introduces relatively severe equalization and regulation problems. Compared to the L1 system, the L3 system has nearly three times the bandwidth and over three times more stringent transmission objectives. Thus it has been necessary to devote considerable effort towards finding equalization methods that yield practical and economical solutions.

In previous systems it has often been the practice to design the bulk of the equalization system after the completion of an initial installation and the determination of the deviation characteristics of the system. In order to expedite the introduction of the L3 system into the field, equalization study and planning were initiated at the very beginning of the development of the system. One of the design methods was to make highly detailed studies using relatively inadequate data in order to find the major problems. As the data improved the studies were likewise



improved. While on the surface it might appear more practical to defer this work until the data are more adequate it has been found that these speculative studies are the only sure guide to ever getting the right data. Faced with such a complicated problem it is difficult to select from the vast amounts of things that might be important those relatively few items on which success or failure depends. In the L3 system there have been a number of critical problems which required intensive effort to find acceptable solutions, for example, the design of stable regulators to permit operation of 700 regulators in tandem, the choice of shapes for manual and dynamic equalizers and the selection of equalizer adjustment methods.

The design of equalization for the L3 system is not yet complete since the dynamic equalizer shapes are still subject to considerable uncertainty and the details of some of the final television mop-up equalization are yet to be settled. However no major difficulties are anticipated in equalizing the telephone system to be installed from Philadelphia to Chicago during 1953. Although amplifiers having the final gain characteristic were operated in the trial line between New York and Philadelphia for the first time in November, 1952, it was immediately possible to transmit quite satisfactory television pictures over the 200-mile loop using existing equalizers. It therefore appears that equalization will not limit the rate of field installation of the L3 system.

#### THE PROBLEM

The 4,000-mile coaxial cable has a gain distortion of nearly 40,000 db between 0.3 and 8.5 mc. Although the amplifiers reduce the distortion to perhaps 200 db, (and 100 microseconds), they leave a residue characteristic that is considerably more difficult to equalize. Further it is necessary to deliver service to intermediate offices spaced on the average about 120 miles apart. This requires equalization of high precision at numerous intermediate points. A further problem is the variability of the transmission characteristic due to manufacturing deviations plus time and temperature changes. Also, gain distortion cannot be permitted to exceed about 5 db at any point in the line or the signal misalignment will result in degraded signal-to-noise ratios.<sup>1</sup>

The overall transmission objectives<sup>1</sup> are of the order of 0.25 db and 0.1 microsecond which, if allocated among the over 1,000 amplifiers, lead to rather unrealistic amplifier requirements. In fact, individual amplifiers do not always meet the 4,000-mile overall requirements. Thus it is the problem of the equalization designer to provide a mop-up sys-



tem that will permit attainment of the transmission objectives at all service points and at all times.

#### EQUALIZATION THEORY

One of the steps in the solution of the general problem has been to develop a "theory" of equalization. This theory merely applies information concepts to the equalization problem to determine what information is required, when it is needed and how it may best be used. This theory has stimulated the development of novel equalizer adjustment techniques and has been of assistance as a guide to the attack on the general problem.

In order to equalize a system the man or machine who is to perform the action must know what corrective steps are required, and for this he must have some kind of information as to the present state of the system and as to the desired state. Second, he must have the necessary tools to convert the system from its present state to the desired state. Consider the first problem, the determination of the corrective steps required. The problem is to determine what we need to know, when we need to know it and especially in what form we are able to utilize the information most efficiently.

We can assume we know the desired state of the system; which is usually a constant loss with constant delay over the frequency range of interest. As to the present state of the system we note that sufficient information can never be obtained to equalize a system perfectly because of the finite bandwidth of the system and because the system changes with time. This is not a new fact, nor apparently a very important fact, because the system need not be perfectly equalized for satisfactory transmission of signals. It leads, however, to the converse idea, which is important — namely, that out of this infinite amount of information regarding the state of the system one should collect only the minimum amount that is needed. This implies making no more measurements of the state of the system than are absolutely necessary to perform the correction to a degree permitting satisfactory transmittal of the signals. The main purpose of this is, of course, to economize on time and effort required to obtain information, but it should be noted that excess information may be a source of confusion to the equalization operator.

To put this in the form of a rule, we have:

#### *Rule I*

*Collect only that minimum of information as to the state of the system as will permit equalization to the required degree for satisfactory transmission of the signals.*



Having established that a minimum of information should be collected, we return to the time variation of the system, which in theory can make the information obsolete before it can be used. However, without yet bringing in the practical fact that its most rapid rate is relatively slow, we should introduce the fact that the ways in which the system can vary at its most rapid rate are quite restricted as compared with the manner in which it can vary at slower rates, and we note that even these are relatively limited. (This probably applies to most transmission systems, not just to the L3 coaxial.)

Thus while the information regarding the more rapid, but simple changes must be collected more frequently it consists of a small amount of information per sample; whereas the information regarding the slow (but more complex) changes need not be collected very often, but it represents a relatively large amount of information per sample. Since the total rate of information collection is proportional to the information per sample times the rate of sampling, the minimum information collection principle would say that the rate of sampling should also be held to a minimum.

This demonstrates the value of association of particular types of system change with the rate and amount of their variation, because one may thus eliminate from the more rapid sampling the collection of information about changes that occur at slow rates. Furthermore, one may establish the sampling rates for the various system effects at the lowest possible value. (There is also a very practical value in knowing the rates and amounts of the various deviations, because system misalignment requirements force the equalization to be suitably distributed along the line.)

In the form of a rule, this is:

### *Rule II*

*To the greatest practicable extent the overall system behavior should be separated into individual effects each having its own time rate of occurrence and corrections should be made for each effect at the minimum tolerable rate for each.*

It is of interest to note that, if we couple the logic of Rule II with the fact that the fastest changes (due to changes in the temperature of the repeater huts) take hours to become appreciable, we see that the continuous collection of information from continuous pilots (and the continuous correction by pilot-controlled regulators) is in principle unnecessary and inefficient — except, of course, for its other function of giving alarms under trouble conditions.



The technical problem of determining the equalization states of the system is normally solved by sending some kind of signals over the system and observing the effect of the system on those signals. The raw data are usually in the form of loss and delay as a function of frequency. On the basis of these data, the equalization operator desires to correct the system by means of some equalizers which have adjustable transmissions and delays as a function of frequency. Thus the operator has a group of controls to be operated plus some data which has encoded in it the information as to the proper adjustment of each control. From these data, and a knowledge of the effect of each control, the operator must suitably compute the proper adjustments. As this may be too complicated a process to attempt on a trial and error basis, (or by numerical methods), it is quite an obvious advantage to the operator to receive the data as to the state of the system, not in its original form, but in the form of the necessary adjustments to his equalizer controls. This new form of the data simply represents a decoding process based on the available controls. An operator with the same data, but different and perhaps more complicated equalizers, would need the data in a form suited to his different equalizers.

Consequently:

#### *Rule IIIa*

*The information as to the state of the system may best be presented to the equalization operator in the form of the necessary adjustments of the available equalization controls.*

This rule has a closely related corollary which is based on the fact that the available equalization controls determine the amount of information that is needed. For example, if the independent gain equalization controls are " $n$ " in number, measurement of the gain of the system at " $n$ " suitably chosen frequencies is sufficient to determine the settings. (If the controls are not independent, fewer than " $n$ " frequencies need be measured.) This is, of course, a restatement of the fact that " $n$ " unknowns may be determined by solution of " $n$ " independent simultaneous equations. The unknowns are the equalizer settings and the simultaneous equations are the relationships of the shapes controlled by each equalizer to the total system error.

Thus:

#### *Rule IIIb*

*In general, the necessary and sufficient condition for the determination of " $n$ " independent equalization control settings is the knowledge of the system's*



*equalization error at "n" independent frequencies plus the knowledge of the effect of each of the "n" controls at each of the "n" frequencies.*

It should be noted that this statement of the rule assumes analysis by frequency rather than by transient behavior. This approach is used because, at present, equalizers are usually designed on a frequency characteristic basis. The validity of the rule is however more general.

From these two rules we can derive another regarding the minimum information principle that is similar to Rule I but is actually quite independent of it.

#### *Rule IV*

*No more information should be gathered from the system than is necessary to provide sufficiently accurate control setting information for the equalization operator.*

In this case the superfluous information may actually cause confusion or harm. It will, at the very least, confuse a manual operator to know of an error he is powerless to correct, whereas a mechanized system, on the other hand, would probably go berserk if it obtained too much information.

It is evident that the minimum amount of information that would be obtained in accordance with Rule IV would be the same as that obtained in accordance with Rule I only if the design of the equalization were optimum, because then the equalizer shapes (and the number of shapes) would just suffice to permit satisfactory transmission of the signals.

Up to this point we have determined in general what information is needed, when it is needed and the optimum form of its presentation. Now let us proceed to examine what to do with the data; which involves the nature of the equalization operator as well as his equalization tools.

If we followed Rule II rigorously, we should have several different type of controls; one for each of the effects having different time rates of occurrence. For purposes of illustration, however, we need assume only two rates — one quite rapid and the other very slow. It will be postulated here that very rapid equalization operations are most economically performed by machine. such as for example, the automatic regulation for cable temperature variations. Likewise relatively infrequent adjustment will be assumed to be best performed by a suitably informed human operator.

The first principle to note is that the only real distinction here is the rate at which data should be refreshed and acted upon. In either case



the data should be in the same form; a set of numbers (or their equivalent) representing equalizer changes.

Probably the most useful result of this theory of equalization has been the conclusion that mechanization of the equalization process, particularly in regards to computational techniques, permits substitution of simple logical methods for inefficient trial-and-error adjustment processes. This led to the use of an analog computer in the regulation system and, for manual equalizers, the development of measuring circuits that read directly in terms of equalizer adjustment error.

## EQUALIZATION

### LOCATION AND FUNCTION OF EQUALIZERS

The location of equalizers in the L3 system when only telephone is transmitted is shown in Fig. 1(a). Combined telephone-television equalization is shown on Fig. 1(b). When telephone and combined systems use the same spare line, that line is equipped for television. The general features of the main-repeater layout have been described in a companion paper.<sup>1</sup> The detailed layout of equalization is designed to meet the requirements of both telephone and television service and the need for flexibility in television network arrangements. In addition, switching of telephone or television service to a spare line must not appreciably degrade service.

Switching sections longer than 120 miles must be provided with an intermediate step of equalization to prevent excessive signal misalign-

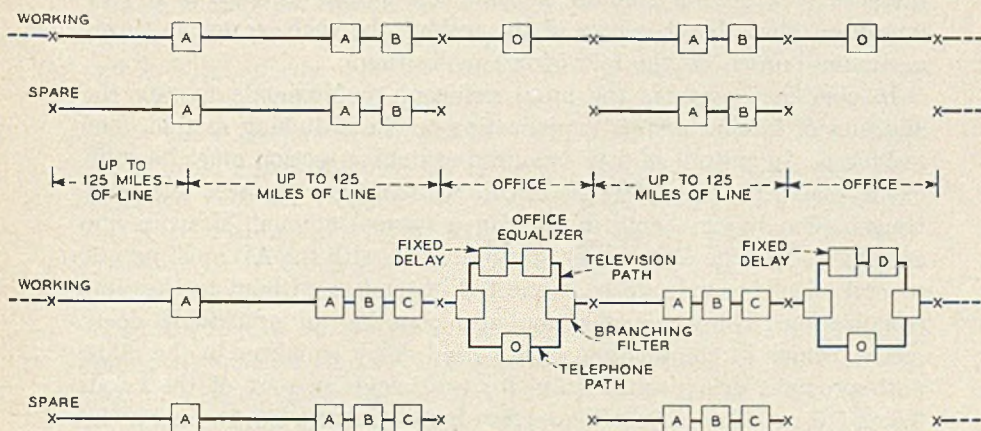

Fig. 1 — Typical equalizer locations in (a) telephone and (b) combined systems.



ment. This intermediate point is referred to as an equalizing auxiliary repeater. It is provided with the so-called A equalizer consisting in turn of fixed, manual and automatic gain equalizers. It reduces the gain error to less than 0.5 db using the fixed and manual sections and prevents appreciable degradation of this residue during an ensuing three month period by the action of three "office" regulators using pilots at 308, 2,064, and 7,266 kc controlling three regulating networks. One of these networks is the  $\sqrt{f}$  shape of the receiving amplifier.<sup>2</sup> The other two are first order corrections for vacuum tube aging and repeater temperature changes.

At offices, (switching main repeaters), on telephone systems further equalization is required to permit line switching of telephone channels and special service signals such as telegraph. Also it is not practical to provide telephone equalization on a cumulative basis over longer links than a switching link because of frogging and dropping.<sup>1</sup> No telephone channel rides for more than 800 miles in the same frequency location and dropping breaks up the pattern still further. Thus, for telephone, the switching links, which may number between 30 and 40 in a long system, are independently equalized.

The B equalizer contains manual and automatic sections, the latter being three regulating networks omitted in the A equalizer. Thus an A plus a B forms the final telephone equalization. The residue of five, independently-adjusted AB links must meet telephone requirements without frogging and 30 to 40 links must meet these requirements with 800-mile frogging. This performance must continue to be met in the presence of a normal amount of spare line switching. Also it is very important that the character of the residues be such as not to throw an undue burden on the television equalization.

In combined systems the more stringent requirements require the addition of further manual equalization to the switching section. The residue at the output of a C equalized switching section must be sufficiently small that a 4,000-mile circuit will continue to meet television transmission requirements in spite of a normal amount of spare line switching. Also the C equalizer in conjunction with the AB must permit several switching links to be connected in tandem without further line equalization. The C equalization also contains an adjustable delay section which in conjunction with a fixed delay equalizer in the office path provides delay equalization for the television part of the band, 3.6 to 8.5 mc. This adjustable section builds out the line to match the fixed unit.

The A-B-C pattern is for equalization of individual switching lines



and these equalizers are adjusted on a single switching link basis. On the office side of the switches are system components that also require equalization. In the telephone system these include such things as office cabling and hybrid coils. Also there is an office flat loss of nearly 30 db. Thus the lines are, in effect, operated to give a 30 db gain while the offices give a 30 db loss. Aside from the flat losses there are distortion shapes but fortunately these are all well approximated by a  $\sqrt{f}$  shape and a single manually adjustable  $\sqrt{f}$  equalizer plus suitable choice of flat loss provides adequate telephone office equalization. This is referred to as the O equalizer. It is adjusted to make the particular office have a flat characteristic.

In the office circuits of combined systems are branching filters to separate the telephone and television bands. The O equalizer is reused in the telephone path. The television path includes the fixed delay equalizer and a manual gain equalizer to correct for office cables, hybrids etc. After the tandem combination of several independently equalized lines and offices further equalization will be required. This will be accomplished by a multi-control manual D equalizer, having both gain and delay sections, inserted in the television only path at approximately 400-mile intervals. These D equalizers will be used to form 800-mile pilot links which are independently equalized to a degree permitting putting any five such links in tandem to form a 4,000-mile circuit without further equalization.

#### FIXED EQUALIZERS

The line amplifier can properly be considered as the first step of fixed equalization.<sup>2</sup> Also acting at this same level are artificial cable networks used to build out the repeater spacing to  $4 \pm 0.2$  miles, as well as the basic equalizer of the amplifier to take up differences between cable types. These devices are described in a companion paper.<sup>1</sup> The final step of fixed equalization is the so-called "design deviation equalizer" associated with all A equalizers. This equalizer comes in two versions, one for use with sections containing 23 to 32 repeaters and one for use in sections of 10 to 22 repeaters. In those few cases of less than 10 repeaters the fixed equalizer is omitted.

The function of the design deviation equalizer is, first, to correct for the design error of the average repeater and second, to recenter the manual (cosine) equalizers. Although the average repeater matches its four miles of cable to within  $\pm 0.12$  db this design error accumulates to over 3 db in 30 repeaters and further the shape is a difficult one to equalize. In order to keep the number of designs to a minimum only two sizes



are used, 19 and 28 repeaters, and the residue is corrected by the manual equalizers. This residue may be positive or negative depending on whether the fixed equalizer over or under compensates. Thus there is only a small tendency for these residues to accumulate in long systems. However the inaccuracies of match between the fixed equalizer and the gain of the average repeater section tend to accumulate systematically and must therefore be kept small. This brings out the importance of statistical quality control of amplifier manufacture<sup>2</sup> since any systematic shift in the amplifier gain characteristic will accumulate and may consume excessive manual equalizer range or may lead to excessive equalization errors. For example, a shift of only 0.05 db in the gain of the average amplifier would represent 1.5 db in 30 repeaters, 50.0 db in 1000 amplifiers and thereby becomes an extremely serious matter. Thus quality control of the amplifier is a vital part of the solving of the equalization problem.

The various effects that consume the range of the manual equalizers produce for some shapes an unsymmetrical consumption of range. If uncorrected this would produce larger range requirements in the manual equalizers as well as introduce new shapes to be equalized. The manual equalizer shapes are symmetrical and their errors cancel if equal amounts of positive and negative range occur in the system. Any systematic offset of a particular shape tends to introduce new shapes due to the manual equalizer networks themselves. By appropriate modification of the shape of the fixed equalizer it is possible to recenter the manual equalizers so that on the average the manual shapes are in the center of their range.

#### DYNAMIC EQUALIZERS

Any long transmission system suffers from relatively rapid gain changes and in the L3 coaxial system, as in many previous systems, the necessary corrections are performed automatically by pilot controlled regulators. Pilot tones are transmitted over the line at a reference level and, at appropriate points, regulators pick the pilots off the line, observe the deviation in pilot levels from the reference values and restore the pilots to or very nearly to the reference values by the use of regulating networks.

There are fundamentally two causes of fast gain changes, time and temperature. Time produces vacuum tube aging and in spite of their feedback the line amplifiers change gain. In one week a 4,000-mile system is expected to change by as much as 5 db due to the aging of the 6000 tubes or so in the transmission path. Because of different thermal



characteristics, temperature affects cable and repeaters semi-independently. In a 4,000-mile system one week is expected to engender as much as 8 db gain change by change in repeater temperature. Cable changes can exceed 100 db per week. Thus these effects must be corrected to a very high order of precision to maintain good television or telephone service.

These gain changes are not the entire story; when the gain changes in the band it also changes outside the band and usually by an even larger amount. Thus equalization of the in-band gain leaves outband (above 8.5 mc) gain changes which produce in-band delay changes of several microseconds. Because of the difficulty and complication of providing automatic delay equalization it is necessary to equalize these delay changes on a gain basis, by at least partial correction for outband gain changes. Further, since satisfactory pilot transmission is possible only within the band, these out-band changes must be predicted from the in-band gain changes. This effect, in itself, indicates the use of equalizers whose individual shapes are those produced by specific system causes producing a correlated change in many elements. Thus building the regulating networks to match the effects of the individual system causes and matching to 10 or 12 mc rather than just to 8.5 mc permits simultaneous gain and delay equalization. Such a set of shapes is also more accurate because it is matched to the special ways in which the specific system can change rapidly.

In theory the regulating networks could be built to match linear combinations of the cause shapes but there are two difficulties. First, not all of the cause shapes are known accurately or often even roughly at the introduction of a new system into the field. The mixtures of shapes cannot be determined without the missing ingredients. Second, a system is not a static design. Experience suggests improvements and thus occasions will arise where one will want to change the correction for a particular cause. If the networks represent mixtures of the causes this necessitates changing all the networks. If specific networks match specific causes only the appropriate network needs replacement.

### *The Computer*

The use of cause shapes leads to a problem to which the computer provides the solution. These cause shapes are broad effects covering the entire band and more. Thus no one pilot is a measure of a specific cause. However by a process equivalent to the solution of simultaneous equations the pilots determine the amounts of an equal number of cause shapes that will restore the pilots to normal. Thus the computer trans-



lates pilot errors into shape errors and drives the appropriate regulating networks to obtain the corrections.

Let the equalizer shapes be given by functions of the form

$$S_n(f) = k_n F_n(f), \quad (1)$$

where "n" is the subscript number identifying the particular equalizer.

(The capital "N" is reserved for the total number of equalizers.)

" $F_n(f)$ " is the equalizer shape (on a "unit basis") as a function of the frequency " $f$ ".

" $k_n$ " is the amount of shape introduced by adjustment, " $k_n$ " may be positive or negative.

" $S_n(f)$ " is the resultant shape put in the system by adjusting  $F_n(f)$  by an amount  $k_n$ .

The total shape introduced by all "N" equalizers is obviously;

$$S_{\text{total}}(f) = \sum_{n=1}^{n=N} S_n(f) = \sum_{n=1}^{n=N} k_n F_n(f). \quad (2)$$

To obtain a match of  $S_{\text{total}}$  to the given equalization error,  $S_{\text{given}}$ , at "M" frequencies from  $m = 1$  to  $m = M$ , requires that;

$$S_{\text{total}}(f_m) = S_{\text{given}}(f_m). \quad (3)$$

at each frequency from  $f_1$  to  $f_M$ . Or, in terms of equation (2)

$$S_{\text{given}}(f_m) = \sum_{n=1}^{n=N} k_n F_n(f_m) \quad (4)$$

again, at each frequency from  $f_1$  to  $f_M$ .

All of the important conclusions regarding the action of an equalization computer are implicit in the "M" equations indicated by equation (4).

Consider a case where there are three shapes. Let the information as to the difference between the system state and its desired state be determined by the deviation of three pilot levels which are observed to be  $\delta_1$ ,  $\delta_2$  and  $\delta_3$  at the pilot frequencies  $f_1$ ,  $f_2$  and  $f_3$ . The problem is to find the values of  $k_1$ ,  $k_2$  and  $k_3$  that will give a match at these frequencies. This means that the following equations must be satisfied:

$$S_1(f_1) + S_2(f_1) + S_3(f_1) = \delta_1 \quad (5)$$

$$S_1(f_2) + S_2(f_2) + S_3(f_2) = \delta_2 \quad (6)$$

$$S_1(f_3) + S_2(f_3) + S_3(f_3) = \delta_3 \quad (7)$$



Thus

$$k_1 F_1(f_1) + k_2 F_2(f_1) + k_3 F_3(f_1) = \delta_1 \quad (8)$$

$$k_1 F_1(f_2) + k_2 F_2(f_2) + k_3 F_3(f_2) = \delta_2 \quad (9)$$

$$k_1 F_1(f_3) + k_2 F_2(f_3) + k_3 F_3(f_3) = \delta_3 \quad (10)$$

The solutions for  $k_1$ ,  $k_2$  and  $k_3$  take the form

$$k_n = a\delta_1 + b\delta_2 + c\delta_3, \quad (11)$$

where  $a$ ,  $b$  and  $c$  depend solely on the shapes  $F_m(f)$ .

Thus the values of the  $\delta$ 's may be decoded into the values of the equivalent  $k$ 's by the simple process of multiplying each " $\delta$ " by some fraction that is a function of the equalizer shapes; or, more precisely, by a fraction that is a function of the values of the various shapes at the frequencies  $f_1$ ,  $f_2$ , etc.

The circuit of the computer is quite simple; consisting of about  $N^2$  resistors for the control of " $N$ " networks by the deviations that are measured at  $M = N$  pilot frequencies. This simplicity is valuable for its own sake, but, as previously noted, there is considerable value in the fact that substitution of new equalizer shapes requires only that changes be made in the values of some of the resistors.

Fig. 2 illustrates the principle by showing the computer circuit required for the previous example of three shapes for which information is given at three frequencies,  $f_1$ ,  $f_2$  and  $f_3$ . The three dc voltages representing the deviations  $\delta_1$ ,  $\delta_2$  and  $\delta_3$  are decoded by simply cross-connecting them to the three pairs of output terminals through fixed resistors chosen to satisfy the relationships of equations (8), (9) and (10). The output voltages will be proportional to the desired equalizer correction quantities  $k_1$ ,  $k_2$  and  $k_3$ .

In general the calculation of some of these resistors will give negative values. Thus it will generally be necessary to require that the dc voltages representing the errors  $\delta_1$ ,  $\delta_2$ , etc., be available in both polarities. Alternately, the errors can be provided in only one polarity and the circuits to which the computer outputs connect can provide the push-pull circuit. This latter course has been used in the L3 regulators as indicated on Fig. 2.

The effect of using the computer is as follows. If one pilot changes, all regulating networks correct but in such proportions and polarities as to produce no gain change at any pilot frequency except at the one originally disturbed. If all pilots deviate in proportions corresponding



to one of the shapes, no network corrects except the one corresponding to the original pattern of pilot deviation.

If conventional regulator circuits were used with particular pilots assigned to particular shapes the interactions would be intolerable. Thus the computer removes the restrictions on the choice of shapes imposed by regulator interactions. In turn this permits freedom in changing shapes as system data improves. It is important to provide the initial equalizers before adequate data on the system are available. As the system grows in length the equalization must be improved but the data improves also. Thus there is an economic benefit in providing a flexible equalization plan which allows the earliest possible commercial use of the system.

### *Dynamic Equalizer Requirements*

Because temperature and aging variations can result in both gain and loss variation with respect to the average transmission, the equalizers must be capable of inserting both loss and gain compensation. Also, it is extremely desirable that equal gain and loss settings for the equalizer result in symmetrical transmission characteristics with respect to the average. In a long transmission system, some of the sections will insert excess gain and others, excess loss. If the equalizer gain and loss characteristics are symmetrical, the residue will be related to the system

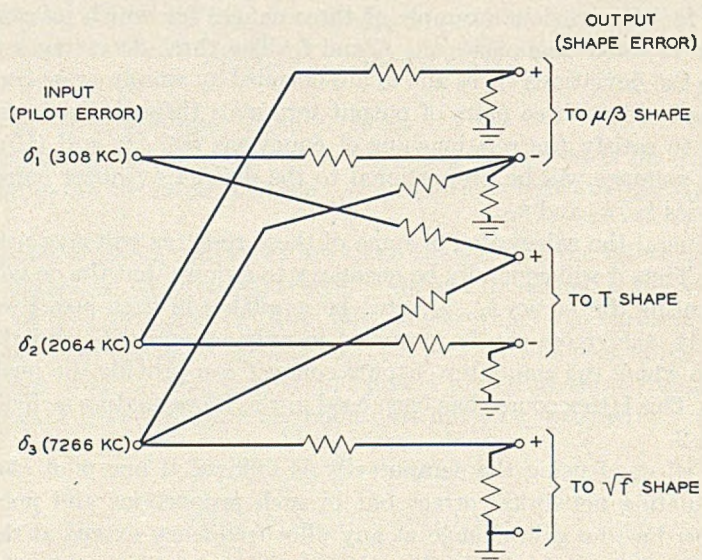

Fig. 2 — Schematic of regulation system computer.



deviation and some constant part of the equalizer characteristics. If this is not the case the residues can produce new variable deviations shapes and thereby lead to increased complexity in following stages of equalization.

As previously described, equalization of both gain and loss is required and this implies active equalizers. Although a number of methods were studied, noise and modulation requirements led the L3 system to the so-called "block of gain-block of loss" design. The equalizers are passive networks and in order to realize both gain and loss adjustability, the normal setting loss must at least equal the total amount of gain adjustment. The various equalizers are combined into two to four groups whose loss is compensated by corresponding numbers of flat gain amplifiers.<sup>2</sup>

The required number of such blocks of loss and gain depends upon the amount of system gain variation to be equalized. The determination of the shapes and magnitudes of system variations is an important system problem. Large amounts of study are necessary in order to evaluate the system sensitivity to various changes; the determination of the magnitude of these causes, such as temperature variation, aging rates, etc.; and the determination of maintenance intervals that provide an economic balance between maintenance expense and system cost. These must be studied in detail to provide the equalizer designer with shape and range data for his dynamic equalizer designs. The equalization characteristics and maximum ranges for the two most important dynamic equalizers aside from cable temperature, namely, repeater temperature (T) and vacuum tube aging  $\mu\beta$  are shown on Fig. 3. In order to maintain satisfactory transmission during a maintenance interval, the dynamic equalizers must be able to match any characteristic within the maximum ranges and throughout the transmission band to within 1 to 2 per cent. As noted previously the necessity for simultaneous delay equalization requires the dynamic networks to also make at least an approximate correction in the out-band region. This is shown on Fig. 4.

The control element in the equalizers is a thermistor whose available resistance range is 30 to 1050 ohms. ( $\sqrt{f}$  of line amplifier<sup>1, 2</sup> 125 to 2000 ohms). Thus the regulation ranges shown in Fig. 3 are realized using this one variable resistance element in each equalizer.

The following is a summary of the dynamic equalizer requirements.

1. Provide symmetry in regulation characteristic.
2. Minimize flat loss.
3. Match prescribed gain variation to a high degree of accuracy within transmission band.



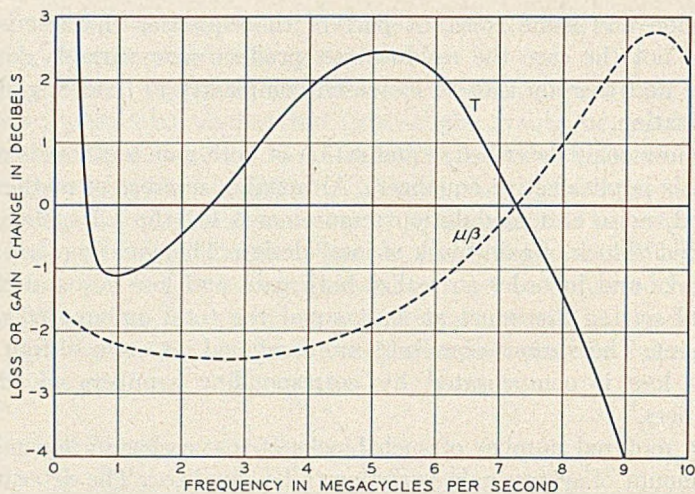

Fig. 3 — Regulation shapes and ranges for tube aging ( $\mu\beta$ ) and repeater temperature (T). The curves given can occur as either gain or loss and apply to 30 repeaters.

4. Provide satisfactory equalization of in-band delay distortion due to out-band gain change.
5. Each equalizer controlled by a single variable resistance element.
6. The desired performance to be realized in 75-ohm circuits.

#### Dynamic Equalizer Design

The design used is the structure commonly known as the Bode Regulator,<sup>3, 4</sup> and shown in block schematic form in Fig. 5. An ideal regulating

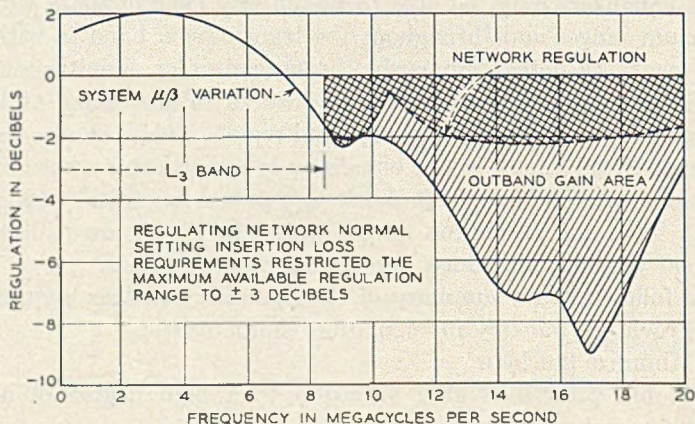

Fig. 4 — Match to out-band gain change to reduce in-band delay distortion.



network would insert a deviation characteristic

$$\theta = f(R_T) \cdot f(\omega) \text{ db.} \quad (12)$$

Such a network would yield a given shape independent of setting and thus would have linearity as well as symmetry. Actually the Bode network has symmetry but only approximates linearity. As shown, it may be designed to insert a variable impedance either in series or in shunt with the line. When using only one control element it is not a constant resistance structure and must be operated between terminations of the design value. The choice of series or shunt configuration was governed for L3 by the fact that very low thermistor resistance would require excessive dc currents from the regulators. For a 75-ohm circuit and this thermistor limitation the series regulator provides lower normal-setting loss.

The insertion gain for the series regulator may be written as:

$$\theta = \theta_N + 2 \text{ arc tanh} \left[ \frac{R_1 - R}{R_1 + R} \cdot \rho e^{-2\tau} \right], \quad (13)$$

where  $\theta_N$  = The normal setting flat loss as given by

$$\alpha_N = 20 \log \frac{R_1}{R} \text{ decibels.} \quad (14)$$

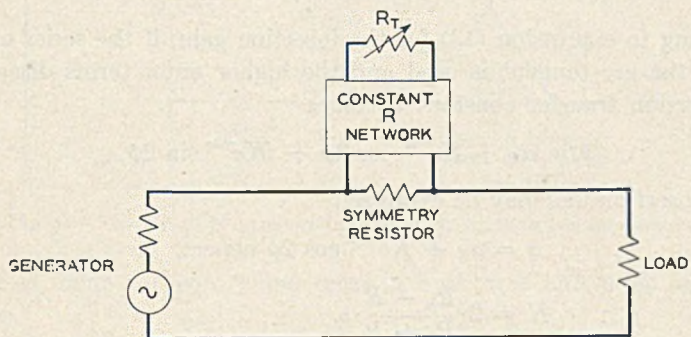

(a) SERIES TYPE

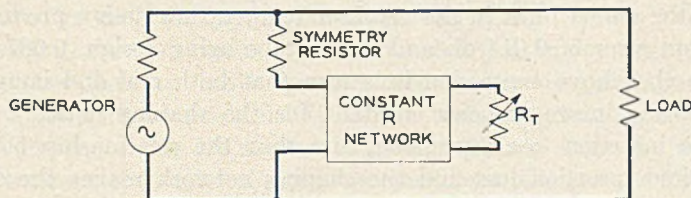

(b) SHUNT TYPE

Fig. 5 — Block diagram of Bode Regulating Network.



$R_1$  is the symmetry determining resistor and is in parallel with the input terminals of the shaping network in order to limit the maximum value of the series impedance. The equation of symmetry may be expressed as

$$R_1^2 = \left(1 + \frac{R_1}{2R_0}\right)R^2. \quad (15)$$

$R$  is the image impedance of the shaping network. The thermistor has this value at its normal setting.

$R_0$  is the impedance of the circuit in which the regulator is inserted, in this case, 75 ohms.

$\rho$  is the reflection factor between the network impedance,  $R$ , and the thermistor impedance,  $R_T$  and is given by

$$\rho = \frac{R_T - R}{R_T + R}. \quad (16)$$

$\Gamma$  is the image transfer constant of the shaping network and may be expressed as

$$\Gamma = \sigma + i\psi. \quad (17)$$

Returning to expression (13) for the insertion gain, if the series expansion of the arc tangent is used and the higher order terms discarded, the insertion transfer constant becomes

$$\theta = \alpha_N + Ke^{-2\sigma} \cos 2\psi + iKe^{-2\sigma} \sin 2\psi, \quad (18)$$

or the insertion loss may be expressed

$$\alpha = \alpha_N + Ke^{-2\sigma} \cos 2\psi \text{ nepers}, \quad (19)$$

$$K = 2 \cdot \frac{R_1 - R}{R_1 + R} \cdot \rho. \quad (20)$$

This approximation is valid for design purposes if the regulation range is not too large or the accuracy required too great. For example, omission of the cubed term in the repeater temperature design produced a maximum error of 0.014 db and in the tube aging design, 0.007 db.

From the above expression it is seen that both real and imaginary parts of the image transfer constant for the shaping network enter into the insertion loss expression, and thus the relationship between the desired insertion loss and the shaping network makes the design process difficult. At this stage in the design considerable art and ingenuity is required in order to continue the design efficiently. The ap-



proach taken depends upon the regulation characteristic desired and the experience of the designer. Since both loss and phase are involved, familiarity with loss-phase relations is important. After a design has been blocked out, repeated modifications of the network parameters usually indicate the adequacy of the configuration chosen. Usually several sections in tandem are required in the shaping network in order to obtain precision of match, and some of these most likely will be all pass sections in order to control the phase  $\psi$  independently of the real part  $\sigma$ . It may be noted that at cross over points in the regulation characteristic, i.e., zero regulation, either the phase  $\psi$  has to be 45 degrees, or odd multiples thereof, or the loss  $\sigma$  has to be infinite. Usually the

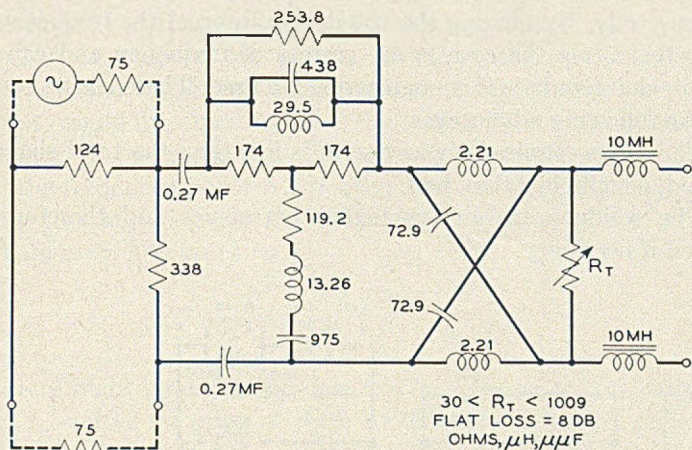

Fig. 6 — Circuit of the regulating network for repeater temperature.

phase is made the controlling term in both zero and peak regulation points.

The designs presently used on the L3 system for the repeater temperature and tube aging equalizer are shown in schematic form on Figs. 6 and 7. The 0.27 microfarad capacitors and 10-millihenry inductors are employed in order to supply the dc heating current to the thermistor. The shunt resistors placed across the 75-ohm line, in one case 124 ohms and in the other case 133.4 ohms are used in order to make the left side driving point impedance equal 75 ohms at normal setting of the thermistor. These networks are used in cascade with the manually adjusted, constant resistance networks and it seemed desirable that the impedance characteristic of the dynamic equalizers be relatively good at one pair of terminals.



MANUAL GAIN EQUALIZERS

One of the more difficult equalization design choices is the selection of shapes for the manual equalizers. In the L1 system some of the shapes used were so-called "bump" shapes. This type of shape reduces the amount of shape overlap and thereby tends to reduce the adjustment problem when conventional adjustment methods are used. For the L3 system many types of shapes and circuits were carefully studied. The computational concepts of equalizer adjustment resulted in the consideration of shapes that would otherwise be impractical.

The shapes finally chosen for L3 are "cosine" shapes. Any continuous function may be matched over a 180-degree interval by a Fourier series of cosines only. By making the 180-degree interval the frequency range from 0 to 8.5 mc the cosines are cosines of frequency and can match any gain characteristic if enough terms are used. These cosine equalizers have the following advantages.

1. The range required for any term is less than the total shape to be matched, usually less than half.
2. The residues are always higher harmonics and therefore easily matched if necessary.

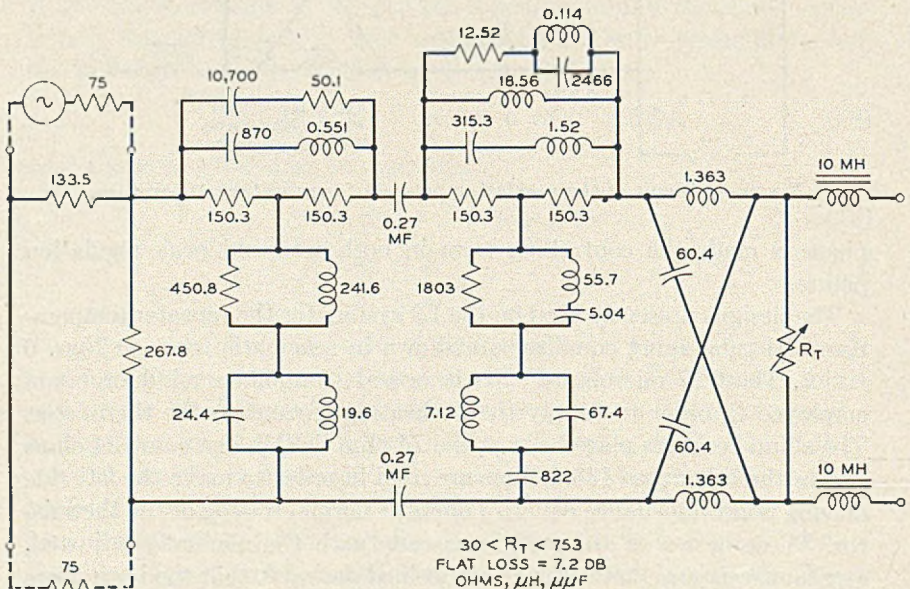

Fig. 7 — Circuit of the regulating network for tube aging.



3. The controls are easily adjusted using methods to be described.
4. If better equalization is required at any point the existing equalizer is retained, additional harmonic terms are added.
5. The major portions of the equalizers require only one value of inductance and two values of capacitance to form the delay lines used in the networks. This also assists in the application of distribution requirements.
6. The manual equalization can be designed with a minimum of information about the system characteristics.
7. The equalization is on a least square error basis rather than minimum peak error.

The networks used to realize these cosine shapes are constant resistance Bode regulating networks<sup>3</sup> employing second degree all-pass sections.<sup>5</sup> If the phase of the all-pass sections were made proportional to frequency, the transmission performance within the frequency band of interest would be that provided by a Fourier series composed of cosine terms in the variable  $\omega$ . By appropriate choice of the all-pass sections the frequency-phase relationship can be warped to give greater weighting to a specified portion of the frequency range. The phase of the all-pass section is given by

$$\psi = 2 \cot^{-1} \left[ \frac{b}{2} \left( \frac{f_c}{f} - \frac{f}{f_c} \right) \right]. \quad (21)$$

Small  $b$  and high  $f_c$  weights the low frequencies, the linear phase case  $b = 1.2$ ,  $f_c = 10.2$  mc gives uniform weighting and large  $b$  weights the high frequencies. A  $b = 2$ ,  $f_c = 13.75$  mc, was selected for the L3 equalizers because it weights somewhat the higher frequencies where the television signal is transmitted and second, each unbalanced bridge  $T$  network section can be constructed with only four elements, two like inductors and two capacitors. For  $b$ 's smaller than 2, coupling between the two like coils is required, and for  $b$ 's larger than 2, an additional element is required.

The all-pass networks are designed on a 75-ohm impedance level and thus the flat, normal setting of each regulating network is 4.18 db maximum. The 75-ohm level makes the series and shunt networks identical and also facilitates manufacturing testing. A special dual variable resistor is used as the control element. It has a resistance range of 15 to 375 ohms and provides a regulation range of  $\pm 2.78$  db maximum.

A schematic of this network is shown on Fig. 8. In the case of the 0 harmonic, flat gain, the phase sections are omitted. For the  $n$ th harmonic



term,  $n$  sections are used in both the series and shunt arms. The constant resistance structure permits the complete equalizer to be formed by a cascade of such networks without interaction effects. This provides a loss characteristic given by

$$\text{Loss} = k_0 + k_1 \cos 2\psi + k_2 \cos 4\psi + k_3 \cos 6\psi + \dots \quad (22)$$

where  $\psi$  is the phase of the individual all-pass section which goes from 0 to 90 degrees between 0 and 8.5 mc. The  $k$ 's are adjusted by means of the dual adjustable resistors. Note that each term of the series is represented by a corresponding equalizer.

Application of this mop-up polynomial to a large number of L3 deviation characteristics indicates that considerably less range than the maximum  $\pm 2.78$  db will be required for most of the cosine terms. Fig. 9 illustrates this convergence of the series for the eight largest amplifier manufacturing variations. This and other studies show that after the first three harmonics the range may be reduced. It can be shown,<sup>6</sup> for example, that if the system gain deviations are finite within the range of interest (interval of convergence) the coefficients of the approximating polynomial will decrease in magnitude linearly proportional to the number of the terms, that is, the  $n$ th coefficient will be smaller than some constant divided by  $n$ . If the deviation characteristics are continuous and hence have finite first derivatives, then the coefficients of the approximating polynomial will decrease as the square of

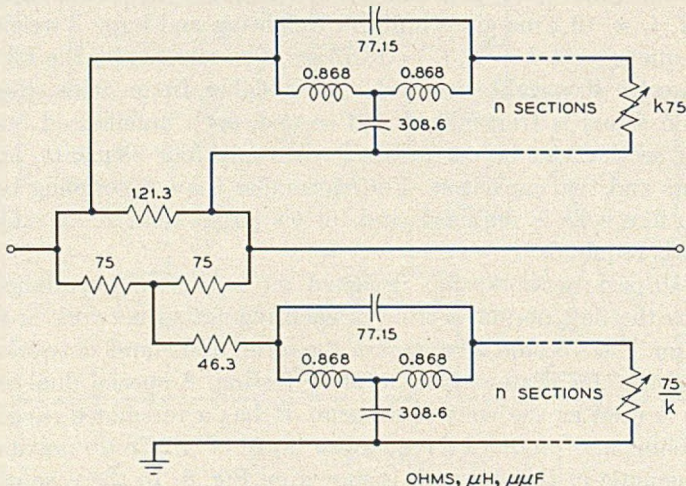

Fig. 8 — Circuit of a cosine equalizer without dissipation correction.



the number of the term. If all derivatives are finite the coefficients will decrease exponentially. This last case is believed to describe the convergence for at least most of the L3 system shapes. Thus for the high order terms that require little range it is possible to reduce the flat loss of the networks.

In order to reduce the flat loss without changes in the 75-ohm impedance level of the phase sections or in the dual adjustable resistors, pads are inserted between the resistance  $T$  and the all-pass sections. In this manner the loss could be reduced to 2.2 db for  $\pm 0.5$  db range if it were not for the dissipation in the all-pass sections. This dissipation is due to the coils and increases with frequency. It tends to produce a reduced cosine amplitude in the high frequency part of the band. To correct this effect, the pad mentioned above is actually made an equalizer section whose loss change with frequency corrects for the dissipation in the coils thereby yielding cosine amplitudes independent of frequency. The price of this is an increase of the flat loss to 3.4 db for  $\pm 0.5$  db range. The circuit of the term 10 network is shown on Fig. 10. The range

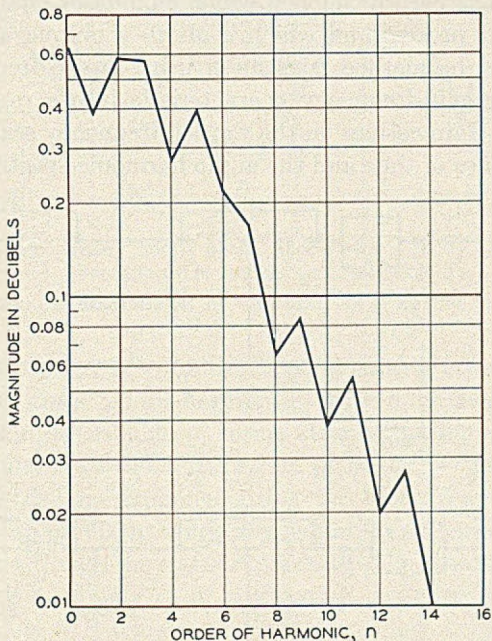

Fig. 9 — Range required for various cosine terms due to expected manufacturing variations of eight critical elements. The magnitudes are based on RSS addition in 25 repeaters.



of this term is  $\pm 0.5$  db as is that of all higher terms (to 24). Terms 1, 2, 3 have full range, 4, 5, 6 have 1.5 db and 7, 8, 9 have 1 db. The 0 term, flat gain, is also 1 db because additional flat shape is obtainable from the flat amplifiers used to make up for the equalizer loss.

The shapes provided by the first three terms are shown on Fig. 11. Note that the shapes are cosines of a warped frequency variable and that on this warped scale the shapes are orthogonal. In all, 24 such harmonics plus flat gain are used in the high frequency line for combined systems. For all telephone use only 14 harmonics plus flat gain are required. Fig. 12 shows the construction of one of the cosine networks. These are mounted in groups of five as indicated in Fig. 13. The fixed equalizer and regulating networks are mounted to the rear of the cosine assembly.

### *Harmonic Adjusting Set*

To make a mental harmonic analysis of a complicated gain characteristic is difficult if not impossible. Therefore a special cosine-equalizer adjusting set has been developed which eliminates trial and error from the adjustment process and which leads to a unique optimum adjustment. Broadly the method consists of using sweep frequency methods to convert the gain-frequency characteristic into a repetitive voltage-time function. Gain cosines on the warped frequency scale are converted to voltage cosines of time and the audio harmonic-spectrum components

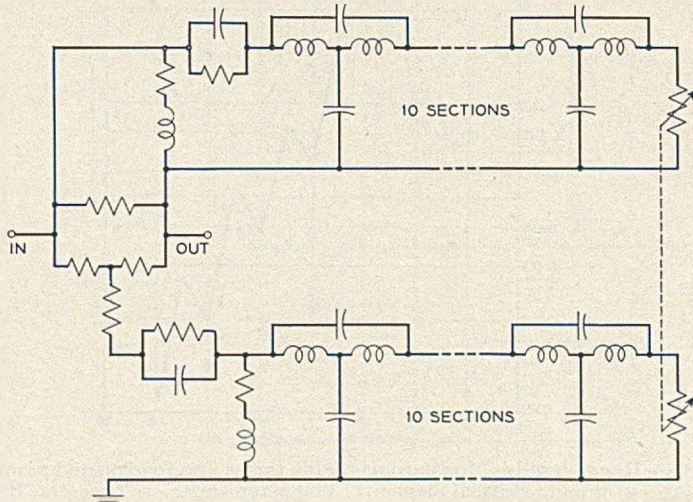

Fig. 10 — Cosine equalizer circuit (tenth harmonic) showing dissipation and range corrections.



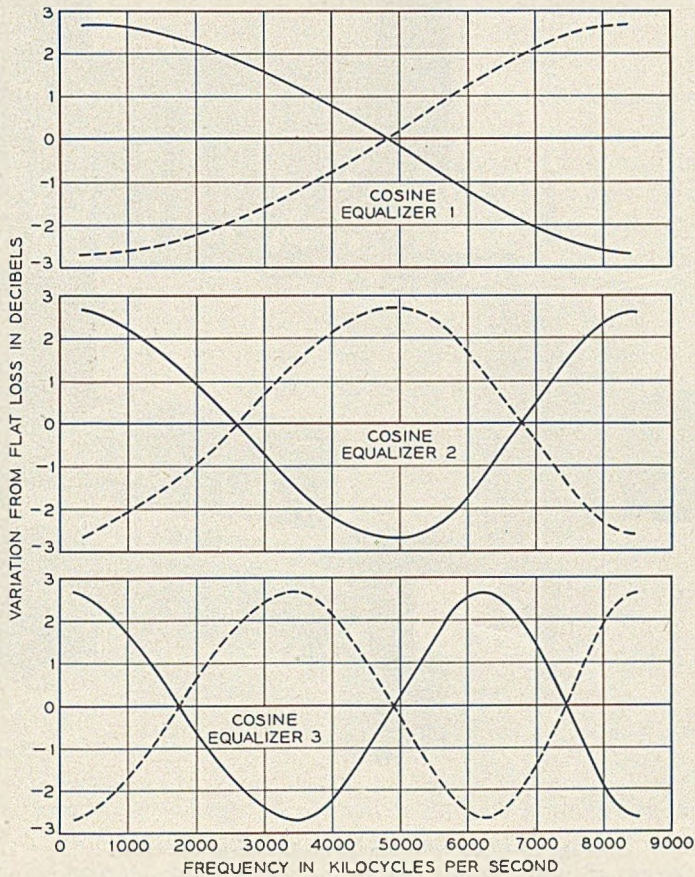

Fig. 11 — Shapes introduced by the first three cosine harmonics.

are individual measures of equalizer control-setting errors. By the adjustment process these audio harmonics are removed thus yielding a gain characteristic describable in terms of only the higher cosine components not available to the equalization operator.

The operation can be explained using the block diagram shown on Fig. 14. The sweep oscillator sends a constant level, variable frequency, over the line and through the cosine equalizer to the detector. The output of the detector on terminals x-x at any instant is a measure of the transmission of the line and equalizer at the frequency being sent by the sweep oscillator at that instant. The sweep frequency starts at zero and sweeps to 8.5 mc in a period  $t_1$ . As shown on Fig. 15 the frequency-time relationship is warped to correct for the warping of the equalizer



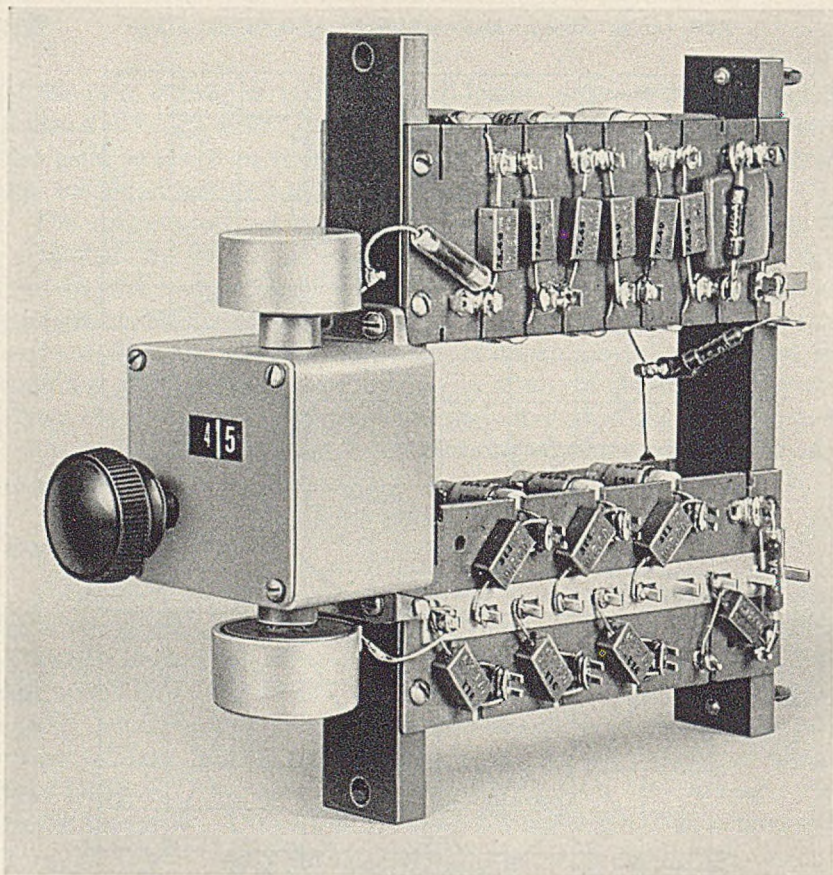

Fig. 12 — View of single cosine term network.

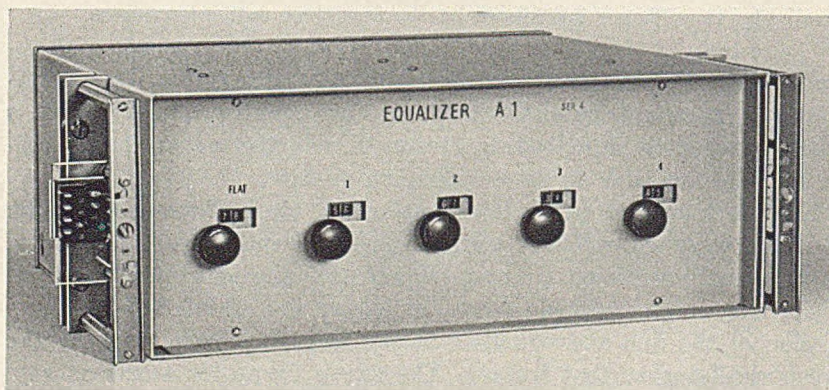

Fig. 13 — Assembly of five cosine terms. A "C" equalizer requires five of these assemblies, a "B" equalizer, three, and an "A", two.



phase-frequency relationship. The sweep oscillator therefore scans at a linear rate in cosine degrees vs time. Upon reaching 8.5 mc the sweep reverses and returns to zero. If the cosine shapes were linear cosines of frequency the sweep would be a triangular wave.

Assume that the line is perfectly equalized except that the first harmonic term is misadjusted. As the sweep goes from 0 to 8.5 mc the voltage at x-x follows the first harmonic curve of Fig. 16 from 0 to  $t_1$ . When the oscillator scans back to 0 the voltage at x-x follows the first harmonic curve from  $t_1$  to  $2t_1$ . Then the cycle repeats. The voltage at x-x thus becomes a pure cosine of time oscillation of frequency,  $\frac{1}{2}t_1$ . Although the equalizer shapes are actually cosine on a decibel rather than an amplitude basis this has little practical effect because for small deviations the two are nearly identical.

If instead of a first harmonic error the second or third cosine harmonic

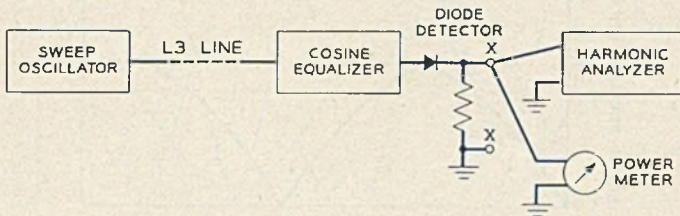

Fig. 14 — Block diagram showing the method used to adjust cosine or other orthogonal equalizers.

is misadjusted, the voltage at x-x will follow the appropriate curve of Fig. 16. The dc component measures the zero harmonic but in practice only the ac components are measured and the flat gain is set as a final step to make the pilot levels correct at the line output. If it takes 0.01 seconds for the oscillator to scan up and back, the first harmonic produces 100 cps output from the detector. The second harmonic equalizer produces 200 cps, the third 300 cps, etc. Therefore at the output of the detector there exist a set of audio frequency harmonics whose amplitudes are a measure of the equalization error of the setting of the cosine controls of corresponding periodicity.

These harmonics can be separated by convention filtering techniques, for example, by an audio tuned detector or harmonic analyzer as noted on Fig. 14. The analyzer can be tuned to 100 cps and the first harmonic control rotated to remove the 100 cps component. Then tuning to 200 cps the second control is operated, etc. This null method is similar to bridge balancing and may be instrumented to similar high precision. After all of the harmonics corresponding to equalizer controls have



been removed the process is complete and the equalization residue must be composed solely of those terms not provided by the equalizer.

The harmonic analyzer method requires tuning or switching and thus to simplify the method still further the actual field equipment uses a power indicator in place of the analyzer as noted on Fig. 14. Given a spectrum of signals of differing frequencies, removing any one reduces the total power. Therefore the entire spectrum may be applied to a power indicator and the reading reduced by adjusting the various equalizer controls. In practice this process is assisted by filtering out the high harmonics which cannot be equalized. This reduces the total power and increases the ease of reading the meter. While the method has been demonstrated using an ordinary 60 cps wattmeter, an electronic wattmeter is used in the field equipment.

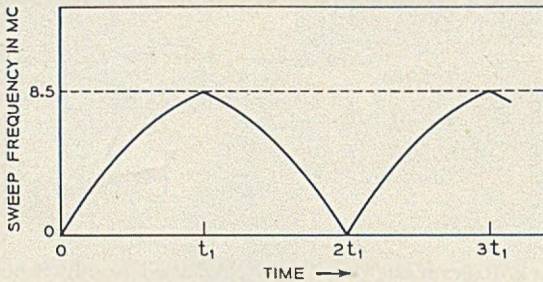

Fig. 15 — Method of scanning the system gain characteristic to convert cosines of frequency into cosines of time.

While the receiver unit can be quite simple, the sweep oscillator is complicated by such things as circuits to control the warping and to hold the sweep limits accurately. In practice the sweep is between 0.3 and 8.5 mc and is at a 37 eps rate. Further there are six pilots on the system and although the dynamic regulators at the adjusting point are paralyzed during the cosine adjustment the pilots to intermediate regulators must not be disturbed. Thus the sweep frequency is shifted very rapidly through the pilots. When the sweep frequency gets within about 25 kc of a pilot it is shifted suddenly to the other side of the pilot without producing transients in the receiver.

While other methods of cosine equalizer adjustment were tested and found to work satisfactorily, the above method was found to be superior. In addition, removal of the filtering permits the power meter to read the rms equalization error and thus the equalization operator can determine the quality of the job and observe whether the state of the line is



satisfactory. Also the power method is usable with sawtooth as well as triangular scanning and, further, works on any set of orthogonal gain or delay shapes. Thus the basic equipment is readily adaptable to the adjustment of D equalizers if their gain and delay shapes are orthogonal.

#### FIELD PERFORMANCE

In the L3 system the function of the dynamic equalizers is solely to prevent excessive deterioration of the transmission characteristic from one manual line-up to the next. During the manual adjustment the dynamic networks are held at that point in their range which minimizes the probability of running out of range in either direction before the

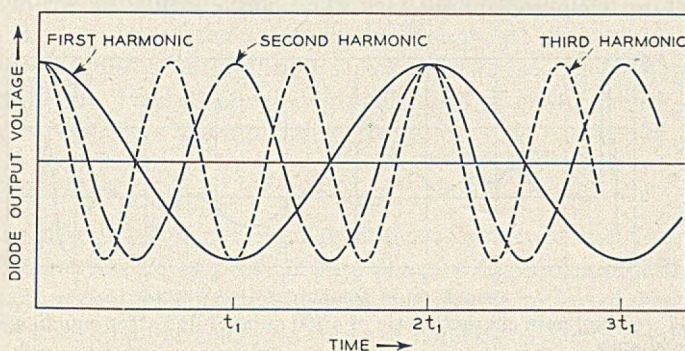

Fig. 16 — Detector output produced by scanning the first three cosine shapes.

next manual line-up. This is done to hold the dynamic ranges to a minimum. Thus the transmission errors remaining at the completion of a manual line-up are chiefly due to the fixed and manual equalizers. It should be noted however that, when the dynamic regulators are restored to operation after the manual adjustment, any residues will be seized by the dynamics and regulated.

As yet the field experience with the regulation system and the dynamic shape performance is quite limited. However, the stability of the regulation system and the action of the computer have been well established. It would appear that the major remaining regulation system problem will be the determination of the cause shapes to the accuracy required for long television systems.

Somewhat more experience has been gained with the cosine equalizers. Using a fixed equalizer design based on ten line amplifiers from initial production, a 100-mile circuit equalized using 15-cosine terms yields the residues plotted on Fig. 17. The ripple at the extreme high end of



the band is largely due to the failure of the fixed equalizer to match the very sharp cut-off of the line between 8.35 and 8.50 mc. Since telephone channels are not transmitted in this region and since television requirements are less severe at such high video frequencies (4.2 mc) this effect does not limit the transmission quality. Also note that long television circuits, over 400 miles, will have a further level of equalization, D. There is no visible impairment of ordinary television pictures due to insertion of the 200-mile L3 line in their path. With critical types of test patterns there is a slight effect. While there are problems yet to be solved before 4,000-mile transmission can be obtained, the 200-mile performance is most encouraging.

In the past the adjustment of manual equalizers has often been a difficult and time consuming task. The cosine adjusting set described

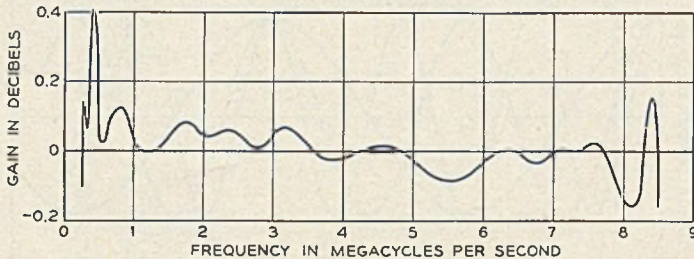

Fig. 17 — Final gain characteristic of a 100 mile L3 line after equalization with 15 cosine shapes.

previously appears to have made sizable inroads on this problem. The adjustment of the 25 controls used for television is a three minute job. The fact that the equalization operator is working toward a unique solution and therefore knows when he is done appears to be of material value.

## REGULATION

The L3 regulation system is in many respects, similar to the L1 system. However, the design of a stable regulation system for over five hundred regulators in tandem introduces unusual problems. Also the accuracy and stability requirements have led to the use of novel regulator circuits including, for example, an analog computer as an element of the system.

Six pilots are used, 308, 556, 2,064, 3,096, 7,266 and 8,320 kc. These frequencies were selected to best measure the anticipated system changes as restricted by where signal allocations would permit their insertion.



For example, the wide gap from 3,096 to 7,266 is largely due to the difficulty of inserting and removing pilots in the lower video frequencies of television signals. The problem of finding a satisfactory set of pilot levels and frequencies which will at the same time, be compatible with the desired signals is an important part of the system design problem.<sup>1</sup>

The change of four-mile cable loss with temperature is so large ( $\pm 1.2$  db) that regulation is required at each repeater. It takes three months or more for the cable loss to change 2 db but the normal line maintenance interval is of this order. A gain error of this magnitude could not be allowed to accumulate over very many repeaters before the signal to noise performance of the system would collapse. Other effects such as vacuum tube aging and repeater temperature changes can be allowed to accumulate over as many as 30 repeaters before regulation. These facts dictate the location of regulators in the system. At each repeater there is a "line" regulator controlling a square-root-of-frequency-shape regulating network. Then at equalizing points and dropping points "office" regulators correct for the remaining effects.

#### CHAIN ACTION

Pilot controlled dynamic regulators derive much of their advantage from the fact that they prevent gain changes from accumulating from repeater to repeater. This advantage is one manifestation of what might be called the "chain action" of a series of regulators. There is however a corresponding disadvantage, disturbances of the pilot cause the accumulation of unwanted gain fluctuations. In previous systems this disadvantage has been aggravated by positive envelope feedback ( $1-\mu\beta$  less than one), at some frequencies, an effect known as "gain enhancement". In the L3 system the "gain enhancement" is nearly negligible but the television requirements still require careful control of certain types of gain fluctuations.

The advantage noted above can easily be demonstrated by a simple example. Consider a chain of regulators each having 20 db envelope feedback so that pilot level changes are reduced by 10 to 1. Now consider what happens if each cable section changes loss by one db. Table I illustrates the action.

The first regulator inserts a gain change of 0.9 db in response to the 1.0 db input change. The 0.1 db error increases the input change to the second regulator to 1.1 db and it therefore inserts a 0.99 db correction.

The total resultant error of 0.11 db adds to the change at the third regulator input, etc. Simply stated: The error of the first regulator rides through the system forcing the other regulators to make an accurate



TABLE I

Regulator Number	Input Pilot Change	Inserted Correction	Output Pilot Change
	<i>db</i>	<i>db</i>	<i>db</i>
1	1	0.9	0.1
2	1.1	0.99	0.11
3	1.11	0.999	0.111
4	1.111	0.9999	0.1111

correction. Actually, of course, the above statement is oversimplified but it should be clear that the effective feedback of the regulation system is the (voltage) sum of the feedbacks of the individual regulators. Thus 100 regulators each having 20 db of feedback tend to act like a single regulator having 60 db of feedback. The rigorous treatment of these effects will be developed later.

Fig. 18 shows a block diagram of a regulator in a form intended to indicate the feedback structure. The feedback loop includes a pilot pickoff filter, amplifier and rectifier. This converts the output pilot level into a dc voltage. The "battery", which is the actual input signal for the circuit, represents the equivalent of the desired pilot output level. The signal applied to the dc amplifier is a dc signal representing the error in pilot level. This dc signal is, in effect, converted back to a pilot level by the action of the regulating network and its modulation of a pilot input level. Thus changes in input pilot level are equivalent to gain changes in the  $\mu$  circuit of the feedback structure and are resisted by feedback action just as in any other feedback "amplifier". It is also valuable to note the respective  $\mu$  and  $\beta$  roles played by the various components since the stability requirements, etc. then become clear. For

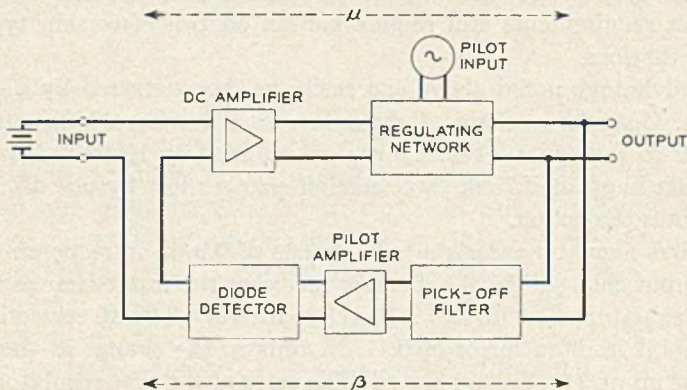

Fig. 18 — Block diagram of regulator showing the feedback structure.



example, the pilot amplifier is in the beta circuit and therefore must be a highly stable device. On the other hand, the dc amplifier is in the  $\mu$  circuit and its drifts are reduced by the loop feedback.

Having developed the feedback nature of the structure and the roles of the components, the conventional feedback art can be used for the analysis of the individual regulator. One can show that:

$$\frac{\text{Change in output pilot level}}{\text{Change in input pilot level}} = \frac{1}{1 - \mu\beta} \quad (23)$$

$$\frac{\text{System gain change to pilot frequency}}{\text{Change in input pilot level}} = \frac{\mu\beta}{1 - \mu\beta} \quad (24)$$

This result is not very surprising but it can be used to determine the performance of the following regulators in a chain. Many different cases must be considered. Sometimes the pilot levels change because of an effect distributed all along the system. In other cases the change occurs only at the input to the line. Sometimes the pilot level changes are the important effect. In other cases the importance resides in the gain change to the signals. In all cases the results may be complicated by the fact that  $\mu\beta$  is, in general, a complex number and thus phase as well as amplitude is important.

Adopting the notation:

$\Delta P_{in}$  = fractional change in input pilot at  $n$ th regulator,

$\Delta P_{on}$  = fractional change in output pilot at  $n$ th regulator,

$\Delta G_n$  = gain change to signals (near pilot frequency) of  $n$ th regulator,  
and

$\Delta G_t$  = total system gain change =  $\sum G_n$ ,

one can readily show the following:

Case I — Disturbance of pilot only at input to system:

$$\frac{\Delta P_{0n}}{\Delta P_{in}} = \left( \frac{1}{1 - \mu\beta} \right)^n \quad (25)$$

$$\frac{\Delta G_n}{\Delta P_{in}} = \mu\beta \left( \frac{1}{1 - \mu\beta} \right)^n \quad (26)$$

$$\frac{\Delta G_t}{\Delta P_{in}} = \left( \frac{1}{1 - \mu\beta} \right)^n - 1 \quad (27)$$

Case 2 — Equal gain change in each regulating section.

$\Delta P_e$  = fractional gain change of section

$$\frac{\Delta P_{0n}}{\Delta P_e} = \frac{1}{\mu\beta} \left[ \left( \frac{1}{1 - \mu\beta} \right)^n - 1 \right] \quad (28)$$



$$\frac{\Delta G_n}{\Delta P_c} = \left[ \left( \frac{1}{1 - \mu\beta} \right)^n - 1 \right] \quad (29)$$

$$\frac{\Delta G_T}{\Delta P_c} = \left[ \frac{1}{\mu\beta} \left( \frac{1}{1 - \mu\beta} \right)^n - 1 \right] - n \quad (30)$$

As an example of the application of these formulas consider the effect of television induced compression. The presence of the television signal reduces the gain of the line amplifier. The effect is small but cumulative. In the absence of regulator action it merely compresses the television signal slightly and makes a negligible change in the contrast rendering of the picture. However the regulators observe a gain change to the pilots and attempt a correction. The very rapid changes are ignored but 60 cps, for example, is partially corrected. This introduces a 60 cps gain change which will lag the picture and therefore must meet 60 cps bar pattern requirements. This problem is solved by keeping the regulator response low at 60 cps.

For  $\mu\beta$  of  $-70$  db, 90 degrees, at 60 cps a chain of 700 regulators will insert a total gain change approximately one tenth that of the total compression. If the  $\mu\beta$  were allowed to approach  $-50$ db the total gain change would equal the compression and certain types of pictures would be degraded.

The above example brings out one of the important facts: When designing regulators for long systems the  $\mu\beta$  characteristic must be carefully controlled to losses much higher than is customary in amplifier design. In a conventional feed-back-amplifier loop-cutoff the magnitude and phase of  $\mu\beta$  is no longer of much interest after it drops below  $-10$  db. In L3 regulators the loop is of vital interest to losses of the order of 70 db. This is, of course, largely due to the fact that the chain action increases the effective system feedback by nearly 60 db. Thus the over-all system is similar to conventional amplifier practice. Loop gain ( $\mu\beta$ ) and feedback ( $1-\mu\beta$ ) characteristics for the line and office regulators are shown on Figs. 19, 20, 21 and 22. Note that 1,000 line regulators in tandem give an over-all gain enhancement of only 1.2 db. This would be even less if it were not for a 100 cps roll-off in the dc amplifier to reduce noise. One hundred office regulators give 0.8 db gain enhancement even with their 20 cps roll-off.

#### THE DYNAMIC LINE REGULATOR

As indicated in Fig. 23 a crystal filter is used to pick the pilot off the line in the presence of the other signals. The filter impedance goes



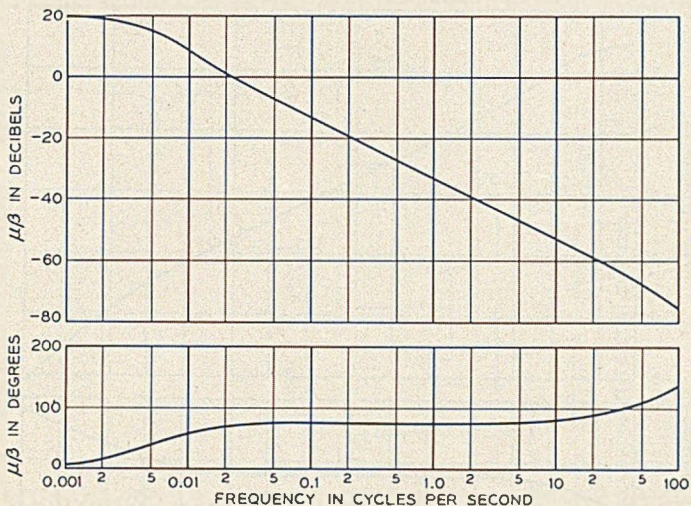

Fig. 19 — Loop gain characteristic for the line regulator.

through resonances due to the crystals and introduces a gain characteristic on the line that cannot, in practice, be equalized. Thus it is necessary to hide the filter from the line with loss. To hold the transmission distortion of signals to 0.15 db with 500 regulators (0.0003 db per regulator) requires a voltage loss of 23 db with the filter impedance changing by large factors from its nominal 25,000-ohm level. The power loss bridging on the 37.5-ohm (75 into 75) circuit is, of course, much greater.

The 7,266-ke pilot level at the line amplifier output is -16 dbm into 75 ohms. The filter and pad loss totals 24 db (voltage ratio) leaving an

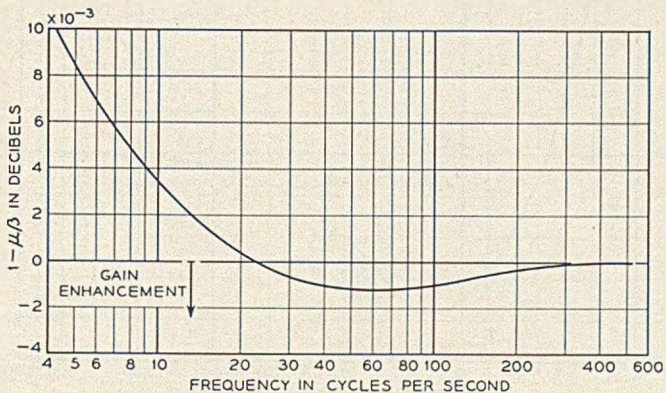

Fig. 20 — Feedback characteristic for the line regulator showing the gain enhancement effect.



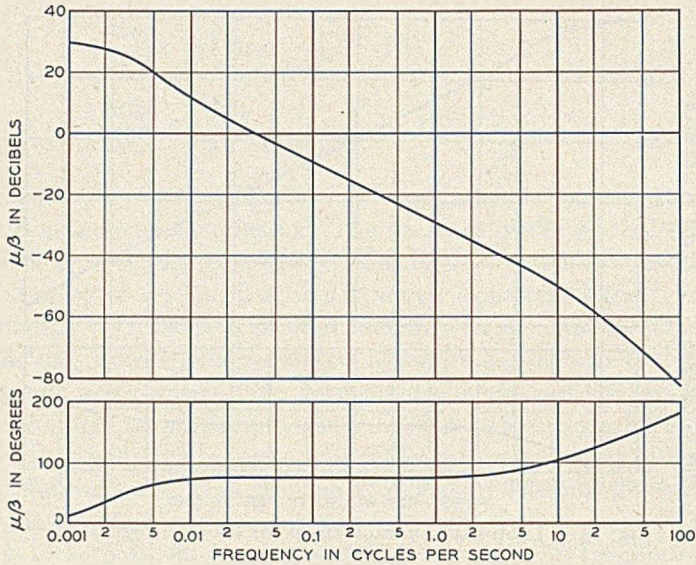

Fig. 21 — Loop gain characteristic for office regulators.

available pilot signal of about 0.002 volts in 25,000 ohms. In order to solve drift and stability problems in the dc circuits the pilot is converted to a dc voltage of 60 volts. This requires an amplifier-rectifier of 90 db voltage gain, stable with time and temperature.

As indicated on Fig. 23, the amplifier consists of three stages using

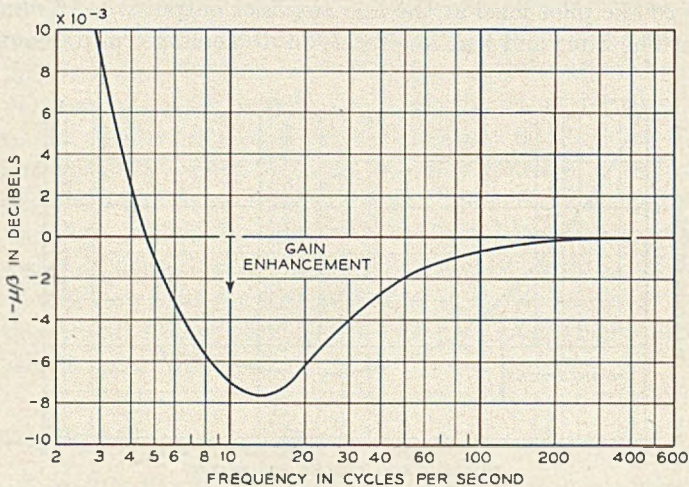

Fig. 22 — Feedback characteristic for office regulators showing the gain enhancement effect.



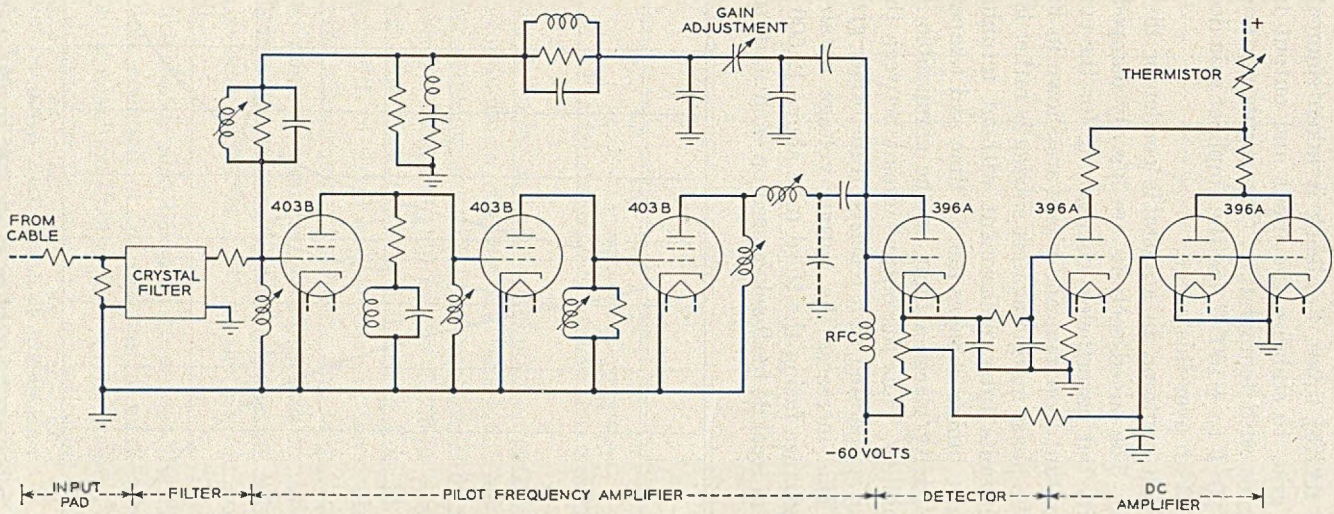

Fig. 23 — Simplified schematic of the line dynamic regulator showing the signal circuits.



403B (long life 6AK5) tubes. Feedback is taken shunt-shunt, output plate to input grid, to stabilize the input and output tuned circuits against  $Q$  changes with temperature. The regulators are designed to operate from  $-20^{\circ}\text{F}$  to  $+160^{\circ}\text{F}$  and the amplifier gain does not change by more than 0.3 db over this range.

The beta circuit contains an adjustable condenser divider for field gain adjustment. The tuned sections are heavily damped to get temperature stability but nevertheless compensate for the cutoffs of the  $\mu$  circuit. The resultant loop gain and phase are shown in Fig. 24. It will be noted that the phase margin against singing is rather large, about 60 degrees. This permits tube replacement without retuning as well as protection against tuning changes due to time and temperature.

Grid-plate capacity places a limit on the permissible interstage impedance for stability. Thus the output circuit between the third stage and the rectifier is operated as a reactive transformer giving a voltage step-up of 2. This increases the output voltage obtainable without raising the impedance facing the third tube above 12,500 ohms.

About 16 db of local dc feedback is used on each stage to stabilize the

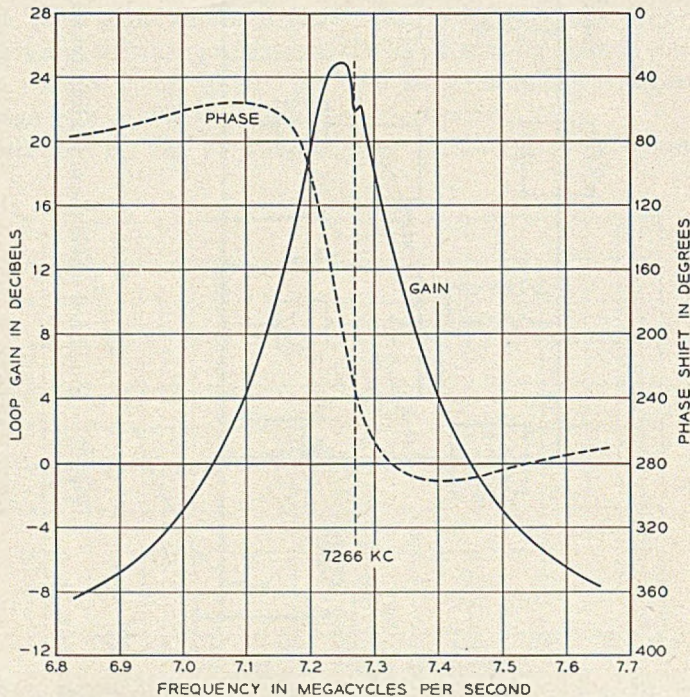

Fig. 24 — Loop gain and phase of the 7266 kc pilot amplifier.



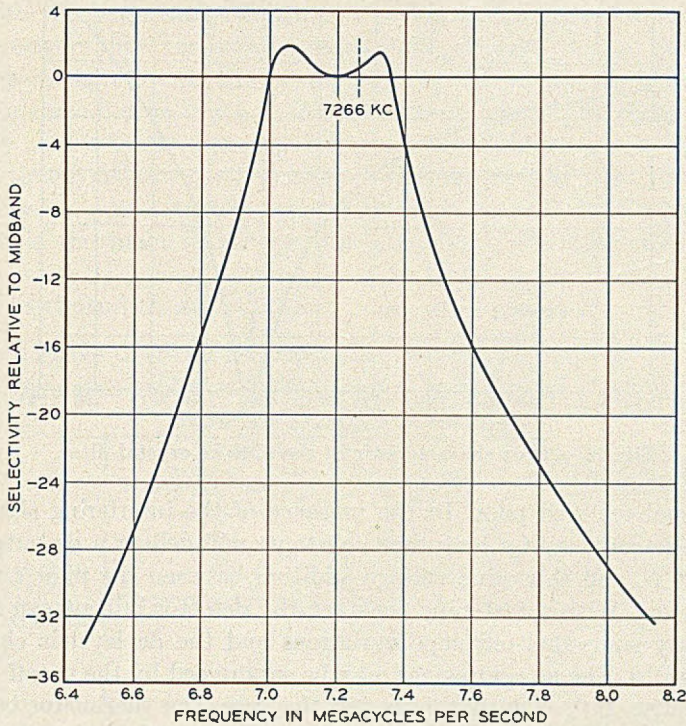

Fig. 25 — Regulator selectivity without the crystal filter.

cathode current. In so far as trans-conductance depends upon cathode current, trans-conductance changes are reduced. This is of material value in further reducing the effects of vacuum tube aging.

Fig. 25 shows the external gain of the 7,266-kc amplifier without the crystal filter. The filter response is shown in Fig. 26. The relatively wide 3 db bandwidth of  $\pm 1.5$  kc is to reduce the contribution of the filter to the gain enhancement problem. The large rejections to frequencies further removed from the pilot prevents operation of the regulator by signals other than the pilot. Also note that for very strong signals such as the television carrier at 4,139 kc the filter is aided by the amplifier selectivity.

The diode detector is also designed to reduce the effects of interference. The time constant of the detector is made short so that the output will follow envelope fluctuations up to about 40 kc. Thus the output of the detector in the presence of an interfering signal within 40 kc of the pilot becomes the power sum rather than the voltage sum of the two signals. This is readily understood from Fig. 27. Here  $E_p$  is



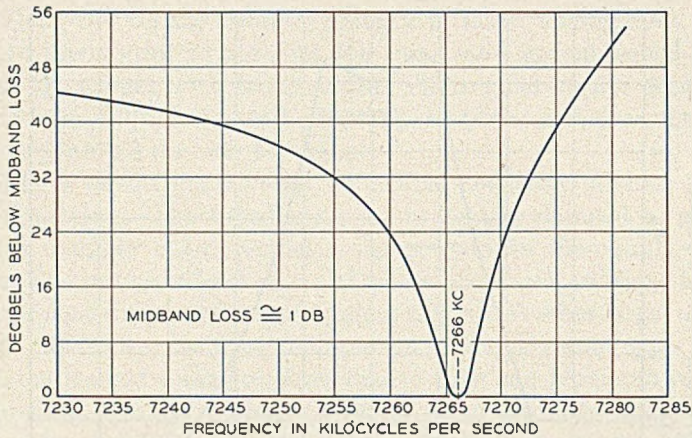

Fig. 26 — Loss characteristic of the 7206 kc crystal filter.

the normal rectified pilot. In the presence of the interfering signal  $E_i$ , a diode detector with a long time constants will deliver a dc output of  $E_p + E_i$  and thus give voltage addition between the pilot and the interference. With a fast time constant the detector output can follow the nearly sinusoidal envelope variations and the dc level is changed only slightly. The ac component may be suppressed by the cutoff of the dc amplifier, but, even if this is not the case, the thermistor being a thermal device responds to the total power rather than the peak amplitude. Thus the diode time constant is made long enough to hold over a few cycles of the pilot frequency but short enough to follow the important interference difference-frequencies.

The dc amplifier consists of three triode sections essentially in parallel

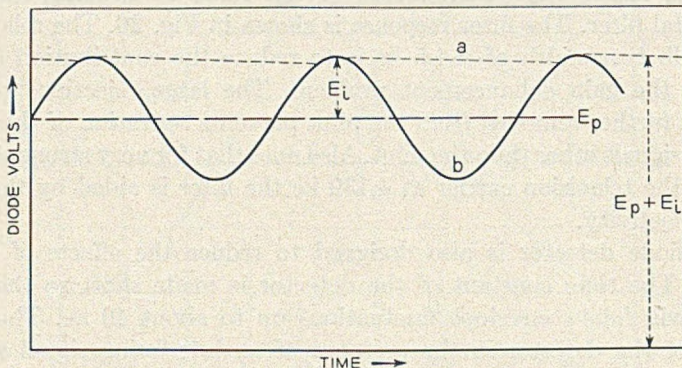

Fig. 27 — Diode detector output in presence of interference  $E_i$ .  $E_p$  is normal pilot signal. Curve a obtains with long time constant, b with short time constant.



but with the biases and feedbacks differing in order to provide an EI characteristic that corrects for sensitivity changes of the thermistor with operating current. This maintains the overall loop feedback relatively constant over the 1 to 20-ma current range. The thermistor is directly heated by the plate current of the dc amplifier in order to obtain single time-constant performance of the thermistor. The thermistor transmission, plate current changes as an input and pilot level as an output, is the main frequency characteristic of the regulator loop.

#### LINE THERMOMETER REGULATORS

It is possible to dilute the regulation system with less costly, less accurate regulators without undue loss of overall performance. This is

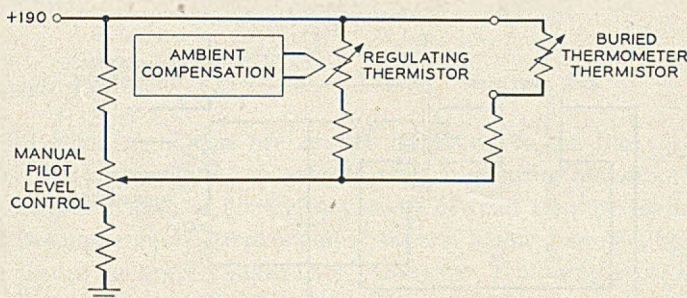

Fig. 28 — Thermometer regulator schematic.

accomplished by the use of thermometer regulators at alternate regulating points. These consist of a thermometer thermistor buried in the ground, electrically in parallel with the regulating thermistor. The circuit is quite simple as indicated by Fig. 28. Ground temperature changes vary the resistance of the thermometer thermistor thereby changing the current and resistance of the regulating thermistor. The manual control is used to effect initial alignment of the system. The regulating sensitivity is designed to slightly overcompensate for cable loss changes in order to somewhat ease the burden on the following dynamic regulator.

#### AMBIENT TEMPERATURE COMPENSATION

Both types of line regulators require the assistance of ambient temperature compensation of the regulating thermistor. Conventional compensation circuits would hold the thermistor resistance within about 20 per cent but this would produce an error of one db at a thermometer



regulator and about 0.2 db at a dynamic unit. Thus an improved compensation scheme was required which would connect only to an indirect heater, the bead itself being already controlled by dc heating from the regulators.

The compensation circuit adopted is shown on Fig. 29. A second thermistor called the compensating thermistor is mounted in the same glass envelope with the regulating thermistor. The fixed resistor  $R_1$  and the compensating thermistor together with transformer  $T$  form a bridge which is made a feedback path for tuned amplifier  $A$ . The feedback is positive when the compensating unit is cold so oscillation begins at the tuning frequency (4 kc). These oscillations heat the thermistor and tend to bring the bridge into balance. The bridge stabilizes at a

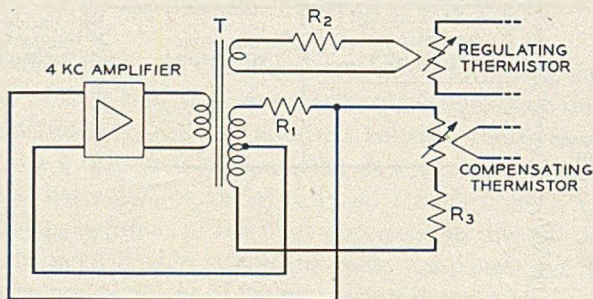

Fig. 29 — Ambient temperature compensation oscillator.

small unbalance just sufficient to yield a loop gain of unity. The level of oscillation is forced to that value which will maintain this small unbalance. Any changes in balance thereafter produce deviations of loop gain from unity and the oscillation level increases or decreases until the equilibrium is reestablished. Thus the level of oscillation changes with temperature but the resistance of the compensating thermistor is held constant.

Because the circuit supplies nearly perfect temperature compensation to the unit in the bridge a suitable fraction of the oscillator power may be fed to the heater of the regulating thermistor to achieve very close compensation of it. Resistors  $R_2$  and  $R_3$  are adjusted in manufacture to correct for slight differences between the two thermistors. Note that the compensating thermistor is provided with an unused heater to match the thermal properties of the two units.

The amplifier consists of a single 403B tube with 20 db dc feedback for current (and transconductance) stabilization. This feedback is vital



because it also introduces a slight compressive action in the amplification of the tube and thereby prevents rapid wild changes in oscillation level. Bypassed dc feedback on an amplifier causes dc second order distortion to increase the bias and thereby reduce the transconductance. This effect overcomes the tendency of the third order distortion to create expansion in this particular tube. If the thermistor response were fast compared to the reciprocal of the bandwidth of the amplifier the compression action would be unnecessary. However with an audio frequency amplifier and a 100 second thermistor the compression is essential in preventing motorboating.

The field limits on the compensation of the regulating thermistor over the range  $-20$  to  $+160$  degrees F are  $\pm 3$  per cent in resistance due to all causes including manufacture and aging. Specific units can be adjusted to yield compensation to a fraction of a per cent.

#### OFFICE REGULATORS

The L3 office regulators are similar in design to the line regulator. However the office regulators operate their regulating networks via an analog computer and, of course, a variety of pilot frequencies are employed. Because signals are dropped at offices, higher loop feedbacks are used to insure accurate equalization. However, temperature variations are smaller and conventional thermistor ambient temperature compensation is adequate. Also the smaller number of office regulators permits less isolating loss for nick effect (except for the 7,266-kc office regulator).

The lower levels of the pilots (except 7,266) are compensated by reduced isolation loss, (12 instead of 23 db), and reduced detector level (40 instead of 60 volts). Thus the gain required is not substantially increased. The pilot amplifier design is therefore different primarily in the tuning frequency and in the simplifications in the lower frequency units permitted by the higher permissible interstage impedances.

The diode detector feeds a cathode follower to obtain the dc voltage representing the deviation of the pilot from its assigned value as a low impedance source to feed the computer. The appropriate signals from the computer are fed to the dc amplifier. This amplifier differs from that used in the line regulators in that (1) a push pull input is provided, (2) higher gain is required to produce greater feedback, 30 db, and overcome computer losses, 5 db and (3) the output stage supplies somewhat higher currents, 1 to 30 ma, (except 7,266) because the regulating networks use a lower impedance thermistor.



## OTHER REGULATOR FUNCTIONS

The regulators are also used for alarm and pilot indicator functions. At line dynamic regulators the current flowing through the diode detector load resistance is also passed through a relay to obtain an alarm indication whenever the pilot level deviates from normal by more than 3 db. At offices similar arrangements operating on a 2 db error are provided both for alarm and switch initiation purposes. If any pilot deviates by 2 db the service switches to the spare line. In addition fast switch initiation is obtained from the 7,266-ke regulator by direct connection to the detector output. This arrangement avoids the time delay of the relay operation. For pilot level indication the diode load current is read on appropriate meters. This avoids the necessity of providing separate pilot level indicators and is possible because of the reliability and stability of the regulator amplifiers.

## MECHANICAL FEATURES

Figs. 30 and 31 are views of a regulator seen from the wiring side and from the top respectively. The chassis consists of two steel end plates riveted to steel angles, with a punched copper plate screwed to this

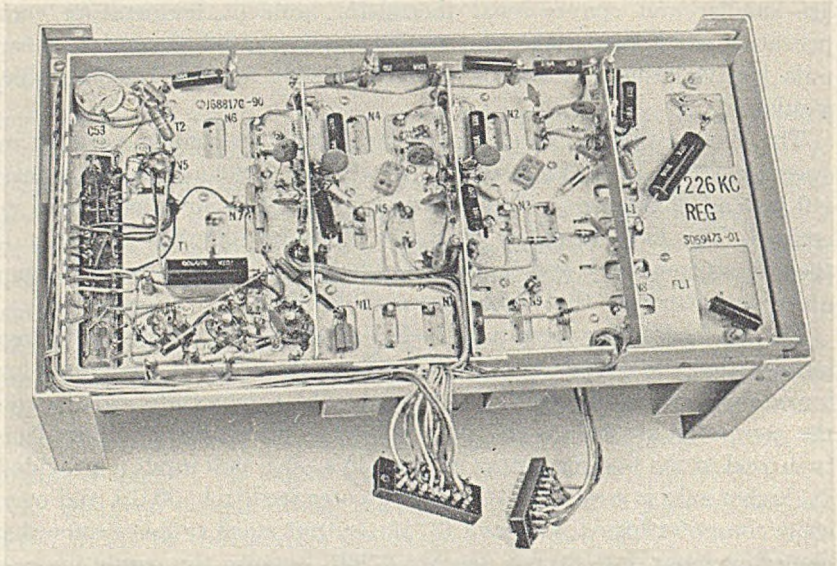

Fig. 30 — Line dynamic regulator as seen from wiring side.



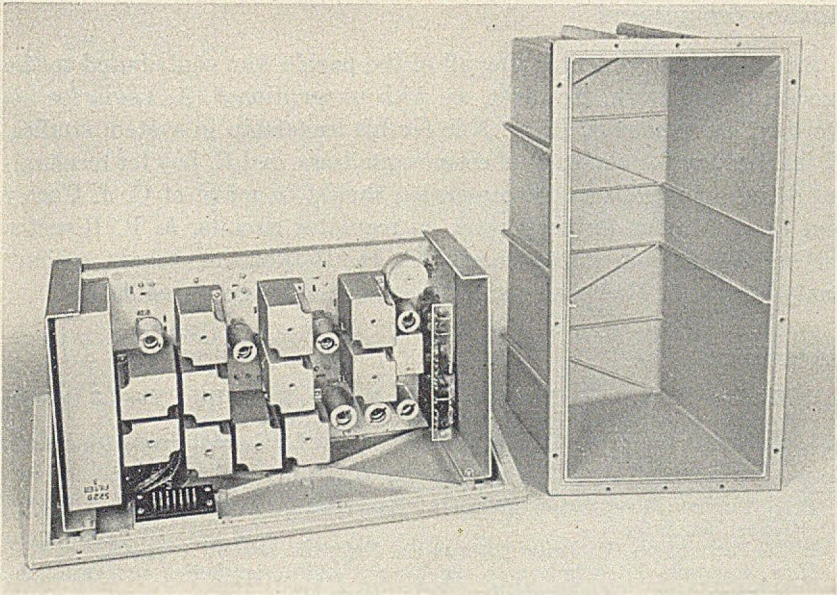

Fig. 31 — Top view of line dynamic regulator showing case.

structure. The salient feature of this type of construction is that one universal punched plate can be used for all the regulators (including the thermometer regulator), any individual regulator being fabricated by mounting the necessary component cans and vacuum tube sockets on it. Power wiring and all leads that are not critical as to length or placement can be run in the wiring trough around the edge of the chassis shown on Fig. 30. This eliminates the necessity of lacing the wires into a cable, a significant saving in production effort.

The component cases are shown on Fig. 31. They are zinc die-castings and contain network elements assembled on stypol forms which fit inside the cans. One universal case accommodates sixty-four different combinations of elements required by the various regulators. The necessary wiring of the individual cases may be completed before assembly on the regulator chassis. This feature also saves production effort.

The whole chassis is mounted inside a die-cast zinc housing, and all power and test leads are brought into the regulator through airtight connections. The two parts of the housing when assembled together are made airtight by a rubber gasket which fits into the slot around their inner edges. The general construction features and size of the regulator assembly can best be understood by inspection of the illustrations.



## ACKNOWLEDGEMENTS

Space does not permit listing all of the people who contributed to the success of this work. However, we wish to mention S. A. Levin for his work on cause shapes, R. H. Klie for his leadership in system studies, E. T. Harkless for his study of cosine equalizers, and E. Ley for mechanical design of equalizers. Also mention should be made of C. J. Custer and E. G. Morton for their work on regulator circuits, A. R. Rienstra for studies of gain enhancement, C. H. Bidwell for "chain action" analysis, and F. R. Dickinson for mechanical design of regulators.

## REFERENCES

1. C. H. Elmendorf, A. J. Grossman, R. D. Ehrbar, R. H. Klie, The L3 Coaxial System — System Design, see pp. 781 to 832 of this issue.
2. L. H. Morris, G. H. Lovell, F. R. Dickinson, The L3 Coaxial System — Amplifiers, see pp. 879 to 914 of this issue.
3. H. W. Bode, Variable Equalizer, Bell Sys. Tech J., April, 1938.
4. R. L. Lundry, Attenuation and Delay Equalizer for Coaxial Lines, A.I.E.E., Trans., 68, 1949.
5. P. H. Richardson, Variable Attenuation Network, patent 2,096,028.
6. H. S. Carslaw, Introduction to the Theory of Fourier Series and Integrals, Third Edition, 1930, MacMillan & Co., Page 148.



# The L3 Coaxial System

## Amplifiers

By L. H. MORRIS, G. H. LOVELL and F. R. DICKINSON

(Manuscript received April 17, 1953)

*The line amplifiers for the L3 coaxial system are designed to compensate for the loss of the four miles of cable which separate the repeaters; the flat amplifiers are used to compensate for equalizer loss and as transmitting amplifiers. The two types are basically similar, consisting of two feedback amplifiers in tandem separated by an inter-amplifier network; in the line amplifier this network is variable and is automatically adjusted to compensate for variations in cable temperature and for small deviations from the nominal four-mile spacing.*

*Coupling networks employing high-precision transformers are used to connect the amplifiers to the coaxial cable through the required power separation filters. The low impedance windings of the transformers are center-tapped and a balancing network provided in order to match the cable impedance over the transmitted frequency band. The amplifiers are equipped with plug-in tubes of high figure of merit which were developed for this application. A double-triode output stage is used to obtain improved system signal-to-noise performance. Provision is made for preventive maintenance of vacuum tubes and for a controlled adjustment of gain on an in-service basis.*

*All important components of the amplifier are subject to quality control procedures to assure that the average gain of groups of amplifiers will be held within narrow limits and that individual amplifiers will form a normal distribution around the average. This approach is essential in order to meet system equalization and signal-to-noise objectives. Careful mechanical design and rigid control of the mechanical aspects of manufacture are necessary to minimize gain variations which might be caused by variations of parasitic circuit elements and unwanted feedback effects. Special measures were required to keep the temperature rise within the sealed die-cast housing within tolerable values.*



## INTRODUCTION

In a transmission system such as the L3 coaxial, the degree to which system objectives are achieved is largely dependent on the quality of the amplifiers which compensate for the cable loss. To a considerable extent the same statement applies to the similar flat-gain amplifiers used to make up for the loss of the equalizers at various points along the route. The development of an amplifier which would meet the exacting requirements of the L3 system was in turn dependent on new developments in the fields of vacuum tube design and circuitry, network design techniques, element and network fabrication, and statistical quality control. To these new tools were added the lessons learned in years of manufacture and operation of the preceding L1 system.

The importance of some of these factors can best be illustrated by examining the implications of the amplifier requirements which follow from the material in the companion papers on system design<sup>1</sup> and equalization.<sup>2</sup> Obviously the figure of merit, modulation coefficients and life of the vacuum tubes will be determining factors in setting the amount of feedback that can be obtained and the signal-to-noise ratio of the system. It is not so immediately apparent that system requirements could not be met with the present 4-mile repeater spacing if it were not for the use of quality control at every stage of manufacture from elements, and even the raw materials entering into components, to complete amplifiers. As the companion papers show, however, the equalization plan of the system is predicted on a degree of reproducibility of amplifier gain and delay characteristics obtainable only by quality control applied at every stage of the manufacturing process.

The present equalization plan is based on the assumptions that the gain of the average line amplifier will match the loss of the preceding line section to within 0.15 db, and that the average amplifier gain will not vary from one batch of new amplifiers to another by more than about 0.06 db. Under these assumptions a system equalization plan can be worked out which results in reasonable spacing between equalizers, a tolerable signal-to-noise penalty due to misalignment and equalizer loss, and a practicable procedure for adjusting long systems. Any gross departure from the basic assumptions as to reproducibility of amplifiers would seriously compromise these objectives, which even now are achieved only by using equalization which requires a flat gain amplifier for every four or five line amplifiers. Now it turns out that with the most precise elements that can be made, the gains of individual amplifiers will vary by about  $\pm 0.6$  db. We need, therefore, a tool which will permit us to control the gain of the average amplifier to an order of magnitude



greater precision than we can economically control the individual. This is exactly the effect which modern methods of statistical quality control aim at achieving, and since the entire amplifier is merely the sum of its parts, quality control must start at the roots of the manufacturing process. In order to apply quality control intelligently, and to be sure that all important causes of gain variation are understood, it has been necessary to carry out, side by side with empirical laboratory work, a program of computing the insertion gain of the amplifier, starting with fundamental element values. These computations have also proven of value in obtaining satisfactory stability margins in the design of the low and high frequency cut-offs of the feedback loops, and in obtaining preliminary information on amplifier gain deviations for use in equalization planning.

The severe gain and delay reproducibility objectives also have their effect on the mechanical design of the amplifier. At first sight the unit appears to be a lumped constant structure rather than one in which distributed effects would be of paramount importance. Usually the circuit designer in such a case is interested in the mechanical design only for reasons of neatness and economy, but when we look deeper we find that in the amplifier structure as a whole as well as in the case of certain components, the effects of distributed capacity and inductance could easily defeat our objectives if the mechanical design were not such as to assure precise control of element placement and wiring lengths.

For these reasons, an order of mechanical accuracy is specified beyond that which can be justified by the accuracy of transmission measurements on individual amplifiers. This striving for mechanical accuracy is carried all the way through, from element piece parts through subassemblies to the assembly on the final amplifier framework. The logical expectation is that by reproducing the amplifiers as exactly as possible we will control not only the known elements but also the many parasitic effects, and thereby minimize the appearance of shifts in amplifier gain and delay which would be substantial in the system even though difficult to detect in the measurement of individual amplifiers.

Another design feature of the amplifier based on the system equalization point of view is the omission of all adjustable elements, or trimmers, to control the transmission. By eliminating gain adjustments, the possibility of adjusting one element to compensate for the short-comings of another, and the possibility of systematic errors of setting due to faulty or inaccurate adjustment techniques, are both eliminated. Either of these possibilities would tend to convert relatively large random effects into smaller but systematic effects, a conversion which would penalize



the system equalization. Obviously, however, the elimination of gain adjusting elements puts a higher premium than ever on the requirement that all elements, including tube capacities, show only small random variations about tightly controlled nominal values.

In addition to the gain requirements discussed above, the following line amplifier objectives are to be met:

1. The gain of the amplifier must be continuously variable, under the control of a regulator circuit, to compensate for differences in lengths of cable sections and for variations of cable loss caused by temperature changes. The shape of the gain change should match the square root of frequency shape of the line loss change over the transmitted band to within a few hundredths of a db. This accuracy of shape, which of course is based on equalization considerations, should hold over the entire regulation range, which is about  $\pm 6$  db at the top transmitted frequency.

2. The input and output impedances of the amplifier should match the cable impedance in order to minimize the effects, on television transmission, of echoes caused by line irregularities such as splices. Tolerable values of reflection coefficient at amplifier input and output are about 5 per cent at the television carrier and 10 to 15 per cent at upper band edge.

3. Feedback consistent with system modulation requirements, shaped across the transmitted band to minimize low frequency intermodulation products and to give a smooth, easily equalized shape of gain change as tubes age, must be obtained while maintaining adequate margins against singing.

4. Other requirements include design and selection of elements to assure as small a change of gain versus ambient temperature as possible, mechanical design provisions for keeping the temperature rise within the unit to a minimum both in order to keep the temperature-gain effect small and to obtain long element life, a sealed housing to avoid damage by humidity in exposed locations, and provision of facilities for testing tubes in service.

## CONFIGURATION

The circuit configuration of the line amplifier is shown in Fig. 1. It consists of two independent feedback amplifiers with a regulating network between them acting like a two-terminal interstage. Each of the amplifiers is essentially a two-stage circuit — the input amplifier literally so and the output amplifier essentially so since the double-triode output circuit acts like a single stage. Each amplifier is connected to the coaxial through a coupling network which consists of a transformer



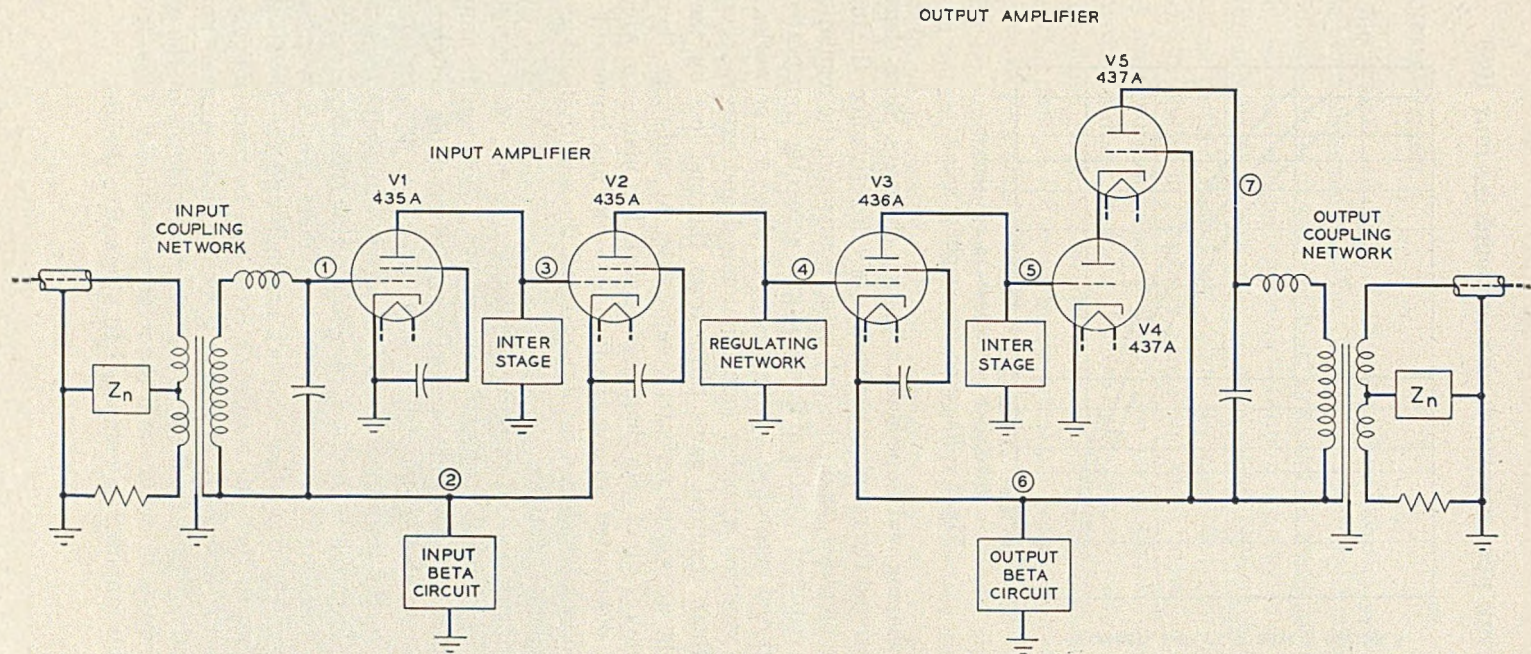

Fig. 1 — L3 line amplifier configuration.



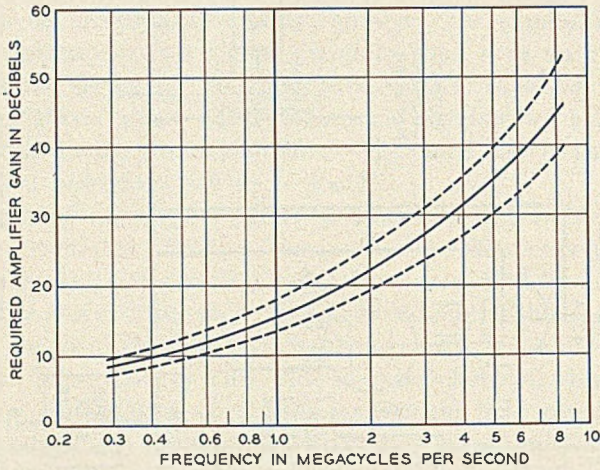

Fig. 2 — Required line amplifier gain.

plus gain shaping and impedance adjusting elements. Since there is no feedback around the coupling networks, they directly affect the insertion gain of the amplifier, as do the two beta circuits and the regulating network. The required shaping of insertion gain across the transmitted band is obtained and controlled by the design of these five networks. Fig. 2 shows the required amplifier gain for nominal and extreme thermistor settings; these required gains differ from the line loss by the small losses of the associated repeater components. At mid-range thermistor setting about 37 db of gain shaping is needed. The manner in which this shaping is distributed among the five networks has important effects on the feedback which can be obtained and the sensitivity of amplifier gain to element variations.

This configuration offers several advantages, one of the most important of which is that the regulating network is between the amplifiers. In most other configurations, the only gain-determining network available for the regulating function is the beta circuit. When the feedback is not infinite, this introduces errors for which it is difficult to compensate, and limits the available feedback by complicating the design. In this configuration, the impedances which the amplifiers effectively present as shunts across the regulating network are high and can be allowed for in the design so that the regulation error can be made much smaller than the error associated with beta circuit regulation in an amplifier having relatively little feedback. Other major advantages are the superior signal-to-noise performance and the relative simplicity of the feedback loops of this amplifier as compared to alternative designs.



## MECHANICAL DESIGN

The mechanical assembly of the amplifier, like the configuration, is divided into three main sections. The input and output amplifiers are mounted on separate chassis which are designed for ready removal from the main base casting. The regulating network is mounted in an enclosed, shielded compartment which also serves to shield the component amplifiers from each other. Figs. 3 and 4 show the assembled amplifier.

Because of the wide frequency range and close control of parasitic capacity and lead inductance required, the L3 amplifier was designed as an integrated whole, and all networks were designed with, and as part of, the amplifier. In each case circuit elements were placed in space in the best possible position for optimum electrical performance, and supporting structures were then designed to maintain the desired space relationships. These supporting structures are made as separate units which mount on the amplifier chassis, so that the networks can be individually tested before final assembly into the amplifiers, and can be removed for repair or replacement if necessary.

Heretofore, this method of design has been impracticable because it results in very complicated supporting structures. It was feasible in this case because of the availability of a new type of material, which removes many of the mechanical design constraints. This is a cold casting resin, and parts are produced in a cheap phenolic mold. Since the process is practically equivalent to the sand-casting of metals, complex parts can be economically manufactured even in the relatively small quantities required for L3 production. Where necessary to assure accurate

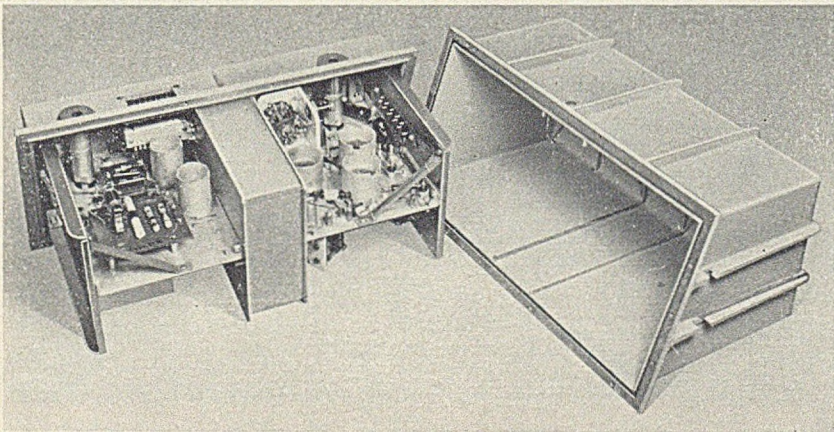

Fig. 3 — Line amplifier and housing.



location or orientation of parts, the cast resin frameworks are milled or spot-faced. The structure used in the input interstage, shown in Fig. 5, is an example. Circuit elements are wired to pins driven into the casting or, in some cases, to wires imbedded in the material. All wiring can thus be made direct with a minimum of bending and no doubling back, resulting in a reproducible and uniform product.

The entire amplifier is housed in a sealed die cast container to protect the components from humidity damage. Dessicant is enclosed in each amplifier. It would have been desirable to make this housing of aluminum, but the high melting point of this metal makes it impractical for such a large casting to meet the air-tightness requirement. A zinc-base die casting alloy was therefore used. Sealing is accomplished by rubber gaskets at all openings for connections and at the joint between the two parts of the housing. The removable part of the casting which serves as a cover is made as large a part of the total housing as possible, in order to provide maximum accessibility for maintenance of the units mounted on the base. The entire housed unit is arranged to mount on a relay rack mounted panel by means of slides which are self-locking. Signal and power connections are made by means of flexible cords which

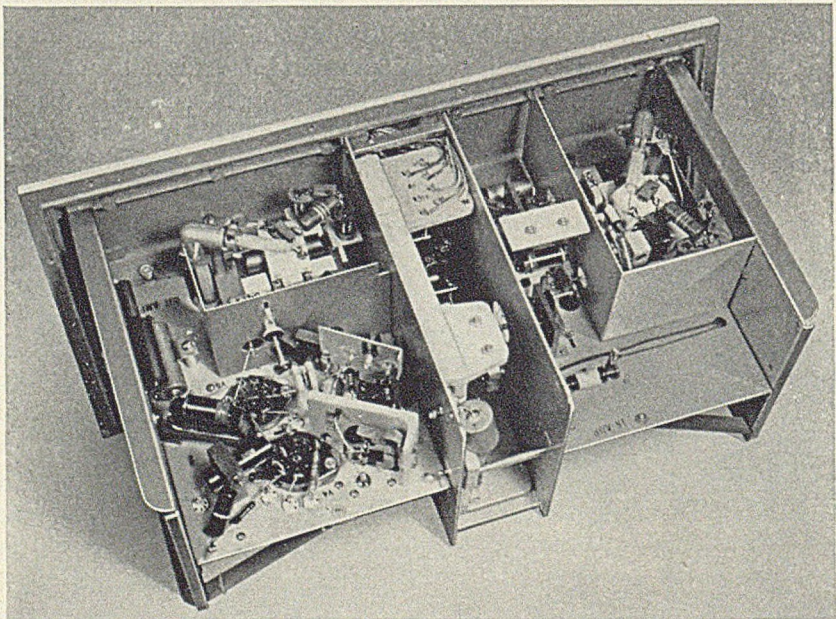

Fig. 4 — Line amplifier, wiring side.



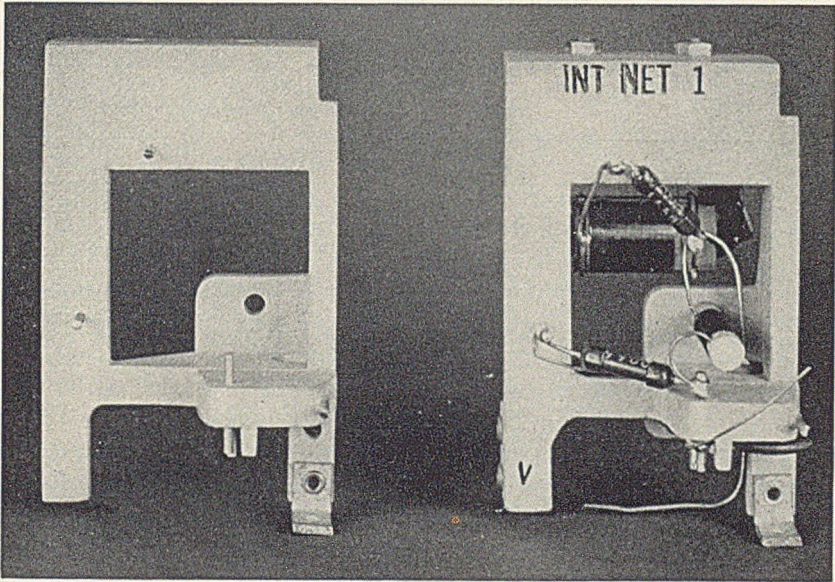

Fig. 5 — Input interstage, illustrating use of case resin frameworks.

are available on the panel to plug into the unit after it is in place on the slides.

#### VACUUM TUBES

The tubes have been fully described in an earlier paper;<sup>3</sup> their characteristics are summarized in Table I. They are plugged into conventional sockets, and single rather than parallel tubes are used in each stage. These are departures from the practice of the L1 coaxial system, in which two tubes in parallel were soldered in each stage. The use of sockets increases the parasitic capacities and reduces the obtainable feedback by one or two db, but it was felt that the resulting maintenance economy was worth this sacrifice. With single tubes, the failure of one tube results in a line failure and a switch to the protection line. At first sight, it would appear that using parallel tubes in each stage should greatly decrease the probability of line failure. A study of L1 experience, however, showed that most tube failures could either be forestalled by preventive maintenance, or else were of such a nature (for example, shorts within the tube) that the parallel tube would not afford protection against line failure. The reliability advantage of parallel tubes, then, turns out to be small; their use, on the other hand, increases the wiring



TABLE I — TUBE CHARACTERISTICS, DESIGN CENTER VALUES,  
NEW TUBES

	435A Tetraode	436A Tetrode	437A Triode
Heater voltage.....	6.3	6.3	6.3 volts
Heater current.....	0.3	0.45	0.45 amperes
Plate-cathode voltage.....	180	180	150 volts
Screen-cathode voltage.....	150	150	— volts
Grid-ground voltage.....	9.0	9.0	9.0 volts
Cathode bias resistor.....	630	315	262 ohms
Plate current.....	13.1	23.4	40.2 milliamp
Screen current.....	3.2	8.6	— milliamp
Transconductance.....	16.5	32.0	47.0ma/volt
Plate resistance.....	—	—	970 ohms
Grid-cathode bias.....	1.3	1.1	1.5 volts
<i>Capacitances (Approximate hot values in mmf)</i>			
Grid to plate.....	0.02	0.04	3.6
Grid to cathode and screen.....	9.2	18.2	16.4
Grid to heater.....	0.6	0.8	0.1
Plate to cathode and screen.....	1.0	1.5	0.7
Heater to cathode and screen.....	5.4	7.2	5.4
Heater to plate.....	1.7	1.9	0.2
<i>Modulation*</i>			
Second order (2F).....	36	—	36 db
Third order (3F).....	66	—	67 db
Third order "effective" (3F).....	60	—	60.5 db
Equivalent noise resistance, ohms.....	460	180	—

\* Ratio of product to fundamental at output for a 0.1 volt rms signal from grid to cathode.

complexity greatly when sockets are used. The small gain in reliability would not compensate for the degradation in performance caused by the complication of wiring and the resulting capacity penalties.

The applied voltages and current drains are shown in Table II.

## HEAT DISSIPATION

In common with many modern designs with high gain vacuum tubes, the problem of heat dissipation was acute in the L3 amplifier. The amplifier is enclosed in a sealed housing of sufficient size to dissipate readily the heat generated. However, with the usual types of chassis and tube shield construction, vacuum tube envelope temperatures were so high that long tube life could not be assured. Consequently a new type of tube shield was developed. This shield is of heavy copper tubing equipped



TABLE II — POWER REQUIREMENTS OF AMPLIFIER UNIT

6.3 volts (grounded).....	1.5 amperes
6.3 volts (190v off ground).....	0.45 amperes
+100 volts regulated.....	0.5 milliamps
+190 volts.....	68 milliamps
+315 volts.....	41 milliamps

with internal helical springs mounted in such a manner that each turn of the spring makes contact with both the glass tube envelope and with the copper tube as shown in Fig. 6. Thus each turn of the spring provides two metallic heat conducting paths to carry away the heat from the tube envelope. A total of 480 conducting paths are provided for each of the large tubes used in the output amplifier by the use of these springs. Good contact is made between the copper tubes and the chassis, so that heat generated within the vacuum tube is efficiently conducted through metallic paths to the copper chassis of the amplifier. In order not to raise the temperature of the chassis and consequently the temperature of the circuit components, large ribs are provided in the housing, with which the chassis make intimate contact. A continuous metallic con-

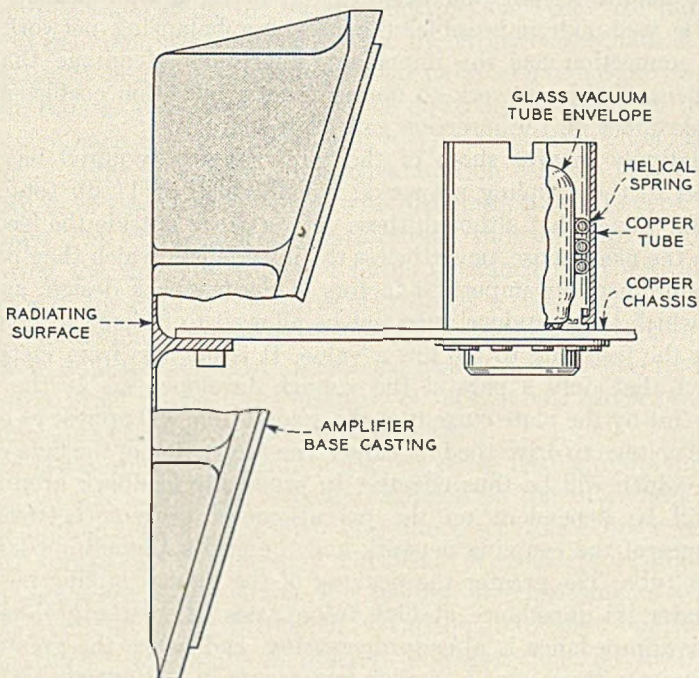

Fig. 6 — Heat conducting tube shield.



ducting path is thus provided from vacuum tube envelope to amplifier housing. This design resulted in a temperature drop in the output amplifier tubes of about  $70^{\circ}\text{C}$  without any temperature rise in the chassis or circuit elements over that produced when ordinary types of shields were used. The smaller vacuum tubes in the input amplifier do not ordinarily run as hot as those in the output amplifier and a temperature drop of only about  $55^{\circ}\text{C}$  was attained by these methods.

### COUPLING NETWORKS

The input and output coupling networks are essentially identical. The low side of each transformer is a balanced center-tapped winding which together with the balancing network acts as a hybrid, to produce a good 75-ohm impedance facing the cable. The use of this type of connection gives a signal-to-noise advantage over the use of a brute-force high-side terminating network. The advantage is theoretically 3 db in the case of the output coupling network and would approach the same figure in the case of the input network if tube noise were dominant over the resistance noise of the cable.<sup>4</sup> Aside from the fact that the design of a high-side shunt termination network for an off-ground peaked transformer is well-nigh impossible, the use of a balancing network in a hybrid connection has the important additional advantage that the adjustment of this network to obtain a good reflection coefficient has negligible effect on the insertion gain of the circuit.

A relatively modest share of the total shaping required has been allocated to the coupling networks: 5.5 db each, or 11 db total. One reason for this is that although these networks are outside the feedback loops in the usual sense, nevertheless the impedances which they present to the amplifiers are important factors in the feedback design, and the effects which they produce must not be allowed to become so severe as to limit the feedback to too low a value. It is obvious from inspection of Fig. 1 that only a part of the voltage developed across the input beta circuit by the plate current of the second tube will appear as a grid-cathode voltage to drive the first stage. The proportion of the beta circuit voltage which will be thus effective in producing feedback around the loop will be dependent on the potentiometer division between the impedance of the coupling network and the grid-cathode impedance of the first tube. The greater the peaking of the input coupling network, the greater its impedance at high frequencies where the grid-cathode capacitive impedance is already decreasing, and hence the greater the potentiometer term loss. A similar loss occurs in the output amplifier. The plate current of the output stage divides between the output



coupling network and the parasitic admittances to ground. The portion of the plate current which returns directly to cathode (ground) through the latter path, without passing through the beta circuit, is not effective in producing loop feedback.

A second and even more important limitation is that the sensitivity of the insertion gain to variations in the coupling network elements is increased as the slope is increased. The same considerations lead us to keep not only the slope but also the gain level or efficiency of these networks relatively low. The maximum possible coupling network gain which can be obtained over the entire frequency spectrum is limited by the capacity across the circuit, as shown by Bode's Resistance Integral Theorem. This capacity cannot be reduced without incurring a more severe potentiometer term penalty and thus limiting feedback, so that the total gain area cannot be profitably increased. The in-band gain can be made greater or less as we concentrate more or less of the total gain area in the transmitted band, but it is found that attempting to get high values of in-band gain area leads to networks which are increasingly sensitive to element deviations. A resistance area efficiency of about 50 per cent turns out to be the most acceptable compromise.

In spite of these steps, the coupling networks are the most important source of manufacturing deviations, but by improved mechanical design and the use of quality control these effects have been reduced by an order of magnitude as compared to previous designs. For example, the end-capacity of each coupling network is a quartz-disc condenser, and the peaking or splitting coils are tension-wound on ceramic forms to give inductances of 1 per cent tolerance with distribution requirements within this range. The windings of the transformers, shown in Fig. 7, are made by plating the turns on threaded forms machined from optical grade quartz or Vycor glass to tolerances of tenths of a thousandth of an inch. Leakage inductance and parasitic capacity deviations are thus held to a minimum. Split ferrite cores, which must also be held to close tolerances, make it possible to use these methods of fabrication, which previously available tape cores would not have permitted.

Since the amplifier configuration gives series feedback on the tubes adjacent to the cable, and cathode feedback on the tubes adjacent to the regulating network, the high impedance winding of each coupling network is necessarily off-ground. This leads to considerable difficulty in specifying the equivalent circuit. For an on-ground coupling network, the equivalent circuit of Fig. 8(b) would be adequate for gain and feedback computations — essentially a reactive equalizer plus an ideal transformer. Even then the capacities and inductances associated with the



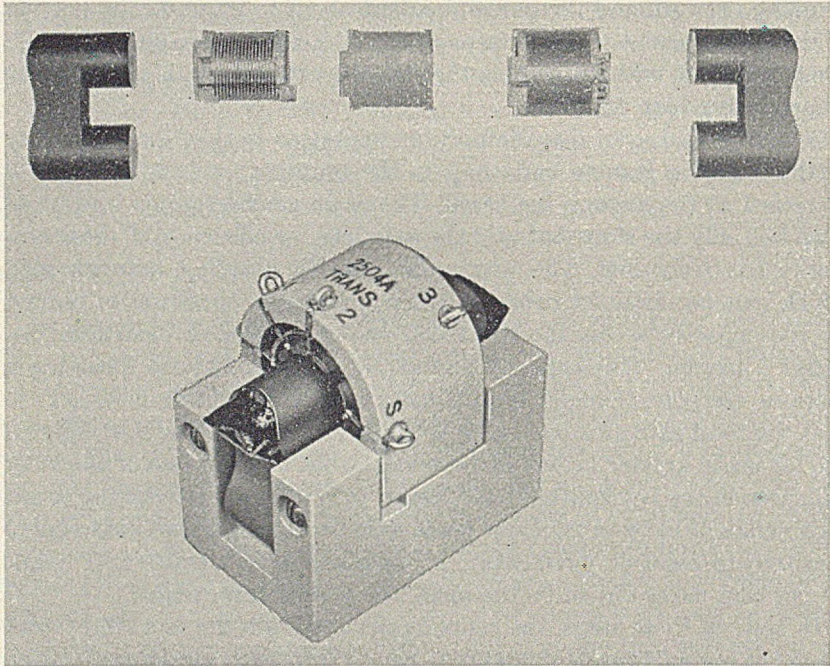
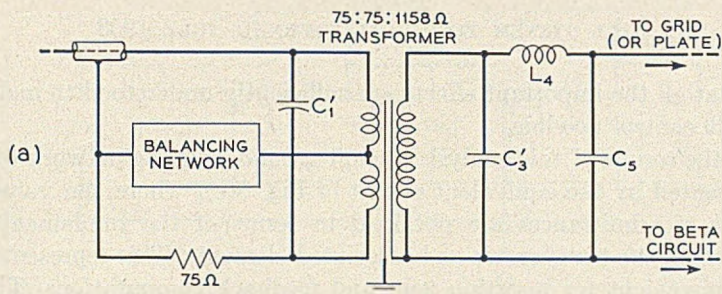

Fig. 7 — Precision transformer, windings, core, assembled unit.

transformer itself would have to be given as functions of frequency because of the distributed nature of the device. When, however, the high impedance winding is raised above ground potential by the voltage developed across the beta circuit, which is nearly the same magnitude as the voltage across the coupling network, the effects of distributed parasitic capacities to ground, and the lumped capacity from the junction of transformer and peaking coil, become of prime importance. The coupling network, therefore, cannot be adequately represented by merely lifting the circuit of Fig. 8(b) off-ground.

In order correctly to understand and compute the amplifier gain, it was necessary to develop a complex mathematical analysis of the distributed structure of the transformer, in conjunction with an extended program of precise measurements of the transformer constants. Even then, one must be content with an accuracy of a few tenths of a db and a few degrees of phase, as compared with the order of magnitude better accuracy which can be obtained for a two-terminal lumped-constant network. The agreement between measurement and computation of amplifier gain and reflection coefficient is sufficiently good, however, to





- $C'_1$  LOW SIDE PADDING CAPACITANCE  
 $C'_3$  HIGH SIDE PADDING CAPACITANCE  
 $L_4$  PEAKING COIL  
 $C_5$  PEAKING CAPACITANCE

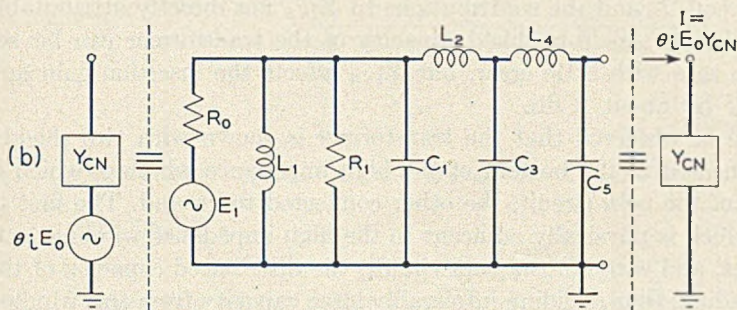

- $E_1$  EQUIVALENT GENERATOR,  $\sqrt{\frac{1158}{150}}$  X CABLE OPEN CIRCUIT VOLTAGE,  $E_0$ .  
 $R_0$  1158Ω.  
 $L_1, R_1$  MUTUAL INDUCTANCE, DISSIPATION OF TRANSFORMER.  
 $C_1$  LOW SIDE CAPACITY X  $\sqrt{\frac{150}{1158}}$   
 $L_2$  LEAKAGE, REFERRED TO HIGH SIDE OF TRANSFORMER.  
 $C_3$  HIGH SIDE CAPACITY OF TRANSFORMER (INCLUDING PADDING CONDENSER).  
 $L_4, C_5$  PEAKING ELEMENTS.

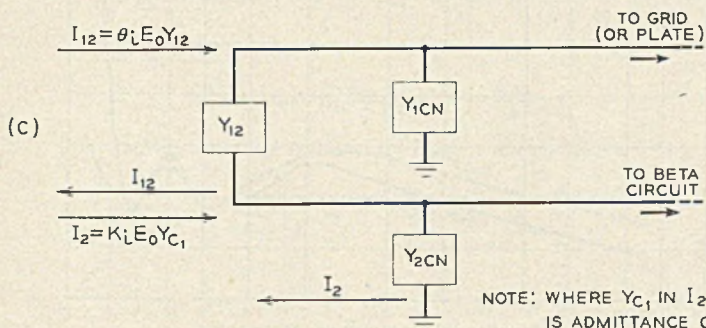

NOTE: WHERE  $Y_{c1}$  IN  $I_2$  FORMULA IS ADMITTANCE OF CABLE

Fig. 8 — Coupling Network Circuits. (a) Physical elements. (b) On-ground equivalent circuit, adequate for gain and feedback computations in an amplifier configuration employing on-ground coupling networks. (c) Off-ground equivalent circuit.



assure that all the important effects are sufficiently understood to make intelligent control possible.

Using the results of this analysis, the off-ground coupling network can be represented by the equivalent circuit of Fig. 8(c), where the values of the pi of admittances are obtained in terms of the fundamental parameters of the transformer and associated elements. This representation is convenient for insertion gain and feedback computations. The most important difference between the equivalent circuits of Figs. 8(b) and 8(c), from a practical standpoint, is the presence in the latter of the admittance  $Y_{1CN}$  which is a manifestation of the capacity to ground from the high impedance winding and the junction of transformer and peaking coil.  $I_2$  and the contributions to  $Y_{2CN}$  not directly attributable to the obvious shield-to-shield capacity of the transformer can be set equal to zero with little error, but  $Y_{1CN}$  affects the insertion gain and feedback by about 2 db.

It will be observed that the transformer is shown with two shields, one connected to the bottom of the high impedance winding, which is the top of the beta circuit, the other connected to ground. The first of these, which is physically adjacent to the high impedance winding, acts to collect, and carry to the beta circuit, the distributed capacity of the high winding, thus avoiding intolerably large capacity from this winding to ground. The second shield prevents capacitive coupling of the large beta circuit signal voltage to the low impedance winding, which would lead to a very poor reflection coefficient performance. Typical curves of reflection coefficient are shown in Fig. 9. Since the amplifier is an active device, the reflection coefficient is to some extent a function of the vacuum tube transconductances, and tends to be degraded as tubes age.

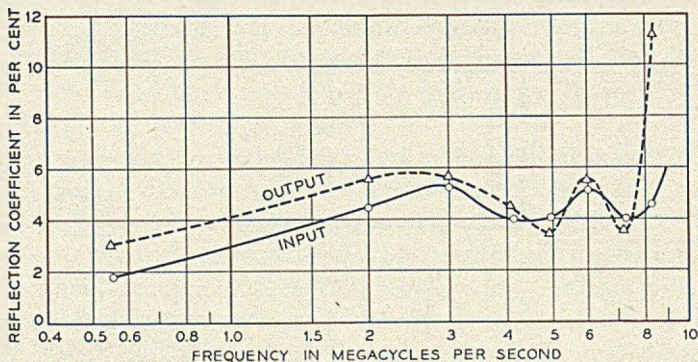
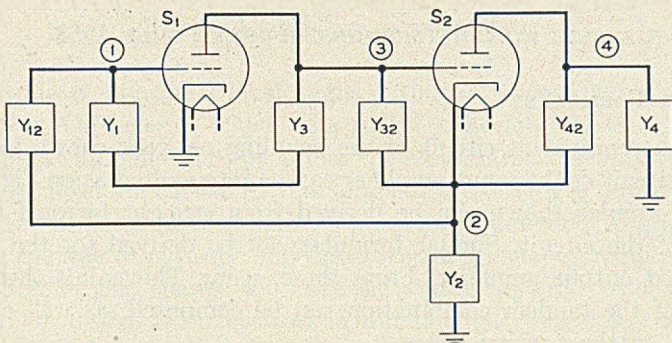

Fig. 9 — Reflection Coefficients.





NODAL DETERMINANT OF CIRCUIT:

$$\Delta = \begin{vmatrix} E_1 & E_2 & E_3 & E_4 \\ Y_{11} & -Y_{12} & 0 & 0 \\ -Y_{12} & Y_{22} + S_2 & -Y_{32} - S_2 & -Y_{42} \\ S_1 & -Y_{32} & Y_{33} & 0 \\ 0 & -Y_{42} - S_2 & S_2 & Y_4 + Y_{42} \end{vmatrix} \begin{matrix} I_1 \\ I_2 \\ I_3 \\ I_4 \end{matrix}$$

WHERE  $Y_{11} = Y_1 + Y_{12}$ ;  $Y_{22} = Y_2 + Y_{12} + Y_{32} + Y_{42}$ ;  $Y_{33} = Y_3 + Y_{32}$

FEEDBACKS

$$\text{RETURN RATIO ON FIRST TUBE: } T_1 = \frac{P_{12} \frac{S_1 S_2}{Y_{33} Y_2} P_4 + P_{12} \frac{S_1}{Y_2} P_{32}}{1 + P_3 \frac{S_2}{Y_2} P_4} = \frac{B + D}{1 + E}$$

$$\text{ON SECOND TUBE: } T_2 = \frac{P_{12} \frac{S_1 S_2}{Y_{33} Y_2} P_4 + P_3 \frac{S_2}{Y_2} P_4}{1 + P_{12} \frac{S_1}{Y_2} P_{32}} = \frac{B + E}{1 + D}$$

WHERE  $P_{12} = \frac{Y_{12}}{Y_{11}}$ ;  $P_4 = \frac{Y_4}{Y_4 + Y_{42}}$ ;  $P_3 = \frac{Y_3}{Y_{33}}$ ;  $P_{32} = \frac{Y_{32}}{Y_{33}}$

$Y_2' = Y_2 + \sigma_1 + \sigma_3 + \sigma_4$ ;  $\sigma_1 = \frac{Y_{12} Y_1}{Y_{11}}$ ;  $\sigma_3 = \frac{Y_3 Y_{32}}{Y_{33}}$ ;  $\sigma_4 = \frac{Y_4 Y_{42}}{Y_4 + Y_{42}}$

TRANSMISSION

$$E_4 = I_{12} \frac{\Delta_{14} - \Delta_{24}}{\Delta} + I_2 \frac{\Delta_{24}}{\Delta}$$

USING FOR  $I_{12}$  AND  $I_2$  THE VALUES GIVEN ON FIGURE 8 (C)

$$E_4 = E_{cc} \left[ \mu_l \frac{Y_2}{Y_4} \frac{B - D \frac{\sigma_4}{Y_2} - E \frac{\sigma_1}{Y_2} - \frac{\sigma_1}{Y_2} \frac{\sigma_4}{Y_2'}}{1 + B + D + E} + K_l Y_{c1} \frac{1}{Y_4} \frac{B + E + \frac{\sigma_4}{Y_2}}{1 + B + D + E} \right]$$

Fig. 10 (a) — Input amplifier formulas.



## AMPLIFIER FORMULAS

Using the equivalent circuit of the coupling network shown in Fig. 8(c), the circuit of the input amplifier can be represented as on Fig. 10a, and the formulas shown can be derived from straight forward nodal analysis of the circuit. Similar formulas can be derived for the more complicated output amplifier. From these, using Thevenin's theorem, the gain of the tandem combination can be computed, as well as the feedbacks on the various tubes.

Similarly the input amplifier can be replaced, for convenience in reflection coefficient calculations, by the pi of admittances and the driving current of Fig. 10(b). The formulas of Fig. 10(b) expressed in terms of the co-factors of the circuit determinant are of general application for the reduction of a multi-node circuit to simpler form.

## REGULATING NETWORK

Like the coupling networks, the regulating network between the amplifiers is outside the feedback loops, and the gain of the amplifier is very nearly a direct function of the impedance seen looking into the network. This impedance is controlled by a single variable resistance — the thermistor — which is directly heated by the dc output current of the regulator. The output of the regulator, in turn, is a function of the

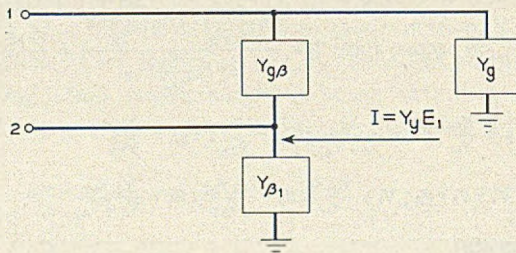

$$Y_g = \frac{\Delta_{22} - \Delta_{21}}{\Delta_{12-12}} = Y_1$$

$$Y_{\beta_1} = \frac{\Delta_{11} - \Delta_{21}}{\Delta_{12-12}} = Y_2 + \sigma_3 + \sigma_4 + P_3 S_2 P_4$$

$$Y_{g\beta} = \frac{\Delta_{21}}{\Delta_{12-12}} = Y_{12}$$

$$Y_y = \frac{\Delta_{12} - \Delta_{21}}{\Delta_{12-12}} = - \left[ P_{32} S_1 + \frac{S_1 S_2}{Y_{33}} P_4 \right]$$

WHERE THE CO-FACTOR  $\Delta_{12-12}$  IS FOUND BY STRIKING OUT THE FIRST AND SECOND ROW AND FIRST AND SECOND COLUMN OF THE CIRCUIT DETERMINANT, THE SIGN FOLLOWING THE USUAL RULES FOR THE SIGN OF A CO-FACTOR

Fig. 10 (b) — Equivalent circuit of input amplifier as seen by coupling network.



magnitude of main pilot level at the output of the amplifier. The whole forms an AVC circuit which acts to keep the level of the main pilot constant at amplifier output, under the assumption that any changes in this pilot level are caused by line temperature or length deviations. The invariant arms of the regulating network are designed to give the accurate shaping of network impedance versus frequency required so that the amplifier gain change will have the wanted square-root of frequency shape. The design of the network is fundamentally based on the variable equalizer theory developed by H. W. Bode,<sup>5</sup> but the process of finding physical networks which will give the desired performance to a very high order of accuracy makes use of newer methods developed by S.

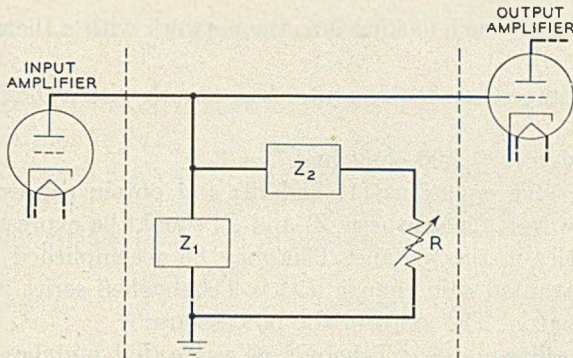

Fig. 11(a) — Regulating network block schematic.

Darlington.<sup>6, 7</sup> Since these methods were also used in the design of several other amplifier networks, and because the precision thus made possible is essential to the system, a brief recapitulation of the steps involved is of interest.

Fig. 11(a) shows the basic configuration of the regulating network. It was selected because it is one of the simplest that gives symmetrical gain changes controlled by a single resistor. It is also capable of absorbing the parasitic interamplifier capacity, and gives some advantageous gain shaping at normal setting, although this shaping is not under design control.

We need to find the impedance of the two arms  $Z_1$  and  $Z_2$ , that will give the required square-root of frequency shape of gain change (with a value of 6 db at 8 mc) as the thermistor is varied by a factor of three. For this circuit the change in gain may be expressed as a ratio of two impedances.



$$e^{\alpha+pb} = \frac{Z_H}{Z_N} = \frac{\frac{1}{Z_1} + \frac{1}{Z_2 + R}}{\frac{1}{Z_1} + \frac{1}{Z_2 + kR}} = F(p) \quad (1)$$

$$e^{-\alpha-jb} = \frac{Z_L}{Z_N} = \frac{\frac{1}{Z_1} + \frac{1}{Z_2 + R}}{\frac{1}{Z_1} + \frac{1}{Z_2 + \frac{R}{k}}} = \frac{1}{F(p)} \quad (2)$$

where:

$Z_N$  is the impedance looking into the network with a thermistor value  $R$

$Z_H$  is the impedance looking into the network with a thermistor value  $kR$

$Z_L$  is the impedance looking into the network with a thermistor value  $R/k$

For this design  $R = 500$  ohms and  $k = 3$

We may solve equations (1) and (2) and obtain expressions for  $Z_1$  and  $Z_2$ . However, for synthesis  $Z_1$  and  $Z_2$  should be expressed in terms of singularities in the  $p$ -plane. This may be accomplished by approximating the wanted gain change with a Tchebycheff series as developed by S. Darlington. The steps in the process are:

1. The coefficients of a Tchebycheff series that matches the desired gain change over the frequency band of interest are found:

$$\alpha = C_0 + C_2 \cos 2\phi + C_4 \cos 4\phi \cdots C_{2n} \cos 2n\phi \quad (3)$$

where the relation between  $\omega$  and  $\phi$  is given by the band-pass transformation

$$\omega^2 = K \frac{k_1 + \sin^2 \phi}{k_2 - \sin^2 \phi}$$

$$K = \omega_{c1}\omega_{c2}$$

$$\omega_{c1} = K \frac{k_1}{k_2} \text{ lower cutoff frequency (.2 mc)}$$

$$\omega_{c2} = K \frac{k_1 + 1}{k_2 - 1} \text{ upper cutoff frequency (8.35 mc)}$$

and

$$C_{2k} = \frac{2}{n+1} \sum_{r=1}^{r=n+1} \alpha_r \cos 2k\phi_r \quad \begin{array}{l} k = 1, 2, \dots, n \\ r = 1, 2, \dots, n+1 \end{array}$$

(Match points)



$$\phi_r = \frac{(2r - 1) \pi}{(2r + 1) 2}, \quad \alpha_r = \text{gain at } \phi_r$$

2. The coefficients of a related power series are determined:

$$e^{2\alpha} = 1 + A_2 Z^2 + A_4 Z^4 + \cdots + A_{2n} Z^{2n} \equiv F(Z^2) \quad (4)$$

where

$$A_2 + S_2 = 0 \text{ and } S_{2k} = kC_{2k}$$

$$2A_4 + A_2 S_2 + S_4 = 0$$

$$nA_{2n} + A_{2n-2} + \cdots = 0$$

3.  $F(Z^2)$  is expressed as a rational fraction containing both natural modes and infinite loss points.

$$F(Z^2) = \frac{N(Z)^2}{D(Z)^2} \quad (5)$$

where the coefficients of  $N$  and  $D$  may be found from the continued fraction expansion of  $F(Z^2)$ . The degree of  $N$  and  $D$  fixed by the allowable approximation error and the complexity of the network.

4. The roots of  $N$  and  $D$  (in terms of  $Z^2$ ) are found and then transformed to the  $p$ -plane using the transformation

$$p_\sigma^2 = K - \frac{2K(k_1 + k_2)}{\psi + 2k_2 - 1} \quad \text{where} \quad \psi = \frac{1 + Z^4}{2Z^2} \quad (6)$$

These four steps result in a polynomial  $F(p)$  satisfying the requirements on the change in gain. In this specific case

$F(p) =$

$$\frac{1.06(p + 0.0960)(p + 0.0280)(p + 0.9890)(p + 0.2890)}{(p + 0.1058)(p + 1.803)(p + 0.0300)(p + 0.3492)} \doteq e^{\alpha + j\beta} \quad (7)$$

Solving (1) and (2) obtain

$$Z_2 = \frac{k - F}{kF - 1} R, \quad Z_1 = \frac{(k^2 - 1)(F^2 - 1)}{(kF - 1)(k - F)} \quad (8)$$

where  $F(p) \equiv F$

Since the design must absorb the interstage capacities, (and also the stray capacities of some of the elements in the physical network)  $Z_1$  must include a shunt condenser. It can be shown that the desired result is obtained when

$$F \rightarrow 1 + g \frac{1}{p} \text{ as } p \rightarrow \infty \quad (9)$$



Since the derived transmission function  $F$ , equation (7), does not satisfy the condition expressed by (9), the function must be modified in order to provide a shunt condenser in  $Z_1$ . To accomplish this we use equation (5) expressed as a bi-linear form of the  $n$ th term of the continued fraction expansion.

$$F(Z^2) = \frac{N_1(Z^2) + K_n N_2(Z^2)}{D_1(Z^2) + K_n D_2(N^2)} \quad (10)$$

The coefficient  $K_n$  is modified so that the new  $F(p)$  satisfies equation (9). The modification of  $K_n$  does not substantially alter the required in-band transmission and also does not produce non-physical singularities. The new  $F$  obtained is

$$F(p) =$$

$$\frac{(p + 0.0289)(p + 0.1018)(p + 0.3431)(p + 1.017 \pm i 1.628)}{(p + 0.0310)(p + 0.1132)(p + 0.4426)(p + 0.6158 \pm i 1.368)} \quad (11)$$

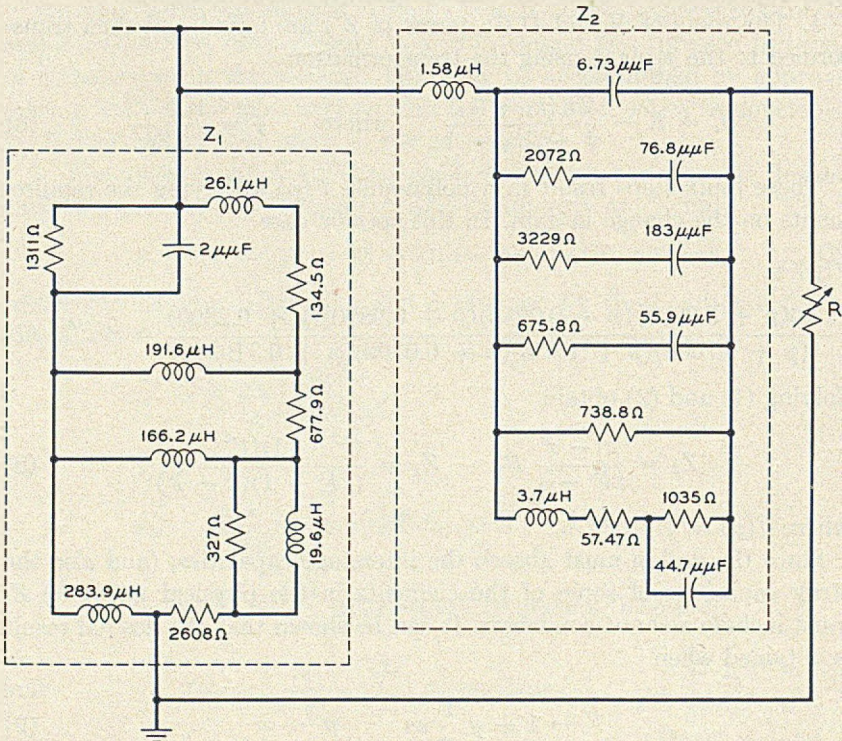

Fig. 11(b) — Regulating network schematic.



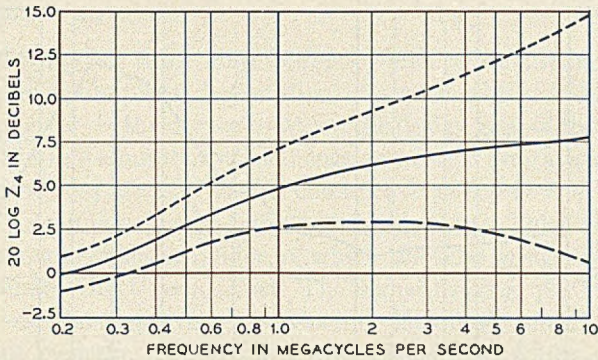

Fig. 12 — Relative gain of regulating network for extreme and mid-range thermistor settings.

By using this result in equation (8) expressions for  $Z_1$  and  $Z_2$  were obtained from which the configuration that is shown in Fig. 11(b) was synthesized.

Fig. 12 shows the voltage which would be developed across the regulating network versus frequency in response to a constant current driving force, for the mid-range and extreme values of thermistor resistance. The slope across the band for the mid-range value of 7.5 db; this is the regulating network contribution to the total slope of 37 db required of the complete amplifier.

To the extent that the differences between the curves of Fig. 12 fail to exactly match the desired square-root of frequency characteristic, the action of the regulating network will introduce an equalization error. This regulation error is shown in Fig. 13. It amounts to a few hundredths of a db for a six db gain change, caused in part by network design imperfections and in part by the fact that very small second order effects result in the amplifier gain not exactly following the regulating network impedance.

## BETA CIRCUITS

Starting from our basic requirement that a slope of 37 db across the transmitted band must be obtained, and noting that the total of the contributions from the coupling networks and regulating network is 16 db, we are left with about 20 db of shaping to be supplied by the beta circuits. The input beta circuit has been designed to supply most of this remainder, the contributions of the output beta circuit and the  $\mu\beta/(1 - \mu\beta)$  effects in the amplifiers being only three db. The original design procedure for this network was basically the same as for the



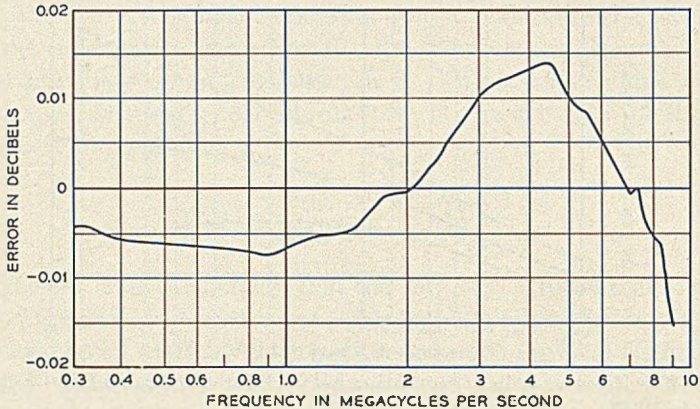

Fig. 13 — Regulation error per one db regulation.

regulating network, but the final values of the elements represent a long process of incorporating secondary corrections as our knowledge of the amplifier grew. Original constraints included the necessity of including as part of the beta circuit not only the relatively large parasitic capacity of the amplifier and the coupling network shield to shield capacity, but also the screen resistor and by-pass condenser of the second tube, which as usual is by-passed not to ground but to cathode, for modulation reasons. It is also required that the beta circuit have the correct dc resistance to serve as the cathode bias resistor of the second tube, and that it incorporate provision for metering this bias through suitable decoupling elements which are among the gain-determining elements of the network. Finally, this network was used as the mop-up equalization network of the amplifier, and its element values were readjusted to give the correct amplifier gain after the performance of a representative group of amplifiers with average coupling networks and tubes had been determined. In doing this tailoring, it is necessary to precorrect for the effects of non-infinite feedback, since the gain of the amplifier is not exactly a direct function of the beta circuit admittance. The configuration of the input beta circuit is shown by Fig. 14; it is a simple two terminal network. Its in-band impedance varies from about 1,000 ohms at 300 kc to 110 ohms at 8.35 mc.

The output beta circuit is relatively flat, which in this case is the optimum condition for signal-to-noise and feedback loop stability considerations. Because of this simplicity, it is possible to incorporate in this network provision for adjusting the gain of the amplifier to reduce the misalignment of the system.



## MISALIGNMENT ADJUSTMENT

We can distinguish three major effects which will contribute to misalignment and consequent degradation of system signal-to-noise ratio. One is design error — the degree to which the design gain of the amplifier, because of the finite number of elements and other limitations, fails to match the line loss. Second is the cumulative effect in the individual amplifier of manufacturing deviations of the elements. Third is the aging of the components of the amplifier, of which the tube aging will of course be the dominant short term effect. The signal-to-noise performance of the system can be improved by reducing the misalignment, if this is done without resorting to measures which would introduce systematic instead of random gain deviations.

If we study the shapes of gain change introduced by the more important deviation contributors, particularly the element variations, we find as might be expected that in general the effects are small at low frequencies and increase sharply near the upper edge of the band if the thermistor is held constant. In the system, the regulation around the main pilot will automatically act to reduce the deviation at 7 mc to zero, adding a square root of frequency curve that results in a bow shaped deviation as illustrated by Fig. 15. Examining the signal-to-noise effects of the degradation caused by misalignment, we conclude that it is most desirable to reduce as much as possible the misalignment at 4 mc, the television carrier frequency in the combined system. The output beta circuit has, therefore, been designed to give varying amounts of this shape, the total range being  $\pm 0.6$  db at 4 mc in 0.2 db steps. The successive steps of this gain adjustment are simple multiples of each other, symmetrical in the two directions of adjustment, so that we put into

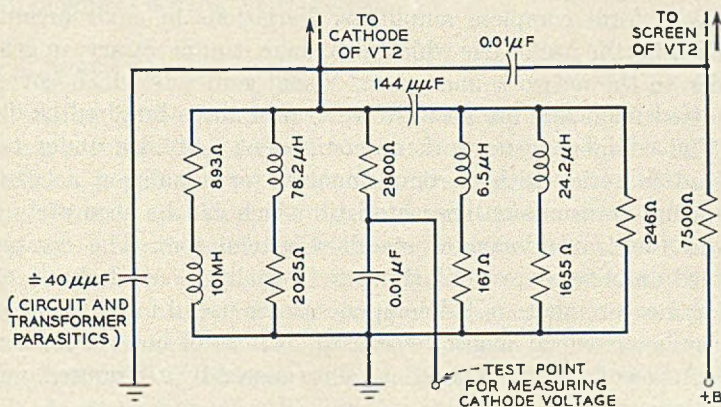

Fig. 14 — Input beta circuit elements — line amplifier.



the system a single systematic shape, which will be small in magnitude at the equalizing points because the different settings of this control in successive line repeaters will tend to cancel out. This setting of output beta circuit gain is controlled by a GAIN ADJ switch accessible from outside the amplifier housing. The adjustment will be made on an in-service basis as part of normal maintenance procedures, using the level at each repeater of one of the system pilot frequencies (3,096 kc) as the index of proper setting.

### MANUFACTURING TESTING

As mentioned above, the mechanical design of the amplifier has been planned to permit the separate testing of the five gain-determining net-

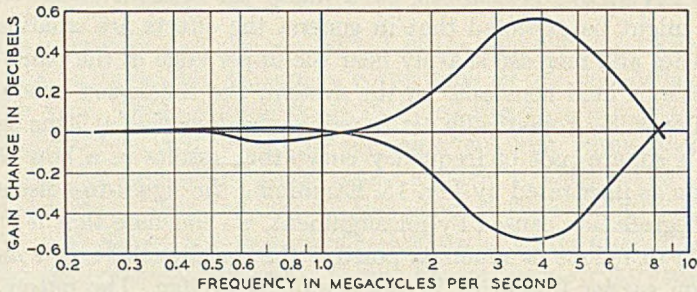

Fig. 15 — Amplifier gain versus output beta circuit misalignment adjustment.

works, the tuned interstage of the input amplifier, and the separate input and output amplifiers before their assembly with the regulating network to form complete amplifiers. Variations in environment are minimized by the use of jigs which also make it unnecessary, in general, to solder to the network under test. Visual gain sets which cover the transmitted band and are accurate to two or three hundredths db are used. The component network or component amplifier under test is connected in series with a complementary or equalizing network to obtain a flat transmission characteristic which can be accurately compared to the transmission of standard attenuators. The completely assembled amplifiers are similarly tested. Quality control charts of the resulting measurements on all components are useful in detecting shifts in transmission which might be caused by loss of control in element manufacture or by shifts of element values caused by subsequent damage in handling.



## DC FEEDBACK

In addition to the loop feedback at signal frequencies, local dc feedback is used on each stage. The grid of each tube is returned to a +9-volt potential rather than to ground, and about +10 volts is developed across each cathode resistor. The usual stabilizing effects of self-bias are thus obtained in exaggerated degree, each tube having about 20 db of local dc feedback. Care must then be taken to select the cathode by-pass and interstage coupling condensers so that the transition from low-frequency local feedback to in-band loop feedback is accomplished smoothly without the instability which might be caused by a balancing out of these two feedbacks in the transition region.

For maintenance measurements, the 9-volt bias potential and the dc cathode voltage of each tube are brought out to a multi-pin amplifier test jack through appropriate decoupling filters. Thus the bias on each stage can be measured on an in-service basis. Filament voltage dropping resistors which can be switched in or out of circuit are provided on the repeater panel, so that bias can also be observed for a filament supply voltage 10 per cent below normal. The activity or change in plate current with filament voltage thus measured, or the history of the bias at normal filament voltage, will be used to determine when amplifiers should be taken out of service for tube replacement.

The upper triode is, of course, a special case: since it is the plate supply path for the lower triode, its cathode is about 160 volts above ground and its grid is returned to a similarly high potential. About 35 db of dc feedback is obtained on this stage; the same provisions for measurement of bias and activity are made. To avoid excessive filament to cathode voltage, a separate filament winding which floats at the +190-volt supply potential is used for this tube.

## LOOP FEEDBACK

The design of the feedback loops of the input amplifier follows conventional practice. The constraints which operate to limit the amount of feedback which can be obtained in the transmitted band are well known.<sup>8</sup> Broadly speaking, the figure of merit of the vacuum tubes and the circuit capacities determine the asymptotic cutoff, which in any feedback amplifier limits the magnitude of the feedback which can be built up in the band. In multi-loop structures, there are additional limitations. Consider, for example, the formula given on Fig. 10(a) for the feedback on the second tube. If we increase without limit the magnitude of the first tube transconductance, we find that the feedback



on the second tube approaches the value  $S_1 P_4 Z_{32}$ . This is a limit, common to multi-loop structures, over and above the usual limit imposed by the Nyquist stability criterion. A similar  $S P Z$  limit can be derived for the feedback on each stage. The same multi-loop mechanisms which operate to limit the feedback also result in making the feedback on any given stage relatively insensitive to variations in other transconductances or impedances. In a single loop circuit a one db change in beta circuit impedance or first stage transconductance causes a one db change in the feedback on every tube. Here the feedback on, say, the second stage would generally change only one-half db at most frequencies. While this is an advantage in the sense that transconductance decay does not decrease feedback as rapidly as it would in a single-loop amplifier, it is a disadvantage in that it militates against improving stability margins by shaping the out-band impedance of the beta circuit.

The capacity distributions within the input and output amplifiers are such that while the  $S P Z$  limitations on feedback are closely approached, the most stringent limitation on the feedback obtained is the Nyquist criterion.

The use of the Nyquist criterion, particularly with respect to defining the margins against singing, is likewise complicated by the multi-loop nature of the circuit. Ignoring some very recent work, the implications of which have not been fully explored at this writing, it can be said of a multi-loop structure that the apparent margins against singing shown by any plot of feedback give no certain information as to how safe from singing the circuit is. The phase, as well as the magnitude, of the feedback on each stage is a function of the magnitude of the other transconductances, and either decay or increase of these transconductances might destroy the phase margin. In these circumstances, it is theoretically necessary to examine for stability every conceivable combination of transconductances. A more practical expedient, of course, is to rely on judgment backed by computation and laboratory experiment on the circuit for a wide but far from infinite number of circuit conditions.

Another difficulty arises from the fact that the feedback on each tube is different, so that gain and phase margins obtained for one return ratio do not imply equal gain and phase margins for the return ratio on some other tube of the same amplifier. It does not follow, however, that it is necessary to investigate separately the margins on each stage versus circuit element variations. The point to be stressed here is that we are using the behaviour of the return ratio merely as an index of our real concern: the position on the  $p$ -plane of zeros of the determinant of the circuit, and the determinant is the same for both stages. Rather



than asking how many db of gain margin and how many degrees of phase margin any particular return ratio displays, we ought instead to inquire how quickly the apparent margins disappear as we change transconductances and network impedances. The margins on all the return ratios will vanish simultaneously, regardless of the apparent difference in original margin magnitudes. It is therefore satisfactory to examine the behaviour of whichever return ratio is most easily observed.

The design choices made in arriving at the coupling network also affect the magnitude and shape of the feedback which can be obtained: as mentioned above, the relative magnitude of the impedance seen looking into the coupling network and the impedance from first tube grid to ground determines how much of the voltage developed across the beta circuit will reach the first stage as a driving force.

Study of the modulation products which will arise in system operation, both for the all telephone case and for the combined telephone-television signal, led to the conclusion that optimum shaping of the feedback for the L3 system would be to maximize the feedback at low frequencies in order to suppress intermodulation products falling in that part of the spectrum in the combined telephone-television case. Shaped feedback, falling off at the higher frequencies, is also consistent with obtaining a smooth and simple shape of gain-change as tubes age (known as "mu-beta effect"), which is desirable from the equalization standpoint. With these considerations in mind, the interstage of the input amplifier has been peaked well above the transmitted band — at 11 mc — to partially compensate for the input potentiometer term, and to help in achieving this smooth shape of mu-beta effect. If flat feedback over the band were the objective, it would also be necessary to design the grid-cathode admittance of the second tube so that the parasitic grid-cathode capacity would be absorbed in a flat impedance versus frequency, but in this case the desired shaping of the second tube feedback is attained by taking advantage of the way in which the grid-cathode capacity naturally limits the high-frequency feedback on this stage.

The loop feedback in the output amplifier is similarly shaped, for the same modulation and equalization reasons. The use of the double triode circuit in this amplifier is an unusual feature. This connection of two triodes, sometimes referred to as the "cascode circuit," has appeared in many contexts in recent years, usually to serve some other purpose than here. It serves as a superior output stage in the L3 amplifier largely because the effective transconductance which can be obtained is about 3 db higher than that of a pentode of the same grid-cathode spacing. The effective transconductance, ignoring for the moment the division of out-



put current between the load impedance and the internal plate impedance of the upper triode, is very nearly the transconductance of the lower triode. Since no current is lost to a screen, this is higher than that of a pentode of the same spacing. The output impedance of the upper triode is multiplied by the local feedback consequent on its cathode being off ground by the plate impedance of the lower triode. Since the load presented to the lower triode is a low impedance, approaching the reciprocal of the transconductance of the upper triode, the grid-plate capacity of the lower triode is not enhanced by feedback. The higher value of transconductance means less grid drive for the same output current, and more obtainable feedback, both contributing to superior modulation performance.

The modulation of the upper triode, and the changes in transconductance of this tube, are suppressed by approximately the sum, in db, of the local and loop feedback. In consequence, the modulation and mu-beta effect contributions of this tube to the complete amplifier are negligibly small.

It will be observed that the grid of the upper triode is not connected to ground, but to the top of the beta circuit. In consequence, the grid-plate capacity of the upper triode appears as part of the end-capacity of the coupling network rather than as a parasitic capacity to ground. This results in a gentle potentiometer term in the output amplifier. This connection, however, also has the effect of vitiating to some extent the desirable qualities of the circuit, particularly at the higher frequencies, where the grid-cathode capacity of the upper triode becomes important.

Because of this gentle output potentiometer term, it is not necessary to tune the interstage of the output amplifier, which consists simply of the circuit capacity plus a network which has the characteristics of a 10-mmf capacity in the transmitted band. Above the band this network shapes the gain and phase characteristics of the feedback loop to obtain the desired stability margins. The incorporation of this network reduces the in-band feedback by about 3 db, a sacrifice which unfortunately is necessary to assure stability when the thermistor in the regulating network is at its minimum value. For this value of thermistor, the phase and magnitude relations of the regulating network impedance and the grid to cathode capacity of *VT3* produce a potentiometer term in the feedback loop which appreciably reduces the margins around 30 mc. The stability margins for the mid-range value of thermistor would be satisfactory without this sacrifice of in-band feedback. When the thermistor is at maximum resistance, some degradation of phase margin at 10 mc occurs, again because of the potentiometer term effect mentioned above,



but in this case the remaining margin is sufficient, since the circuit elements are still under good control at this frequency. Because the plate-cathode impedance of *VT2* is very high, the similar potentiometer term at the output of the input amplifier causes only negligible changes in input amplifier stability margins as the thermistor changes.

In the 70-mc region there are two almost equally important feedback loops in the output amplifier — one through the transconductance of the lower triode, the other through the grid-plate capacity of this tube. Balances between these feedback paths are observed in the 70 to 100-mc region in the course of measuring the feedback, sometimes accompanied by 180° shifts in the phase of the loop transmission at frequencies above the balance point, an effect which theoretically depends on just how the two vectors go through the balance point. The occurrence of these balances is accompanied by a few degrees loss of phase margin in the 30-mc cut-off region, which must also be allowed for in setting the 30-mc stability margins, since sufficient control of parasitics to prevent these 70-mc effects is out of the question.

Parasitic resonances between the lead inductances and the capacities of the circuit, which tend to cause instabilities in the very high-frequency region about 200 mc, are damped by small resistors in the leads, and the lead inductances are kept small by careful mechanical design. In this frequency region, neither measurement nor computation of stability margins can be trusted as anything but a rough guide. On the other hand, adding damping resistors in grid leads and other critical points to prevent 200-mc sings causes a phase margin penalty in the 30-mc region, so a nice judgment of how much damping to add is called for. Final values of damping were chosen so that typical amplifiers could not be made to sing by increasing critical lead lengths or by substantial increases in parasitic capacity, thus assuring that manufacturing variations of elements and wiring will not cause high-frequency sings. The return ratio of *VT4* is shown on Fig. 16, the mu-beta effects of both amplifiers on Fig. 17.

#### SIGNAL LEVELS, MODULATION, AND NOISE

Fig. 18 shows the signal levels within the amplifier in db relative to one volt from grid to cathode of *VT4*, which is a convenient point to use as a reference for system signal-to-noise studies. It will be noted that as a result of using the input beta circuit to give so much of the shaping of amplifier gain, the input amplifier has little gain at low frequencies. In consequence the input tube of the output amplifier and the regulating network are important thermal noise sources at low frequencies. The



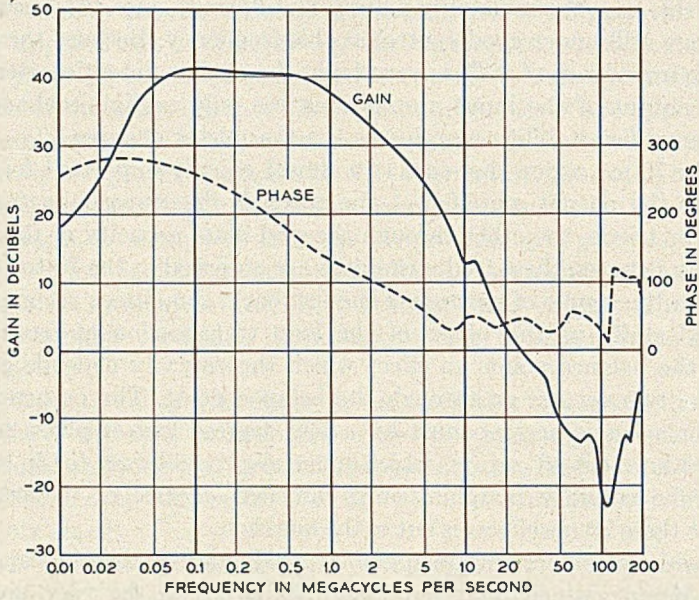

Fig. 16 — T4, return ratio of lower triode.

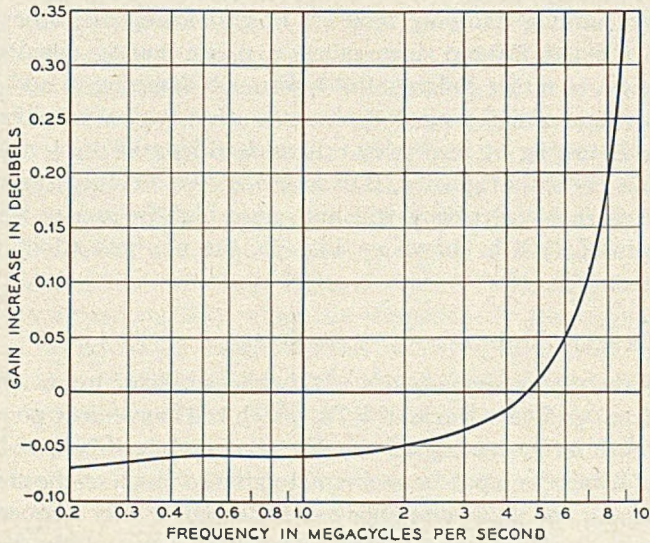

Fig. 17 — Mu beta effect, amplifier gain change for a one db decrease in each transconductance.



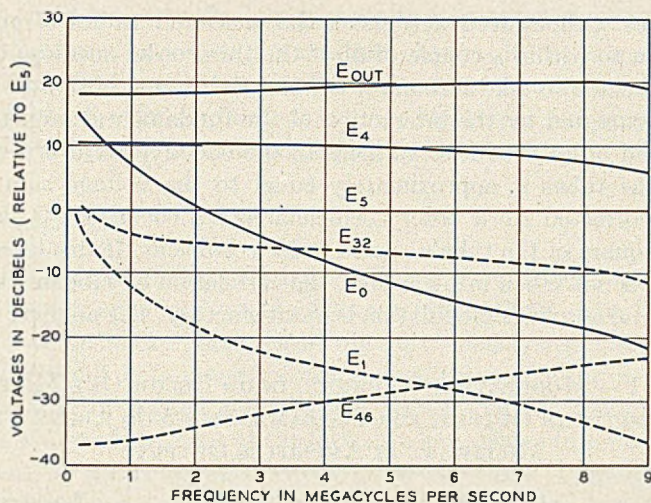

Fig. 18 — Relative levels of signal voltages in line amplifier referred to voltage at grid of lower triode. Thermistor at mid-range value.

relative magnitudes of the noise sources are shown on Fig. 19, which gives the noise at amplifier output as a function of frequency.

Comparison of the grid to cathode voltages of  $VT_2$  and  $VT_4$  shows that the former will be an important modulation contributor, since the driving force on these tubes is nearly equal, particularly at low frequencies. Typical amplifier modulation values are given in Table III. Computations using the measured feedback and the performance of

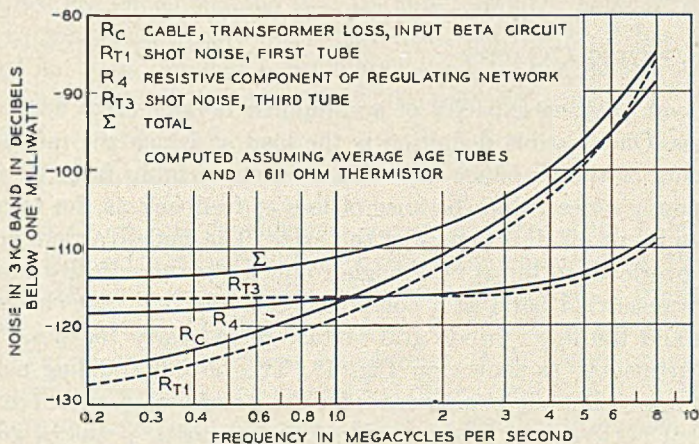

Fig. 19 — Thermal noise at line amplifier output.



single tubes without feedback check the measured values of amplifier modulation to within a couple of db if the third order coefficient of the tube is corrected to take account of the fact that some third order modulation is generated by the interaction of the fundamentals and the feedback second order products. In general, the effective third order coefficient of the tubes is approximately equal to the voltage sum of the tube's uncorrected third order coefficient and a coefficient 6 db worse than the square of the tube's second order coefficient. If this interaction correction is not taken into account, the correlation of tube modulation, feedback and amplifier modulation is unsatisfactory. The analysis leading

TABLE III — MODULATION PRODUCTS, IN db BELOW ONE MILLIWATT AT AMPLIFIER OUTPUT, FOR FUNDAMENTALS 5 db ABOVE ONE MILLIWATT AT AMPLIFIER OUTPUT

Type	Fundamentals Mc	Product Mc	Product - dbm
2F	0.5	1.0	72
	1.0	2.0	65
	3.0	6.0	55
	4.0	8.0	51.5
3F	0.25	0.75	95
	0.667	2.0	97
	2.0	6.0	87.5
	2.66	8.0	81.5

to this result, which is due to F. B. Llewellyn, S. E. Miller and R. W. Ketchledge, is too long to give here.

#### LOAD CARRYING CAPACITY

The load carrying capacity of an amplifier is difficult to define with exactness. One possible definition is the load at which the modulation coefficients of the amplifier have departed appreciably from the small signal power series values because of loss of feedback as the transeconductance is cut off during part of the cycle. The signal carried without serious overload, in terms of a single frequency, is practically constant in the transmitted band as a consequence of the fact that the output voltage and the lower triode grid voltage have nearly the same shape versus frequency, as shown on Fig. 18. The output coupling network shaping approximately compensates for the potentiometer term division of current between the load impedance and parasitic paths to ground. Departure from the small signal power series behaviour just begins to



be appreciable at +14 dbm of any single frequency. At +18 dbm the dc effects of overload show up as slight changes in the transmission of the pilot frequencies. At +26 dbm, the second order modulation is 3 db, the third order modulation is 6 db, higher per line amplifier than would be predicted from small signal behaviour.

#### FLAT AMPLIFIER

The flat gain amplifier, which is used as a transmitting amplifier and to make up for equalizer loss at various points in the system, is basically the same as the line amplifier, with only the obviously necessary modifications. The input beta circuit is nearly flat, the regulating network has been replaced by a fixed gain network which contains a single variable element whose adjustment at the factory compensates to some extent for variations in the coupling networks, and the input coupling network has been modified so that the peaking used in the line amplifier is replaced by a drop in the high-frequency gain of this network. The output beta circuit has been modified to give flat gain control of  $\pm 1.0$  db in 0.2 db steps. The interstage designs are changed to readjust the feedback so that the modulation suppression and the change in gain as tubes age will be nearly the same as in the line amplifier. Somewhat more feedback is obtained in the output amplifier since no network is needed in the output amplifier interstage to adjust the 30-mc phase for an unfavorable regulating network setting.

The nominal gain of the flat gain amplifier has been set at 34 db and is flat to within  $\pm 0.2$  db over the transmitted band. The amplifier circuit capacities are low enough so that the inter-amplifier network could be built to give considerably more gain than this; the limit has been set so that flat gain amplifier noise contributions to the complete system noise will not exceed about 1.0 db at the television carrier.

#### ACKNOWLEDGEMENTS

As in any corporate development, many members of the Laboratories have made important contributions to the L3 amplifier design. Particular mention should be made of the work of S. E. Miller on fundamental amplifier design, S. Darlington and T. R. Finch on network design, C. W. Thulin on the precision transformer, B. J. Kinsburg on quality control problems, E. Ley on mechanical design, and E. F. O'Neill on the flat gain amplifier and on high-frequency stability problems in both amplifiers.



## REFERENCES

1. C. H. Elmendorf, A. J. Grossman, R. D. Ehrbar, R. H. Klic, The L3 Coaxial System — System Design, see pp. 781 to 832 of this issue.
2. R. W. Ketchledge, T. R. Finch, The L3 Coaxial System — Equalization and Regulation, see pp. 833 to 878 of this issue.
3. G. T. Ford and E. J. Walsh, Electron Tubes for a Coaxial System, Bell Sys. Tech. J., Oct. 1951, Part II.
4. H. W. Bode, Coupling Networks, U. S. Patent 2337965, Dec. 28, 1943.
5. H. W. Bode, Variable Equalizer, Bell Sys. Tech. J., April, 1938.
6. Sidney Darlington, The Potential Analogue Method of Network Synthesis, Bell Sys. Tech. J., April, 1951.
7. Sidney Darlington, Network Synthesis Using Tchebycheff Polynomial Series; Bell Sys. Tech. J., July, 1952.
8. Hendrik W. Bode, Network Analysis and Feedback Amplifier Design, D. Van Nostrand, 1945.



# The L3 Coaxial System

## Television Terminals

By JOHN W. RIEKE and R. S. GRAHAM

(Manuscript received April 17, 1953)

*Television terminals are required at circuit ends of the L3 coaxial system; at the transmitting end to condition video signals for carrier transmission and at the receiving end to detect the transmitted signals. Special signal characteristics, e.g., a degree of modulation which exceeds the value commonly referred to as 100 per cent modulation, require departures from standard modulating and detecting processes. The high degree of modulation requires both careful control of transmitted wave form and at the receiver product demodulation with phase synchronous carrier (homodyne detection).*

*Carrier regeneration requirements result in the choice of one step frequency translation from the video frequency spectrum to the allocated vestigial sideband carrier spectrum. The one step process using a single modulator results in unusual balance requirements for the modulator itself and an unusual circuit configuration.*

*Transmission quality objectives for the terminals are such as to permit six pairs of television terminals to operate in tandem in a transcontinental circuit. This permits a degree of interconnecting flexibility in operation with other systems, e.g., L1 coaxial or microwave systems. These objectives place severe requirements upon the transmission stability of various filters and other circuits within the terminals. New network techniques both in design and fabrication are brought to bear in the effort to achieve required performance.*

*The transmitting and receiving terminals are described, illustrating the functional operation and mechanical and electrical arrangements of the equipment.*

### INTRODUCTION

The main features of the L3 coaxial cable transmission system have been described in a companion paper.<sup>1</sup> This paper describes the television transmitting and receiving terminal equipment of the L3 system. The



transmitting terminal conditions a television signal for carrier transmission over the system simultaneously with a group of 600 telephone messages. The receiving terminal reconverts the carrier signal at each receiving point along the cable route. Primarily, the transmitting terminal is a modulator which translates the composite video picture spectrum of frequencies up to the carrier band of frequencies and the receiving terminal is a detector which retranslates the carrier spectrum back to its original band of frequencies.

Particular characteristics of the transmitted television signal, which are intended to aid in achieving optimum transmission quality, have necessitated the departures from past techniques in modulation and demodulation processes that are described in the following. Described also are the methods employed to achieve transmitted picture quality adequate for tandem operation of as many as six pairs of transmitting and receiving terminal equipments in a 4,000-mile television transmission circuit. Operation with several pairs of terminals in tandem occurs when L3 coaxial systems are interconnected with L1 coaxial systems or microwave radio systems.

L3 television terminal development has been in progress since early in 1948. Two transmitting and two receiving terminals have been built on a preproduction basis and currently are being tested under field conditions as part of the L3 system field trial. Development effort is continuing on the terminals with emphasis on equipment reliability, including means for maintaining and improving transmission quality.

#### FREQUENCY ALLOCATIONS

The L3 coaxial system was designed to have as broad a transmission band as the economics of repeater spacing together with presently realizable feedback amplifier performance permit.<sup>2</sup> The band extends from 300 kc to 8.5 mc. In comparison with this band a broadcast television signal occupies the frequency spectrum from zero frequency up to 4.5 mc.

From the foregoing it is evident that the television spectrum will not occupy fully the available system transmission band. It is feasible and attractive to allocate part of the transmission band for television transmission and the remainder for transmission of message channels. Detailed allocations then result from a compromise among transmission performance, cost and the number of message channels made available.

From these considerations vestigial sideband transmission of the television signal rather than double sideband transmission is called for. The smaller the vestigial band of transmitted frequencies is made the



smaller will be the total television band required. However, both the cost of band shaping filters and the difficulty of maintaining satisfactorily low values of vestigial sideband quadrature distortion increase as the vestigial band width is reduced. The compromise of these factors resulted in the choice of a 500-ke vestigial sideband.

Another choice made was to transmit the television signal in the upper part of the L3 band and the message channels in the lower part. This allocation was determined by considering the noise distribution in the transmission band together with the modulation distortion, (harmonic distortion), produced by the repeaters. By transmitting television in the upper part of the band a minimum modulation distortion is achieved since the harmonics of the television signal largely fall outside the transmitted band or at high frequencies where their effects in the picture are relatively less visible than low frequency distortion. This factor outweighs the higher noise level in the upper part of the band.

With respect to the television carrier location, it is placed at the bottom of the television band at 4.139 mc, with the vestigial sideband extending down to 3.64 mc and the main sideband extending upward to 8.50 mc. Alternatively the carrier could have been located at the top of the L3 band with a main lower sideband and vestigial upper sideband, but this choice would be disadvantageous because of higher noise levels and poorer repeater gain stability near the top edge of the transmitted band.

The final allocation of frequencies is shown in Fig. 1. Just below the television band from about 3 mc to 3.5 mc is a dead space. This frequency space is needed for the filters which are employed to separate the telephone signals from the television signals at television and telephone dropping points. A very high value of loss is required of these filters in their attenuating bands and if this is built up over too small a frequency

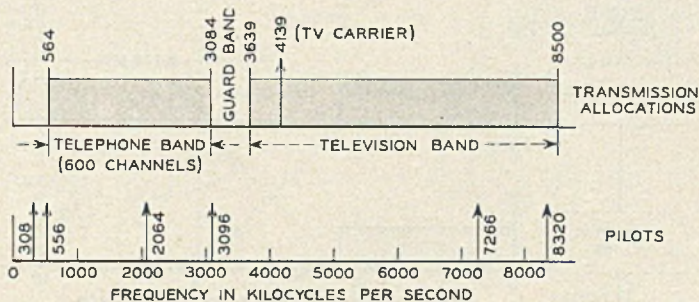

Fig. 1 — Frequency allocations for L3 combined television-telephone transmission.



band the resulting delay distortion introduced into the television band becomes very difficult and expensive to equalize. Below this "guard band" is the "master group" of 600 telephone channels which is transmitted simultaneously with the television signal.

The detailed allocation of specific frequencies, e.g., TV carrier and the pilot frequencies, results from consideration of effects produced by these frequencies in telephone channels as a consequence of modulation distortion in repeaters. These considerations are described in detail in the system design paper.<sup>1</sup>

### MODULATION PROCESS

In the L1 coaxial cable system<sup>3</sup> frequency translation by the television terminals is accomplished in two stages. The two step process employs a first modulator supplied with a very high frequency carrier to translate all video frequencies to a band far outside the final transmitted band of

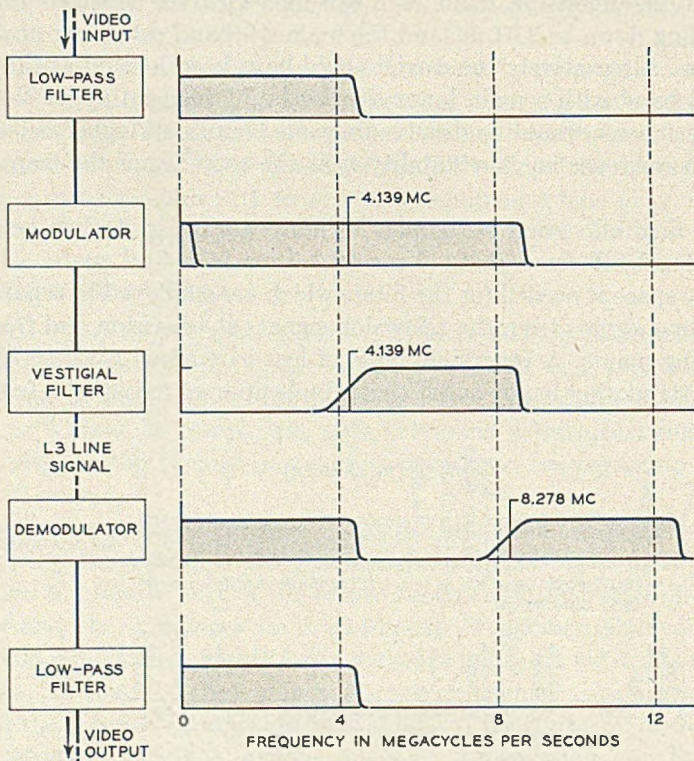

Fig. 2 — Television terminal modulation processes.



frequencies where the upper side band is suppressed. A second modulation then translates the vestigial sideband signal back down in frequency to the final band. In contrast the L3 terminals employ only a single step of modulation to convert the signal directly to the assigned band as shown in Fig. 2. In general this can be accomplished if the carrier frequency is at least half the sum of input and vestigial bandwidths. Then the lower modulation sideband does not fold over the zero frequency axis to produce frequencies which fall back into the vestigial or upper sidebands. Some foldover is evident in the L3 case shown in Fig. 2 at low frequencies of the modulator output. Single step modulation is advantageous in that the very high frequencies encountered in the multi-step process are avoided. The disadvantage of the one step process is that many extraneous products of modulation, which in the two step process can be suppressed with filters, must be reduced to tolerable levels by balances in the modulator.

The modulator, Fig. 3, is a combination of two double balanced modulators of a form often employed for modulation of telephone signals.<sup>4</sup> The effect of a double balanced varistor modulator of the type represented by either of the two in Fig. 3 is to multiply the input signal by a square wave function having the period of the particular carrier frequency. Since the square wave contains all odd harmonic multiples of

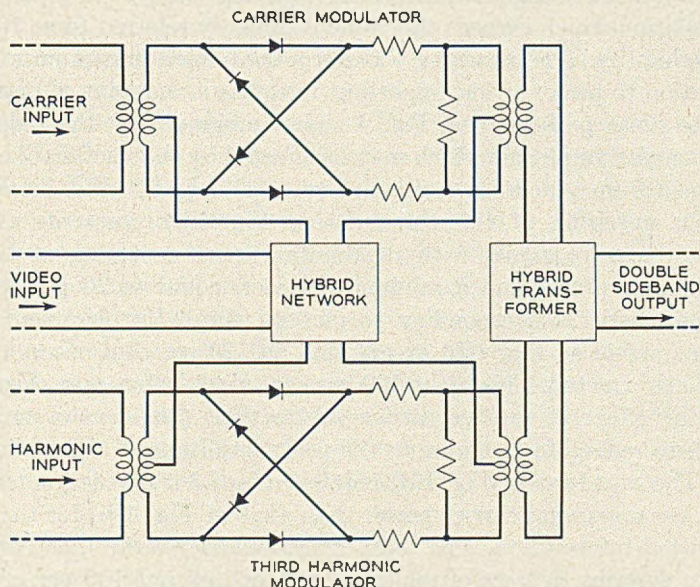

Fig. 3 — Modulator for L3 terminals with third harmonic carrier product balance feature.



the carrier frequency its multiplication by the input signal generates a series of double sideband output spectra, each centered about one of the harmonics of the carrier. It happens in this case that the lower sideband of the third harmonic spectrum of the carrier modulator contains frequencies low enough to overlap the high frequencies of the carrier spectrum upper sideband and this overlap results in quite visible picture distortion.

It is possible, by employing a second modulator paralleling the first but driven with a frequency three times the carrier frequency, to generate a signal spectrum centered at carrier third harmonic which will cancel the corresponding output of the carrier modulator. Successful translation of the video spectrum to the L3 carrier band in a single modulation step depends upon the maintenance of this and other modulator balances to unusually stringent requirements.

The carrier supply oscillators for the modulators and demodulators are of the Meacham bridge type<sup>5</sup> with quartz crystal frequency control and thermistor amplitude control. Frequency stability of two parts per million is required for successful carrier regeneration at the receiver. A constant temperature oven for the quartz plus the inherent stability of the bridge type circuit is expected to provide the required frequency stability between monthly maintenance periods.

A feature of the signal transmitted over the L3 system is a degree of modulation which exceeds the value commonly referred to as 100 per cent modulation. The resulting waveform contains a maximum ratio of information to peak carrier, important from the standpoint of optimum signal to noise performance. Fig. 4 shows progressively the reduction in peak carrier amplitude which may be effected by subtraction of carrier component from a modulated signal. Figs. 4(b), (c) and (d) each contain the same amplitude of video modulation. Fig. 4(b) represents a video modulated carrier signal with maximum carrier occurring at tips of synchronizing pulses and a minimum carrier, equal to 20 per cent of maximum carrier, corresponding to picture white. Fig. 4(c) represents the same signal as Fig. 4(b) except that the 20 per cent excess carrier has been subtracted. This is the 100 per cent modulation case. Fig. 4(d) shows the effect of further carrier subtraction, (addition of negative carrier), to reduce to a minimum the peak amplitude of the modulated signal. The waveform of Fig. 4(d) employed for L3 transmission requires  $7\frac{1}{2}$  db less maximum carrier power than that of Fig. 4(b) for the same transmitted information. The term "excess carrier ratio" has been devised to describe degrees of modulation which exceed 100 per cent. It is the ratio of peak carrier amplitude to the peak-to-peak modulation



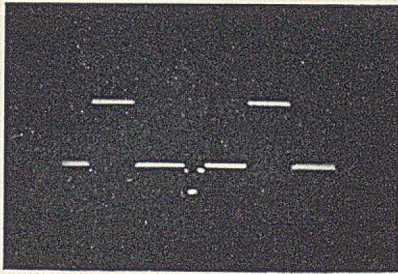

(a) VIDEO MODULATING SIGNAL

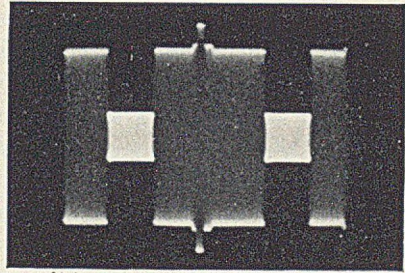

(b) EXCESS CARRIER RATIO EQUAL TO 1.2

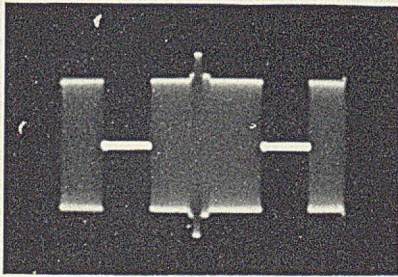

(c) EXCESS CARRIER RATIO EQUAL TO 1.0

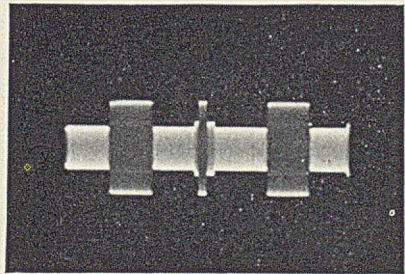

(d) EXCESS CARRIER RATIO EQUAL TO 0.5

Fig. 4 — Carrier waves variously modulated by a composite video signal.

amplitude. Excess carrier ratio, (ECR), for the waveforms of Figs. 4(b), (c) and (d), respectively, are 1.2, 1.0 and 0.5.

Modulated signals of the forms of Fig. 4(b) or 4(c) may be detected by rectification, i.e., envelope detection. However, rectification of the waveform, Fig. 4(d), produces a spurious envelope wherein video signals which exceed a particular value are inverted. It is necessary to employ homodyne detection, that is, a demodulator driven by a locally generated carrier which is synchronous in phase angle and frequency with the carrier component of the signal wave. As described later, homodyne detection also makes possible the necessary suppression of the quadrature distortion associated with vestigial sideband transmission. Quadrature distortion associated with envelope detection is tolerated in the L1 coaxial system but with tandem operation of terminals required in the L3 system, would accumulate to intolerable values.

#### VESTIGIAL SIDEBAND CONSIDERATIONS

A vestigial sideband signal is produced by a band shaping filter following the modulator. In this filter the lower sideband is suppressed com-



pletely except for those frequencies which are within 500 kc of television carrier. Lower sideband frequencies within 500 kc of carrier are suppressed only partly as also are upper sideband frequencies within 500 kc of carrier to achieve a symmetrical response function in the vestigial sideband region.

It is convenient in a discussion of vestigial sideband transmission to consider the transmission as made up of two components, each symmetrical about carrier frequency, a real or in-phase component and a quadrature component which is a distortion term.<sup>6</sup> The process is illustrated in Fig. 5. Here the response function shown in Fig. 5(a) represents idealized conditions for vestigial sideband transmission. The main sideband is shown extending from carrier frequency  $F_c$  to the upper cut-off  $F_u$ . A vestige of the lower sideband extends from carrier frequency to the lower cut-off  $F_v$ . Constant envelope delay is required in the entire band from  $F_v$  to  $F_u$ . In the frequency region  $F_c \pm F_v$  the response characteristic is so shaped that the sum of responses at corresponding frequencies above and below carrier add to a constant value. The summing of signal components in the vestigial bands above and below carrier is accomplished by the receiver demodulator.

The response function of Fig. 5(a) may be considered to be the sum of the two response functions 5(b) and 5(c) which have even and odd symmetry respectively about the carrier  $F_c$ . Both 5(b) and 5(c) are double sideband functions. The component in Fig. 5(b) represents the

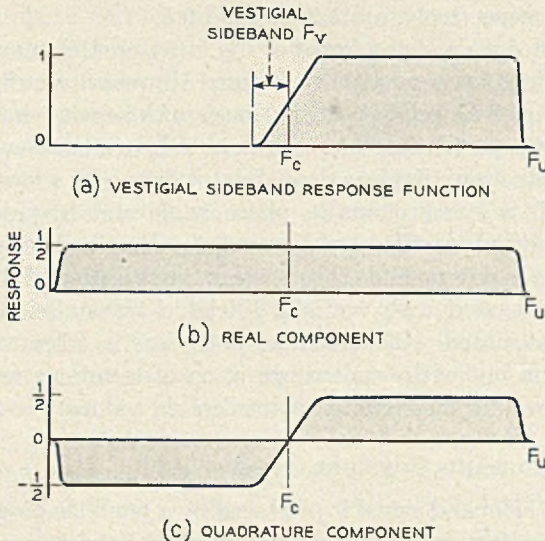

Fig. 5 — Response function of a vestigial sideband carrier system.



normal double sideband output of the modulator supplied with video and carrier signals. The other component, Fig. 5(c), represents the output of a modulator supplied with carrier and signal voltages each shifted in phase by  $90^\circ$  and with the amplitude attenuated as shown in the vestigial region  $F_c \pm F_v$ . The modulation transmitted by a circuit with the response function of Fig. 5(c) is called the quadrature component and is related to the normal modulation, depending upon the shape and extent of the vestigial sideband. Fig. 6 illustrates the real and quadrature components of an idealized rectangular wave form demodulated after transmission over circuits having the response functions of Fig. 5, respectively.

The  $90^\circ$  shift of carrier frequency in the quadrature component of the vestigial sideband signal makes possible the suppression of this component. The transmitted vestigial sideband signal may be written

$$V(t) = P(t) \text{Cos } ct + Q(t) \text{Sin } ct, \quad (1)$$

where  $c = 2\pi$  times carrier frequency and  $P(t)$  and  $Q(t)$  are "real" and quadrature modulating functions<sup>6</sup> typically as represented on Fig. 6.

The demodulator may be regarded as an ideal multiplier of signal and carrier supply. Let the carrier supply be denoted:

$$C(t) = \text{Cos } (ct - \phi), \quad (2)$$

where  $\phi$  is the phase of the receiver carrier supply relative to the carrier factor of the "real" component of the signal. The demodulator output is the product  $V(t) \times C(t)$ . A low-pass filter rejects the output components in the band of frequencies about twice carrier frequency so that the demodulated video signal output is the lower frequency component. Thus, neglecting a factor of  $\frac{1}{2}$ ,

$$V_0(t) = P(t) \text{Cos } \phi + Q(t) \text{Sin } \phi. \quad (3)$$

It is seen that real and quadrature video components in the demodulator

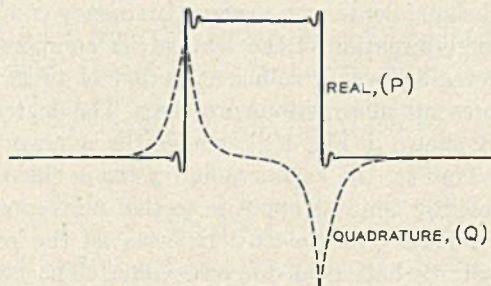

Fig. 6 — Real and quadrature components of a rectangular pulse after vestigial sideband transmission.



output exist in the same proportion as the components of the demodulator carrier supply in phase and in quadrature respectively with the real carrier component of the vestigial signal. By providing carrier exactly in phase with the real component of the signal the quadrature component in the output may be suppressed completely. It has been determined that to suppress the quadrature component resulting from the L3 vestigial band shape to barely perceptible (threshold) values the phase angle of the carrier regenerated at the receiver must be maintained to an accuracy of plus or minus 2.5 degrees. A requirement for one demodulator, when six pairs of terminals contribute to produce quadrature distortion at threshold value, becomes 2.5 degrees divided by the square root of six, or about one degree.

The regeneration of carrier at the receiver is one of the principal L3 terminal features. Here a 4.139-mc carrier must be provided to demodulate the "over-modulated" L3 signal. The required carrier must be reconstituted from information carried in the signal itself. It would be possible, of course, to transmit separately a signal from which carrier frequency could be derived but carrier frequency is really the smallest part of the required information. It is the phase angle of the carrier of the received signal which must be duplicated closely at the demodulator and separate transmission of carrier phase angle does not seem feasible. A phase controlled oscillator is employed for the carrier supply at the receiver, with phase control obtained from information residing in the signal itself and frequency synchronization an additional burden upon the phase control system.

The basis for synchronizing the receiver oscillator to the carrier of the received signal lies in the phase angle of the carrier frequency component of the vestigial sideband signal averaged over a period of time of the order of one frame scanning period. Referring to Fig. 5(b) and 5(c) again, it may be noticed that the quadrature response function is zero at carrier frequency. This means that the quadrature component of the transmitted signal contains no carrier frequency component and will not affect the determination of the real carrier component phase angle based upon averaging over a sufficient period of time. Another signal characteristic presents more serious problems. The degree of modulation employed in L3, shown in Fig. 4(d), makes the average carrier polarity indeterminate. That is, the carrier polarity for a video amplitude corresponding to picture white is opposite to that corresponding to picture black or sync pulses. The polarity reverses as the composite signal changes through its half peak-to-peak value. The average polarity determined from a predominantly white picture is thus opposite to that



determined from a predominantly black picture. A carrier oscillator, phase synchronized to the average carrier phase of the signal would execute  $180^\circ$  phase reversals as picture content changed from average white to average black, producing sudden video polarity reversals at the demodulator output.

This signal carrier polarity ambiguity which is momentary in character can be exchanged for one which is not time variable by a multiplication operation. The modulated signal is squared, i.e., multiplied by itself on an instantaneous basis, in a square law circuit. Such an operation squares carrier amplitude and doubles carrier frequency and phase angle, the latter effect converting  $180$  degree phase reversals into  $360$  degree changes which are indeterminable in the average phase detector. Under these conditions the phase synchronized demodulator carrier supply, stably locked to the average phase of the squared signal, experiences no phase reversals with change in picture content. The ambiguity now is in the determination of incoming signal polarity. The squaring operation eliminates any basis for determining polarity so that the demodulator carrier may with equal likelihood lock to either polarity relative to the signal and thereby at the demodulator output produce video signal waveforms of either polarity.

The method used to secure phase synchronization of the local receiver oscillator to the received signal is described next with reference to Fig. 7. Signal from the line together with the output from the carrier oscillator are brought to the demodulator where the desired video output signal is obtained as the lower sideband of the modulation product. This process has already been described, equations 1 to 3. In the carrier regeneration process signal and carrier phase shifted by  $45$  degrees (equations 4 & 5) are each squared in square law circuits.

$$V(t) = P \text{Cos } ct + Q \text{Sin } ct, \quad (4)$$

$$C(t) \angle 45^\circ = \pm \text{Cos } (ct - \phi - \pi/4). \quad (5)$$

Band pass filters select from the squaring circuit output signal frequencies in the neighborhood of twice carrier frequency. From the signal squarer,

$$\frac{1}{2}(P^2 - Q^2) \text{Cos } 2ct + P Q \text{Sin } 2ct \quad (6)$$

and from the carrier squarer,

$$\frac{1}{2} \text{Sin } (2ct - 2\phi). \quad (7)$$

The two squared signals at twice carrier frequency are multiplied together in a product modulator. This product contains signals in two



bands of frequencies, one band in the region of four times carrier frequency and the other in the video frequency band starting at zero frequency. The lower frequency component of this product is selected by a low pass filter following the product modulator yielding,

$$\frac{(P^2 - Q^2)}{2} \sin 2\phi + PQ \cos 2\phi. \quad (8)$$

The dc component of the low pass filter output is a suitable control voltage for synchronization and is obtained in the limit as the cut-off frequency of the low pass filter is lowered. Average values as produced by the low pass filters are applied as a frequency control voltage to the carrier oscillator.

The first term in equation (8)

$$\frac{(P^2 - Q^2)}{2} \sin 2\phi$$

when averaged is, for small errors in carrier phase angle, proportional to the error angle  $\phi$ . The factor of proportionality is recognized as the difference in mean squared values of the "real" and quadrature modulating functions, P and Q, illustrated typically in Fig. 5. This difference is always positive when the modulating signal contains energy components

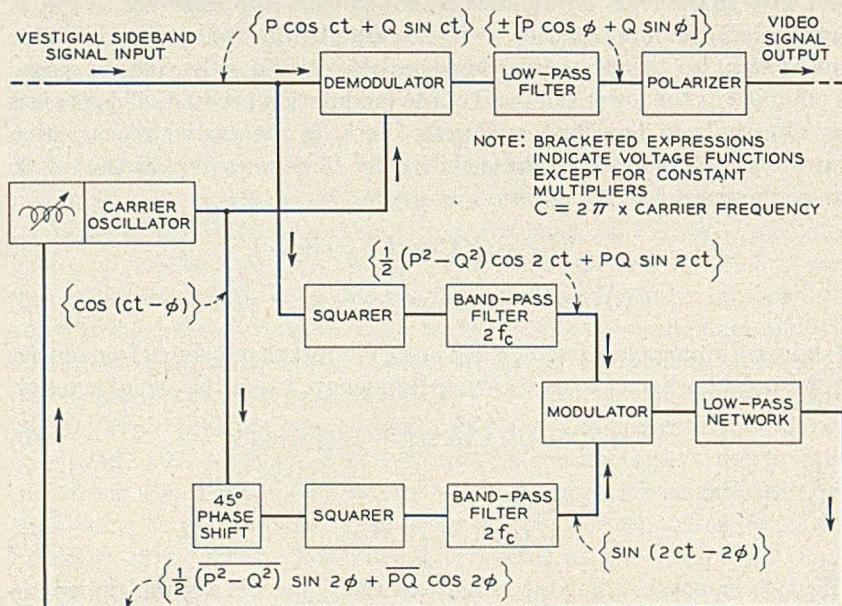

Fig. 7 — Functional diagram of the L3 homodyne demodulation process.



within the bounds of the vestigial sideband since the quadrature response function, Fig. 5(c), is attenuated relative to the "real" response function in this band. In the present case, with a 500 kilocycle vestigial bandwidth and a composite video waveform for a modulating function, the amplitude of  $Q^2$  for control purposes is negligible compared with  $P^2$ .

The second term of equation (8),  $PQ \text{ Cos } 2\phi$ , contains no dc component since  $Q$  itself contains no dc component and all other frequency components of  $Q$  are shifted  $90^\circ$  in phase relative to corresponding components in  $P$ . The dc control voltage therefore is not modified by the existence of the second term of equation (8). However, the function  $PQ$  does contain sum and difference frequencies due to the cross products of the spectra of  $P$  and  $Q$ . These frequencies in the control voltage tend to be large compared with corresponding frequencies due to the products  $P^2$  and  $Q^2$  since the trigonometric multiplier  $\text{Cos } 2\phi$ , equation (8), is large when the phase angle error is small. The effect of the term  $PQ \text{ Cos } 2\phi$  is that of phase modulation of the receiver carrier supply and its suppression determines the characteristics required of the low pass filter which averages the control signal. At the penalty of sluggish synchronization and restricted oscillator pull-in range the phase modulation can be reduced to arbitrarily small values. For our purposes a pull-in range of  $\pm 20$  cps can be achieved with phase modulation less than  $\pm 0.1$  degree with adequate margins.

The control voltage is applied to a tuning element in the receiver oscillator, in this case a small saturable reactor made with ferrite as a core material. This reactor is part of the series resonant quartz crystal circuit which determines the oscillator frequency and is capable of shifting the frequency in response to the control voltage by  $\pm 20$  cps, a figure chosen as safely less than the first sideband components of the transmitted signal which are  $\pm 30$  cycles from carrier frequency. This precaution avoids possible synchronization of the local oscillator to a signal sideband frequency rather than to the carrier.

Sufficient gain is provided in the carrier frequency control loop just described so that the maximum frequency difference encountered between transmitting and receiving oscillators is corrected by the phase control voltage due to a steady state phase angle error,  $\phi$ , less than  $1/2$  degree. The control characteristic of the saturable reactor may be expressed,

$$\Delta f = A(P^2 - Q^2) \text{ Sin } 2\phi, \quad (9)$$

where  $\Delta f$  is the frequency shift introduced by the reactor and  $A$  is the factor proportional to required loop gain.

One other factor to be considered is the stability criterion of the



frequency control circuit as a feedback loop.<sup>7</sup> In this case two factors contribute to loop phase shift. First, the phase angle variation of the oscillator output in response to the control voltage is an integration process. The control voltage changes the oscillator frequency and the resulting phase change can be expressed as the integral with respect to time of the frequency shift,

$$\text{phase, } \theta, = 2\pi \int \Delta f dt. \quad (10)$$

The integration with respect to time introduces a 90 degree "low-pass" phase shift into the control loop at all frequencies. Second, the averaging low-pass filter introduces phase shift in the same direction so that care must be exercised to avoid instability. In this case a phase stability margin of 45 degrees is provided over a wide range of frequency by designing the low-pass filter as a series of resistance capacitance steps of loss. These are staggered in frequency to produce a cut-off rate of 3 db per octave with a phase shift of 45 degrees over a wide frequency band.

The polarity ambiguity resulting from the squaring process has been demonstrated in the derivation of the phase control voltage. In equation (5) the plus or minus designation indicates that either polarity of carrier signal might be assumed without affecting subsequent expressions. However, in the derivation of the output voltage from the main signal demodulation, equation (3), the output signal polarity reverses if the carrier, equation (2), is assumed with reversed polarity. The carrier polarity established at any given time depends largely upon initial phase conditions when signal is applied.

Correct video polarity at the receiver output is established by a new device called a polarizer which follows the demodulator. This circuit recognized video polarity on the basis of standard features in the composite television waveform. The particular features used in this case are the vertical blanking discontinuities expected once each sixtieth of a second and the duty factor of sync pulses. These two characteristics taken together form a sufficient condition for the determination of polarity of any composite video waveform independent of picture content. The polarity, once recognized to be inverted, is corrected.

#### HARMONIC DISTORTION

A significant consideration in transmission problems is the generation of distortion by the non-linear amplitude characteristic of the transmission apparatus. In the case of video transmission, non-linearity results



in the distortion of brightness values of the transmitted picture and presumably will distort chromaticity values of color television signals. With carrier transmission apparatus, in addition to these effects non-linearity produces extraneous interference patterns at harmonics of the carrier frequency. In L3 with a carrier modulated spectrum concentrated near 4.139 mc., the second harmonic distortion of line repeating amplifiers produces a new spectrum concentrated near 8.278 mc, which is demodulated by the receiving terminal to the region near 4.139 mc. This form of distortion is considerably more disturbing in the final picture than a comparable distortion of brightness values and constitutes a limit to transmission signal-to-noise performance.

Advantage is taken of the spectral distribution of energy of television signals to ameliorate somewhat the effects of second harmonic distortion. A pre-emphasis network is employed in the transmitting terminal to accentuate the amplitude of high frequency components of the signal before transmission. At the receiver a restorer network introduces a complementary frequency characteristic to make the overall transmission characteristic constant with frequency, (see Fig. 8). The restorer network, de-emphasizing the high frequency components, likewise suppresses the second harmonic distortion signals. A limit to the amount of predistortion permitted is set by the maximum amplitudes expected of the high frequency picture components particularly in anticipation of a high frequency color sub-carrier in color television systems. Tentatively, the characteristic of Fig. 8 is chosen as a compromise of these factors.

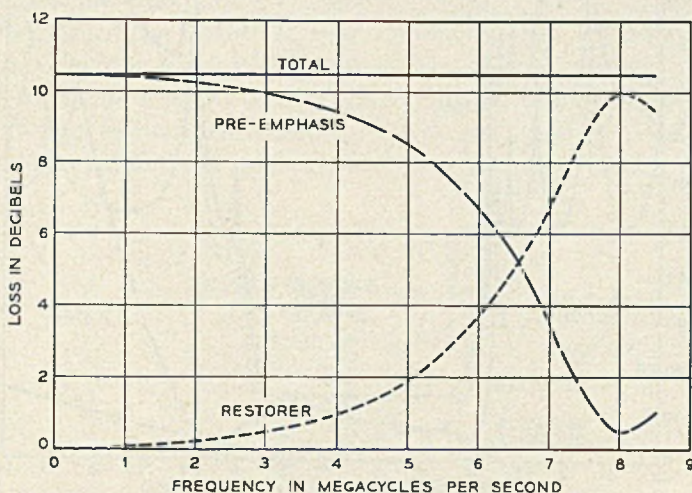

Fig. 8 — High frequency pre-emphasis characteristic.



## FILTERS AND EQUALIZERS

A low-pass filter is required before the video signal is modulated, to limit the bandwidth of the signal, eliminating possible sources of disturbing cross products, both in the modulator and in the repeaters of the L3 system. This filter has a cut-off at 4.3 mc and provides over 40 db discrimination to all frequencies greater than 4.8 mc. It consists of three m-derived sections and introduces about 1.3 microseconds of envelope delay distortion near its cut-off frequency. This is equalized after modulation by the delay equalizer to be described later.

Following the modulator is the vestigial sideband filter which passes the upper sideband, and provides 60 db discrimination against all frequencies in the lower sideband less than 3.7 mc. The large discrimination is required to avoid interference with the telephone channels during transmission over the coaxial line. This filter provides a controlled loss characteristic to frequencies in the band 3.64 to 4.64 mc which satisfies the requirement for vestigial sideband transmission. The response function for this band is shown on Fig. 2. A flat transmission characteristic including the effective pass band loss of the video LP filter is maintained over the entire upper sideband from 4.6 to 8.44 mc. A second low pass filter after the modulator provides at least 50 db discrimination against third and higher harmonics of the TV carrier (4.139 mc).

A four section high-pass filter designed by the insertion loss method<sup>8</sup> is used to supply 50 db of the discrimination at frequencies less than

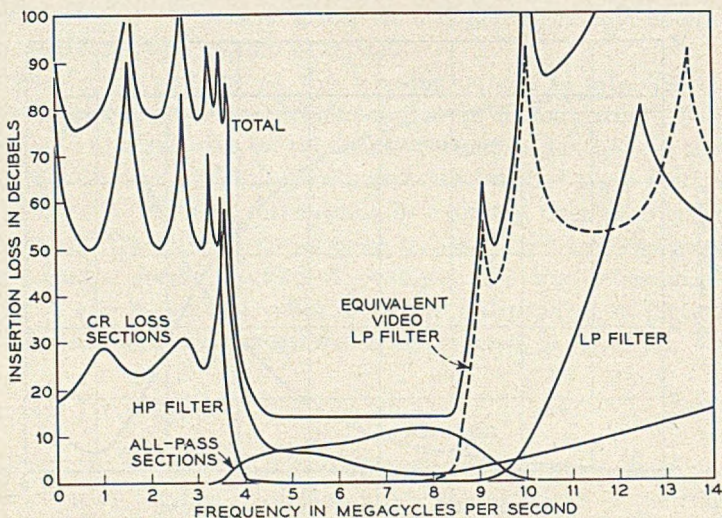

Fig. 9 — Insertion loss of the transmitting terminal filters.



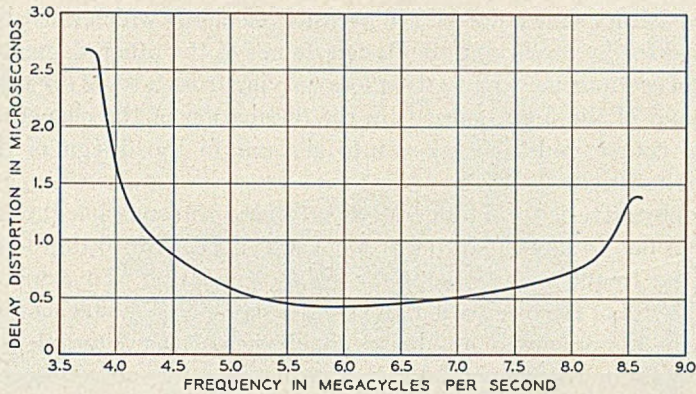

Fig. 10 — Envelope delay distortion of the transmitting terminal filters.

3.5 mc. This filter has a low-pass shunt network at the input to maintain its stopband impedance at 75 ohms. This is required because to produce a uniform frequency characteristic the impedance facing the modulator has to provide a reflection coefficient not exceeding 3 per cent. The remaining discrimination at frequencies less than 3.7 mc and the major part of the vestigial sideband shaping are provided by a group of six constant resistance equalizer sections, as shown on Fig. 9. The low-pass filter to suppress carrier harmonics consists of 2 m-derived filter sections.

The delay distortion of the complete set of filters and loss equalizer sections is shown on Fig. 10. This includes the equivalent delay distortion of the video low-pass filter, translated in frequency for equalization after the modulator. The distortion must be equalized to a constant delay over the television band. A delay equalizer to do this is incorporated in the filter. It was designed by a potential analogue method<sup>9</sup> and consists of 24 all-pass sections, each having the schematic as shown in Fig. 11. A redundant capacitor is used to avoid excessively small capacity values.

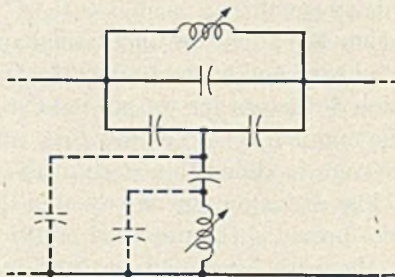

Fig. 11 — Schematic of a delay equalizer section, (dotted capacitors are parasitic).



The capacitors shown dotted are parasitic elements which must be compensated for by modifying the design values of the other elements. This group of sections has an insertion loss varying from 2 to 12 db across the pass band of the filter, caused by the dissipation of the elements. This loss, of course, must be taken into account in the design of the loss equalizer sections.

The objective is to obtain equivalent video transmission through the terminal flat to limits varying from  $\pm 0.02$  db to  $\pm 0.10$  db, depending upon the frequency characteristic of the deviation. To achieve this, close control of the dissipation loss is essential. The inductor losses which cause the major part of the delay equalizer loss characteristic vary up to  $\pm 15$  per cent from nominal values. As a means for controlling inductor  $Q$  to  $\pm 0.5$  per cent or better, a "Q adjusting screw" is employed. The inductors are solenoids wound on molded tubes with a threaded hole through the center. A threaded magnetic dust core is used for inductance adjustment. Its travel can be limited to the distance from the center to one end of the form without losing adjustment range. By introducing an additional core made of solid magnetic iron into the field of the solenoid, using the opposite end of the form, an adjustment is provided which reduces the  $Q$  in a continuous manner as the second screw is advanced into the form. The reduction in  $Q$  is caused by the losses in the iron, and normally these would cause a reduction in inductance also. However, the permeability of iron causes an increased concentration of field which tends to increase the inductance. A balance between these tendencies to decrease and to increase the inductance is obtained by controlling the geometry of the  $Q$  adjusting core. As a result, a reduction of up to 50 per cent in  $Q$  can be obtained, accompanied by a change of less than one per cent in the inductance. Models of the inductor and the adjusting screws are shown on Fig. 12. This adjusting screw in conjunction with the magnetic dust core provides an accurate and economical means for adjusting simultaneously both inductance and dissipation in each inductor of the delay equalizer.

The flat transmission level for the upper sideband and the shaped cut-off for the vestigial sideband were obtained by including loss equalizer sections, assuming  $Q$  factors for the all-pass sections of about 20 per cent less than the nominal  $Q$  of the inductors. As a final step in the design, the  $Q$  factors were modified to absorb in the loss of the all-pass sections the residual loss distortion uncompensated by the loss equalizer sections. This in effect provided the use of 24 additional parameters for shaping the loss in the pass band and resulted in an improved loss characteristic.



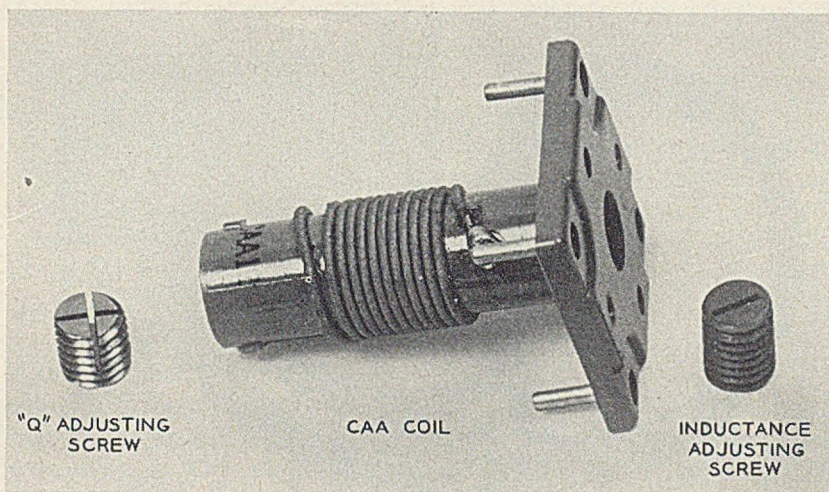

Fig. 12 — Inductor with adjusting screws.

The close limits on delay distortion can be met only by close control of the adjustments on the individual all-pass sections. In order to obtain reproducible results to the order of  $\pm 0.1^\circ$  for the phase shift and  $\pm 0.01$  db for the insertion loss of the individual sections, a special fixture is employed to make the connection between the section and the measuring circuit. This is shown in Fig. 13. The fixture can be clamped on the network terminals quickly without soldering and provides coaxial patch cords with plugs for connection to the measuring circuit. Each section is mounted in an individual container with shielding between the inductors to reduce coupling. Each inductor is resonated with its associated capacitors and the dissipation is adjusted by adjusting the two cores. The construction of a typical section is illustrated by Fig. 14.

An important consideration in obtaining smooth loss and delay characteristics for the delay equalizer is the reflection coefficient of each section. Poor reflection coefficients cause reflections and interactions between all-pass sections. Due to the large phase slope of the equalizer these tend to produce frequency characteristics with large numbers of loss and delay ripples across the frequency band for which transmission requirements are most severe. Reflection coefficients of 2 per cent or less at all frequencies in the TV band have been obtained for all delay sections by taking the following precautions:

1. Mutual coupling is limited between the two inductors in each section by use of a shield in the section container. As little as 0.1 per cent



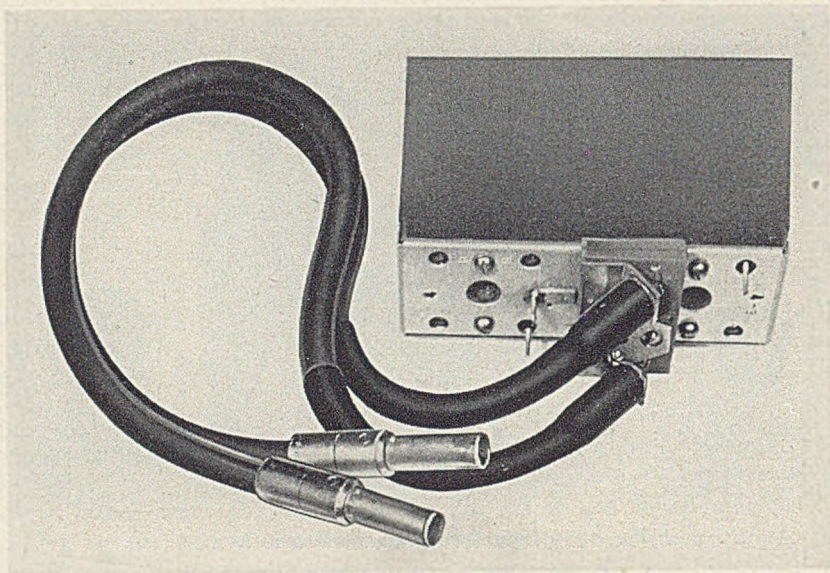

Fig. 13 — Fixture for delay equalizer section adjustment.

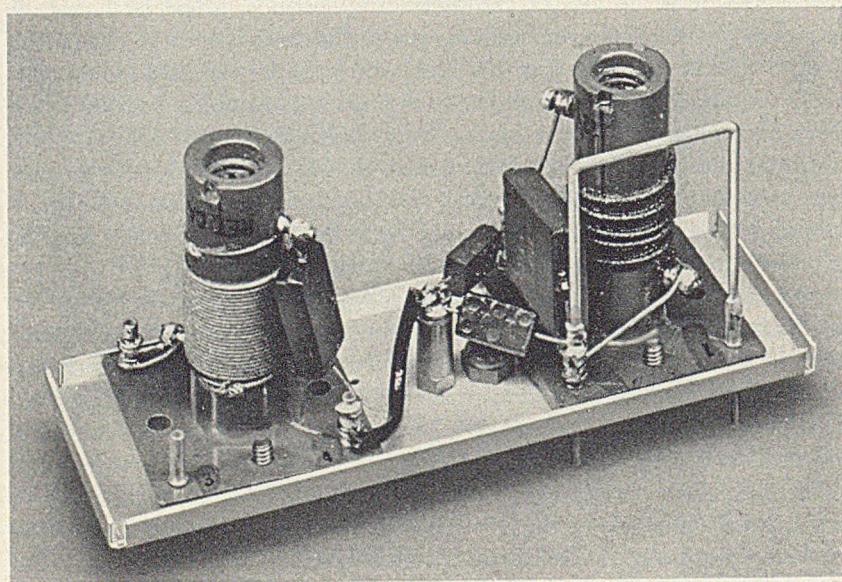

Fig. 14 — Model of a typical delay equalizer section.



coupling coefficient can cause a reflection coefficient of 1 per cent in certain sections at the frequency of  $180^\circ$  phase shift.

2. The  $Q$  factors of both inductors are adjusted to be equal in each section.

3. The values of the capacitors are modified to compensate for the presence of the parasitic capacitances associated with the shunt arm, Fig. 11.

The measured insertion loss characteristic and phase shift deviation from linear phase slope for one model of the transmitting filter and delay equalizer is shown on Fig. 15. This has been reduced to video frequency to show the detailed residual distortion which results from the addition of the vestigial lower and upper sideband. The delay equalization is maintained for about 200 kc above the loss cut-off to provide for at least 30-db insertion loss at frequencies where the delay distortion becomes large. Without this precaution the transient response is characterized by a severe "cut-off ring" distortion which is a slowly damped oscillation at cut-off frequency generated by high frequency signal components.

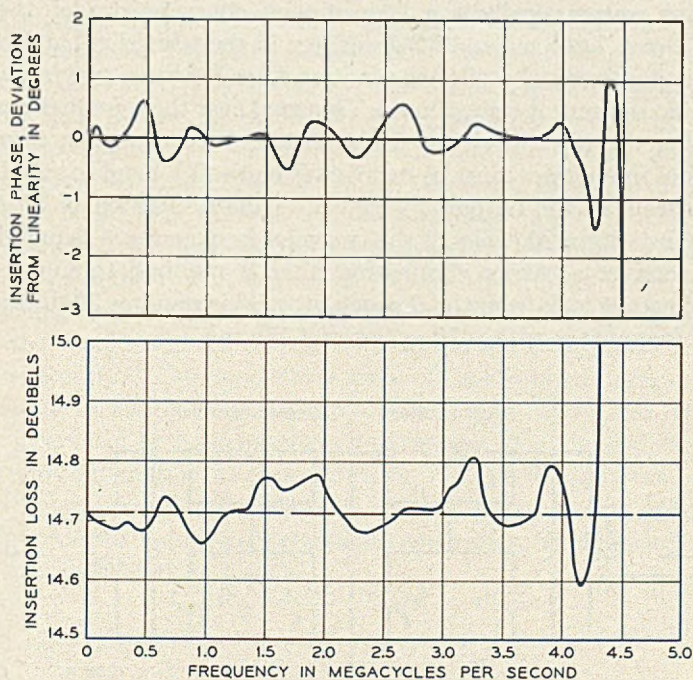

Fig. 15 — Measured pass band performance of a trial model of the transmitting filters and equalizer.



Variations in transmission response in the region near television carrier cause noticeable "smear" distortion on the received images. These variations can be introduced by small changes in element values of the filter or equalizer sections following initial adjustment, or by other changes in both transmitter and receiver. As a means of compensating for such variations, two adjustable loss equalizers have been provided, each with adjustable maximum loss at carrier frequency. One has a half-loss point at 300 kc and the other at 80 kc from the carrier. These are adjusted for minimum "smear" at periodic intervals.

A fixed equalizer is provided in each terminal to compensate for loss and delay distortion other than that in the filters described above. For convenience, this equalization is done at modulated frequencies. It is expected that additional means for periodic re-equalization of the terminal gain and phase characteristics will be necessary to achieve 4,000 mile, tandem terminal transmission quality objectives.

#### PILOT FREQUENCIES FILTERS

As described elsewhere,<sup>1</sup> the L3 system has six pilot frequencies for regulating automatically the transmission characteristic of the line. Two of these, 7.266 mc and 8.320 mc, are in the television band. At the transmitting terminal a pilot elimination filter for these two frequencies is required to prevent energy in the TV signal near these frequencies from disturbing the pilot levels on the system. At the receiving terminals, these pilot frequencies must be removed from the TV band to avoid interfering effects in the output TV signal. A discrimination of 50 db for frequencies within 20 cycles of the two pilot frequencies is required. Also at the receiver a carrier elimination filter is required to suppress the residual carrier leak from the demodulator. This requires 30 db suppression to frequencies within 20 cycles of 4.139 mc.

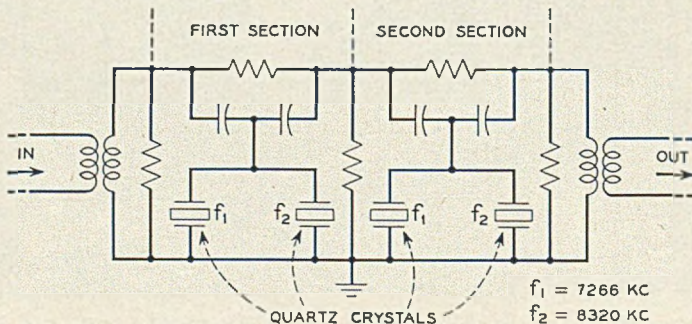

Fig. 16 — Simplified schematic of the pilot frequency band elimination filter.



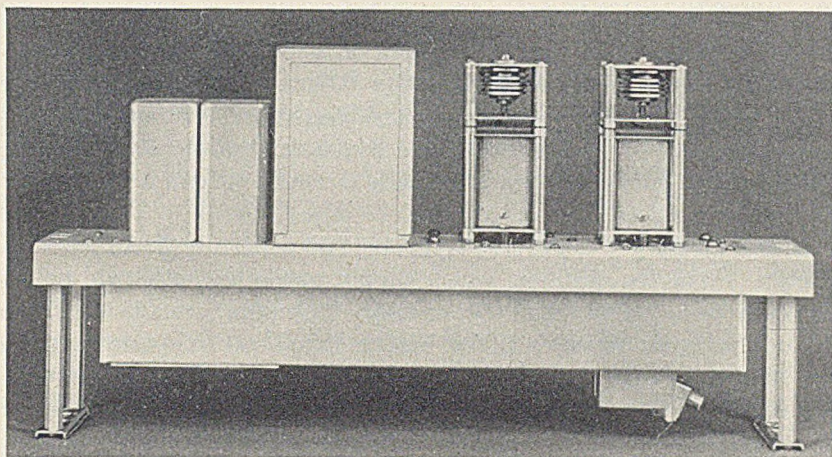

Fig. 17 — Model of the carrier suppression filter.

To avoid removing excessively broad bands of frequencies from the television band, and thereby generating visible distortion in the transmitted picture, narrow bandwidth crystal filters are used for both of these applications. The pilot elimination filter has its 3 db loss points at about 1,000 cycles on either side of the pilots. The carrier suppression filter has its 3 db loss points at 150 cycles on either side of the carrier. In the past, spurious or secondary responses in the crystal units could not be limited to sufficiently low values to permit available crystals to be used in broad band circuits without elaborate means for suppressing the unwanted responses. In the L1 system, for example, a balancing circuit using hybrid coils was employed for this function. Techniques for reducing unwanted responses in the crystal units by special contouring of the blanks and by precise optimum area plating have been developed recently.<sup>10</sup> The use of these methods has resulted in crystal units in which the unwanted responses are reduced to the extent that relatively simple filters can be used for these applications. A simplified schematic of the pilot elimination filter is shown on Fig. 16. Small ovens are provided to maintain close temperature control for the quartz crystal elements in order to stabilize the resonant frequencies. Mechanical arrangements are illustrated on Fig. 17.

#### POWER EQUIPMENT

Primary power for the television terminals is 60-cycle ac. It is derived from the L3 motor-alternator power equipment at main repeater sta-



tions or, alternatively, from commercial 60-cycle sources. When commercial power is used directly a provision is made for switch-over to emergency power in the event of power failure. The emergency power supply comprises a 130-volt battery, an inverter, and automatic switch-over equipment. If during service the commercial power source fails a switch-over to emergency power is made automatically in a time under one-tenth second.

Dc and heater power provisions involve two departures from previous practice. First, the rectifiers which supply anode and other dc power requirements are non-regulated metallic, (selenium), rectifiers. These are supplied from magnetic ac line voltage regulators to obtain suppression of line voltage variations. The combination of the magnetic ac regulator and the metallic rectifier provides adequate suppression of hum and line voltage variations with, it is expected, greater reliability than alternative vacuum tube regulated rectifiers. Secondly, the magnetic ac line voltage regulator together with an improved heater transformer design make possible the operation of the vacuum tubes at reduced heater voltage to obtain increased thermionic life expectancy. This advantage can be taken only if close control of heater transformer output voltage is possible. In this case, variations in output voltage expected to occur due to temperature variations of the transformer windings substantially have been eliminated by incorporating thermistor temperature compensation in the transformer primary circuit.

### T3 TRANSMITTING TERMINAL

A block diagram of the components of the transmitting terminal is shown in Fig. 18. The composite video signal is received from the Bell System television operation center over 124-ohm balanced cable and

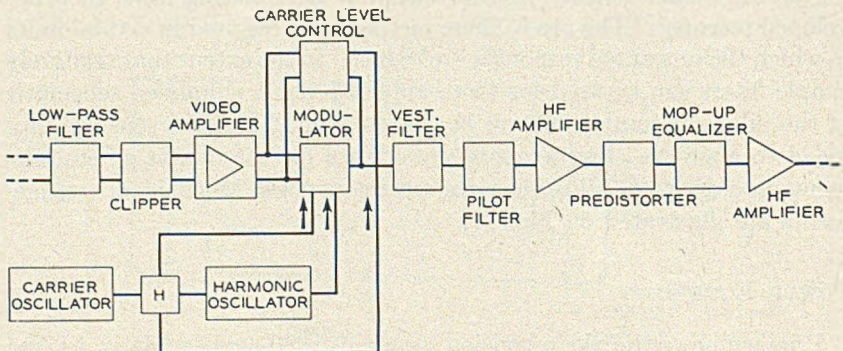

Fig. 18 — L3 transmitting terminal block diagram.



the modulated output signal is delivered to the L3 line facilities over 75-ohm coaxial cable.

An input low-pass filter and a video clipper circuit place ceilings on the maximum transmitted signal bandwidth and signal amplitude, respectively. The clipper circuit is required to protect the 600 telephone channels from inadvertant overloads due to excessive television signals. Normal amplitude signals are not affected by the clipper.

Following are a video amplifier and the modulator together with the required carrier supplies and the carrier level control. This latter device accurately regulates the peak carrier magnitude in the output signal and thereby preserves the desirable maximum modulation.

Following the modulator is the vestigial band filter which, together with its delay equalizer, shapes the double sideband modulator output into the vestigial transmission band. The flat loss of these networks requires that amplification be provided in the carrier frequency band to increase the signal level. The first of two high frequency flat gain amplifiers in the transmitter restores the signal amplitude.

The pilot band elimination filter is next provided to remove television signal energy and other possible interference from particular frequencies allocated to the L3 line pilot signals.

At this point occur the predistorer network for pre-emphasizing the high frequency signal components and a mop-up equalizer. The mop-up equalizer is to provide means for periodic correcting of the transmission characteristic. The high-frequency amplifiers, particularly, change their transmission characteristic as the vacuum tubes age. An additional high frequency amplifier is provided to recover the loss of the foregoing networks and deliver a proper signal level to the line equipment.

### R3 RECEIVING TERMINAL

The receiver demodulates the signal as transmitted over the L3 line facilities to recover the video signal for transmission over local video circuits. As has been discussed the demodulation is a homodyne process utilizing a local carrier regenerated from information contained in the transmitted signal.

A block diagram of receiver components is shown in Fig. 19. The first components are a group of networks; the restorer to compensate for transmitter predistortion, the fixed and variable mop-up equalizers to compensate for deviations in the receiver frequency characteristic, and a pilot elimination filter to remove L3 pilot frequencies from the signal. A high frequency amplifier provides amplification to compensate for the network losses.



The amplified signal is split into two branches by a hybrid transformer. Part of the signal is carried to the demodulator for detection to video frequencies while the remainder is employed in the carrier regeneration apparatus. The carrier supply oscillator output likewise is split between the same two circuits; the portion supplied to the demodulator providing the carrier energy for demodulation and the part sent to the carrier regeneration circuits providing means for comparison with the input signal. The carrier regeneration equipment comprises mainly the phase comparison circuit together with means for changing electronically the frequency of the carrier supply oscillator.

The phase synchronized carrier supply together with the associated third harmonic supply provide demodulating carriers which translate the carrier spectrum down in frequency to the original video spectrum. The demodulator output also contains an unwanted upper sideband in the 8 to 12-mc region. This signal and residual carrier leak from the demodulator are removed from the detected signal by a low-pass filter and the quartz crystal narrow band rejection filter tuned at carrier frequency. Finally the signal is amplified at video frequencies to provide moderately high video frequency transmission levels and transmitted through the reversing relays of the polarizer to the receiver output.

Fig. 20 is a photograph of two equipment bays each eleven feet high which comprise at the left the T3 transmitting terminal and at the right the R3 receiving terminal.

Acknowledgement is made for the many contributions made by our associates toward the successful development of these terminals. These include both ideas related to transmission processes and important contributions in the development of many new circuit components which were necessary to the achievement of the quality and reliability objectives.

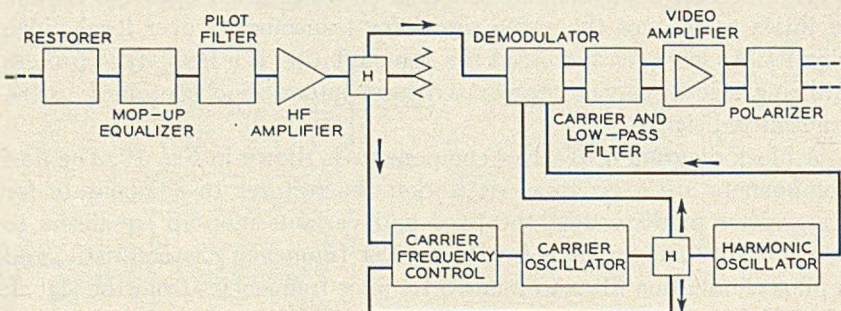

Fig. 19 — L3 receiving terminal block diagram.



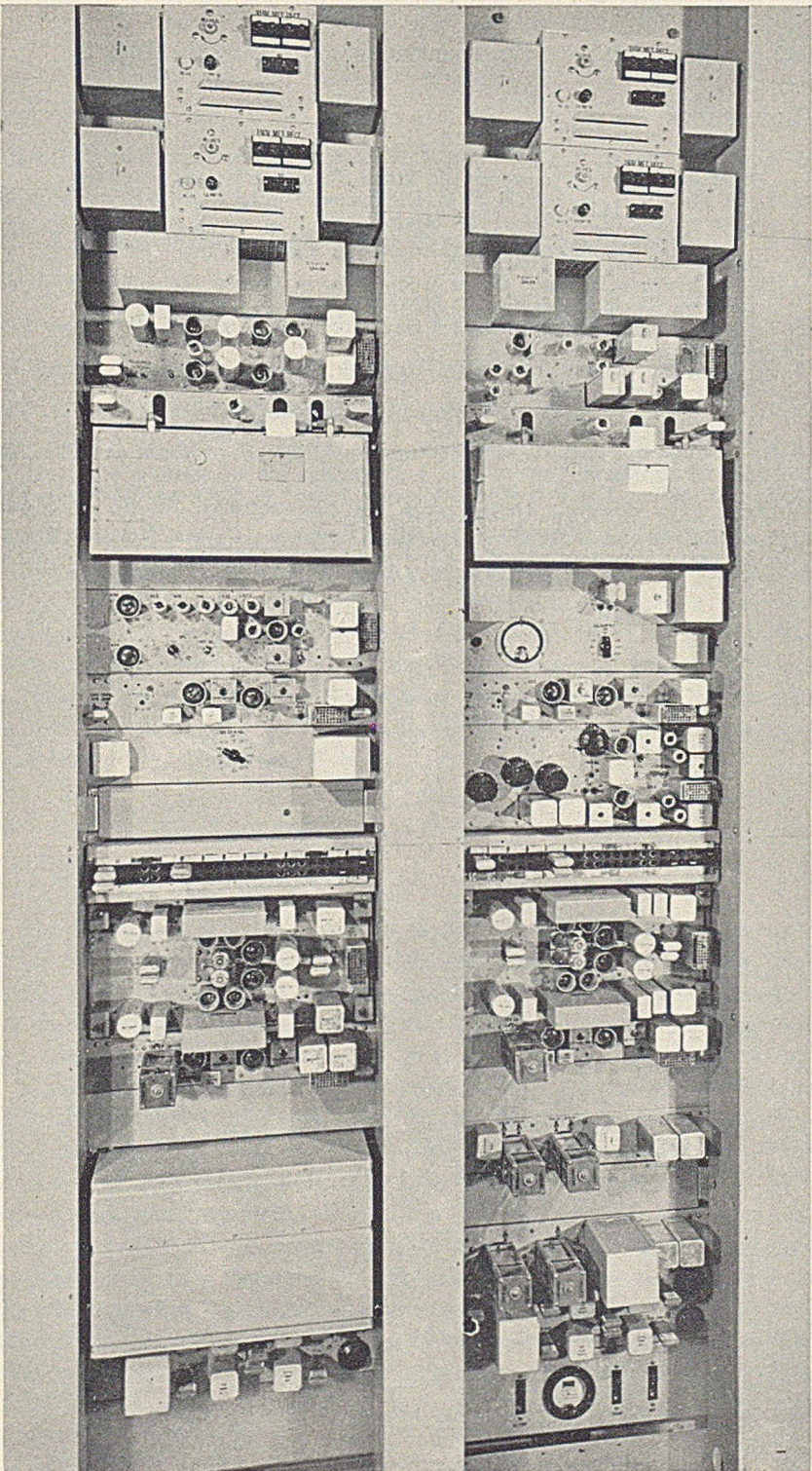

Fig. 20 — Model of transmitting and receiving terminal equipments.



## REFERENCES

1. C. H. Elmendorf, R. D. Ehrbar, R. H. Klic, A. J. Grossman, The L3 Coaxial System—System Design, see pp. 781 to 832 of this issue.
2. L. H. Morris, G. H. Lovell, F. R. Dickinson, The L3 Coaxial System-Amplifiers, see pp. 879 to 914 of this issue.
3. L. W. Morrison, Jr., Television Terminals for Coaxial Systems, A.I.E.E., Trans. **68**, pp. 1193-1199, 1949.
4. R. S. Caruthers, Copper Oxide Modulators in Carrier Telephone Systems, Bell Sys. Tech. J., **18**, pp. 315-337, April, 1939.
5. L. A. Meacham, Bridge-Stabilized Oscillator, Bell Sys. Tech. J., **17**, pp. 574-591, Oct., 1938.
6. H. Nyquist, Certain Topics in Telegraph Transmission Theory, A.I.E.E., Trans. **47**, pp. 617-644, 1928.
7. H. W. Bode, Network Analysis and Feedback Amplifier Design, D. Van Nostrand Co., 1945.
8. S. Darlington, Synthesis of Reactance Four-Poles, J. of Math. and Phy., **18**, pp. 257-353, Sept. 1939.
9. S. Darlington, The Potential Analogue Method of Network Synthesis, Bell Sys. Tech. J., **30**, pp. 315-365, April, 1951.
10. L. J. LaBrie and D. F. Ciccolella, High Frequency Crystal Units for Use in Selective Networks, submitted for publication, I.R.E. Trans. (Presented at I.R.E. subcommittee meeting, Washington, D. C., Dec. 4, 1952).



# The L3 Coaxial System

## Quality Control Requirements

By H. F. DODGE, B. J. KINSBURG and M. K. KRUGER

(Manuscript received May 5, 1953)

*Economic solution of the equalization problem in the L3 system required limitation of the excursions of the transmission characteristics from the design center. To implement this, a pattern of distribution requirements for component elements of the system was worked out utilizing basic quality control techniques. An analysis of the several methods employed is presented with particular emphasis on the intent of the choices which were made and the operating characteristics of the resulting procedures. One of the novel features is the three-cell selection method which insures that the product delivered has the kind of distribution that is wanted even while the process is in trouble distribution-wise.*

### 1.0 REASON FOR REQUIREMENTS

#### 1.1 EQUALIZATION PROBLEMS

The L3 system is a long distance carrier system designed to transmit either 1,860 telephone channels or 600 telephone channels plus one television channel. The band width is approximately 8 mc. The repeaters are spaced about 4 miles apart and in a 4,000-mile route, counting both line and office amplifiers there will be about 1,200 amplifiers in tandem.

There are two equalization problems. The first is equalization proper, i.e., delivery of a satisfactory signal to the customer from the transmission characteristic point of view. The television equalization design objective of the system is to meet a signal-to-echo ratio of 40 db. This corresponds to a uniform sinusoidal ripple of 1/10 db or a complex deviation pattern several times larger in amplitude. The telephone equalization objective is more lenient and allows deviations as large as 1 to 2.5 db, depending on length of circuit and number of links in tandem. Though care was exercised to make basic design decisions which would tend to ease the equalization problem, still the reduction of the accumu-



lated deviation arising in 1,200 amplifiers to a few tenths of a db is a formidable problem.

The second problem is concerned with the effect of equalization on the signal-to-noise performance. As deviations creep into a repeatered circuit, the transmission levels deviate more and more from the normal or design levels. This effect is lumped in one term, misalignment. The result of misalignment is degradation in signal-to-noise performance. Periodic equalization helps to limit misalignment in the succeeding repeater sections but does not eliminate the increase in noise or modulation which has occurred in the preceding repeaters. Thus, the objective is not only to equalize the over-all circuit, but also to keep the deviations all along the transmission line within the specified bounds in order not to exceed signal-to-noise margins.

## 1.2 NEED FOR CONTROLLING DEVIATIONS AT THEIR SOURCE

Let us examine what accounts for the magnitude of the gain-versus-frequency deviations arising in any one repeater. Let us assume that a particular element deviates +1 per cent from the design objective. Is this good or bad? The answer to this question may be had only if a deviation study of the repeater is made and its sensitivity to the deviation of the element under consideration is ascertained. There are two factors which contribute to the equalization problem: (a) the deviation sensitivity of the repeater to a given deviation of the element from its prescribed value, and (b) the actual deviation of the element itself due to all causes, including manufacture, temperature, aging, etc. To simplify our terms, factor (a) will be called the sensitivity of the element, and factor (b), the deviation of the element. The sensitivity is a function only of the circuit design and is independent of the performance of the individual element. The deviation of the element is a function only of its design and manufacture.

## 1.3 USE OF STATISTICAL QUALITY CONTROL METHODS TO ASSURE A CONTROLLED DISTRIBUTION

When the design of the L3 system was initiated, it was realized that the effect of the variability of the component elements could be materially reduced by the application of statistical quality control techniques to design and manufacture. Once a circuit design is available and a deviation sensitivity study is made, it is comparatively easy to formulate the desired limits on the variability of components. Actually the process of arriving at an individual tolerance objective is more complex



since there is a large area of give and take between the circuit and the component element designers.

Let us assume that the process of arriving at a satisfactory component element design has been completed and that the spread of the manufacturing limits has been set at  $\pm y$  per cent. How will the gain deviations due to this element grow, as more and more repeaters, each containing one unit of this element, are placed in tandem? It is evident that the cumulative magnitude of gain deviations will depend on the distribution pattern describing the departure of individual units of this element from the prescribed value.

If all units of this element have a systematic deviation (equal in magnitude and sign) from the prescribed value, the cumulative gain deviation will be

$$n\alpha_1 \text{ db}$$

where  $n$  = number of repeaters in tandem, and

$\alpha_1$  = gain deviation in one repeater due to  $y_1$  per cent deviation of the element.

If the units of this element have a Normal distribution whose average coincides with the prescribed value, and whose extreme limits (say 3-sigma limits) are  $\pm y_2$  per cent, then the averages of random groups of elements in  $n$  repeaters will be described by another Normal distribution, the corresponding limits of which will be  $\pm y_2/\sqrt{n}$  per cent. Thus the over-all limits of gain deviation for  $n$  repeaters will be

$$\pm \frac{n\alpha_2}{\sqrt{n}} \text{ db} = \sqrt{n}\alpha_2 \text{ db}$$

If, however, the average of the distribution of individual units does not coincide with the prescribed value but is displaced by  $y_1$  per cent, then the over-all gain deviation limits for  $n$  repeaters in tandem will be

$$(n\alpha_1 \pm \sqrt{n}\alpha_2) \text{ db.}$$

Thus, it is of first importance that the average of the individual units be controlled as closely as possible to the prescribed aimed-at value.

Of course, distributions other than Normal are possible. However, it is sufficient for most practical purposes to consider only the Normal distribution since a combination of a large number of distributions, which individually are not Normal, will tend to approximate a Normal distribution. This assumption is a reasonable one to make because of the large\* number of different elements which are used to make up an L3

\* There are over 100 component elements in the L3 amplifier of which about 12 have large element sensitivities and are therefore critical in evaluating performance. There are over 30 additional elements the sensitivities of which are also sufficiently large to require application of distribution requirements.



repeater. It should be kept in mind that this assumption would not be valid if the contribution of one element to the deviation pattern of the repeater becomes dominant, say, larger than all the other elements combined.

In the L3 system, the first stages of equalization are spaced about 25 repeaters apart. In accordance with the above considerations, a distribution of individual element variations, the average of which is controlled close to the nominal, will result in cumulative gain deviation which will be substantially smaller than if no restrictions were placed on the average. Thus, a desired objective for critical L3 component elements is to provide a stabilized production process giving a distribution of individual values (a) having an *average* that is maintained consistently close to a desired nominal, and (b) having a pattern of variation around the average that is Normal (or nearly so). If this is attained, comparatively wide limits for the individual units are acceptable. Furthermore, assembly of component elements into amplifiers can be made on a random basis, and the problem of maintaining equipment in the face of replacement of parts failing in service will be greatly simplified.

From the very nature of the over-all problem the best approach to this objective has appeared to be through the application of statistical quality control methods, both in the design of and in the production of the component elements that are important from an equalization point of view.

## 2.0 BASIC FEATURES OF DISTRIBUTION REQUIREMENTS

### 2.1 GENERAL PLAN

For each of the important component elements, then, interest centers on closely controlling the collective quality of the product, especially the average of the individual values. This can hardly be accomplished merely by specifying and securing compliance with the usual type of requirements, expressed as maximum and minimum limits for individual units. Something more is needed. Consideration must be given to ways and means of placing requirements on the distribution of individual values from the successive increments of the product turned out day after day.

Accordingly, a general plan using quality control methods has been developed, specific features of which will be discussed in this paper with particular emphasis on the intent of certain choices that were made and on the procedures selected to meet the general objective. Further development work on some of these features may of course be found warranted as experience with them is gained.



The general plan has been implemented by imposing on important component elements certain so-called "distribution requirements" which incorporate quality control procedures for assuring a high degree of statistical uniformity in the quality of product delivered for service. The aim of the distribution requirements is to place a continuing limitation on the pattern and the spread of measured values (of a final critical characteristic of the product) around their average and to impose close limits on the departures of the average from a desired nominal value. To obtain these ends, close cooperation between the element designer and the production engineer is essential. In fact, compatibility of the specification requirements and the process capability is one of the basic provisions of the general plan. This should be established, if at all possible, in the design stage.

In some cases where distribution requirements have been applied to a final characteristic of an element, the production engineer has found it advantageous to introduce quality control techniques in some of the earlier manufacturing steps, as for example, on materials, piece-parts, or process operations which are found to have a major effect on end quality.\* The character of such controls can rarely be planned in advance, but must be tailor-made to fit the particular process being used. Often too, a major difficulty encountered has been not the process itself but the precision and accuracy of the measuring equipment. The resolving of such problems during the design and the early production stages has been one of the aims of the general plan.

## 2.2 SELECTION OF CHARACTERISTICS TO BE CONTROLLED

The general procedure calls for imposing distribution requirements on not more than one characteristic of any component element. Before assigning limits on an individual component, therefore, it is important that the characteristic selected for control be the key characteristic. This statement seems to be trite, but its importance cannot be over-emphasized. Controlling all characteristics of a component is not only inherently uneconomical but may be found impossible in practice. In the case of an inductor, for example, it should be ascertained which characteristic is important to the circuit designer. It may be the value of inductance, of  $Q$ , of temperature coefficient, or of parasitic capacity. In addition, of course, requirements should be specific and apply, for instance, at a given frequency or within a definite temperature range.

\* R. F. Garrett, T. L. Tuffnell and R. A. Waddell, The L3 Coaxial System — Application of Quality Control Requirements in the Manufacture of Components, see pp. 969-1006 of this issue.



Where it is desirable to exercise some control over one or more characteristics in addition to the key characteristic, a procedure is provided which requires that control charts be maintained on the additional characteristics. This procedure does not require a controlled distribution for such characteristics, but it does give a statistical record which shows the dynamic behavior of the process and indicates when remedial action is desirable.

### 2.3 COMPATIBILITY OF SPECIFICATION REQUIREMENTS AND MANUFACTURING PROCESSES

As mentioned above, special effort has been made in the L3 project to provide specification limits and manufacturing processes for individual component elements that are mutually compatible.

In order to determine realistic limits on the value of a particular quality characteristic, it is necessary to collect a reasonable quantity of data from the proposed process to show what it can do if brought into a state of statistical control. This is an area in which close cooperation between the element designer and the production engineer is necessary. Here it is convenient to define the "natural tolerance" of a process as the extreme range of variation to be expected among individual units of product made in relatively short periods of time, such as in single batches or production lots; mathematically it is taken to be equal to  $6\sigma$ , where  $\sigma$  is the basic standard deviation of the process as estimated from the average spread for a *series* of samples, each selected from a different segment of production.

If it is found, for instance, that the natural tolerance of the process ( $6\sigma$ ) is wider than the expected or desired specified limits, then a fundamental change either of the process or of the basic design of the component or both is called for, if mutual compatibility is to be attained. Of course, one way to avoid a major change would be to widen the specification limits. If the needs of the system, however, demand the closer limits, such a simple solution is not possible, and a manufacturing process or design change must be made. In many cases examined in connection with the L3 repeater, the economics of the situation — balancing the component cost against the saving in equalization gear — justified additional effort to improve designs and manufacturing processes to obtain limits for individual component elements narrower than those which initial processes appeared capable of meeting.

### 2.4 THE PROBLEM OF MEASUREMENT

The precision of measurement may have an important influence on the determination of the process capability. Let us assume that the



universe of true values for an element may be described by Curve A in Fig. 1, having a spread of  $2r$ . Let us also assume the distribution of errors of measurement representing the precision of the measuring device (assumed to be unbiased) is described by Curve B of Fig. 1, having a spread of  $2s$ . If, for the purposes of discussion, these distributions are Normal, the resulting apparent distribution of the individual values (the distribution of measured values) is a composite of the distribution A and B, as shown by Curve C of Fig. 1. The spread of this distribution will be  $2q$ , where  $q = \sqrt{r^2 + s^2}$ . If  $s = \frac{1}{2}r$ , as shown in Fig. 1, then  $q = \sqrt{r^2 + 0.25r^2}$  or  $q = 1.118r$ . Thus, the apparent distribution has a spread which is about 12 per cent greater than the true distribution. Similar computations for other values of measuring precision in relation to the true distribution give the following:

Ratio $s/r$	Ratio $q/r$
1	1.414
0.5	1.118
0.2	1.020
0.1	1.005

Measurements normally made to determine process capabilities include the effect of random errors but not necessarily of systematic errors.

The effect of systematic error or bias of the measurements is quite different. Bias tends to cause unknown and unwanted displacement of the process average from the aimed-at value. This, in turn, can be re-

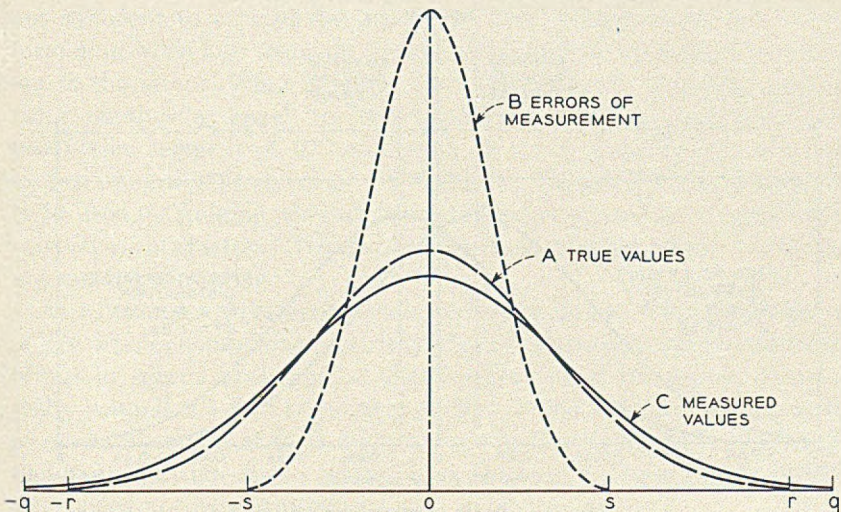

Fig. 1 — Effect of measuring errors.



responsible for systematic deviations which are so undesirable in the L3 system. One way to combat or, rather, circumvent large bias is to rely on comparison standards in the calibration of test sets. The task of furnishing and maintaining reliable comparison standards has many pitfalls. It is an art or perhaps a science in itself and is mentioned here only because of its importance to the objective of restricting variations in the process average.

Considering the effect of both random and systematic errors of measurement, it has been found essential to place comparatively tight requirements on the accuracy of the test methods to be used. In many instances meeting these accuracy requirements was made possible by the development of new or radically improved measuring equipment for both laboratory and production purposes.

## 2.5 ALLOWABLE MARGIN FOR DRIFT OF PROCESS AVERAGE

Having determined  $\sigma$ , the basic standard deviation of an acceptable process for a quality characteristic, then the minimum spread of specified limits, to be compatible with the process, would be  $\pm 3\sigma$  around the nominal ( $N$ ). However, product having this  $\sigma$  could be expected to meet such limits practically all the time provided only that the average of the process were controlled at the nominal. Accordingly, provision was made to allow the process average itself to vary within a band of  $\pm \frac{1}{3}\sigma$  around the nominal. This allowance is somewhat arbitrary and represents an estimate of relative importance to the L3 system of systematic changes

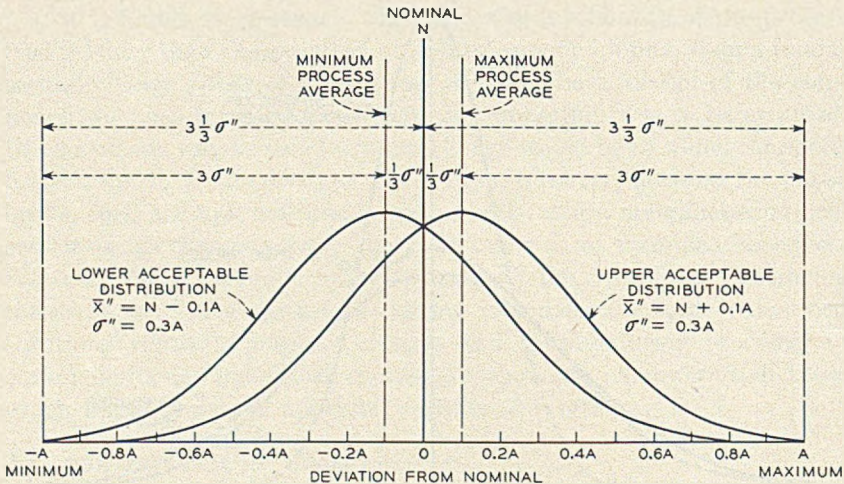

Fig. 2 — Basis of specified limits.



in the process average. Thus, two limiting acceptable distributions, Normal in shape, are defined as indicated in Fig. 2, both having a standard deviation,  $\sigma''$ , equal to the above-mentioned basic standard deviation of the process, one having an average,  $\bar{X}''$ , located  $\frac{1}{3}\sigma''$  below nominal and the other having an average  $\frac{1}{3}\sigma''$  above nominal. The over-all limits for individual units then become  $N \pm 3\frac{1}{3}\sigma''$ . If we designate the distance from the nominal to either limit by  $A$ , then the permissible variation in the process average is  $\pm 0.1A$ .

Our discussions here will be confined to the case of characteristics having substantially Normal distributions and having both maximum and minimum specified limits. In the over-all plan provisions have also been made for characteristics having skew distributions or having a single specified limit, maximum or minimum.

## 2.6 EXPRESSION OF DISTRIBUTION REQUIREMENTS

With the decision to use distribution requirements, the question arose as to how such requirements should be expressed. Would it be adequate to write:

“The distribution of the individual values of characteristic  $X$  of the product shall meet the requirements: (1) average, not outside  $(N \pm a)$ , and (2) standard deviation, not greater than  $b$ .”? Should a clause be added saying that characteristic  $X$  “shall be statistically controlled?”

Recognizing that a requirement is not what is written but what it is interpreted to be, it appeared that such an expression or equivalent is not sufficient to explain the intent nor does it provide criteria for determining when any segment of production may be considered conforming to the intent. What is meant by “the product?” Does the limiting value on the “average” (or the “standard deviation”) apply to each production segment of 10 units, each 50 units, each day’s production, each six month’s production? Can sampling be used? What criteria are to be used for judging whether the distribution of quality of a portion of product is satisfactory? What should be done with the product if it does not meet the criteria?

As with any requirement on the collective quality of an aggregation of like articles comprising a product, the use of distribution requirements brings in special problems on the clarification of the intent. What is really wanted is a flow of product such as would be obtained in a series of random samples of units from a process whose average is continually maintained within stated limits  $(N \pm 0.1A)$  and whose standard deviation does not exceed  $0.3A$ .



With this in mind, the product specification prescribes for any given key characteristic a nominal value,  $N$ , maximum and minimum limits for individual units,  $N \pm A$ , and adds the clause "subject to the distribution requirements of ( $Y$ )."<sup>1</sup> This supplementary specification ( $Y$ ) gives a statistical description of the intent, together with control procedures to be followed in the inspection of the product.

### 3.0 CONTROL PROCEDURES ASSOCIATED WITH DISTRIBUTION REQUIREMENTS

Distribution requirements can be given operationally definite meaning by providing procedures (of the nature of inspection procedures) that define (a) the character and quantity of evidence needed regarding the collective quality of the product as it is made day by day, (b) the criteria for judging when such product may be considered conforming to the intent of the specification, and (c) the treatment or disposition of product units when these criteria are not met.

Three such procedures have been prepared to meet the several conditions that may be encountered in the production of L3 component elements:

1. control chart method,
2. batch method, and
3. three-cell method.

The first two methods permit the use of sampling. For both of these methods the criteria have been so selected that product should be found to be conforming to the distribution requirements practically all of the time if the process is so controlled as to maintain a distribution of individual units with (a) an average within the band,  $N \pm 0.1A$ , and (b) a standard deviation not greater than  $0.3A$ . The third method requires 100 per cent inspection, and while this method may be used at any time at the option of the manufacturer, its use is mandatory whenever a failure to meet the criteria of the other methods is encountered.

To insure that the product shipped continually meets the intent of the distribution requirements, a provision is made for packaging the output in groups of 5 units. This in effect furnishes the user either with random sample groups of 5 from a process which has been shown to be in satisfactory control (control chart and batch methods), or with specially selected groups of 5, the units in each of which have been chosen to meet a particular distribution pattern (three-cell method).

The following sections give the general character of the statistical models that have been set up for the three methods.



### 3.1 CONTROL CHART METHOD

The control chart method is intended for application where production comprises a reasonably steady succession of individual units or small groups of units from a common source; so that units or groups, as produced, may be kept in the order of their production and control chart techniques applied to test results. Under this method control charts are maintained for averages and ranges of samples of 5.

At the outset it is necessary to demonstrate an adequate degree of control of the product in order to be considered eligible for application of this method. Once eligibility has been established, a second and somewhat more lenient set of conditions is used to judge whether this eligibility is maintained. For convenience of reference these two sets of conditions are designated (a) Criterion I, for establishing eligibility (or for reestablishing it), and (b) Criterion II, for maintaining eligibility.

The control charts used in this section are an adaptation of the well-known Shewhart control charts for sample averages,  $\bar{X}$ , and sample ranges,  $R$ , for "control with respect to a given standard." Two modifications of the techniques customarily used in applying the control chart for  $\bar{X}$  have been introduced: (a) a central band rather than a central line has been provided, and (b) a non-parametric requirement has been imposed on seven successive sample averages to limit the excursions of the product average from the nominal value. These modifications are related to the two acceptable distributions referred to in Fig. 2 and reproduced as dotted lines in Fig. 3.

The PA limits of Fig. 3 are the desired minimum and maximum values of the process average, and are the averages of the two acceptable distributions. As indicated in Fig. 2, the PA limits for the process average give the boundaries of the band,  $N \pm \frac{1}{3}\sigma''$ , where  $\sigma''$  is the standard deviation of the two acceptable distributions.

To determine control limits of the control charts for  $\bar{X}$  and  $R$ , consideration is given to the sampling distributions of averages of samples of 5 drawn from such acceptable distributions, as shown in Fig. 3, as well as to the sampling distribution of ranges of samples of 5 from these distributions.

The A5 limits of Fig. 3 (limits to be met by the average of a sample of 5) are 3-sigma control limits for averages of 5, given by

$$N \pm \left( \frac{1}{3}\sigma'' + 3 \frac{\sigma''}{\sqrt{5}} \right).$$

The R5 limit (limit to be met by the range of a sample of 5) is the



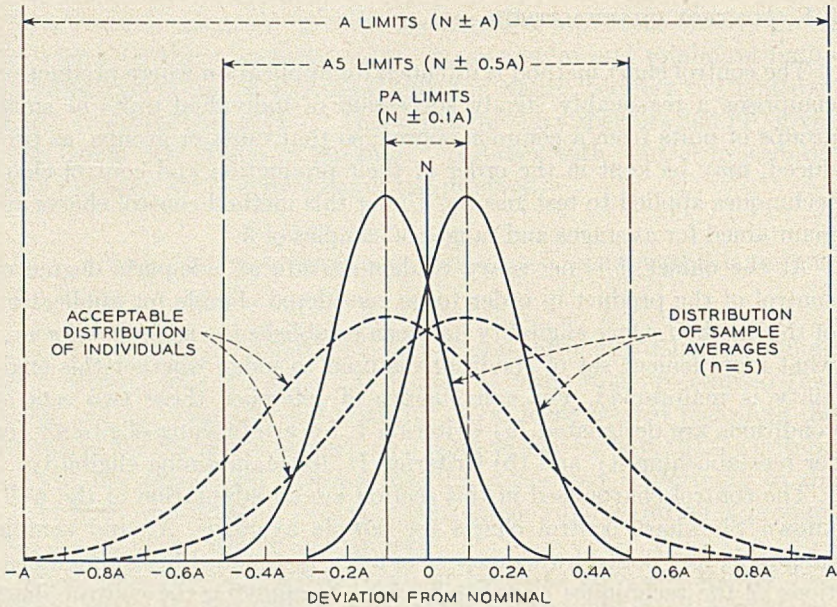

Fig. 3 — Basis of A5 limits and PA limits for sample averages.

customary upper 3-sigma control limit for ranges,  $D_2\sigma''$  (where  $D_2 = 4.918$  for samples of 5). Since the relation between the specified limits for individual units and  $\sigma''$  is expressed by  $A = \frac{1}{3}\sigma''$ , the above limits are related to the specification limits as follows:

$$\text{PA limits} = N \pm 0.1A$$

$$\text{A5 limits} = N \pm 0.5A$$

$$\text{R5 limits} = 1.48A, \text{ max.}$$

At the outset and whenever eligibility to use the control chart method is lost, a 100 per cent inspection rate is required and acceptance is based on the three-cell method (discussed later). Units in groups of 5 are tested as successive samples, and subjected to the following criterion:

#### *Criterion I — Establishing Eligibility*

Eligibility for use of the control chart method is established as soon as 7 consecutive samples or groups of 5 satisfy all the following conditions:

- (a) The averages all meet the A5 limits; and
- (b) The ranges all meet the R5 limit; and



- (c) The seven consecutive averages are not all outside the same PA limit (not all above the upper PA limit or all below the lower PA limit).

When eligibility to use the control chart method is established and so long as it is maintained, sampling inspection may be used. For this inspection, periodic samples of 5 are selected in accordance with a schedule which normally calls for measurement of about 10 per cent of the units produced. The lots represented by such samples are considered as conforming to the intent of the distribution requirements, and hence acceptable for this feature. Provisions are made for further reducing the inspection rate when consistently good control performance is evidenced. During the period of sampling, the following criterion applies to the sampling results:

*Criterion II — Maintaining Eligibility*

Eligibility for use of the control chart method is maintained so long as the results of the current sample satisfy all of the following conditions:

(a) The average either (1) meets the A5 limits; or (2) fails to meet the A5 limits but at the same time all of the 6 preceding consecutive averages meet the A5 limits; and

(b) The range either (1) meets the R5 limit; or (2) fails to meet the R5 limit but at the same time all of the 6 preceding consecutive ranges meet the R5 limit; and

(c) Seven consecutive averages (for the current sample and the 6 preceding samples) do not all fall outside the same PA limit.

(d) No major change is made in raw material, machine set-up or personnel, which may have a significant effect on the quality of the product.

Fig. 4 gives a control chart for averages and ranges of samples of 5 such as might be obtained under the control chart method. The first 20 points (Series A) indicate what might be expected in a series of samples if the process were controlled with its average,  $\bar{X}'$ , at  $N$  and its standard deviation,  $\sigma'$ , equal to the standard value,  $0.3A$ . The next 20 points (Series B) indicate the expected pattern of points if the process average suddenly shifted to a level about  $0.25A$  above the nominal, while  $\sigma'$  remained unchanged. Both sets of points represent the result of random sampling experiments simulating the conditions stated. During Series A the first seven points meet Criterion I and would have established eligibility for using the control chart method. Eligibility would have been maintained for the balance of Series A. Starting with Series



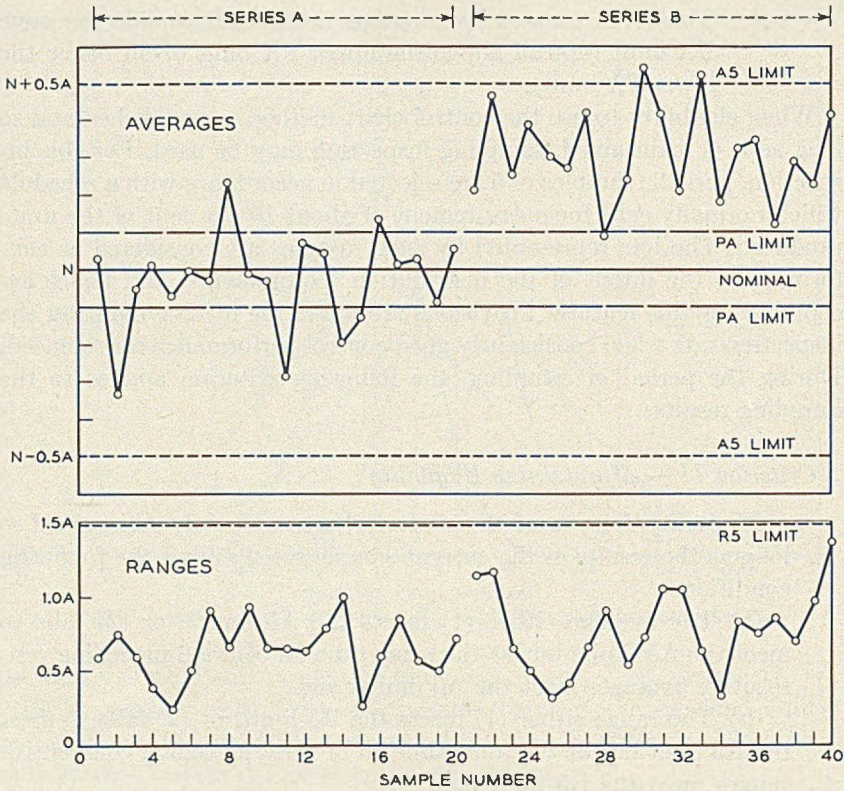

Fig. 4 — Control charts for averages and ranges, samples of 5 from a normal universe.

B, however, a failure to meet Criterion II would have been encountered on the seventh plotted point, which would have caused loss of eligibility to continue using the control chart method. This would have required a reversion to 100 per cent inspection and acceptance by the three-cell method until such time as Criterion I was again met.

Individual units in a lot accepted by the control chart method are to be selected at random from the lot in groups of 5 each, and the five units of each group are to be placed in a single package or otherwise associated so as to remain physically together until delivered to the user.

### 3.2 BATCH METHOD

For some component elements, units are produced intermittently in relatively large groups or batches and subjected collectively to the same manufacturing processes. Under these conditions individual units



or small groups of units do not follow one another through the process in time sequence. Here "order of production" has no meaning for individual units — the only order is the sequence of successive batches.

For this situation a batch method is provided whereby a substantial sample, normally 50 units, is selected at random from each batch. The average,  $\bar{X}$ , and the standard deviation,  $\sigma$ , of the sample are computed and the satisfactoriness of the distribution of the batch is determined by comparing (1) the sample average, and (2) the sample standard deviation with certain limits of allowable variation which have been established. As in the case of the control chart method, consideration is given to the results to be expected in samples from the two acceptable distributions already defined.

The A50 limits, the limits to be met by a sample average, are 3-sigma control limits for averages on either side of the process average band given by  $N \pm (\frac{1}{3}\sigma'' + 3\sqrt{\sigma''}/\sqrt{50})$ , which after substituting  $\sigma'' = 0.3A$ , gives

$$\text{A50 limits} = N \pm 0.23A.$$

The limit to be met by a sample standard deviation is the upper 3-sigma limit of a sampling distribution of standard deviations for samples of 50 from a universe having a standard deviation,  $\sigma''$ . However, in practice the standard deviation is difficult to calculate. In order to simplify calculations, an estimated standard deviation is used instead, computed as follows: Divide the 50 values into random subgroups of 5; find the range,  $R$ , of each of the subgroups; compute the average range,  $\bar{R}$ , and multiply by 0.43. Thus  $\sigma$  (estimated) =  $0.43\bar{R}$ . Considering the sampling distribution of this statistic (0.43 times the average range for 10 samples of 5) as a substitute for  $\sigma$ , we make use of known theoretical relations between the distribution of  $\bar{R}$  for samples of 5 and the standard deviation of the sampled universe. The upper 3-sigma limit of the sampling distribution of  $\bar{R}$  (for 10 samples of 5) is given\* by

$$2.326\sigma'' + 3 \left( \frac{0.864\sigma''}{\sqrt{10}} \right)$$

which, after substituting  $\sigma'' = 0.3A$ , gives  $0.95A$ . From this the limit to be met by the sample standard deviation (estimated as  $0.43\bar{R}$ ) is

$$\text{S50 limit} = 0.41A, \text{ max.}$$

The limits for the sample average must be met by each batch, but

*A.S.T.M. Manual on Quality Control of Materials*, Am. Soc. for Test. Mat., Phila., 1951; see related formula D<sub>2</sub>, p. 114, and factors d<sub>2</sub> and d<sub>3</sub>, p. 115.



provision is made for an occasional failure to meet the limit for the sample standard deviation. Thus the batch represented by a sample will be considered conforming to the intent of the specified distribution requirements, and hence acceptable for this feature if the sample meet the following criterion:

*Criterion III — Batch Acceptability.*

- (a) The average,  $\bar{X}$ , meets the A50 limits; and
- (b) The standard deviation,  $\sigma$ , either (1) meets the S50 limit, or (2) fails to meet the S50 limit but at the same time all of the six preceding consecutive standard deviations meet the S50 limit.

If a batch fails to meet this criterion, the batch must be inspected 100 per cent and acceptance is based on the three-cell method.

Packaging is handled in the same manner as for the control chart method; individual units in a batch accepted by the batch method are to be selected at random from the batch in groups of 5 each and packaged as such for delivery to the user.

### 3.3 THREE-CELL METHOD

Even with the best of conditions things may go wrong from time to time due to any one of a number of causes — changes in raw materials, irregularities in manual operations, faulty performance of processing equipment, etc. As a result, samples taken under either the control chart method or the batch method will sometimes fail to meet the criteria of the methods. In such times of trouble one solution would be to stop production, find the assignable cause, rectify it, and then resume manufacture. This solution, though perhaps ideal in one sense, may not be practical for several reasons:

- (a) Considerable time may elapse before the assignable cause is found and corrected;
- (b) Manufacturing schedules may be disrupted; and
- (c) No answer is provided to the question of what to do with the uncontrolled product already made.

What is needed, therefore, is a procedure for dealing with the finished units when the process is in trouble distribution-wise, a procedure which will permit shipment of some of the product and at the same time assure that the portions shipped will have a proper distribution.

To this end a selection procedure referred to as the three-cell method has been provided. Under this method each unit of product is measured for the characteristic in question and the conforming units are classified



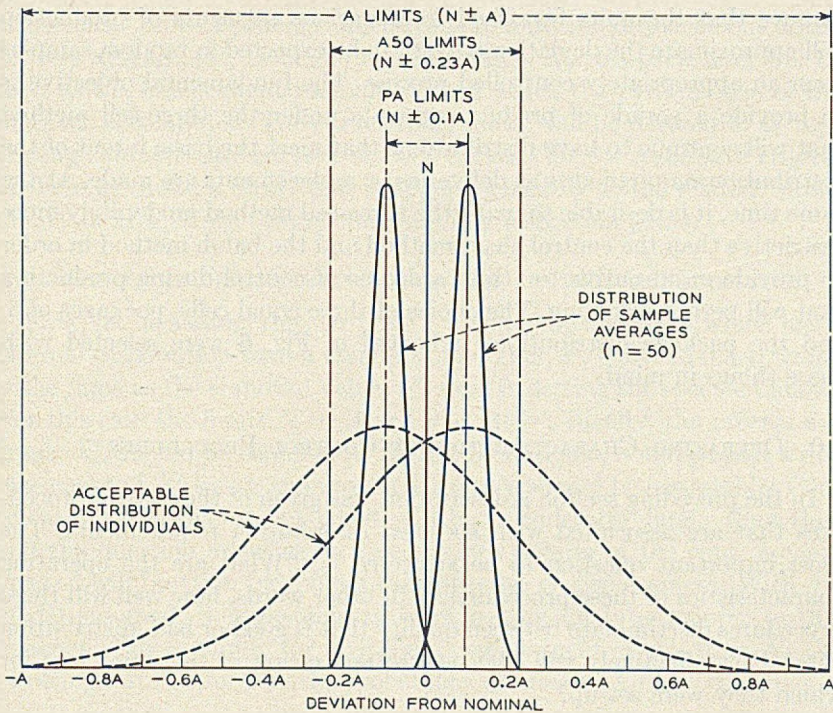

Fig. 5 — Basis of A50 limits for sample averages, batch method.

and sorted into three cells: lower, middle and upper, as shown in Fig. 6. Units are then selected from the three cells in groups of 5 and packaged, the five units in each package to be distributed among the three cells in accordance with one of the two distributions shown at the top of Fig. 6. These selected groups of five are maintained as packages of 5 in merchandise stock and in deliveries to the user.

Units in any cell which are in excess supply at any given time during production and which, therefore, cannot be packaged may be included with subsequent production provided each package of five satisfies one of the two distributions shown in Fig. 6.

For the three-cell method several matters were open to choice — the relative width of the three cells, the number of units in a package, and the required distribution of units in a package. Sampling experiments were run with groups of 4, 5, 6 and 12 and the net effects studied probability-wise for various possible kinds of quality situations that might be encountered in production.

With appropriate choices of these items it is possible to provide as-



surance that the units furnished from various segments of production will approximate the deviation pattern to be expected in random samples from an appropriately controlled process. The fundamental objective is to provide a parade of product-segments under the three-cell method that will continue to have distributions that meet the basic intent of the distribution requirements as deliveries or replacements are made. At the same time, it is desirable to make the three-cell method moderately more restrictive than the control chart method and the batch method in order to provide an incentive to attain a degree of control during production that will permit sampling. The choice of three equal cells, packages of 5, and the package distributions indicated in Fig. 6 were selected with these things in mind.

#### 4.0 OPERATING CHARACTERISTICS OF CONTROL PROCEDURES

In the preceding section a description was given of the control procedures that are associated with specified distribution requirements. The most important question to be answered is: "What are the operating characteristics of these procedures?" In other words, how well will these procedures discriminate between quality that is good or bad, distribution wise? How effectively will they assure realization of the objectives for which they were set up?

For the sake of simplicity the statistical models used to evaluate the expected performance of the control methods are limited to Normal dis-

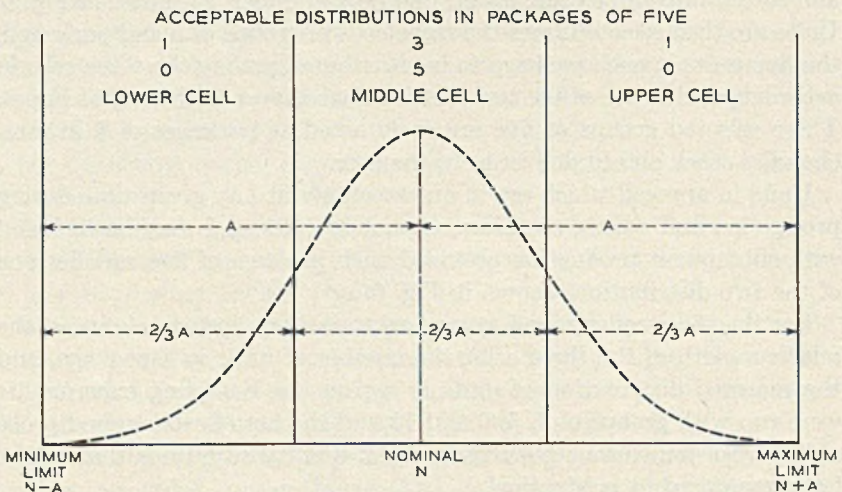

Fig. 6 — Acceptable distributions of units in packages of 5, three-cell method.



tributions.\* Since a primary objective is to limit the displacement of the process average,  $\bar{X}'$ , from the nominal value,  $N$ , this parameter will be used as the independent variable against which the performance of the methods is computed. The curves to be shown will be referred to as "operating characteristic curves" or "OC curves" for the respective criteria of these methods, a term† that is applied generally to the related "probability of acceptance" curves for sampling inspection plans.

#### 4.1 OPERATING CHARACTERISTICS OF THE CONTROL CHART METHOD

First, let us assume that we have a process the output of which has a Normal distribution with a standard deviation,  $\sigma'$ , equal to  $0.3A$ , which is the same as the standard value,  $\sigma''$ , used in setting the specified limits. For this case the limits  $N \pm A$  are  $N \pm 3\frac{1}{3}\sigma'$ . Ideally, the process average,  $\bar{X}'$ , should be centered at  $N$ , but by design it is agreed that a displacement of  $\bar{X}'$  by an amount  $0.1A$  from  $N$  should be acceptable. Conceivably the displacement could well be considerably larger than this, and the question arises as to how the two criteria of the control chart method will function for different magnitudes of displacement. With the model assumed, it is possible to work out an analytic answer to this question. For example, for any given displacement of  $\bar{X}'$ , from  $N$ , the resulting formula for  $P_I$ , the probability of meeting Criterion I, is:

$$P_I = \left[ (1 - P_2^+ - P_2^-)^7 - (P_1^+)^7 - (P_1^-)^7 \right] \left[ (1 - P_4)^7 \right] \quad (1)$$

and the formula‡ for  $P_{II}$ , the probability of meeting Criterion II is

$$\begin{aligned} P_{II} = & \left[ P_0 + P_1^+ \left\{ 1 - (P_2^+ + P_1^+)^6 \right\} \right. \\ & + P_1^- \left\{ 1 - (P_2^- + P_1^-)^6 \right\} + P_2^+ \left\{ (1 - P_2^+ - P_2^-)^6 - (P_1^+)^6 \right\} \\ & \left. + P_2^- \left\{ (1 - P_2^+ - P_2^-)^6 - (P_1^-)^6 \right\} \right] \left[ 1 - P_4 + P_4(1 - P_4)^6 \right] \quad (2) \end{aligned}$$

\* For other distributions this limitation is unimportant for those portions of the criteria that relate to sample averages since averages of samples from a non-Normal universe may ordinarily be considered to be distributed Normally. See W. A. Shewhart, *Economic Control of Quality of Manufactured Product*, D. Van Nostrand Co., New York, 1931, pp. 180-184. But due among other things to lack of independence of  $\bar{X}$  and  $R$  for skew distributions, the results given here should be considered only as reasonably close approximations for the degrees of non-Normality that may be encountered in practice.

† A term first used in the late 1930's by Capt. H. H. Zornig, of the Ballistic Research Laboratories, at Aberdeen Proving Ground.

‡  $P_{II}$  is an unconditional probability in the sense that it does not involve the condition that previously there was a sequence of 7 samples satisfying Criterion I and no intervening sequence of 7 samples not satisfying Criterion II.  $P_{II}$  has been used as an approximation to, although possibly somewhat less than, the corresponding conditional probability. A similar consideration applies to  $P_I$ .



where each of the above  $P$  symbols designates the probability that a sample average (average of a random sample of 5 units) will fall in the band associated with that symbol in the following tabulation:

Symbol	Band
$P_2^+$	Above $+0.5A$
$P_2^+$	$+0.5A$ to $+0.1A$
$P_0$	$+0.1A$ to $-0.1A$
$P_1^-$	$-0.1A$ to $-0.5A$
$P_2^-$	Below $-0.5A$

and  $P_4$  = probability that a sample range (range of a random sample of 5 units) will fall above its upper control limit,  $1.48A$ . ( $P_4 = 0.0044$  for  $\sigma' = 0.3A$ .)

The OC curves for Criterion I and Criterion II computed from these formulas are given in Fig. 7(a), when  $\sigma' = 0.3A$ . These show how the control chart method serves on a probability basis as a band-pass filter for a manufacturing process, permitting the introduction of and allowing the continuance of sampling so long as the process average is maintained reasonably close to the nominal, and imposing an increasingly higher barrier to acceptance by sampling when the displacement of the process average from  $N$  is increased, thus forcing the use of the three-cell method. Examination of these curves shows that Criterion I is more stringent than Criterion II, as it should be.

Suppose for the moment that both Criterion I and Criterion II omitted condition (c) relating to seven successive sample averages. The OC curves in this case are shown in Fig. 7(b) with the designation "I, II, less c." It is seen that this requirement relating to seven successive averages is most important. Without it the criteria, particularly Criterion II, would be very ineffective in controlling excursions of the process average.

A second question of importance is: "What happens if the specified dispersion limits ( $A$  limits) are improperly set or if the process dispersion changes to produce this effect?" In other words, what are the operating characteristics of the procedure when  $\sigma' \neq 0.3A$ ? This is shown in Figs. 7(c) and 7(d) for Criterion I and Criterion II respectively, where the values of process standard deviation ( $\sigma'$ ) are expressed as fractional values of  $A$ .

#### 4.2 OPERATING CHARACTERISTICS OF THE BATCH METHOD

For the batch method the procedure is essentially a lot acceptance procedure and except for permitting an occasional failure of the sample



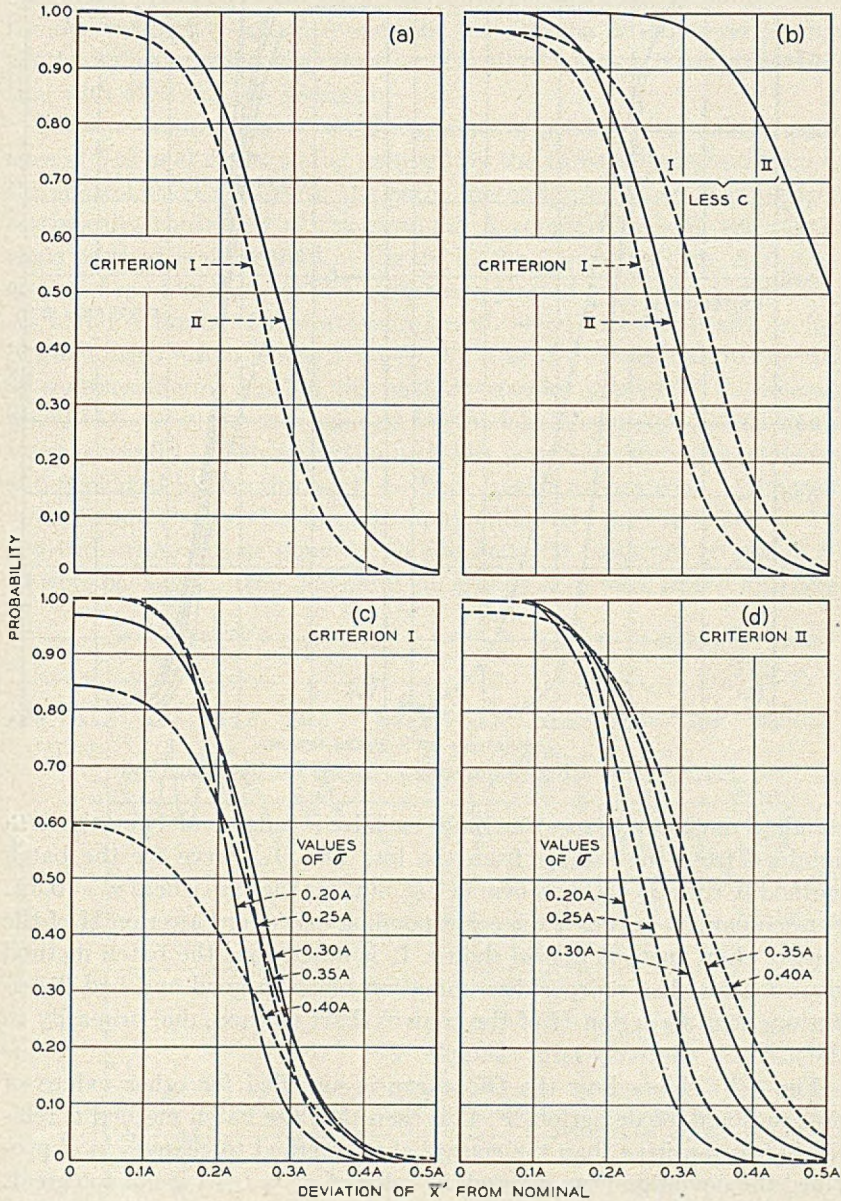

Fig. 7 — Operating characteristic curves for control chart method.



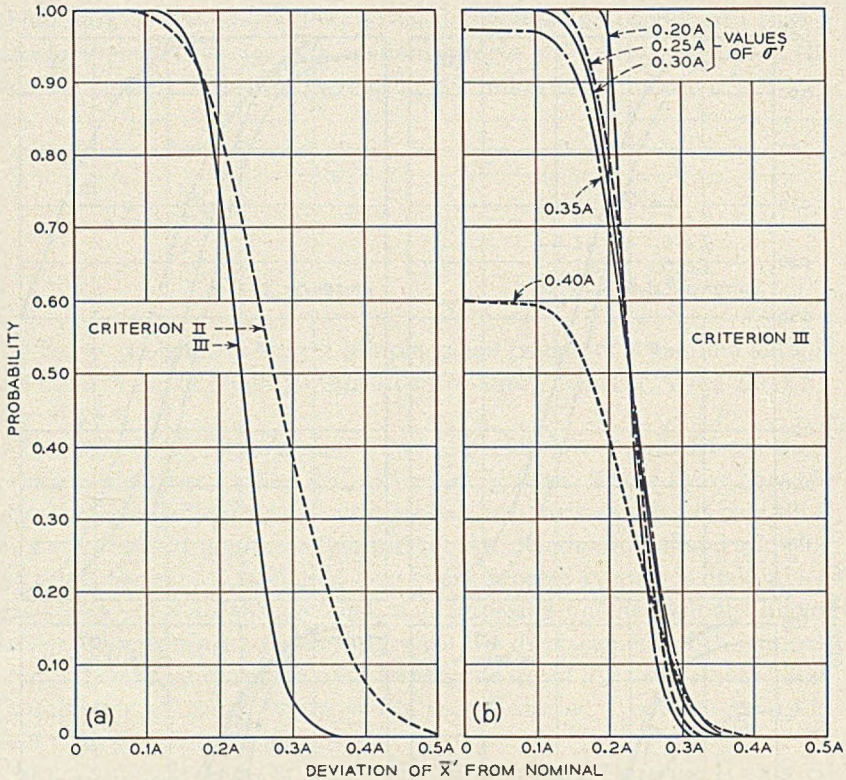

Fig. 8 — Operating characteristic curves for batch method.

standard deviation to meet its limit, each lot is judged solely on the data obtained from the sample from the lot. The OC curve for the batch method (Criterion III) is shown in Fig. 8(a) for the case where  $\sigma' = 0.3A$ . For comparison purposes the corresponding curve for Criterion II of the control chart method is also shown. It is noted that the batch method gives a somewhat sharper discrimination between good and bad distributions than Criterion II of the control chart method, due primarily to the use of a relatively larger sample.

Fig. 8(b) shows how the OC curve is modified for other values of process standard deviation,  $\sigma'$ . It is seen that the batch method is relatively less sensitive than the control chart method to changes in  $\sigma'$  provided the deviation from a standard value of  $\sigma'' = 0.3A$  is not too great.

#### 4.3 CHARACTERISTICS OF THE THREE-CELL METHOD

The operating characteristics of the three-cell method cannot be evaluated probability-wise in the manner given for the other two methods.



However, the manner in which the three-cell method serves as a continuous corrective influence over the distribution of delivered product can be indicated by a few diagrams, for all of which a Normal distribution with  $\sigma' = 0.3A$  is assumed.

The running average of small segments of product delivered in packages of 5 is held closer to the nominal by the three-cell method than by the control chart method or the batch method, even when the process is statistically controlled at the nominal. A comparison with the control chart method is illustrated in Fig. 9. In the upper chart are shown averages of random samples of 5 units each, plotted on a control chart with A5 and PA limits. These are samples obtained experimentally from a Normal distribution whose average,  $\bar{X}'$ , was at the nominal for the first 20 samples (Series A). For the next 20 samples (Series B) the average was 0.15A above the nominal and for the last 20 samples (Series C) the average was 0.15A below the nominal. The same units were then classified and packaged by the three-cell method. In this experiment, as the units of each sample were classified, as many units were packaged in 1-3-1 or 0-5-0 distributions as possible. Of the first 100 units (20 groups of 5), 95 were packaged. After 200 units (40 groups of 5) were sorted into cells,

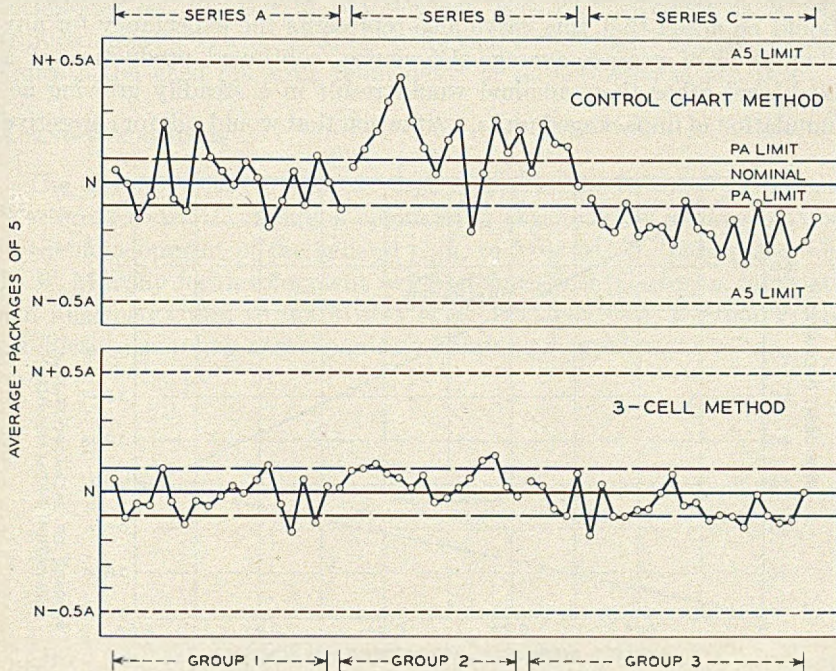

Fig. 9 — Comparison of control chart and three-cell method, averages of packages of 5.



175 were packaged. Of the 25 units not packaged, 24 were in the upper cell and 1 unit did not meet the *A* limits. At the end of the experiment 295 of the 300 units had been packaged. Of the 5 units not packaged, 3 remained in the upper cell, and 2 did not meet the *A* limits. The averages of the packages are shown in the lower chart of Fig. 9. For comparison, the PA limits are also shown on this chart. It is apparent from these two charts that the three-cell method yields packages whose averages are held closer to the nominal than are averages for packages from the control chart method.

The corrective effect of the three-cell method is further illustrated by Fig. 10, which shows the average of product packaged by the three-cell method as a function of the process average. This curve is for "long term" conditions, that is, it represents the expectancy for any given level of process average. This corrective effect is purchased at the expense of not packaging a portion of the product while the process average is not at the nominal value. However, as already noted, the unpackaged portion may be packaged with subsequent product if the process average subsequently deviates from the nominal in the opposite direction.

The percentage that can be packaged is also shown in Fig. 10 as a function of the deviation of the process average from the nominal. It should be noted that this curve also represents the expectancy for any given level of process average. Of course, continued production at a fixed level other than nominal would result in a steadily growing accumulation of unpackaged units, a situation that would call for corrective

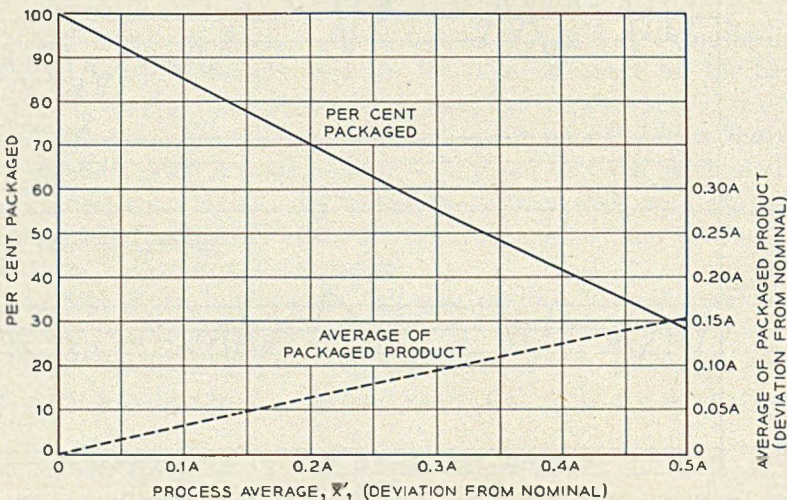

Fig. 10 — Expectancy curves for three-cell method.



action on the process. Close to 100 per cent packaging can be assured by introducing a negative bias in the process to compensate for the effect of a prior positive bias, and vice versa.

## 5.0 CONCLUSIONS

The L3 system's need for holding transmission performance close to the design center, both within short segments and over the full span of the transcontinental line, has called for a high degree of statistical uniformity of critical characteristics of component elements. The statistical quality control methods are imposed from the point of view of the user in the interests of the over-all economy of system design. The control procedures are designed to provide at all times a parade of suitably distributed batches of production units, and at the same time to furnish incentives for controlling manufacturing processes at the design center.

Any enterprise of this kind, involves the closest of interplay and adjustment between design and production interests. Many cases of incompatibility of design desires and production capabilities had to be cleared in the early stages of the work. Intensive process quality control work and the development of a number of ingenious processing techniques on the part of the Western Electric Company have contributed greatly to what has been achieved. Experience will undoubtedly indicate the need for some refinements or adjustments in the plan.

## ACKNOWLEDGMENTS

The authors wish to express their appreciation to members of the Western Electric Company's engineering organization for cooperation in the development of the general plan, to Miss M. N. Torrey and Dr. R. B. Murphy for development work on statistical features of alternate and final plans, and to the Misses E. F. Lockey and J. Zagrodnick for conducting sampling experiments and making computations.







# The L3 Coaxial System

## Application of Quality Control Requirements in the Manufacture of Components

By R. F. GARRETT, T. L. TUFFNELL and R. A. WADDELL

(Manuscript received April 27, 1953)

*The application of quality control procedures, in addition to conventional maximum and minimum limits, is an important factor in the manufacture of components for the L3 carrier repeaters. In this application, control chart techniques are used for providing assurance that the average of each characteristic subject to control is held close to a desired value and that, collectively, individual units have a desired distribution about this average value. The three-cell method is frequently used under certain conditions encountered in the manufacture of these components when sampling procedures cannot be applied. This method consists of measuring each unit of product, classifying conforming units into one of three cells and the selection of groups of five units each to provide the desired distribution. Case histories of a number of factory applications of these methods are presented.*

### 1.0 INTRODUCTION

#### 1.1 GENERAL

Statistical quality control methods are well known and useful industrial tools for economically controlling quality during manufacture. These methods have as one of their goals the shipment of product meeting the end requirements for a particular quality characteristic. The application of such methods also makes possible the delivery of a product whose quality is statistically uniform as, for example, having a distribution whose average is maintained consistently close to the design center. Bell Telephone Laboratories engineers have made use of these principles in the development of the new L3 long distance carrier system which will employ hundreds of repeaters in tandem.

An important factor in the application of statistical quality control methods is the specification of distribution requirements in addition to



conventional maximum and minimum limits for the characteristics of many of the components manufactured for the new repeaters. The introduction of distribution criteria where maximum and minimum are customarily specified requires a number of operations which are supplementary to normal procedures. The relatively simple act of identifying good product becomes complicated by the need of more extensive measurements, the recording of data, computations, plotting of charts and the active participation of technical personnel in the administration of the procedures.

The first step in the program was the development of practical statistical quality control techniques which would be applied under the special circumstances attending the design and manufacture of components of L3 carrier repeaters. This required careful study by Bell Telephone Laboratories and the Western Electric Company and resulted in the development of a general specification which provides procedures and criteria for maintaining the average value of a quality characteristic close to a nominal value and for obtaining as nearly as possible a random distribution of individual values around the nominal. The purpose of this paper is to discuss the procedures thus developed with emphasis on their relationship to manufacturing processes and to describe the problems encountered and solved in the course of application to the manufacture of components of L3 carrier repeaters. Detailed mathematical derivations and terms will be generally omitted since the theories underlying the principles involved are covered by another article.<sup>1</sup>

## 1.2 PARTICIPATION IN DEVELOPMENT

Normal practice in the creation of new product designs is for the development and construction of the first models to be handled by the design engineers. This work usually includes discussions with the manufacturing organization in order to minimize the costs and to utilize existing or most effective manufacturing facilities and various preferred or stocked materials. In the case of the critical components of the L3 carrier amplifiers, a design change in one component resulting from the transition from development to production requires especially close study and may require an adjustment in other components in order to compensate for the one being changed. Knowledge of the behavior of regular manufacturing facilities and methods used in the fabrication of preproduction units provides considerable assistance in establishing specification limits which are compatible with the product design and manufacturing process capabilities.



### 1.3 SEQUENCE OF MANUFACTURING OPERATIONS

The application of distribution requirements places added emphasis on the proper sequence of the various operations required for the fabrication of the product. Normally, any assembly or finishing operation following a process adjustment of a particular characteristic is designed to keep that characteristic within maximum and minimum limits in the final state. Such procedures often fail to satisfy the desired distribution and it is necessary to rearrange the sequence of operations. Once the proper sequence is established it must be rigidly maintained.

### 1.4 TESTING

As a result of refinements in design and in production methods employed for the critical components of the L3 amplifiers, the design engineer has in many instances been able to specify limits closer than ever before attained. The specification of such close limits may tax the precision of factory testing equipment and in many cases it has been necessary to develop and construct new electrical and mechanical inspection facilities. Measurement reproducibility as well as accuracy in terms of absolute values is important since the measuring instrument ordinarily indicates variations in repetitive readings, even though the product being measured remains constant. Once the characteristics of the measuring instrument are determined and used as a basis for the specification of limits, the measuring facility becomes an important part of the distribution control system and must be controlled the same as all other elements of the system. This means careful watch over the maintenance of factory inspection facilities so that these characteristics are controlled. Obviously, an adjustment made on the measuring instrument in the course of regular maintenance which introduces a significant bias or shift, even though well within accuracy limits, may have to be taken into consideration in the use of the instrument. One method of minimizing this problem is to employ stable fixed standards whose characteristics are numerically equal to or near the nominal value of the products being tested. Such standards can be used for either calibrating the instrument or as comparison standards in the actual measurement of the product. These auxiliary standards must still be periodically checked and extreme care taken to prevent any shift in their characteristics.

## 2.0 QUALITY CONTROL METHODS

### 2.1 CONVENTIONAL STATISTICAL QUALITY CONTROL METHODS

The concept of control as used here includes the use of data resulting from measurements made on product produced under the same essential



conditions. The curve which can be used to represent the observed frequency distribution of data obtained under controlled conditions may, for most practical purposes, be illustrated by the shape shown in Fig. 1. The characteristics of this curve are mathematically represented by the average  $\bar{X}$  (arithmetic mean) and the standard deviation  $\sigma$  (the root-mean-square deviation of individual values from their average  $\bar{X}$ ).

The control chart techniques as originally developed by Walter A. Shewhart<sup>2</sup> of Bell Telephone Laboratories provide economical methods for measuring and evaluating the characteristics of such distributions. In practice they are useful in obtaining an estimate of the capabilities of manufacturing processes, sometimes referred to as the "natural tolerances" of the process and in maintaining control at that quality level. In general, a process having a controlled distribution with an average  $\bar{X}$

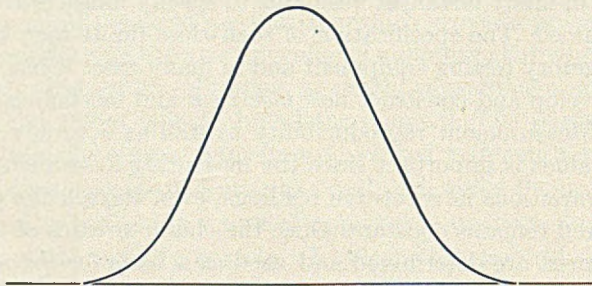

Fig. 1 — The ideal frequency distribution for observations obtained under controlled conditions.

and a standard deviation  $\sigma$  will result in practically all of the individual units of product falling within the band  $\bar{X} \pm 3\sigma$ .

Conventional quality control techniques are used by both the design and manufacturing engineers. The design engineer, in order to specify tolerances compatible with the design needs and the capabilities of economical commercial manufacture, applies the techniques to a reasonable number of preproduction models or possibly to a limited quantity of initial regular production. The manufacturing engineer in turn uses the techniques for determining the capabilities of existing or new manufacturing facilities in order to select the most effective facilities and methods. The techniques are also effective tools for locating and eliminating assignable causes of manufacturing variations, while their continued use as a regular part of the manufacturing process provides an excellent contribution to effective quality control. In these applications there usually exists a substantial margin between the  $\pm 3\sigma$  variation around the nominal value and the specification limits. This is illustrated



as specification limits, 1-1 in Fig. 2. The margin is attained either by improvement of the manufacturing processes or by widening the specification limits. This means that occasional out-of-control conditions can be indicated by the control chart without the factory being faced with a shut down in production, provided that corrective measures are taken before the magnitude of the deviations results in any significant quantity of the product failing to meet the specification limits.

The contrasting situation occurs where the spread between the maximum and minimum specification limits becomes equal to or less than the 6-sigma spread of the manufacturing process, as shown in Fig. 2. For specification limits 2-2, production must be stopped every time an out-of-control condition is indicated or 100 per cent inspection introduced until the cause of the condition is located and eliminated. In the case of specification limits 3-3 in Fig. 2, 100 per cent inspection must be continuously applied in order to eliminate non-conforming product as shown in the shaded portion under the distribution curve.

2.2 SPECIAL STATISTICAL QUALITY CONTROL METHODS

The special statistical quality control techniques developed for L3 carrier components present a special problem. Here they become an actual part of the product specification, rather than an aid in meeting it, although conventional methods may still be useful for process control. It was recognized that any attempt to express specification limits in terms of a  $\pm 3\sigma$  variation around the nominal would have to include

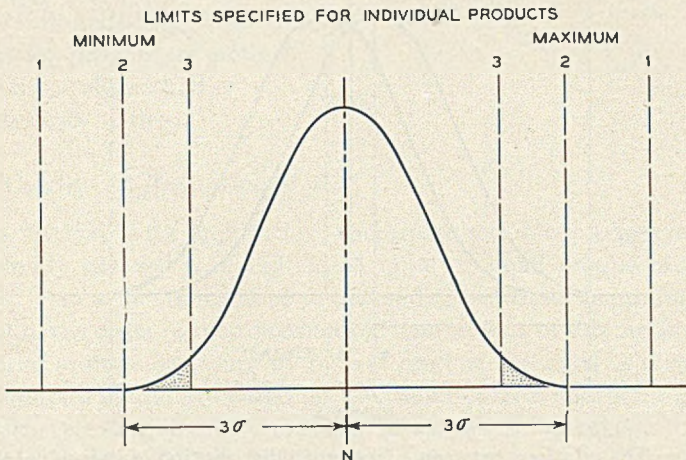

Fig. 2 — The relations between a frequency distribution of individual units of product and various specified maximum and minimum limits.



allowances for the process average to vary a reasonable amount around this nominal. The methods developed and included in the general specification allow the process average to vary within a band of  $\pm \frac{1}{3}\sigma$  around the nominal which results in limits for individual units of product, designated as "A" limits in the specification, equal to nominal  $(N) \pm 3\frac{1}{3}\sigma$ . The value chosen represents a balance between the needs of the operating requirements of the product and the difficulties of maintaining closer controls in the factory.

In Fig. 3 the permissible variation of individual units of product is represented by a Normal distribution curve displaced  $\pm \frac{1}{3}\sigma$  from the nominal  $N$ . Since the specification limits are represented by  $\pm A$ , the allowable variation in the process average is  $\pm 0.1A$ .

This is a severe requirement, for in spite of the care employed in collecting data during the preproduction period for computing the "natural tolerance" of a manufacturing process, there is always the danger that all the variations which are an unavoidable part of regular production do not occur during the time data are collected. There could be periods after manufacture has started when the factory could not determine whether the out-of-control condition was one which should be promptly eliminated or whether some important characteristic of the process which had not occurred earlier had made its appearance. At this stage it is important to have available some method for sorting product already manufactured which will meet the desired distribution pattern

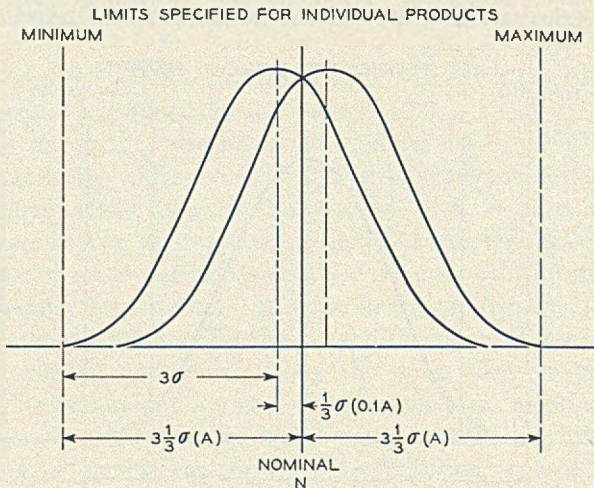

Fig. 3 — The relations between a frequency distribution of individual units of product and specified maximum and minimum limits when the average or nominal is allowed to vary  $\pm \frac{1}{3}\sigma$ .



so that large inventories will not accumulate in the factory and delivery commitments can be met. Such a method requires the measurement and classification of the product into groups or cells, followed by the selection of units from such cells in accordance with a required distribution. Although this method requires 100 per cent inspection instead of sampling inspection permitted by the use of control charts it was estimated that this method would be used extensively until new manufacturing processes were thoroughly proven and sufficient data collected to fully establish a process capability.

### 2.3 THE GENERAL SPECIFICATION

Anticipated application required consideration and development of methods for the wide variety of manufacturing conditions likely to be encountered in the production of such items as coils, condensers, resistors and vacuum tubes. These products may be manufactured at widely separated factories for assembly in equipment at still another location. In order to assist in the description of the factory applications, to be presented later, the methods developed which are referred to as "distribution requirements" in the general specifications are listed and briefly described below. With the exception of the Records method, distribution requirements are applied to only one characteristic of a product. If application to more than one characteristic is desirable a method suitable for use as a basis for shipment of the product is selected for the most important characteristic and the Records method is specified for the remaining characteristics.

1. Continuous production method.
2. Batch production method.
3. Three-cell method.
4. Records method.

#### 2.31 *Continuous Production Method*

This method is for application where production comprises a reasonably steady succession of individual units or small groups of units of product from a common source so that individual units as produced may be kept in the order of their production. The criteria of this method apply to a series of units or groups of units of product arranged in the order of their production and are based on the use of control charts for averages and ranges for samples of 5 units each. Examples of typical control charts are shown in Figs. 4 and 5.

The inclusion of an allowance for the long time variation in the level



of the process average results in the use of two sets of control limit lines for averages in place of the one used for conventional methods.<sup>3</sup> These consist of:

- (1) A relatively narrow band equal to  $N \pm 0.1A$  ( $N \pm \frac{1}{3}\sigma$ ), designated in the general specification as "D" limits.
- (2) The normal 3-sigma limits for averages of samples of 5 units

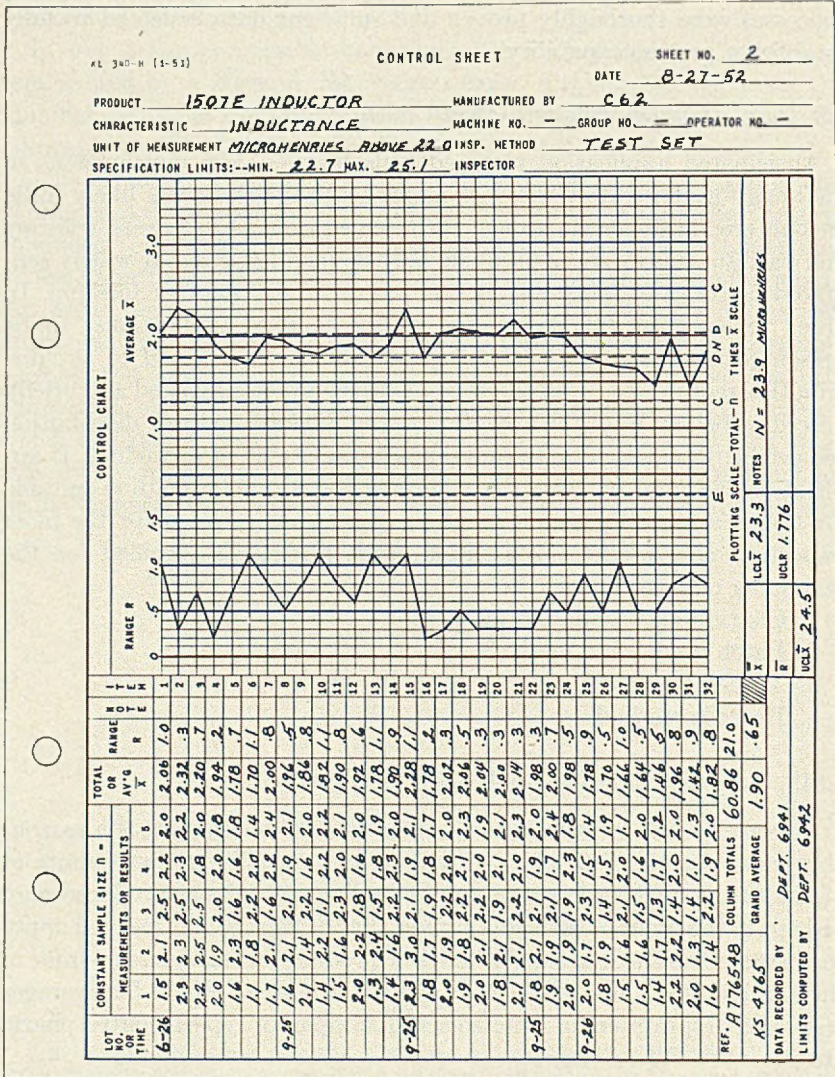

Fig. 4 — A typical control chart (1507E inductor).



placed outside the first band equal to  $N \pm 0.5A$ , designated in the general specification as "C" limits.

The control limit for ranges is the customary upper 3-sigma value computed by regular methods,<sup>3</sup> and equals  $1.48A$ . This is designated in the general specification as the "E" limit. The product specification requirements are expressed in the form  $N \pm A$  so that the calculation of

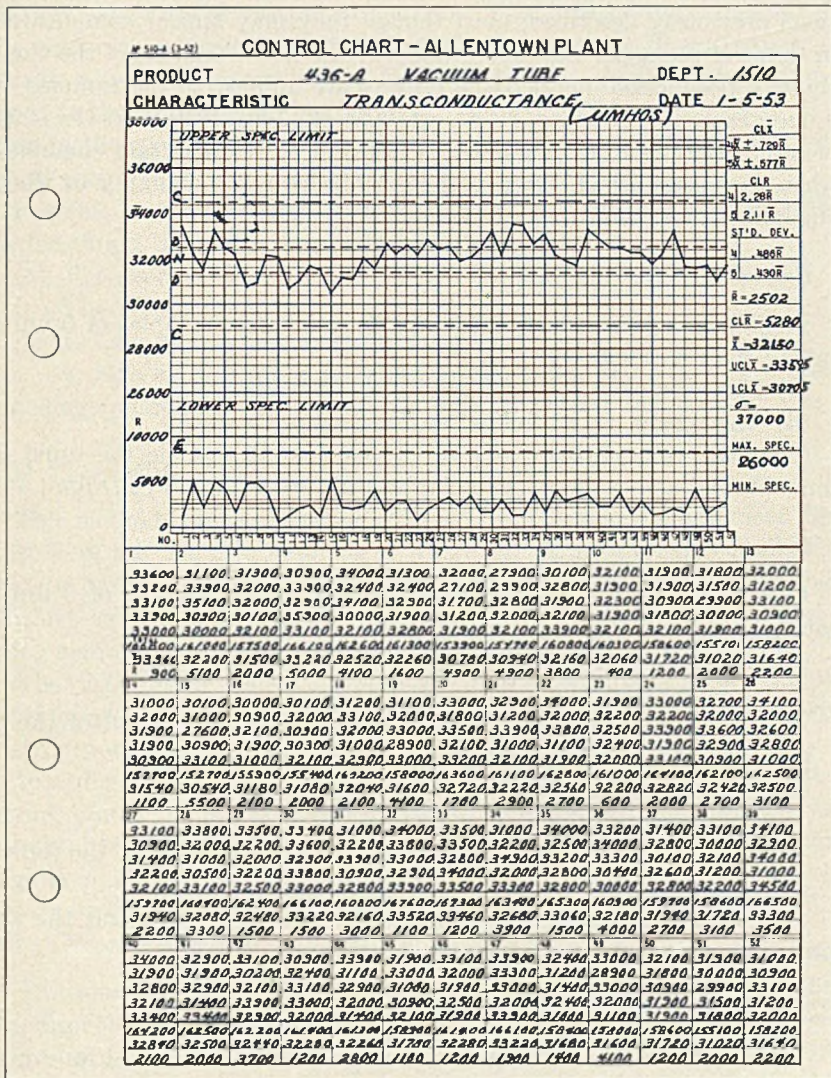

Fig. 5 — A typical control chart (436A vacuum tube).



the various control limits for factory use is a relatively simple operation. A typical example is the 1507A Inductor where the inductance requirement is expressed as  $283.9 \pm 20$  microhenries.

Then the "C" limits =  $283.9 \pm 0.5 \times 20$ , = 293.9 max., 273.9 min. microhenries, and the "E" limit =  $1.48 \times 20 = 29.6$  microhenries.

Since the distribution requirements are a part of the specification, the product must meet rather exact criteria in terms of the limiting conditions previously described, even though they may appear complicated in terms of the usual manufacturing procedures. In the case of the Continuous production method the criteria are applied to the samples of 5 units each, in two steps, (1) to establish eligibility, either at the start of production or when eligibility is lost and (2) to maintain eligibility when once established. Prior to the establishment of eligibility or when eligibility is lost the three-cell method is applied.

#### *Criterion 1*

Eligibility is established as soon as 7 consecutive samples of 5 units satisfy the following:

- (a) The averages,  $\bar{X}$ , all fall within the *C* limits.
- (b) The ranges, *R*, all fall below the *E* limit.
- (c) Seven consecutive averages,  $\bar{X}$ , are not all outside the same *D* limit (not all above the upper *D* limit or all below the lower *D* limit.)

#### *Criterion 2*

Eligibility is maintained as long as each current sample of 5 units satisfies the following:

- (a) The average,  $\bar{X}$ , either
  1. falls within the *C* limits or
  2. falls outside the *C* limits but at the same time all of the 6 preceding consecutive averages fall within the *C* limits.
- (b) The range *R* either
  1. falls within the *E* limit or
  2. falls outside the *E* limit but at the same time all of the 6 preceding consecutive ranges fall within the *E* limit.
- (c) Seven consecutive averages  $\bar{X}$  (the current sample and the six preceding samples) do not fall outside the same *D* limit.

### 2.32 *Batch Production Method*

This method is for application where production consists of intermittent batches of 50 or more units, all of which have been made under the



same essential conditions with respect to materials, parts, workmanship and processing. The criteria of this method apply to a series of batches or lots of product arranged in the order of their production and are based on the use of control charts for averages and standard deviations for samples of 50 units each.

The control limits for averages are for 50 units of product and also include an allowance for the long time variation in the level of the process average. They are represented by a band  $N \pm 0.23A$  which is equal to the customary<sup>3</sup> 3-sigma control limits for averages of 50 units placed outside a band corresponding to  $N \pm 0.1A$  ( $N \pm \frac{1}{3}\sigma$ ) and are designated in the general specification as "C" limits. In this method the "E" limit in the specification is the control limit for the standard deviation ( $\sigma$ ) of a sample of 50 units and equals  $0.41A$ .

For this method a batch, represented by the sample, is considered conforming if the sample meets the following criterion.

- (a) The average  $\bar{X}$ , falls within the C limits.
- (b) The standard deviation,  $\sigma$ , either:
  1. falls within the E limit; or
  2. falls outside the E limit but at the same time all of the 6 preceding consecutive standard deviations fall within the E limit.

### 2.33 *Three-Cell Method*

This method is for application whenever the product fails to meet the criteria of the first two methods or where the manufacturing conditions dictate its use. When maximum and minimum limits are specified the method consists of testing or measuring each unit of product and classifying conforming units in one of three cells: Lower, Middle or Upper.

The distribution is shown graphically in Fig. 6. Groups of 5 units of product are selected from this classification so as to meet one of the two distributions given in Table I and maintained as such for shipment.

In order to provide a graphic record of whether or not the manufacturing process is in statistical control, this method includes procedures for obtaining control chart data based on samples of product taken from regular production before classification.

### 2.34 *Records Method:*

This method is for application when it is not practicable to impose the requirements of the other methods but it is still desirable to systematically maintain a graphic history of the measurements made on a quality characteristic. Action required to maintain the distribution of



the product within the limits implied by the control charts is left to the initiative of personnel administering the application of the method.

The records are based on measurements on samples of 5 units each selected at random prior to the regular inspection of individual units for conformance. The number of such samples should be adequate to provide a control chart record of the quality of the product.

In all of the methods described except the one requiring records only, the final product is packaged in groups of 5 units for shipment. When an order calls for a quantity other than an integral multiple of 5, the fractional part of the group shall consist of units randomly selected from a group which has been previously packaged.

### 3.0 FACTORY APPLICATION

#### 3.1 GENERAL

The Distribution Requirements are being applied to 91 components consisting of 31 different codes of product used in the L3 carrier repeaters. In addition, Record methods are applied to 66 characteristics of the line and office amplifiers.

The components involved are identified in Table II.

These products require the maintenance of over 100 control charts in the factory in a form suitable for reproduction since engineering review of the results is necessary for adjustment of limits. Many of the charts are prepared and handled by factory personnel who required and received training in order to provide assurance of accurate results. Comprehensive instructions were prepared in order to assist in this training.

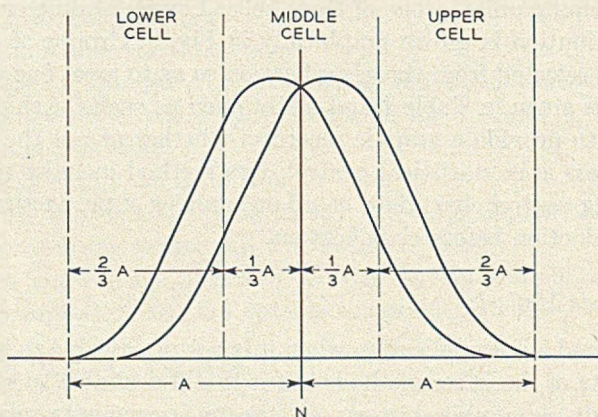

Fig. 6—A three-cell pattern superimposed on a frequency distribution of individual units of product when the average is allowed to vary  $\pm\frac{1}{3}\sigma$ .



TABLE I

Distribution	Number of Units		
	Lower Cell	Middle Cell	Upper Cell
1	1	3	1
2	0	5	0

A number of special forms were developed to facilitate the preparation of control charts, two of which are shown in Fig. 4 and Fig. 5. Since these control charts are directly related to the manufacture of the product, the cost of their preparation is included in the cost of the product, either by having the operation handled by production personnel or by the application of appropriate cost factors. This required in many cases the preparation of specific instructions to factory personnel in the form of manufacturing layouts which are also used as a basis for computing manufacturing costs and wage incentive rates.

One of the most serious problems in the application of these methods is the accumulation of large inventories of product when the manufacturing processes fail to meet the distribution requirements. In the case of regular maximum and minimum limits, procedures for the disposal of non-conforming product are direct and well known. In the case of distribution requirements however, there may be substantial quantities of product which meet the "A" limits but fail to meet the required distribution. Product which originally cannot be packaged must be put aside with the hope that product subsequently manufactured will result in combinations which will meet the required distribution. The discussion of applications to the products listed in Table II will show that a great measure of success has been realized in the solution of this problem.

TABLE II

Description	Number of Different Codes	Number of Different Repeater Components
Controlled pitch single layer coils (AWA, 302, 320, 1500, 1507 type).....	18	18
Mica capacitors (500 type).....	4	21
Quartz disc capacitors (505 type).....	3	3
Carbon deposited resistors (200 type).....	2	45
Quartz input-output transformer (2504 type).....	1	1
Vacuum tubes.....	3	3
Total.....	31	91



### 3.2 APPLICATION TO COILS

#### 3.21 *Single Layer Type Inductors*

The problems encountered in the application of quality control techniques to the various codes of the single layer type coils follow a similar pattern so that a discussion of any one code covers many of the conditions common to the entire group. The early application of distribution requirements to L3 carrier coil characteristics was associated with the development of the 1500-type inductor commonly referred to as the "Splitting Coil". This coil derives its name from its primary circuit function of separating or splitting the transformer winding capacitance from the input capacitance of the amplifier vacuum tube. The circuit in which this coil is used permits an estimated variation in inductance from a desired value of approximately  $\pm\frac{1}{4}$  per cent, which includes manufacturing deviation, aging and temperature effects. A coil of this type having such close tolerances could not be produced economically with normal manufacturing methods. At this point the use of control chart methods played an important part in the development of tolerances and measuring techniques. The control chart techniques combined with the simultaneous development of manufacturing methods and sources of critical raw material have permitted the widening of limits of coils under the general distribution specification using "A" limits of  $\pm 1$  per cent in place of the originally estimated limits of  $\pm\frac{1}{4}$  per cent without a controlled distribution.

The splitting coil consists of a single layer winding wound on a ceramic form under a tension of 50 to 75 per cent of the wire breaking strength. The winding is terminated in lead wires which have been secured in holes located in the ceramic core transverse to the axis of the coil. The use of the ceramic core on this coil has reduced the temperature and aging effects to the point of becoming negligible, due to the nature of the core material and winding conditions. Major factors affecting the inductance variation are as follows:

a. Diameter of wire — standard commercial tolerances on wire of the sizes used, equalling  $\pm 0.0003$ " will produce a variation in coil inductance of approximately  $\pm 0.15$  per cent.

b. Diameter of core — a variation of core diameter of  $0.0005$ " will produce a variation of approximately  $\pm 0.5$  per cent in the coil inductance.

c. Length of winding — a variation in the nominal length of winding of  $\pm 0.001$ " will result in a variation in inductance of about  $\pm 0.13$  per cent.



During the initial period of manufacture of these inductors, it was found that the seriousness of the variations in inductance, contributed by the wire diameter tolerance, could be minimized by selection of the wire stock. Experience has indicated that because of the small amount of wire used per coil, this procedure can be followed without undue losses.

The variations contributed by the core diameter tolerance have been minimized by the introduction of a ground core having a diameter tolerance of  $\pm 0.0002''$ . By virtue of the manufacturing methods introduced by the core manufacturer to meet this close diameter tolerance, a fairly normal distribution of the core diameter was obtained.

In addition to the variables due to the material used for these coils there were substantial variations in inductance inherent in the winding machines and operator winding techniques particularly in the attachment of the wire to the terminals. Early control charts showed an erratic

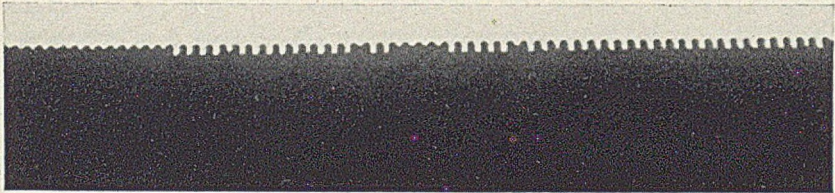

Fig. 7 — A shadowgraph of a coil winding showing irregularities in the wire spacing due to non-uniformity in pitch control of winding machine.

variation of inductance which was traced chiefly to backlash in the winding machine.

Fig. 7 is a shadowgraph of the coil winding showing the irregularities in the wire spacing due to non-uniformity in the pitch control of the winding machine. In addition to this variation, trouble was experienced in maintaining pitch control at the end of the winding due to the necessity of sanding the lead before splicing to the terminal. This latter variation was brought under control by the introduction of a type of wire which can be soldered to the terminal without mechanically removing the insulation, thus avoiding the loss of the winding machine accuracy of spacing and tension. After numerous machine modifications, satisfactory control of the winding pitch has been obtained so that with normal variations, the inductance of the coils is within the distribution requirements of the specification. This uniformity of winding is illustrated in the shadowgraph in Fig. 8, which is a typical example of current product. The type of machine modifications required to produce this improvement in product control included the following:



1. Eliminate slack in gear train by introduction of loaded gear drive.
2. Provide a constant force spring load on the worm drive so that the distributor exactly follows the cam motion.
3. Miniaturize wire guide assembly so that wire as placed on winding core will more closely follow the distributor motion.
4. Improve spindle bearings and distributor alignment.
5. Provide improved shut-off counter so that machine will give exact winding turns without overrun.

Although it might appear from the above discussion that winding coils on a controlled pitch basis will automatically result in the product having a normal distribution around a specified nominal inductance, the desired result can only be attained by continued vigilance, as many unpredictable variations will creep into the process from time to time. Gradual changes in control are readily observed from the charts, and in

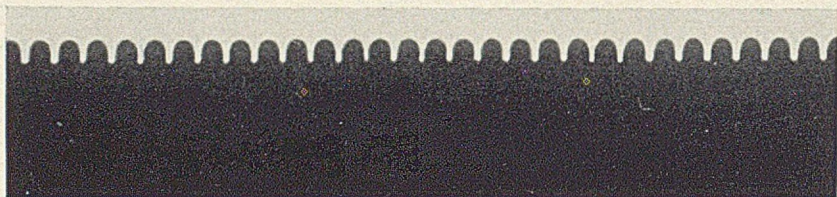

Fig. 8 — A shadowgraph of a coil winding showing uniformity of winding necessary to meet distribution requirements for inductance.

many cases, are enough indication to show need of replacement or repair of worn winding-machine members which control the winding pitch of the coil.

The 320-type retardation coil used in the cosine equalizer of the L3 system, requires all of the control vigilance of the splitting coil and, in addition, has introduced the necessity for even further winding precautions. Although this coil has the same per cent tolerance as some of the other coils manufactured under this specification, it is more difficult to control, since it has only about one-tenth as many turns in the winding as most of the other coils. The major inductance variations in this coil, therefore, are controlled by the variation in the end turn location and the winder checks the inductance by a continuous sampling of the product during the winding procedure. It is thus possible to promptly make necessary modifications in the location of the final turn to maintain the inductance distribution within requirements. Experience has shown that normal variations from operator to operator can run as high as  $\frac{1}{2}$  per cent on coils having a tolerance of 1 per cent, until the operator



becomes sufficiently skilled in the terminating methods. Thus, in order to obtain a product having normal distribution, close control of the winding operation must be maintained.

In addition to the above-mentioned single layer type coils, there is another general family of coils wherein distribution controls are useful during the initial period of development. The 1507 type, referred to as L-R inductors, are precise low-Q single-layer inductors wound with resistance wire on closely-controlled, low temperature-coefficient core tubes. These inductors are used in the input feedback network and as plate-feed inductors in the L3 amplifier, and are units which combine resistance and inductance in a single product. The stability of these coils is obtained by winding on a ceramic core form, similar to that used in the "splitting" coil, and using a low temperature-coefficient resistance wire in the winding. Simultaneous control of the resistance and inductance of this coil is obtained by the calibration of the winding machine setup to fit the resistivity of the wire used on the coil. Once the required turns and pitch have been determined for a given spool of wire, experience has shown that the resistance control will remain valid until the wire from the spool is exhausted.

The problem of making an accurate electrical measurement of a low Q inductor is a difficult one to resolve and it is here that an accurate control of testing methods by means of statistical analysis was employed. When an inductance ( $L_0$ ) and a resistance ( $R$ ) occur as series elements and the combination is shunted by the residual capacitance ( $C$ ) across the bridge terminals, the resulting measured inductance is equal to that of the original inductance minus the product of the capacitance and the square of the resistance.

$$\text{Measured inductance} = L_0 - CR^2$$

The above equation is generally true in the case of coils where the inductive reactance is small compared to the resistance. If standard test procedures were followed to make the measurement of inductance, using the familiar Maxwell Bridges,<sup>4</sup> an error would be introduced due to residual bridge and test jig capacitance. This would make the measured value considerably different from the coil inductance and would be dependent upon this residual capacitance and the coil resistance which could not be controlled with any degree of uniformity. Parallel resonating capacitance techniques are inadequate for the accuracies required, since the shunt equivalent of a very low-Q inductance is equal to that inductance divided by  $Q^2$ . Determination of inductance by this method, while better than the Maxwell Bridge method, is subject to errors due



to the inadequate readability of the capacitance standard of available test facilities.

Since the theoretical values of resistance and inductance are specified by design, the following methods of determining actual design parameters are used:

A. Determine mathematically, or by experiment, the number of turns of a given resistance wire wound on the core tube to produce the required resistance.

B. Wind high Q inductors using copper wire of the same diameter as the resistance wire and having the same number of turns as determined in Step A, varying the winding pitch to produce the required inductance.

C. Wind low Q inductors with the wire and number of turns of Step A and the pitch as determined in Step B.

D. Make Maxwell Bridge inductance measurements for the two groups of low and high Q inductors. The two sets of readings are then subjected to a statistical analysis to insure that the processes are in control so that the data may be used in selecting a nominal coil from the low Q group to use as a reference standard. While it is true that the apparent value of the resistance-wound inductors will be appreciably less than those of the copper wire variety, due to the  $CR^2$  correction, the nominal intrinsic inductances of the two groups of coils will be the same, due to their identical physical geometry.

Thus, by a method of comparison of two sets of readings, each of which is within process control, it is possible to select coils which can be used as reference standards. Any measurement which is made on a bridge set up from this reference standard will require correction of the inductance reading to compensate for the resistance variation. Self-compensating bridge methods have been developed which make it possible to read with good accuracy, directly on the bridge, the low Q coils covered by this family of inductors.

During the initial production of the 1507-type inductors, it was found expedient, for easier maintenance of control of the resistance and inductance variations, to use a nine-cell post-office method (three-cell by three-cell) which permits selection of product in any one of five ways using diametral axes, yet still maintaining the specification distribution covered by the three-cell method. The nine-cell method has gradually become less important, as experience has been gained with the use of the winding machines and control of winding operator variations.

Table III gives the over-all results of production of single-layer inductors and retardation coils, over a period of approximately one year. It can be seen that the design and production facilities are such that it is possible to manufacture a product within the requirements imposed by



TABLE III — YIELD OF COILS PRODUCED UNDER THE DISTRIBUTION REQUIREMENTS

Code	Nominal Values L—Microhenries R—Ohms	Tolerance Per cent ±	Total Production	Accumulated Un- packaged Product
AWA21 retard	L—191.61	1.0	514	90
AWA22 retard	L—166.2	2.0	342	6
302AW retard	L—1.58	10.0	545	0
302AY retard	L—3.70	5.0	410	47
302BA retard	L—1.425	1.3	702	140
302E retard	L—3.52	1.1	514	35
320F retard	L—26.11	1.7	702	130
320G retard	L—19.62	10.0	653	1
320M retard	L—1.428	1.0	307	53
320N retard	L—18.0	2.0	54	0
320P retard	L—0.874	1.0	10122	41
1500A inductor	L—43.53	1.0	1883	121
1500B inductor	L—40.44	1.0	738	12
1507A inductor	L—283.9	7.0	560	10
	R—260.8	7.0		
1507C inductor	L—78.2	4.0	685	71
	R—2025	2.0		
1507D inductor	L—6.5	2.0	881	230
	R—166.6	5.0		
1507E inductor	L—23.9	5.0	828	88
	R—1655	5.0		

NOTE: Production includes product manufactured which did not fall within the "A" Limits.

the distribution specification. In the case of the 302BA and 320F retards, the lower yield of these coils was found to be due to machine variations which have been corrected. In the case of the 1507D inductors, an additional limitation is caused by the lack of fine enough machine pitch control to permit proper manufacture of this coil. A new winding machine having adequate control is being provided to eliminate this condition.

It has become apparent, as production has progressed, that the manufacture of coils, such as are given in Table III, is going to remain a small lot business. Therefore, in all probability, the great majority of the production will be shipped by the three-cell method, with only a few cases of enough production to warrant the use of the Batch or Continuous methods where advantage can be taken of the sampling procedures.

### 3.3 APPLICATION TO CAPACITORS

#### 3.31 500-Type Molded Mica Capacitors

The 500-type molded mica capacitors have been one of the most difficult products to control within the requirements of the distribution



specification. This condition is inherent in the design and methods of manufacture of this type of product, as the process consists of an integrated group of manually-controlled operations. The following brief summary of these operations will give a better appreciation of the difficulties encountered in the control of a product of this type:

### 3.311 *Mica cut to size and silver coated*

- A. Inspected for visual and mechanical dimensional defects.
- B. Laminations silver coated by silk screen process and fired.

### 3.312 *Assembly*

A. Laminations stacked by count and interleaved with lead foil. In this state, the stack consists of laminations having multiple silvered areas.

B. Dip-sealed in Bi-Wax to hold pileup firmly together for subsequent operations and excess wax pressed out of pileup.

### 3.313 *Sectioning*

A. Section the multiple stack of laminations by punch and die to provide individual capacitor pileups.

### 3.314 *Preliminary stacking to capacitance range*

A. Rough adjust the individual capacitor pileups by adding or removing single laminations to meet a broad capacitance range which is capable of adjustment. Terminals are then attached by crimping.

### 3.315 *Adjusting*

A. Adjust by scraping silver from outer layer of mica until capacitance is within  $\pm 0.2$  mmf of specified value.

### 3.316 *Molding — Stabilizing*

- A. Mold in mica-filled molding compound.
- B. Stabilize by temperature cycling.

In a process of this type a number of individual operations combine to determine the final product capabilities. Control of distribution is difficult since many of these operations tend to substantially modify the distribution obtained in previous steps of the process. Figs. 9 and 10 show



the conditions encountered on two types of these capacitors which have different capacitance tolerances. Studies indicate that the percentage of the product falling within the cell limits at the present time will vary from 40 to 80 per cent depending on the capacitance value and tolerance. Thus an expected merchandise loss of 20 to 60 per cent falling outside of allowable tolerance exists which, in addition to the units classified but not eligible to ship due to poor distribution of product among cells, creates a condition resulting in increased cost of the product. It is expected, based on current methods and design, that the yield of the capacitors shipped within the requirements of the distribution specification will be between 20 and 70 per cent of the product manufactured. This represents a situation in which the specification tolerances, the product design, and the manufacturing process capabilities are not compatible, but because of the design needs it is still necessary to meet the distribution requirements. The use of the three-cell method makes this possible by the acceptance of relatively large shrinkages until improved manufacturing methods and materials now under investigation are introduced.

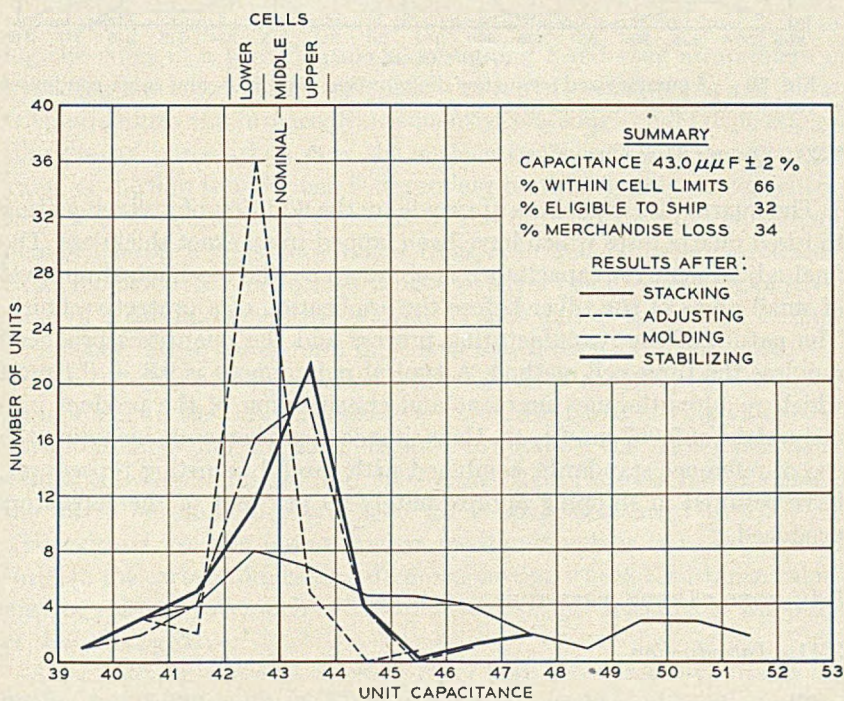

Fig. 9 — A summarized frequency distribution of a 43-mmf mica condenser at various stages of manufacture.



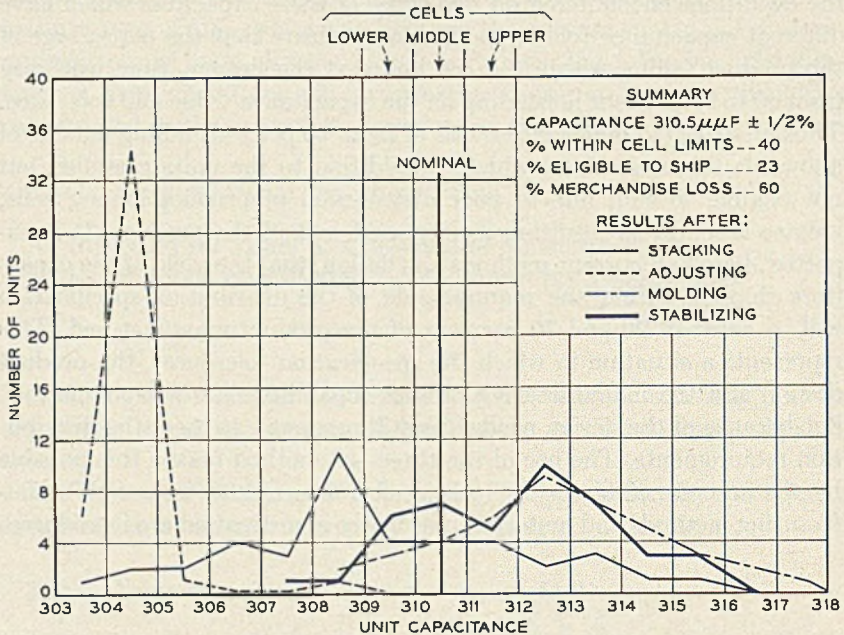

Fig. 10 — A summarized frequency distribution of a 310.5-nmf mica condenser at various stages of manufacture.

### 3.32 Quartz Disc Capacitors

The quartz disc capacitors are made by the addition of a silver coating to fused quartz discs which have been lapped to an exact thickness. The final adjustment for capacitance is obtained by the mechanical removal of small areas of the silver before the application of a protective finish. The nature of the manufacturing process and the quantities produced requires the three-cell method. A typical requirement is  $9.8 \pm 0.1$  mmf which requires the measurement and classification of the product into cell widths of 0.067 mmf each. Capacitance measurements, including the use of reference standards, combined with careful adjusting procedures, have resulted in shipping approximately 99 per cent of the capacitors produced.

## 3.4 BORO-CARBON RESISTORS

### 3.41 Introduction

The stringent requirements for L3 carrier line amplifiers and impedance matching and balancing networks prevented the use of commer-



cially available composition type resistors due to their high temperature coefficient and lack of stability. Fortunately a new unit, known as a boro-carbon resistor was under development and could be utilized. The boro-carbon films employed in this unit have a maximum temperature coefficient of resistance of 0.01 per cent per °C compared to ordinary deposited carbon films which may have an average temperature coefficient of 0.03 per cent per °C.

Two types of boro-carbon resistors covering approximately 45 resistance values are being produced for the L3 system. These types are the 200A resistors, held to a tolerance of  $\pm 3$  per cent and the 200B resistor held to a tolerance of  $\pm 1$  per cent. Both types are available in resistance values from 5 ohms to 9999 ohms inclusive. Of the 45 values used in L3 equipment, approximately 40 are of the 200A type and 5 are of the more precise 200B type.

### 3.42 *Manufacturing Procedure*

The core of the 200-type resistor consists of a high grade alkaline earth porcelain of special composition. The resistance film is produced by placing the cores in a heated furnace containing a reducing atmosphere of hydrogen and injecting a combination of a hydro-carbon gas and boron trichloride into the furnace. Subsequently, cracking occurs depositing a thin film of boro-carbon over the surfaces of the cores. The resistance value of the film thus formed is dependent on the relative gas concentrations and the duration of exposure in the furnace. By suitable control, blanks having a resistance range from 5 to 250 ohms are produced. After removal from the furnace a band of silver paste, consisting of silver flake in a suitable binder, is applied to each end of the coated ceramic and baked. These bands form the contact surfaces for the terminals.

The resistors are next sorted into resistance groups preparatory to adjustment to the desired resistance value. Resistors having values between 35 ohms and 50 ohms are used to produce the higher resistance values between 250 ohms and 9999 ohms. The resistors falling outside the 35 to 50 ohm range are held for simple adjustment by rubbing. The method used to obtain higher resistance values is to cut a helix through the carbon film using a diamond cutting wheel. Resistance values may be raised by as much as 1000 times by proper selection of the pitch of the spiral groove.

After helixing, these resistors together with those initially outside the 35 ohm to 50 ohm range are fitted with a lead assembly at each end. Final adjustment of the resistance value is obtained by abrading the entire



coated surface uniformly to reduce the coating thickness. An adjustment of 15 per cent increase may be obtained by this means. After adjustment, resistors are given a protective coating, code marked and subjected to ten accelerated aging cycles over a temperature range of  $-50^{\circ}\text{C}$  to  $85^{\circ}\text{C}$ .

### 3.43 *Use of Control Charts*

Since the manufacturing processes are essentially common within certain ranges of resistance it has been found possible to maintain control charts associated with the three-cell method for combinations of different values of resistance. In order to handle such combinations the characteristic under control is expressed as a percent deviation from the specified nominal. The control chart for averages then consists of averages of these percent deviations and the range chart is expressed in similar terms. This procedure permits a single chart to represent a large number of resistance values.

Control charts are used at two points in the manufacture of the 200-type resistors. The first chart is applied to the resistance value after adjustment either by rubbing, in the case of lower values, or by the combination of helixing and rubbing used for the higher resistance values.

Estimates based on preliminary studies predict that at half life this type of resistor will age upward by an average of 0.5 per cent. Manufacturing requirements for the nominal resistance values are set 0.5 per cent low in order to compensate for this condition.

The second chart is kept on the finished product after the accelerated aging cycles. This chart is also kept in terms of the percentage deviation from nominal. A comparison of the charts for the product after cycling, which represents the units which are candidates for stock, with those charts at the earlier resistance adjusting operation will show up changes in value due to processing. Appropriate changes in processing or adjustment bogies are made to obtain a more nearly centered value.

### 3.44 *Shipment of Product*

Although resistor production consists of a series of batch operations with each batch readily segregated and identified, the small quantities involved have resulted in the decision to package all of the product in accordance with the three-cell method.

The use of control charts after adjusting and after cycling has resulted in a more uniform product for the 200A resistors than would have been



possible by conventional manufacturing techniques. Initial production experience indicated that the "natural tolerance" of the 200A resistor is better than the  $\pm 4$  per cent "A" limit originally specified, and this limit was reduced to  $\pm 3$  per cent.

### 3.5 2504-TYPE TRANSFORMER

The 2504-type transformer, due to its critical function in the operation of the L3 amplifier circuit, has necessitated the use of completely new materials and methods not usually associated with transformer production. For instance the windings of this transformer are formed by diamond grinding the threads in fused quartz forms upon which a silver coating is bonded by a firing process. The grooves are then filled with electroplated copper, thus producing a winding intimately bonded to the quartz forms. Since the whole manufacturing process is unique and must be controlled in each small detail, application of statistical quality control procedures is essential.

Control of the leakage flux of this transformer, capacitance across the high impedance winding, and the capacitance to ground from the high potential terminal of its high impedance winding is of particular importance. To achieve the desired control of these characteristics, care must be taken to maintain a number of mechanical dimensions to tolerances far more precise than those on any transformer previously made by the Western Electric Company.

For example, the inner diameter of the quartz form, bearing the outer winding, is held to  $0.7280 \pm 0.0005$  inches, while the thickness of the form between the inner diameter and the root diameter of the threads is held to  $0.0310 \pm 0.0005$  inches. Dimensions of other component parts of the transformer must be held to comparable tolerances. To do this, it has been found necessary to keep all facilities — chemical, electrical and mechanical — under careful control at all times.

The facilities provided for the machining of the component parts are such that all critical dimensions which affect the final overall electrical characteristics of the transformer are held to approximately one-third of the design tolerances. By this means, it is expected the resulting transformers produced will meet the desired distribution. In the initial stages of production, records are being kept on 14 mechanical dimensions on each unit, checking them at each critical state of manufacture. The use of extensive mechanical tolerance controls on the components of this transformer is necessitated by the non-adjustable nature of its design. If controls were not applied, it would be impossible to obtain the close



electrical uniformity required by the end product. By means of special circuits and testing techniques developed for electrically measuring the characteristics of this transformer it has been found possible to indicate microscopic variations in secondary mechanical dimensions not directly under control.

The problem of bringing this transformer under control is not completely solved. Progress to date in the analysis of the data obtained indicates that the mechanical variations of the parts have complex inter-relations to the electrical requirements; however, manufacturing variations in the parasitic impedances mentioned above are being controlled to an order of magnitude better than on any transformer previously produced.

### 3.6 VACUUM TUBES

#### 3.61 *General*

Three new vacuum tubes, the 435A, 436A and 437A have been developed for use in the L3 amplifiers. These tubes were described in detail in an article appearing in *The Bell System Technical Journal* of October, 1951.<sup>5</sup> Two of them, the 435A and 436A are high transconductance tetrodes and the third tube, the 437A is a high transconductance triode. By applying the latest advances in design and in manufacturing techniques to tubes of conventional basic type, substantially higher levels of broadband amplifier performance have been realized.

The key to improvement in broadband amplification lies in an increase in figure of merit or transconductance to capacitance ratio. Figure of merit is a direct measure of the bandwidth over which the required level of amplification can be obtained. In general a given increase in figure of merit can be directly reflected in a wider transmission band which will provide more communication channels.

The higher transconductances and higher figures of merit obtained with the 435A, 436A and 437A over earlier broadband amplifying tubes are a direct result of advances in the art of manufacturing fine pitch grids of sufficient accuracy and rigidity to permit extremely close grid to cathode spacing. The basic objective is to provide a grid which can be placed very close to the cathode to act as a uniform potential plane controlling the cathode current without offering any physical obstruction to the passage of the current. This objective is approached by winding the grid with many turns of very small diameter wire.

The conventional method of grid manufacture consists of winding the grid lateral wire in a spiral around two side rods, usually of nickel. A groove is cut in the side rods at each point where the lateral crosses it



and the lateral is placed in this groove. The groove is closed by swaging to fix the lateral in place. In the L3 tubes, the grid lateral wire is approximately 0.0003" in diameter and the grid to cathode spacing is approximately 0.002". A ten per cent change in grid cathode spacing would result in a change in transconductance of fourteen per cent. It is important, therefore, that the control grid be maintained very accurately to insure proper grid to cathode spacing. A conventional grid made with such small diameter lateral wire would not be self-supporting in the length of span required and could not be made with the accurate control of diameter needed. Since the size of lateral wire used and the close spacing of adjacent turns preclude notching and swaging, some other method of holding the laterals in place must be employed. Accordingly, a new type of grid construction is used. This consists of making a supporting frame from two large side rods joined together by cross straps located at the ends of the grid proper. On this rigid frame the fine lateral wires are wound. This frame type of grid was described in previous articles.<sup>5, 6</sup> In the L3 grids, the lateral wires have been bonded to the support rods by a glass suspension sprayed along the edge of the support rods. This glass glaze is sintered at a temperature of approximately 700°C to hold the laterals firmly in place. The earlier design used a gold brazing operation to secure the laterals. This brazing was done at a temperature of approximately 1070° C. The newer method at the lower temperature produces less stretching of the laterals and as a result higher residual tension is obtained. This is a distinct advantage in reducing noise and the possibility of grid to cathode shorts.

With the new method of holding the laterals in place, the grids are gold plated after the glazing operation is completed. Gold plating is necessary in order to minimize thermionic emission from the grid wires due to the closeness of the grid to the hot cathode and the possibility that active cathode coating material may be deposited on the grid during processing and operation.

### 3.62 *Distribution Requirements*

Distribution requirements have been placed on transconductance as well as the most critical inter-electrode capacitances, the input capacitance,  $C_{g_1-k_{g_2}}$ , for the 435A and 436A tubes and the grid to plate capacitance,  $C_{g-p}$ , for the 437A. In the case of the 435A and 437A tubes, control of modulation is also required. Since transconductance is of primary importance, this characteristic has been selected as the one which governs shipment of product. Inter-electrode capacitance and modula-



TABLE IV — CHARACTERISTICS OF VACUUM TUBES STUDIED

435A and 436A	437A
Cathode current ( $I_k$ )	Plate current ( $I_b$ )
Grid-plate capacitance ( $C_{g_1-p}$ )	Plate resistance ( $R_p$ )
Plate-cathode, screen grid cap. ( $C_{p-kg_1}$ )	Heater-cathode cap. ( $C_{h-k}$ )
Grid-heater cap. ( $C_{g_1-h}$ )	Heater-grid cap. ( $C_{h-g}$ )
Heater-cathode, screen grid cap. ( $C_{h-kg_2}$ )	Heater-plate cap. ( $C_{h-p}$ )
Heater-plate cap. ( $C_{h-p}$ )	Grid-cathode cap. ( $C_{g-k}$ )
	Plate-cathode cap. ( $C_{p-k}$ )

tion are subject to the requirements of the Records method previously described.

In addition to the characteristics mentioned above, control charts were maintained on a number of other electrical characteristics at final test in order to determine process capabilities and to aid in setting final test specification limits. Among the characteristics that were studied were those given in Table IV. It was recognized at the beginning of production of these vacuum tubes that control of the test characteristics could not be achieved without similar control of the critical piece parts and processes going into the assembly of the tubes. Accordingly, control charts were started on the parts and processes, given in Table V, and have been maintained throughout the manufacture of the product.

Production of vacuum tubes represents a complex interlinking of many separate processes, each of which is essentially a batch type of manufacture. These batches vary considerably in size depending on the process or part involved. No part or process can usually be singled out as the controlling effect which would isolate one group of tubes from another. For example, a given lot of 100 tubes would probably be made from cathode blanks taken from a supplier's production run of 5 to 10 thousand parts. The cathode coating would be applied in batches of 50 to 200 parts. The control grid side rods used in making the grid frames would have come from a production run of perhaps 5000 parts and the

TABLE V — PARTS AND PROCESSES ON WHICH CONTROLS CHARTS WERE USED

Cathode blank	Outside diameter
Coated cathode	Outside diameter
Control grid support rod	Outside diameter
Control grid wire diameter	Unplated
Gold thickness	Control grid wire
Control grid	Minimum lateral resonance frequency
Screen grid	Minor axis, outside diameter
Plate	Inside diameter



fine grid wire used in winding the grid might be from a lot of 300 to 1000 meters etched to size at one time. The mounts are generally sealed into their glass envelopes in lots of 50 to 200 and pumped in lots of approximately 50 tubes.

Since the individual batches of parts and processing lots are of such different sizes, the final product does not result in groups of tubes that can be readily segregated into distinctive lots. As the tubes are assembled on a regular running basis the production is treated as being of a continuous nature and the Continuous Production method is applied. Mounts made from each week's production are identified by a serial number and, at test, samples from each week's production are used in determining conformance to the requirements of the distribution specification.

In the application of control charts to the L3 carrier vacuum tubes, the charts kept on the characteristics required by the test specification have been plotted against the *C*, *D* and *E* limits derived from the specifications. The charts kept on the parts and on other test characteristics have control limits derived from the process capabilities. In some cases these natural limits have been compatible with the original drawing limits and in others they have been at variance. Wherever incompatibility was established, an attempt was made to improve the process or where correlation studies justified the action, agreement was reached with the design engineers to increase the drawing tolerances.

### 3.63 *Application of Control Charts*

#### 3.631 *Cathodes*

The cathodes used in the 435A, 436A and 437A are purchased from an outside supplier. A maximum variation from nominal of  $\pm 0.0002''$  was specified for the minor axis outside diameter. These limits are tighter than for any previous similar cathode used, the narrowest limits heretofore being  $\pm 0.0005''$ . A control chart established on the first lot of cathodes produced for the 436A and 437A tubes indicated that a standard deviation ( $\sigma$ ) of  $0.00021''$  was obtainable. The 3-sigma limits thus derived of  $\pm 0.00063''$  in addition to the displacement in the average ( $\bar{X}$ ) for the lot of  $+0.00026''$  represented a completely unsatisfactory condition. By selection of cathode blanks the nominal was reduced to  $0.03121''$ , approximately equivalent to the maximum permitted by the drawing. A much narrower range resulted from this selection. The standard deviation for selected cathodes amounted to  $0.000066''$  corresponding to 3-sigma limits of  $\pm 0.00020''$ . However, this distorted distribution



was still unsatisfactory and attempts were made to obtain cathodes more nearly conforming to the design requirements. In the meantime a sizing operation was introduced in the shop to adjust the existing cathodes to size. By the additional sizing operation, the nominal value was reduced to 0.03102" almost exactly the desired value. However, the standard deviation of 0.00014" and 3-sigma spread of  $\pm 0.00042$ " were still twice the design intent.

A second run of cathodes was obtained in which the average measured 0.03099" and the 3-sigma limits were  $\pm 0.00021$ ". This substantially fulfilled the design requirements but made it imperative that the average be held precisely at nominal. To avoid differences between measuring instruments an agreement was reached to use a common type of electronic micrometer at both the suppliers' plant and the Western Electric Company. Control charts are kept by the supplier using a modification of the Continuous Production method outlined in the distribution specification. The application of this procedure has resulted in maintaining close control of the averages. Correlation studies on tubes manufactured with these cathodes, have shown that the limits for individual cathodes could be expanded to  $\pm 0.00033$ ".

### 3.632 *Coated Cathodes*

Three characteristics of oxide coated cathodes are particularly important in producing adequate emissive qualities, satisfactory life and the close spacing required in the L3 carrier tubes. These characteristics are weight of coating, density and coated dimensions particularly length and minor axis. In order to eliminate cathode blank variations from the measurements, dummy cathodes of known weight and precise diameter are included with each spray rack load of 41 cathodes. Measurements of gain in weight and of the increase in diameter due to coating are made on these dummy cathodes. The density can be calculated from these measurements. In addition to the measurements made on the dummy cathodes, control charts are kept on coated length and coated diameter on sample cathodes from each coating lot.

### 3.633 *Control Grid*

Close control of the minor axis for the frame type of control grid used in all three tube types is obtained by precision manufacture of the molybdenum side rods used in making the grid frame. The design specifications require a tolerance of  $\pm 0.0001$ " on the diameter of these rods. Adjustment of this diameter is obtained by tumbling the parts, which rounds



the ends of the rods at the same time to permit easy insertion of the grid in the support micas. Initial production was measured with a barrel micrometer read to the nearest 0.0001". The resulting data indicated a standard deviation of 0.00013". The 3-sigma limits of  $\pm 0.00039''$  were four times the desired spread. Some portion of this spread was undoubtedly due to the measuring instrument which could not be read with sufficient precision. Subsequent production was measured with a Brown and Sharpe dial indicating barrel micrometer which was calibrated with standard gage blocks. Production measured under these conditions indicated the standard deviation to be 0.00007" for process limits of  $\pm 0.0002''$ . Fortunately, correlation studies indicated this tolerance to be acceptable. Control charts are kept on the product after the tumbling operation. The desired average is maintained by sampling the side rods for diameter several times during the tumbling operation.

The lateral wire used in winding the control grid is tungsten, etched to a diameter of  $0.00029'' \pm 0.00001''$ . The diameter of the wire is measured with a Bausch and Lomb metallurgical microscope equipped with a Filar eyepiece. The magnification used is approximately 450X. During initial production, it was not certain that wire of this size could be obtained consistently to a given nominal value and a chart was prepared adjusting the specified winding turns per inch to accommodate wire sizes from 0.00027" to 0.00032".

Control charts kept on the wire diameter have shown that it is possible to make wire consistently to a diameter of  $0.00029 \pm 0.00001''$ . Correlation studies have been made comparing grids of various wire sizes and corresponding turns per inch against the related tube characteristics. From these studies it was determined that with wire controlled to  $0.00029'' \pm 0.00001''$ , a single winding pitch for each tube could be substituted for the chart of turns per inch originally used. Subsequently, studies were made which enabled a common grid to be used in the 436A and 437A tubes.

After winding, the grids are gold plated. The desired increase in lateral wire diameter as a result of plating is 20 micro inches with limits of  $\pm 10$  micro inches. This measurement is also made with the microscope equipped with a Filar eyepiece.

Considerable difficulty has been encountered with measurement of wire diameter. Variations between operators have been encountered as well as differences between successive readings made at the same point on the wire. This difficulty has been minimized by careful training of the operators and by taking several readings at each point and averaging them.



The difficulties with instrumentation encountered with measurements of gold plating thickness make it more difficult to establish the standard deviation of the process. By determining the standard deviation of the measuring method used, it appears that a value of 4 to 5 micro inches may be realized. This corresponds to 3-sigma limits of 12 to 15 micro inches. Fortunately, correlation studies have established that this control has resulted in tube characteristics which have more than met the test requirement.

### 3.634 *Screen Grids*

The screen grids used in the 435A and 436A tubes are of conventional design. The tolerance for minor axis diameter is  $\pm 0.001''$ . The grids are first wound in strips on a mandrel which is shaped to the approximate dimensions of the desired finished grid. The strips are next degreased and given a preliminary heat treatment at  $700^{\circ}\text{C}$  for 5 minutes and then stretched longitudinally to straighten the side rods. The strips are then cut into individual grids and the loose grid lateral turns are trimmed from the ends. A heat treatment at  $925^{\circ}\text{C}$  for 15 minutes follows and finally the grids are sized, which consists of stretching the major axis on an expanding set of sizing blades to obtain the desired shape and size.

It was felt that it would be difficult to control the minor axis around a desired nominal since so many operations took place between the winding of the grid and the final sizing operation. Corrections for deviation of the center of the distribution usually consisted of slight changes in the amount of stretch imparted at the sizing operation and major corrections were usually attempted by a change in winding location on the tapered winding mandrel.

Process capability studies revealed a parent distribution of approximately  $\pm 0.001''$  which is within the specified tolerance but provides no allowance for shift in average from one lot to another. Successive lots of grids processed in the same manner showed a considerable shift in center of distribution, amounting to as much as  $\pm 0.0007''$ .

Studies were then made to determine the important variables which needed to be controlled in order to minimize the shift in average value. It was found that for a given spool of grid wire, considerable control of the process average could be obtained by careful attention to two points in the processing. The grid minor axis size varied directly as the tension of the lateral wire was increased at the winding operation. By variation in tension, as much as  $0.0005''$  shift in process average could be obtained. Secondly, when a more precisely controlled heat treating oven was used



which employed a thermocouple in each heat treating boat, it was established that the final minor axis dimension varied inversely with the heat treating temperature. Temperatures between 850° C and 1000° C could be used satisfactorily with a corresponding shift in process average of 0.0006". In Fig. 11(a) is shown the variation of grid minor axis with temperature and in Fig. 11(b) the variation of size with tension is indicated.

A procedure was then set up which resulted in a more uniform grid production. Each time a new spool of wire is used, a group of 25 grids is wound using a standard value of tension. These grids are processed through final sizing using 925° C for heat treatment and the standard sizing blades. The distribution of these 25 grids is then plotted. The position of the average is noted and correction is made for displacement of the average by a change in winding tension, a change in heat treating

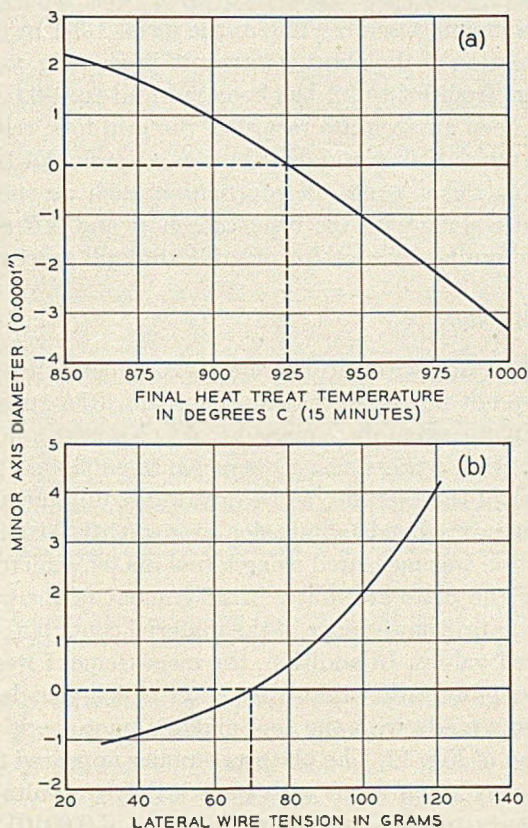

Fig. 11 — Control of grid minor axis in terms of temperature and tension.



temperature or a combination of both. Homogeneous lots of grids, are next run from this spool of wire and are processed up to the sizing operation using the same standard conditions. This test lot of 25 grids is run whenever a new spool of wire is introduced.

The first few grids from each lot are sized on the standard sizing blades and checked against a reset-run chart,<sup>7</sup> a form of sequential analysis. The set-up is satisfactory if the distribution of the minor axis dimension is found to be within 1-sigma ( $0.0003''$ ) of nominal. If grids pass the reset-run chart the balance of the lot is sized on the standard blades. If the sample does not conform to the reset-run chart, a final correction is made by substituting a larger or smaller set of sizing blades as required.

The distribution of the minor axis after sizing is plotted on control charts. A sample of 5 grids is taken from each tray of 36 grids and  $\bar{X}$  and  $R$  plotted. If in control the lot is passed. If out of control, the lot is 100% inspected and packaged into three cells. The grids are then shipped to the mount assembly line in the usual 1-3-1 or 0-5-0 distribution. By application of the above controls of processing, variation in the process average from lot to lot has been reduced to  $\pm 0.0003''$ .

In order to keep an accurate record of the grid lots, relating the processes used to the resulting grid distribution, a special lot ticket has been developed. This ticket contains information such as specified tension and temperature along with the reset-run chart and  $\bar{X}R$  chart. A ticket of this type accompanies each lot of grids through processing.

### 3.635 *437A Plate*

Since the 435A and 436A are tetrodes, the dimensions of the plate in these tubes are not nearly so critical as for the 437A tube, a triode. In the 437A, the plate assembly is made up of two sections welded together on a mandrel. An air press sizing operation is employed to control the inside diameter of the assembly. The drawing requirement for the plate assembly minor axis inside dimension was set at  $0.0750 \pm 0.0005''$ . Initial production was measured using a tool maker's microscope sighted on the edge of the plate assembly. Misalignment of the part under the microscope and burrs on the edge of the material contributed to variation in the measured values. In addition, the measurement was made at the edge of the assembly rather than the center which was desired. Results of measurements made with the tool maker's microscope are shown on the first portion of Fig. 12. The plate assemblies appeared to be oversize, although this was at variance with electrical test results on the tubes made from these parts. The standard deviation of  $0.00101''$  and 3-sigma limits of  $0.00303''$  were entirely too wide to meet the design intent.



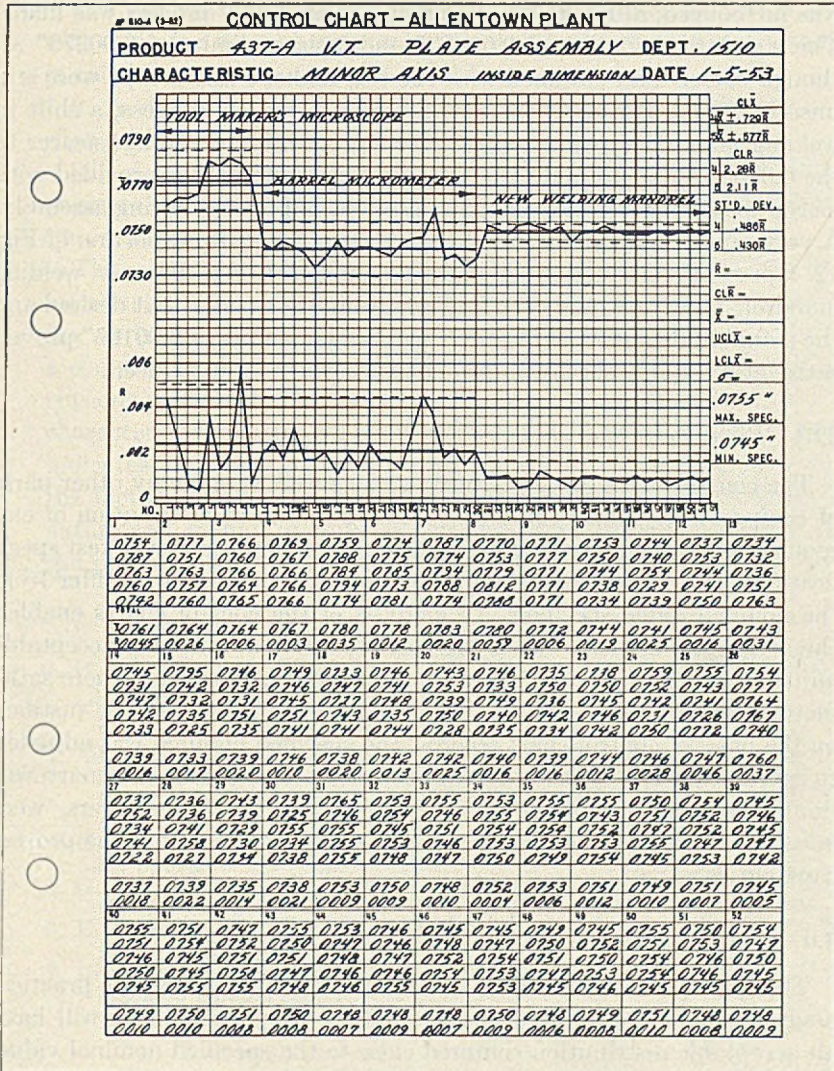

Fig. 12 — A control chart showing the results of using different methods of measuring the minor axis of plate assembly of the 437A vacuum tube.

A change was introduced in measuring technique at this point. The plate assemblies were measured at the center with a barrel micrometer. The thickness of the material was determined for each sample and subtracted to obtain the inside dimension. The point at which the new measuring method was introduced is indicated on Fig. 12. It will be noted that the average value shifted downward when the change in measuring



was introduced, although no change in the assembly process was made. The standard deviation of 0.00090" and 3-sigma limits of 0.00270" although better than obtained with the tool maker's microscope were still unsatisfactory. Based on the new average  $\bar{X}$  for the process, a shift in welding mandrel was made directed at producing an average nearer to the 0.0750" value desired. The new welding mandrel was provided with heavy spring clips to hold the plate sections in position during assembly. A very uniform product resulted from this tool. The third portion of Fig. 12 represents production of plate assemblies using the new welding mandrel. The average  $\bar{X}$  of 0.07495" was almost exactly that desired and the standard deviation of 0.00035" and 3-sigma limits of 0.00106" proved satisfactory and a change in the specification was introduced.

### 3.64 *Final Test Characteristics*

The controls kept on the critical parts as well as on many other parts of comparatively lesser importance have resulted in distribution of end requirements that have been well within the tolerances in the test specifications. In several cases the process average was found to differ from the nominal value specified. An analysis of the control charts enabled the design and manufacturing engineers to arrive at mutually acceptable adjustments of either the process or the test specifications. Where satisfactory performance would be obtained and the shift could be justified on the basis of control chart records, the specified nominal was adjusted to conform with the process average obtained. At the same time narrower limits, assuring a more uniform product to the L3 amplifiers, were adopted wherever it became evident that these were within the process capabilities.

## 4.0 CONCLUSIONS

The quality control methods described in this paper provide practical assurance that the selected characteristic of any component will have an acceptable distribution centered close to the specified nominal value. In this application, various statistical quality control techniques are an actual part of the product specification. The additional effort required in the application of such procedures is compensated for in part by the valuable assistance they provide in controlling the manufacture of the product. The procedures provide:

1. Means for determining compatibility of the product specification and the manufacturing process capabilities including the accuracy and stability of measuring facilities.



2. Useful techniques for improving manufacturing processes and for indicating the need of replacement or repair of worn tools and machines in the factory.

3. A device for promptly focusing attention on deviations due to changes in raw material or components.

All of these items are useful to both the design and manufacturing engineer in evaluating the relationship between the product design and the manufacturing and testing facilities.

The relatively small number of L3 amplifiers produced to date and the introduction of product design changes and modifications in manufacturing methods, which are inevitable during the early production period of a complex product of this nature, make it impossible to form final conclusions relative to the correlation between the distributions of related characteristics of the components and the final amplifier. Experience indicates, however, that these methods are of considerable assistance to the factory during the introduction of new designs of products of this nature and should, in addition, become a permanent and useful part of the production of products having such critical requirements.

## 5.0 REFERENCES

1. H. F. Dodge, B. J. Kinsburg and M. K. Kruger, The L3 Coaxial System — Quality Control Requirements, see pp. 943 to 968 of this issue.
2. W. A. Shewhart, *Economic Control of Quality of Manufactured Product*, D. Van Nostrand Co., Inc., New York, N. Y. (1931).
3. ASA War Standards Z1.1 — 1941, Guide for Quality Control; Z1.2 — 1941, Control Chart Method for Analyzing Data; and Z1.3 — 1942, Control Chart Method for Controlling Quality During Production. American Standards Association, New York, N. Y.
4. H. T. Wilhelm, Impedance Bridges for the Megacycle Range, *Bell Sys. Tech. Jr.* **31**, pp. 999 to 1012, Sept., 1952.
5. G. T. Ford and E. J. Walsh, The Development of Electron Tubes for a New Coaxial Transmission System, *Bell Sys. Tech. J.*, **30**, 1103 to 1128, Oct., 1951.
6. E. J. Walsh, Fine-Wire Type Vacuum Tube Grid, *Bell Lab. Record*, **28**, pp. 165-167, April, 1950.
7. Dorian Shainin, Quality Control Methods — Their Use in Design — Part III, *Machine Design*, Sept., 1952.



Faint, illegible text, possibly bleed-through from the reverse side of the page. The text is too light to transcribe accurately.



# Abstracts of Bell System Technical Papers\* Not Published in this Journal

AHEARN, A. J.,<sup>1</sup> AND H. B. HANNAY<sup>1</sup>

**Formative of Negative Ions of Sulfur Hexafluoride**, *J. Chem. Phys.*, **21**, pp. 119-124, Jan., 1953.

Negative ion production in SF<sub>6</sub> has been studied in a mass spectrometer; SF<sub>6</sub><sup>-</sup>, SF<sub>5</sub><sup>-</sup>, SF<sub>4</sub><sup>-</sup>, F<sup>-</sup> were identified. The SF<sub>6</sub><sup>-</sup> and SF<sub>5</sub><sup>-</sup> are produced in very large quantities by a resonance capture process at an electron energy of about 2 ev, and are formed in approximately equal amounts. At higher electron energies, the same capture occurs by a secondary process, in which low energy electrons released by other excitation and ionization processes suffer the resonance capture. Partial dissociation after electron capture accounts for the appearance of F<sup>-</sup> and F<sub>2</sub><sup>-</sup> ions below 16 ev. Above this energy, other processes will also produce these ions. Possible explanations of the primary resonance capture mechanism are discussed.

ANDERSON, F. B.<sup>1</sup>

**Gain and Phase Angle Measuring Set**, *Elec. Eng.*, **72**, pp. 245, Mar., 1953.

Digest of paper "A 10-Cycle to 10-Megacycle Gain and Phase Angle Measuring set."

ARMSTRONG, C. A.<sup>2</sup>

**Communications for Civil Defense**, *Elec. Eng.*, **72**, pp. 218-222, Mar., 1953.

BECK, A. C., see S. E. MILLER.

---

\* Certain of these papers are available as Bell System Monographs and may be obtained on request to the Publication Department, Bell Telephone Laboratories, Inc., 463 West Street, New York 14, N. Y. For papers available in this form, the monograph number is given in parentheses following the date of publication, and this number should be given in all requests.

<sup>1</sup> Bell Telephone Laboratories, Inc.

<sup>2</sup> American Telephone and Telegraph Company.



BECKER, J. A.,<sup>1</sup> AND C. D. HARTMAN<sup>1</sup>

**Field Emission Microscope and Flash Filament Techniques for the Study of Structure and Adsorption on Metal Surfaces**, *J. Phys. Chem.*, **57**, pp. 153-159, Feb., 1953 (Monograph 2073).

With field emission electron microscopes one can see the structure of the surface of a single crystal at the tip of a metal "point." The magnification is about  $10^6$  and the resolution about  $20 \times 10^{-8}$  cm. At  $2800^\circ\text{K}$ , the surface of *W* point is hemispherical. Only the 110, 111 and 100 regions consist of small flat planes. In fields of 50 million volts/cm. and  $1200^\circ\text{K}$ . these planes enlarge. The edges of the planes are seen to be in violent agitation. Hence surface atoms are mobile at temperatures above one-third of the melting point. Ba atoms show surface mobility at  $400^\circ\text{K}$ . on the 110 and at  $800^\circ\text{K}$ . on the 100 planes. With the flash filament technique one can measure the rate at which  $N_2$  is adsorbed on a *W* ribbon at low pressures. After  $N_2$  has been absorbed for minutes at a low temperature, the ribbon is flashed at  $2300^\circ\text{K}$ . The sudden rise of pressure is recorded with an ion gage and measures  $\theta$ , the layers adsorbed. From a family of  $\theta$  versus time curves one calculates *s*, the sticking probability. For  $T = 300^\circ\text{K}$ .,  $s = 0.55$  from  $\theta = 0$  to 1.0. Then *s* decreases from 0.55 to about  $4 \times 10^{-4}$  for  $\theta = 2.0$ . These data yield an activation energy for the conversion of a molecule to two adatoms of about 100 cal./g. mole for  $\theta = 0$  to 1.0 and 5000 cal./g. mole at  $\theta = 2.0$ . Other experiments yield 100,000 cal./g. mole for the heat of adsorption of 2 adatoms. The heat of adsorption of molecules is much smaller.

BOZORTH, R. M.,<sup>1</sup> AND R. W. HAMMING<sup>1</sup>

**Measurement of Magnetostriction in Single Crystals**, *Phys. Rev.*, **89**, pp. 865-869, Feb. 15, 1953 (Monograph 2074).

A simplified procedure is given for determining the five magnetostriction constants of a single crystal of a ferromagnetic cubic crystal. The crystal is cut as a disk parallel to a (110) plane, and strain gauges are cemented to the surfaces to measure strains in (001) and (111) directions. A magnetic field sufficient for saturation is oriented in  $10^\circ$  steps at various angles to the (001) direction, and magnetostriction is measured over a  $90^\circ$  range for each gauge. Each of the 18 data is then multiplied by suitable numbers, obtained by inversion of the strain matrix, to give the constants  $h_1 \dots h_5$ . The method is applied to a crystal of a 78 per cent nickel-iron alloy to determine the magnetostriction associated with spontaneous magnetization in the (111) direction:  $\lambda_{111} = 2h_2/3 + 2h_5/9$ , a quantity important in the "Permalloy problem." The constants are also determined for a single crystal of nickel.

BOZORTH, R. M.,<sup>1</sup> AND J. G. WALKER<sup>1</sup>

**Magnetic Crystal Anisotropy and Magnetostriction of Iron-Nickel Alloys**, *Phys. Rev.*, **89**, pp. 624-628, Feb. 1, 1953 (Monograph 2076).

<sup>1</sup> Bell Telephone Laboratories, Inc.



Single crystals of a number of iron-nickel alloys were prepared, and measurements made of the magnetic crystal anisotropy, and of the magnetostriction at saturation in different crystallographic directions, as dependent on the rate of cooling of the specimens after annealing. There is a large effect of the cooling rate on the anisotropy, for compositions near  $\text{FeNi}_3$ , where atomic ordering occurs. There is a definite but smaller effect of cooling rate on the magnetostriction. The composition for highest initial and maximum permeabilities is nearly that for which  $\lambda_{111}$ , the magnetostriction in the direction of easy magnetization, is equal to zero.

DALTON, A. G.<sup>3</sup>

**Practice of Quality Control**, *Sci. Am.*, **188**, pp. 29-33, Mar., 1953.

Statistical analysis of manufacturing processes has become a powerful tool of technology. An account of how its principles are now applied in the factory.

DRVOSTEP, J. J.,<sup>1</sup> AND A. W. LEBERT<sup>1</sup>

**Standardization of Rigid Coaxial Transmission Lines**, *Tele-Tech*, **12**, pp. 78-79, Feb., 1953 (Monograph 2077).

DEHN, J. W., see R. W. Burns.

FELKER, J. H.<sup>1</sup>

**Arithmetic Processes for Digital Computers**, *Electronics*, **26**, pp. 150-155, Mar., 1953 (Monograph 2078).

Special codes and arithmetical processes enable digital computers to perform rapidly many heretofore laborious mathematical tasks. Review of these processes serves as introduction to newcomers to field and review for veteran computer engineers.

GOUCHER, F. S.,<sup>1</sup> AND M. B. PRINCE<sup>1</sup>

**Interpretation of  $\alpha$ -values in  $p$ - $n$  Junction Transistors**, *Phys. Rev.*, **89**, pp. 651-653, Feb. 1, 1953 (Monograph 2068).

By the measurement of five parameters in several  $p$ - $n$  junction transistors, viz., the conductivities and diffusion lengths of minority carriers in the emitter and base regions and the widths of the base regions, the current amplification factor  $\alpha$  of the transistors has been computed from theory. Previous to this investigation two of the parameters associated with the thin  $p$ -layer had not been measured. The quantity  $\alpha$  also was obtained independently by two alternate methods: (1) by measuring the collector-emitter current characteristic, and (2) by measuring the apparent quantum efficiency of the transistor as a two-electrode photocell with a floating base. The three determined values of  $\alpha$  for each sample agree within the experimental error.

<sup>1</sup> Bell Telephone Laboratories, Inc.

<sup>3</sup> Western Electric Company.



HAMMING, R. W., see R. M. Bozorth.

HANNAY, N. B., see A. J. Ahearn.

HARTMAN, C. D., see J. A. Becker.

HEWITT, W. P., see W. P. Mason.

HULM, J. K., see B. T. Matthias.

JONES, H. L.<sup>4</sup>

Approximating the Mode From Weighted Sample Values, *Am. Stat. Assoc., J.*, **48**, pp. 113-127, Mar., 1953.

The weighted mean of ordered sample observations can be used to approximate the mode under favorable conditions, where the weights are determined from the first two terms in a Taylor expansion of the maximum likelihood estimate. Such weights are shown in Table 1 for the case where the sample is selected from a *t*-distribution with known kurtosis.

LEBERT, A. W., see J. J. Drvostep.

LEWIS, H. W.<sup>1</sup>

Calibration of the Rolling Ball Viscometer, *Anal. Chem.*, **25**, pp. 507-508, Mar., 1953.

MASON, W. P.,<sup>1</sup> W. H. HEWITT<sup>1</sup> AND R. F. WICK<sup>1</sup>

Hall Effect Modulators and "Gyrators" Employing Magnetic Field Independent Orientations in Germanium, *J. Appl. Phys.*, **24**, pp. 166-175, Feb., 1953 (Monograph 2079).

Three uses for the Hall effect in germanium crystals are described. These are (1) use of Hall effect probes in measuring magnetic flux, (2) use of Hall effect in crystals to produce a pure product modulator, and (3) use of Hall effect in germanium crystals to produce a nonreciprocal transmission. If the resistances are shunted around such gyrators, the transmission can be made zero in one direction and finite in the other. In all these applications, use is made of a crystal orientation for which the cross magneto-resistance effects are zero and the Hall effect constant does not vary with field by more than 2 per cent out to a flux density of 20,000 gauss. This orientation was located by making a phenomenological study of the magneto-resistance and Hall effect corrections for a cubic crystal and evaluating constants experimentally. Correction terms to fourth and fifth powers of the magnetic field have been obtained.

<sup>1</sup> Bell Telephone Laboratories, Inc.

<sup>4</sup> Illinois Bell Telephone Company.



MATTHIAS, B. T.,<sup>1</sup> AND J. K. Hulm<sup>1</sup>

**Superconducting Properties of Cobalt Disilicide**, Phys. Rev., **89**, pp. 439-441, Jan. 15, 1953.

A solid rod of cobalt disilicide was found to have a superconducting transition temperature close to 1.4°K, a critical field gradient of 146 gauss per degree at the transition point, an ice-point resistivity of 16.5 micro-ohm cm and a residual resistivity of about 16 per cent of the ice-point value.

MILLER, R. L.<sup>1</sup>

**Auditory Tests with Synthetic Vowels**, J. Acoust. Soc. Am., **25**, pp. 114-121, Jan., 1953.

The results are given for a series of phonetic evaluation tests which were made by means of synthetically produced vowel sounds. By employing synthetically produced sounds, a number of the significant parameters could be varied in an independent and systematic manner without encountering the uncertainties and limitations of the human speech mechanism. The types of parameter changes which were investigated by this means were those of fundamental frequency or pitch, formant frequency and amplitude, and, finally, the number of formants important to a sound. The results of the tests indicate that all of these parameters are important in the evaluation of the sound. In particular, there is a shift in the phonetic evaluation which can be attributed to pitch alone.

MILLER, S. E.,<sup>1</sup> AND A. C. BECK<sup>1</sup>

**Low-Loss Waveguide Transmission**, I.R.E., Proc., **41**, pp. 348-358 Mar., 1953 (Monograph 2080).

The circular electric mode in round metallic tubing becomes increasingly more attractive than the dominant mode from the standpoint of minimizing the waveguide size at frequencies above about 10,000 mc for the loss criterion of 0.25 db/100 feet. The circular electric (TE<sub>01</sub>) mode also makes available a theoretical heat loss of 2 db/mile in waveguides less than 6 inches in diameter at frequencies higher than about 5500 mc. Increased transmission bandwidth, reduced delay distortion, and reduced waveguide size are factors favoring use of the highest practical frequency of operation. An increased number of freely propagating modes and smaller mechanical tolerances are the associated penalties. Experimental work has been carried out in the 9000-mc region using the TE<sub>01</sub> mode in a pipe about 5 inches in diameter. Transmission of 0.1- $\mu$  sec pulses had been observed over a distance of 40 miles. Mode conversion and surface roughness of the tubing walls result in observed losses which average about 50 per cent higher than the theoretical values for geometrically perfect, smooth-walled tubing. There is included a brief discussion of several problems unique to transmission in a multimode medium, including pure mode generation, mode filtering, the bend problem, and the effects of mode conversion on transmission loss and signal fidelity.

<sup>1</sup> Bell Telephone Laboratories, Inc.



NYE, J. F.<sup>1</sup>

Some Geometrical Relations in Dislocated Crystals, *Acta Metallurgica*, **1**, pp. 153-162, Mar., 1953.

When a single crystal deforms by glide which is unevenly distributed over the glide surfaces the lattice becomes curved. The constant feature of distortion by glide on a single set of planes is that the orthogonal trajectories of the deformed glide planes (the *c*-axes in hexagonal metals) are straight lines. This leads to the conclusion that in polygonisation experiments on single hexagonal metal crystals the polygon walls are planes, while the glide planes are deformed into cylinders whose sections are the involutes of a single curve. The analysis explains West's observation that *c*-axes in bent crystals of corundum are straight lines. For double glide on two orthogonal sets of planes there is a complete analogy between the geometrical properties of the distorted glide planes and those of the "slip-lines" in the mathematical theory of plasticity. More general cases are discussed and formulae are derived connecting the density of dislocations with the lattice curvatures. For a three-dimensional network of dislocations the "state of dislocation" of a region is shown to be specified by a second-rank tensor, which has properties like those of a stress tensor except that it is not symmetrical.

O'CONNOR, S. F.<sup>3</sup>

Plating Room Waste Water Disposal, *Metal Finishing*, **51**, pp. 56-58, Feb., 1953.

OLSEN, K. M., see W. G. Pfann.

OWENS, C. D.<sup>1</sup>

Analysis of Measurements on Magnetic Ferrites, *I.R.E., Proc.*, **41**, pp. 359-365, Mar., 1953 (Monograph 2075).

The unconventional behavior of permeability and core loss in the magnetic ferrites as compared to metals has led to a study of core-loss measurements. The relationships between the magnetic quality factor  $\mu Q$  and the characteristics of coils and transformers are developed, and the advantages of  $\mu Q$  as a parameter for the study and application of ferrites are discussed. A selected bibliography is given.

PFANN, W. G.,<sup>1</sup> AND K. M. OLSEN<sup>1</sup>

Purification and Prevention of Segregation in Single Crystals of Germanium, *Letter to the Editor, Phys. Rev.*, **89**, pp. 322-323, Jan. 1, 1953.

<sup>1</sup> Bell Telephone Laboratories, Inc.

<sup>3</sup> Western Electric Company.



PRINCE, M. B., see F. S. Goucher.

QUARLES, D. A.<sup>5</sup>

A.I.E.E. Progress, Elec. Eng., **72**, pp. 189-191, Mar., 1953.

In his address before the A.I.E.E. Winter General Meeting, President Quarles reviews some matters of current interest to the engineering profession, and to members of the Institute in particular.

RAE J. R.<sup>2</sup>

Microwaves from Coast-to-Coast, Gen. Elec. Rev., **56**, pp. 17-21, Mar., 1953.

STANSEL, F. R.<sup>1</sup>

Transistor Equations, Electronics, **26**, pp. 156-158, Mar., 1953 (Monograph 2066).

Circuit gain and impedance characteristics are given in terms of transistor parameters for grounded base, grounded emitter and grounded collector configurations. Simplifying approximations are given where appropriate.

VARNEY, R. N.<sup>6</sup>

Drift Velocity of Ions in Oxygen, Nitrogen, and Carbon Monoxide, Phys. Rev., **89**, pp. 708-711, Feb. 15, 1953 (Monograph 2081).

The drift velocities of ions of the parent gas in oxygen, nitrogen, and carbon monoxide have been measured as a function of field strength to pressure ratio by techniques previously reported. Oxygen gave results similar to those in the rare gases reported previously. A log-log plot of drift velocity against  $E/p_0$  in volts/(cm/mm Hg) starts with a slope near unity which gradually decreases to one-half at high values of  $E/p_0$ . The mobility, extrapolated to zero field and atmospheric pressure is  $2.25 \text{ cm}^2/\text{volt-sec}$ . Nitrogen and carbon monoxide both show a novel characteristic; the drift velocity first rises with  $E/p_0$  but reaches a maximum and actually decreases, then finally resumes a more normal rise with  $E/p_0$  as described for oxygen. It is believed that a high  $E/p_0$  the drift velocity is characteristic of  $\text{N}_2^+$  ions and  $\text{CO}^+$  ions, respectively. At low fields the ion in nitrogen is believed to be  $\text{N}_4^+$ . In CO the ion at low fields is believed to be  $\text{CO}^+$ , with  $(\text{CO})_2^+$  being formed at intermediate fields. The results are complicated by an additional ion which appears in the range of  $E/p_0$  from 95 to 250 and which has a higher speed than the other ion. It is suspected of being  $\text{C}^+$ .

<sup>1</sup> Bell Telephone Laboratories, Inc.

<sup>2</sup> American Telephone and Telegraph Company.

<sup>5</sup> Sandia Corporation.

<sup>6</sup> Washington University, formerly with Bell Telephone Laboratories.



WANNIER, G. H.<sup>1</sup>

Connection Formulas Between the Solutions of Mathieu's Equation, *Appl. Math. Quart.*, **11**, pp. 33-59, Apr., 1953 (Monograph 2082).

The problem of connecting the various types of solutions of Mathieu's equation is solved by the introduction of a new parameter  $\phi$  which is a function of the two equation parameters  $a$  and  $q$ . This quantity  $\phi$  is introduced and enclosed between two very close analytic limits in section 2. In sections 3, 4, 5 precise definitions are given and information is collected for the three main types of functions which are to be connected. Section 6 contains the connection formulas. Section 7 reviews the status of knowledge achieved. Section 8 is an appendix on integral equations which are more general than those developed earlier in the text, but which appear to be of no use for the main purpose of this paper.

WALKER, J. G., see R. M. Bozorth.

WICK, R. F., see W. P. Mason.

---

<sup>1</sup> Bell Telephone Laboratories, Inc.



## Contributors to this Issue

FRANK R. DICKINSON, B.S., Union College, 1927. Bell Telephone Laboratories, 1931-. Mr. Dickinson has been primarily concerned with the development of carrier telephony and is currently working on the L3 carrier system. During World War II he was engaged in the development of airborne radar bombsights. Member of Eta Kappa Nu.

H. F. DODGE, S.B., Massachusetts Institute of Technology, 1916; Instructor, Electrical Engineering, 1916-17; A.M., Columbia University, 1922; Engineering Department, Western Electric Company, 1917-25; Bell Telephone Laboratories, 1925-. Mr. Dodge was associated with the development of submarine detection apparatus, telephone transmitters and electro-acoustic devices until 1924. He then joined the newly organized Quality Assurance Department and as Quality Results Engineer has been concerned with the development and application of sampling inspection methods, quality control techniques, and quality rating plans based on statistical methods. His group is also responsible for the preparation of Laboratories Inspection Practices. Consultant to Secretary of War, 1942-44. Shewhart Medal, American Society for Quality Control, 1949. Award of Merit, American Society for Testing Materials, 1950. Member of American Society for Testing Materials; Fellow of American Society for Quality Control, American Statistical Association, and Institute of Mathematical Statistics. Chairman of the American Standards Association Committee Z1 on Quality Control, the American Society for Testing Materials Committee E-11 on Quality Control of Materials, and the Standards Committee of the American Society for Quality Control. Co-author with H. G. Romig of *Sampling Inspection Tables* (John Wiley and Sons, 1944). Member of editorial board of Industrial Quality Control.

R. D. EHRBAR, B.E., Johns Hopkins University, 1937. Bell Telephone Laboratories, 1937-. Mr. Ehrbar is in charge of equipment design and field operations related to the development of the L3 coaxial system. During World War II he worked on radar development for the Signal Corps. Member of the Institute of Radio Engineers and Tau Beta Pi.



C. H. ELMENDORF, III, B.S., California Institute of Technology, 1935; M.S., California Institute of Technology, 1936. Bell Telephone Laboratories, 1936-. Transmission Systems Development Engineer, 1952. Since joining the Laboratories, Mr. Elmendorf has been associated with the development of the coaxial repeater system and is currently in charge of the group responsible for the development of the L3 coaxial system. During World War II he participated in the development of microwave components and airborne radar systems. Member of I.R.E.

TUDOR R. FINCH, B.S., University of Colorado, 1938; M.S., University of Colorado, 1939. After joining the Laboratories, Mr. Finch spent two years in the study of relay contacts. From 1940-46 he developed networks and circuits for radar applications and more recently networks for the wide-band L3 coaxial transmission system. He is currently engaged in transistor network development for both military and telephone applications. Member of the Institute of Radio Engineers.

ROBERT F. GARRETT, Graduate Electrical Engineer, Johns Hopkins University, B.S.E.E. 1926. Western Electric Company, 1926-. Worked since graduation as an engineer and as an engineering supervisor on various assignments with the Western Electric Company in the Engineer of Manufacture organization. These assignments include the design of factory testing equipment, the supervision of various departments engaged in the engineering planning for field maintenance test sets, spiral four carrier and microwave equipment. Member of American Society for Quality Control.

R. SHIELDS GRAHAM, B.S. in E.E., University of Pennsylvania, 1937. Mr. Graham has been principally concerned with the design of equalizers, electrical wave filters, and similar apparatus for use on long distance coaxial cable circuits for both telephone and television transmission. During World War II he designed circuits for electronic fire control computers for military use, and later developed methods for computing network and similar problems on a digital relay computer. Member of the A.I.E.E., Tau Beta Pi, and Pi Mu Epsilon.

E. I. GREEN, A.B. Westminster College (Fulton, Missouri) 1915, graduate student University of Chicago 1915-16, B.S. in E.E., summa cum laude, Harvard University 1921. Professor of Greek at Westminster College 1916-17; Captain Infantry Overseas Service 1917-19. American Telephone and Telegraph Company, Department of Development and Research, 1921-34; Bell Telephone Laboratories 1934-. From 1921 to 1940, and again from 1946 to 1947, Mr. Green was engaged in development work on toll transmission systems, principally in multiplex wire transmission. During the war, 1941 to 1945, he was responsible for



development of microwave test equipment for radar systems, radio monitoring and jamming equipment. In 1948 he was made Director of Transmission Apparatus Development, and in 1953 was appointed Director of Military Communication Systems. He is a Fellow of the A.I.E.E. and a Senior Member of the I.R.E.

ALEXANDER J. GROSSMAN, E.E., Rensselaer Polytechnic Institute, 1925. Bell Telephone Laboratories, 1925-. Transistor Network Engineer, 1952. Mr. Grossman has been engaged in the development of transmission networks since joining the Laboratories. Author of *Electric Wave Filters* in *Electrical Engineers' Handbook* (Pender and McIlwain, 4th ed.). Member of the Institute of Radio Engineers.

R. W. KETCHLEDGE, B.S., Massachusetts Institute of Technology, 1942; M.S., Massachusetts Institute of Technology, 1942; Bell Telephone Laboratories, 1942-. During World War II Mr. Ketchledge assisted in research related to infra-red detecting devices and in the development of sonar devices. After the war he spent two years working on the development of the Key West-Havana submarine cable system and from 1949-53 he was in charge of systems design for the L3 coaxial system. He was recently appointed Electronic Apparatus Development Engineer and is responsible for gas tube and storage tube development. Member of Sigma Xi.

BORIS J. KINSBURG, B.S., University of Southern California, 1926; M.A., University of Southern California, 1928. Southern California Edison Company, 1928-30; Bell Telephone Laboratories, 1930-. Since joining the Laboratories, Mr. Kinsburg has worked on research and development of broad band carrier systems using coaxial cable as the transmission medium. This includes amplifier development, study of cross-talk in coaxial conductors, requirement studies for coaxial equipment, equalization studies and television echo requirements and, currently, quality control studies of the L3 system components and reliability studies of the long-range submarine cable development. Member of the Institute of Radio Engineers, American Association for the Advancement of Science, and Society for Social Responsibility in Science.

ROBERT H. KLIE, B.E.E., Polytechnic Institute of Brooklyn, 1945. New York Telephone Company, 1930-42; Bell Telephone Laboratories, 1942-. After spending two years in the Commercial Relations Department, Mr. Klie entered a group engaged in the development of radar systems. Since 1946 he has worked on coaxial systems development. Member of Tau Beta Pi and Eta Kappa Nu.

M. K. KRUGER, B.S., St. Lawrence University, 1920. Engineering Department, Western Electric Company, 1920-25; Bell Telephone Lab-



oratories, 1925-37; Western Electric Company, 1937-49; Bell Telephone Laboratories, 1949-. Mr. Kruger spent a few years as an instructor in the student assistant course and then became engaged in the design of filters, networks, and transmission testing equipment. He devoted twelve years at Kearny to the design of shop testing equipment for transmission apparatus. Since 1949 he has been concerned with the application of quality control methods for the L3 carrier system and, more recently, with general quality assurance work. Member of the American Society for Quality Control and Phi Beta Kappa.

G. H. LOVELL, B.S. in E.E., Texas A. & M., 1927; M.S. in E.E., Polytechnic Institute of Brooklyn, 1943. N. Y. Edison Company, 1927-28. Bell Telephone Laboratories, 1929-. From 1929 to 1948 Mr. Lovell was concerned with the development of crystal filters for carrier systems. Since then he has worked on the development of broadband amplifier networks.

LESTER H. MORRIS, B.S., College of the City of New York, 1935. Bell Telephone Laboratories, 1928-. Mr. Morris' first assignments were in the calibration of standard telephone instruments and, later, the development of acoustic impedance bridges. From 1930 to 1935 he conducted research in loudspeakers and since 1935 he has developed repeaters for coaxial systems. Member of Phi Beta Kappa.

JOHN W. RIEKE, M.S. in E.E., Purdue University, 1940. Bell Telephone Laboratories, 1940-. A member of the Transmission Systems Development Department, Mr. Rieke worked on television circuits before and after World War II. During the war he assisted in the development of radar indicators, and currently he is engaged in the development of broad band television transmission systems. Member of American Institute of Electrical Engineers, Tau Beta Pi, and Eta Kappa Nu.

T. L. TUFFNELL, Bell Telephone Laboratories, 1927-1941, Western Electric Company, 1941-. With the Laboratories, Mr. Tuffnell worked on terminal equipment for transatlantic telegraph and telephone service, and the design of vacuum tubes for carrier telephone systems. His work in the Western Electric Company has been chiefly concerned with engineering problems related to the manufacture of vacuum tubes.

R. A. WADDELL, B.S. in E.E., Rose Polytechnic Institute, 1936. M.S.E.E., Ohio State University, 1938; Westinghouse Electric and Manufacturing Company, 1939-1941; Western Electric Company, 1941-. Since January, 1941, has been in various phases of product and test planning on test sets, varistors and coils used in the telephone system. Engineer Resistances and Spool Wound Coils, 1951-. Member Eta Kappa Nu.







414

---