

# COAL AGE

MCGRAW-HILL  
PUBLISHING COMPANY, INC.  
JAMES H. MCGRAW, *President*  
E. J. MEHREN, *Vice-President*

Devoted to the Operating, Technical and Business  
Problems of the Coal-Mining Industry

R. DAWSON HALL  
*Engineering Editor*

Volume 29

NEW YORK, MARCH 25, 1926

Number 12

## Evils of Substitution in Marketing Coal

TO DISTINGUISH one kind of coal from another, or "good" coal from "bad" coal, requires something more than casual inspection, and chemical analysis may be necessary. However, when a given coal is used its qualities are quickly learned, and its freedom from objectionable characteristics is soon apparent. To the ordinary consumer one coal looks like another and trade names are quite essential as a convenience in ordering and as an aid to marketing. Thus the coal trade is like marketing in other lines where trade marks are essential for the protection of an established business. Intensive selling by advertising in the coal industry requires, therefore, to be focused about a trade name, and where a coal of excellent quality has established a good market, this trade name becomes an asset and greatly assists in reducing general marketing expense.

But competition is keen and various expedients are invoked to overcome the popularity of a given coal. Some of these are above criticism, but others are decidedly unfair. Substitution of one coal for another is, unfortunately, a marketing practice that frequently characterizes a given locality. The coal dealer buys, at lower cost, a coal almost as good as an established coal and boldly sells it under the same name as the better coal, or else, if his conscience troubles him, he claims that it is just as good, which may or may not be the case. This practice is dishonest. More than this, it destroys the confidence of the consumer and he is not to be blamed if he harbors the opinion that coal dealers are generally unreliable. Wholesalers of the best type fight substitution as do coal retailers who have established their business on the basis of honest dealing with their customers.

No business can prosper that retains the disease of substitution. A producer who substitutes poor coal for the coal of better quality which he has been regularly supplying, is no better than the retailer who sells one coal under the name of another of an entirely different character. The producer should maintain his coal grades and the coal trade generally should eradicate retailers' substitution. Consumers' confidence is essential in every business, and where it exists sales resistance disappears and marketing costs are reduced to a minimum. Coal dealers' associations can render no better service to their members, than by ousting substitution through square dealing.

## Underground Superintendence Needed

A SHORT time ago a chief state mine inspector was heard to remark that mine superintendents who search tirelessly for causes of and protection against typical accidents, which recur with more or less frequency at their plants, are not in the majority. Perhaps this is due to the fact that the average superintendent does not spend as much time underground as he should.

Someone is required to co-ordinate the individual efforts of sub-bosses toward safety. Someone is needed to note where supervision fails. Every company should expect its superintendents to assume that responsibility, even where a safety engineer is employed.

Why is it that so many superintendents neglect the underground operations? Some are seen filling in at odd jobs at the tippie or some other point. They are to be commended for their energy but in the same breath criticized for their misconception of duty. They would do better to spend in the mine all of the time not devoted to performing their managerial duties on the outside.

Others are known to remain on the outside during the greater part of the time simply because they are not familiar with the "ins" and "outs" of mining, for which reason they let the mine foreman shoulder all responsibility for underground supervision. In such cases the companies that employ them—on the merit of business ability alone—are responsible. Two-headed authority at a mine plant does not lead to co-ordination of operations.

The superintendent should superintend. If he is to accomplish the purpose for which his company has employed him he must allocate his time to duties in proportion to their importance. Certainly underground operations are at least half of the works.

## The Architect and Solid Fuels

IN PACIFIC COAST cities and towns recent residence construction is being too greatly influenced by the fuel situation, which situation is for the moment dominated by oil fuels and gas. The exigencies of cheap residence building have resulted in the elimination of chimney construction in many instances, or where chimneys are constructed, they are not infrequently of flimsy design or of use only for fireplaces. The better architects, recognizing that even in especially favored localities heating furnaces are highly desirable, provide a chimney for this purpose. In not a few instances the chimney is badly located, necessitating long connecting pipes which require frequent cleaning; chimney flues are often too small, resulting in insufficient draft and cleaning expense. Where coal is burned as a fuel under these conditions considerable inconvenience and annoyance results and salesmen for oil-burning equipment and for gas heating appliances take full advantage of the situation to the detriment of the coal business. A properly placed chimney of ample flue dimensions with a good coal-burning heating furnace is easily one of the safest and most satisfactory heating units for residence purposes. If care is taken in the design of the installation, coal can be almost as conveniently burned as oil or gas and it is invariably cheaper both in first cost and in operation. Gas fuel is probably the most convenient but it costs a great deal more for operation. Fuel oil requires special equipment and there are also



elements of danger of several kinds in its use by inexperienced persons. Use of coal fuel requires a knowledge of a few simple rules in stoking and once these are learned the heating furnace gives very little trouble and requires only occasional attention. Necessarily care must be taken to select a suitable coal, preferably one that cokes and does not clinker. Very soft coals are not satisfactory.

Although oil fuel at present dominates upon the Pacific Coast, even a state like California uses much solid fuel and many householders prefer this to any other. Needless to say, a good coal burning heater is independent of interruptions of power or of gas supply. It avoids the noise of oil burners as well as oil leakage with its attendant fire risk. Conditions are rapidly changing in the petroleum industry and fuel oil prices may be expected to increase to a level that will again restore the advantage to coal. It is therefore the duty of architects in general to include in their residence and apartment plans adequate chimneys for burning solid fuel. Without this precaution the change from oil to coal may require reconstruction at considerable cost. No modern apartment or dwelling can be considered to be satisfactorily planned which does not provide for the contingency of changing fuels.

### Larger Copper

SMALL locomotives and 500-volt power were reasons for No. 2/0 trolley wire being adopted for the early installations in coal mines. A change of sentiment favoring 250 volts and the use of larger locomotives brought the No. 4/0 wire to its present position as the size most commonly used.

Now we have indications that wire larger than 4/0 is to come into use. One large producer in Pennsylvania is installing No. 6/0 trolley on the main haulways. The section of the wire is of such shape that it can be hung by the standard 4/0 clamps. It has a 59 per cent greater area than the No. 4/0 wire.

The trend toward larger mine cars and heavier locomotives makes it appear reasonable that there are numerous places where heavier trolley wire should be used. Paralleling the trolley with a feeder cable gives the same effect but is a more expensive method. Difficulties of handling solid copper in sizes above 4/0 will no doubt be the limiting factor in future developments toward the larger wire.

### Laying the Ground for Accord

PLEASING RELATIONS with the public need cultivation. We all know the individual who means well but is always arousing the animosity of people because he does not give due consideration to his manner of approach. His heart is right, but his actions so belie his purposes that explanations and excuses are continually necessary. And after all, one may as well confess it, he has faults of heart as well as faults of manner, and if he would give some consideration to these also, he would make a better sort of citizen—outwardly and inwardly better.

The coal industry needs a window dressing, and it needs certain internal reforms also. It needs to inquire just what these are and not to wait as it has been in the habit of doing till the public is in an irritable mood. Explanations at such a time do not explain, apologies even do not mollify.

Anyone who has seen two persons trying—honestly trying—to compose an ancient quarrel will recall how a trifling word or action has almost invariably ended in creating a condition more vexed and harassing than existed before, a disagreement that was slumbering and dying being suddenly revived and bursting into flame once again, making pacification more hopeless than ever.

To take a suggestion from pathology: A food that will cheer and sustain a healthy person will be poison to his system when he is sick and ailing. The disease will turn the best of viands into an intestinal irritant. Important, therefore, is it that the body be kept in health, so that it may be able to assimilate the food it needs. Important also is it that the public may have a mind so unsoured that it can judge without prejudice and be prepared to accept the operators' statements at their right value.

But to attain that end must be a long record of honorable dealing with no lapses. E. E. White, formerly of the E. E. White Coal Co., recently denounced the action of those producers who raise prices to an exorbitant level and send impure coal to market and so injure the business of other operators. This has no reference to the history of the recently concluded anthracite strike or to the action of the bituminous coal companies consequent thereon. There was not, as far as the coal producer was concerned, any profiteering, and it has not been the practice in the past of the larger companies, in times of big demand, to force prices to the top level. Repeatedly they have met together, to save the public from high prices which competition has induced.

### Oil Must Be Combated

THE abnormal development of petroleum, especially in the California oil fields, has unsettled established business in coal, particularly in the marine bunker trade on the Pacific Coast, which is now greatly restricted. In Pacific Coast ports fuel oil has displaced coal and has reduced the marine market to nominal proportions. Recently plans were advanced to convert the coastwise vessels of the Canadian government merchant marine from coal to oil burners. This would have been consummated, but for the protests of the British Columbia coal interests. Success attended their efforts and it is understood that the contracts for the change in equipment are going to be or have been cancelled.

This incident brings into prominence the need of the coal industry to protect its markets from encroachment. Declining production in the petroleum industry foreshadows increased prices and a diminishing surplus. The increase in cracking practice indicates a more profitable use for petroleum than for fuel purposes. Thus, although present prices favor fuel oil, it does not necessarily follow that this condition will be maintained for a long period, and it may be quite temporary. It is, therefore, unwise for marine or other established solid-fuel users to be too greatly influenced by low price levels that characterize flush production from new oil districts. Nevertheless, the situation is such that coal men generally should study the situation and take steps to maintain their existing markets by either raising the quality of their coal or by suitable price adjustment to meet liquid fuels.



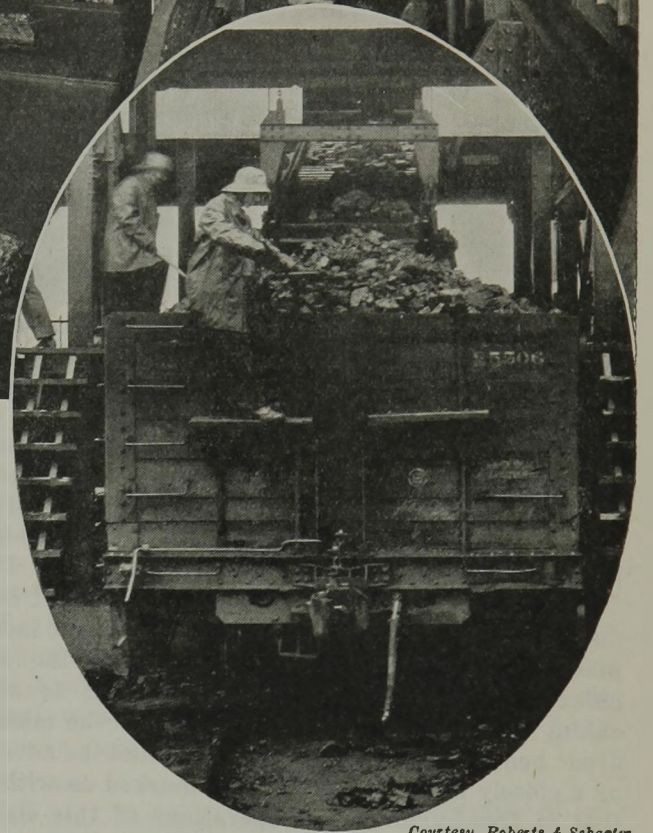
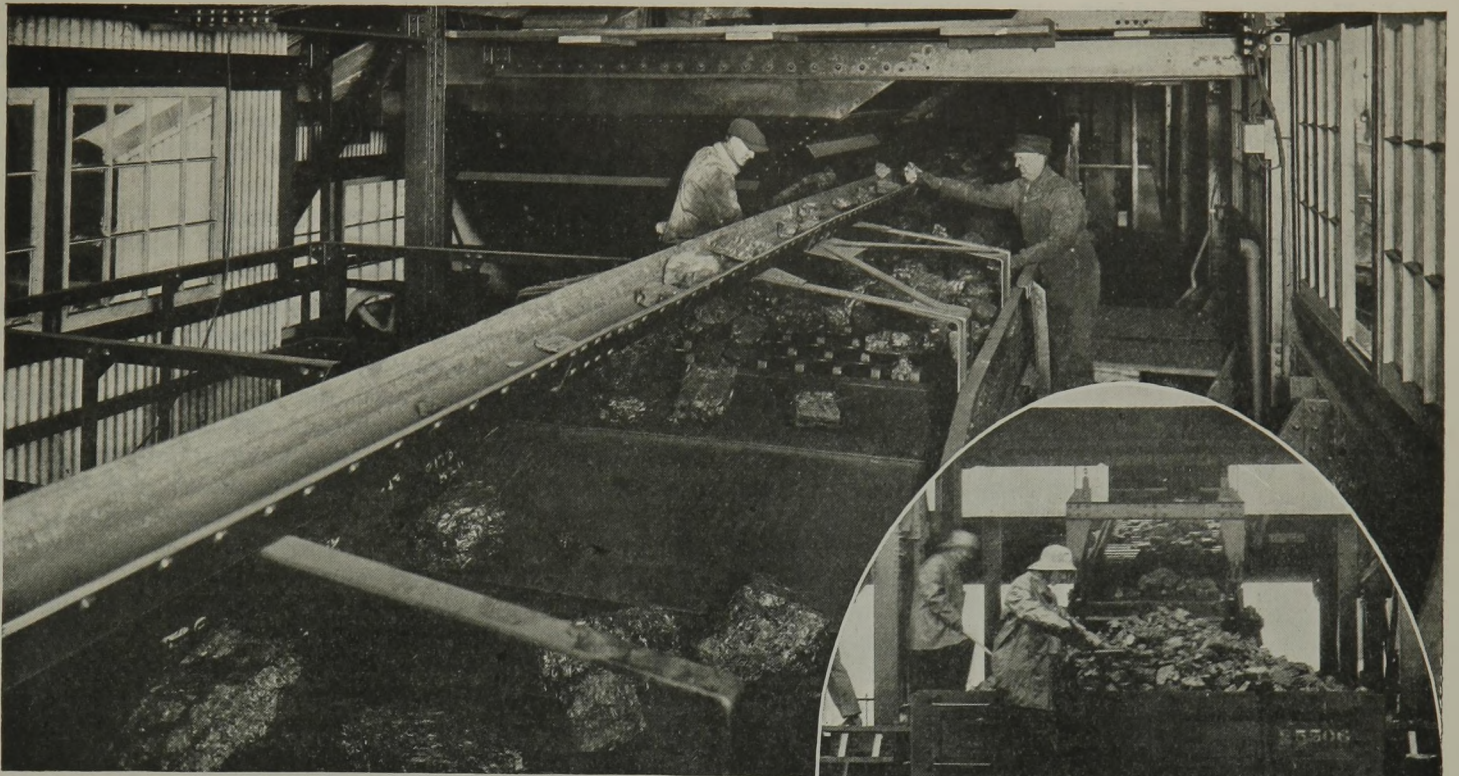

Courtesy, Roberts &amp; Schaefer

## How Coal May Be Sized And Hand-Cleaned For the General Market

With Machine Loaders Much  
Refuse Comes to Tipple — Coal  
Should Move on Picking Belt Fast  
Enough to Keep Pickers Active

By Thomas Fraser

Assistant Professor of Mining, University of West Virginia,  
Morgantown, W. Va.

**C**ONDITIONS governing preparation of commercial coal differ materially from those which determine the treatment to be given to metallurgical fuel, defining as commercial coal the product that is to be sold on the open market as domestic or general industrial fuel. The introduction of mechanical or concentrated hand-loading systems for handling coal at the face will, in many cases, result in delivery of dirtier coal to the tipple than was previously received and hence will necessitate more careful attention in the preparation plant. If these new mining methods are widely adopted, the use of special cleaning devices will become mandatory at many commercial mines where heretofore it has been optional. Therefore, a study of preparation equipment and processes especially adapted to the preparation of coal for general market is timely.

The objects in commercial-coal preparation are (1) to size the coal to suit the requirements of the different users and (2) to free the coal of excessive extraneous impurities. The sizes to be made depend upon the destination of the coal under treatment; the domestic consumer demands well-sized coal free from slack; the

railroads use mine-run coal for the greater part, but demand a clean fuel and often prescribe a limiting percentage of slack; the steam plant may use mine-run, unassorted screenings or sized coal, depending upon the type of equipment. Profitable operation of a mine with all these markets available depends, in a large measure, upon production of a maximum proportion of those grades that command the highest prices, which are normally the larger sizes suitable for domestic use. To obtain the desired result, preparation of the best grade of coal must be the major consideration from the beginning of the coal-producing process, for the operations at the face and even the general layout of the mine—direction and width of working places, rate of advance, method of roof support and general transportation system—greatly influence the size of coal ultimately produced. Therefore, with regard to sizing as well as cleaning, preparation of the coal should begin at the working face. This, however, is not an appropriate answer to every argument for the installation of preparation equipment, though it is often so interpreted. Though preparation *should* begin at the face, it usually has to be completed on the surface if a high-grade product is to be shipped.

To produce the maximum proportion of lump coal, that object must be the determining factor in selecting methods of cutting, drilling, shooting and loading the

Headpiece shows scenes at the No. 2 Crown Hill Colliery of the Clinton County Coal Co., Clinton, Ind.



coal. For a commercial mine, one of the first requisites of a loading device should be ability to load lump coal broken down without any more violent shooting than is necessary for the best results in hand loading and, in any proposed changes in mining method, the effect on the size of coal delivered to the surface is one of the important features to be investigated.

### THREE GENERAL TYPES OF TIPPLES

In regard to the kind of preparation plant required, mines may be divided into three general classes, (1) mines serving, primarily, run-of-mine coal consumers, (2) mines shipping lump coal and screenings, (3) mines supplying miscellaneous domestic, steam, and railroad markets with sized coal. The large consumers of mine-run coal are the railroads and some kinds of steam power plants. Under unusually favorable working conditions that permit the coal to be mined free of impurities, a producer of mine-run coal requires only a simple surface plant equipped with means merely for dumping the coal and loading it into the railroad cars or barges without excessive breakage. If the conditions are such that clean coal cannot be produced at the face, a surface preparation plant should be provided to clean the coal and, as coal in the run-of-mine condition cannot be sorted effectively, screening is necessary as a preliminary step, if much dirt is to be removed. In such a plant the coal is separated by bar or shaker screens into products of a sufficiently limited range of sizes to facilitate cleaning by hand. These products are hand-picked on separate picking tables or belts and reassembled and loaded for shipment as picked mine-run coal.

Mines producing only two sizes of coal, that is, lump and screenings for the general domestic and industrial market predominate in many sections in the Appalachian region; especially where the coal is strongly caking. Coal of this kind fuses into a coke mass when fired; hence, sizing is not so essential and the advantages of a closely sized fuel are not so marked as with a coal that is free-burning. At operations of this class, bar screens are commonly used, with either 1½-in. or ¾-in. spaces producing 1½-in. lump or ¾-in. lump for domestic and hand-fired industrial furnaces and the corresponding sizes of slack for stoker use or for coking. Methods of cleaning depend upon the quantity and kind of impurities present, and whether they are found mainly in the lump coal or in the slack. If the coal is mined in a comparatively clean condition, the lump coal

is given a superficial inspection by the car trimmers, and the slack is shipped as mined. If more thorough preparation is necessitated by the condition of the coal or the demands of the market, the lump coal should be hand-picked on belts or tables before loading; the slack can be cleaned only by a washery or other mechanical treatment plant.

Cleaning by hand is greatly facilitated if the coarse coal is screened into several sizes for separate treatment. This is done at most commercial mines that produce both domestic and steam coal of the free-burning type and at many mines working coking coals. This sizing is usually done with shaker screens, but bar screens may also be used for this purpose. Shaker screens have the advantages of (1) handling the coal more gently, (2) using less headroom in the preparation plant, (3) sizing the coal more completely and (4) distributing and discharging the separate sizes more conveniently for subsequent treatment and loading. When lump coal, egg, nut, and screenings are made, the three larger sizes are well prepared for hand cleaning on picking belts. If the screenings are to receive further preparation, mechanical means are necessary as hand-picking the very small size is prohibitively costly.

### NUT IF DIRTY NEEDS MECHANICAL CLEANING

The economic limit of hand-picking depends upon (1) the cost of labor (2) the quantity of dirt in the coal and (3) the completeness of cleaning desired. The economy of preparing the nut sizes by hand is open to question and, if more than one- or two-per cent ash reduction is necessary, either 1 x 2 in. or 2 x 3-in. coal can probably be cleaned more cheaply, and certainly more effectively, by a simple mechanical cleaning plant than by hand.

No definite information is available on the effectiveness of hand-picking in terms of percentage ash reduction, or on the cost of hand-picking on the basis of dirt removed. O'Toole<sup>1</sup>, in a paper presented at a meeting of the American Iron and Steel Institute, showed that the cost of thorough cleaning of Pocahontas coal is very high when preparation of small coal by this method is attempted. However, his figures are for practically complete removal of dirt and bone coal which is not necessary at the usual commercial preparation plant.

Normally, with well-disciplined leaders, the larger

<sup>1</sup>O'Toole, Edward, Dry Cleaning of Coal by Means of Tables, American Iron and Steel Institute, May 27, 1921.

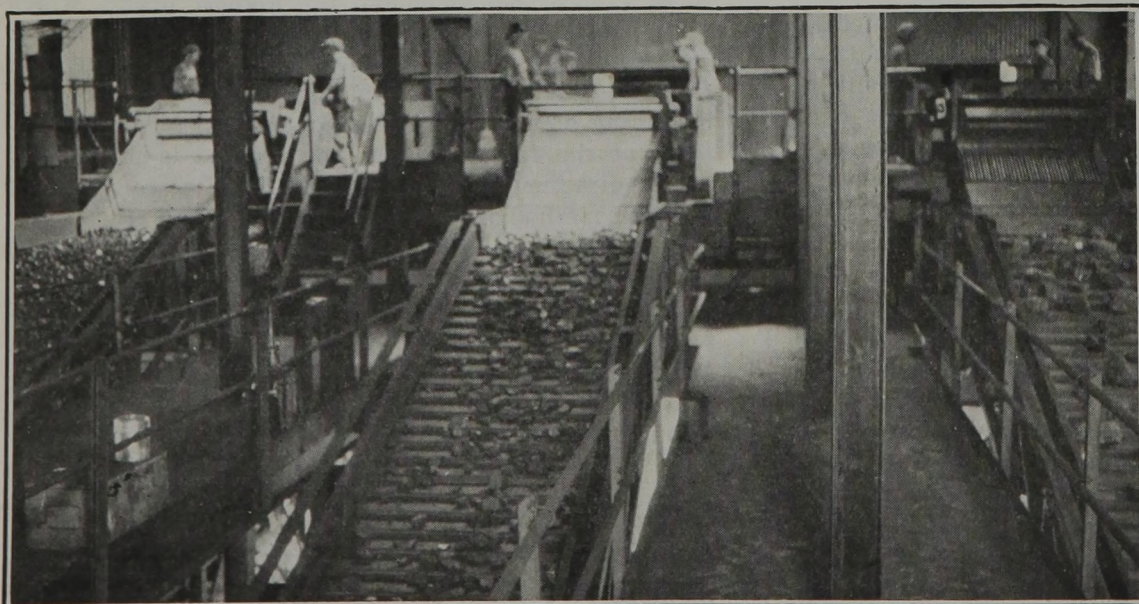

Plant with Three Picking Tables

Speed of picking has to be regulated to suit the quantity of refuse to be removed. Making it slower than is necessary has a despiriting effect on the employees who are likely to be more observant when they have more occasions to exercise their vigilance.



sizes of coal come to the tipple in such a condition that the removal of a small quantity of conspicuous free dirt is sufficient to insure shipment of attractive domestic grades of coal. Though no specific data are available on the cost of picking dirt from the various sizes of coal, the operation is not a complicated one, and the conditions in any given case should not be difficult to evaluate. It is basically a materials-handling problem—to identify and remove, piece by piece, the extraneous material in coal. Given the most favorable conditions for identification of dirt particles, the cost depends upon the capacity of a man for handling material, which will vary mainly with the size of pieces being handled. The proper and logical unit for expressing this capacity is net tons of dirt handled rather than gross tons of coal passed under the picker's observation. Therefore, the determining factors so far as coal characteristics are concerned are, (1) ease of identification of dirt, (2) size of coal, (3) quantity of dirt to be removed. The conditions that lead to the maximum proficiency of the worker are conditions that facilitate distinction of dirt from coal and that enable material to be removed from the coal stream and disposed of with the minimum effort or fewest movements. Conditions that facilitate identification of refuse are (1) good illumination without glare, (2) uniform size of pieces, (3) thin uniform layer of coal, (4) slow and steady movement of coal, (5) proper position of workmen at the picking table.

Conditions insuring maximum rate of handling material by the workman are (1) convenient arrangement of picking table, refuse conveyor or chute and workman, (2) uniform size of pieces, (3) thin uniform layer of material, (4) uniform and sufficiently rapid travel of belt to keep picker busy. As regards travel of belt, conditions for thorough cleaning and for maximum rate of material handling are, in a measure, conflicting. The best rate of travel for picking belts may vary somewhat with ease of distinction of dirt from coal, but it may be generally assumed that the highest rate that will permit ready identification and removal of pieces of dirt will result in maximum proficiency of the worker. For example, a given tonnage of coal passed before a picker on a belt traveling at the rate of 100 ft. per minute will probably be picked more effectively than the same tonnage in a layer twice as deep passed before him at the rate of 50 ft. per minute. In addition to handling the same tonnage in a thinner and better exposed bed, the faster moving belt necessitates a more wide-awake condition and quicker movements on the part of the worker, thus tending to increase his capacity.

Picking-table products are seldom sampled as a means of controlling or evaluating hand-picking operations. Hence typical data on results of hand picking are not available. Because the coal and dirt are often not broken



Picking Tables at Gay Mine, Near Logan, W. Va.

In this mine a large binder is removed by cutting the face two or three times. The coal is loaded by machine and when it arrives at the tipple receives careful inspection.

apart in the large sizes of coal commonly treated by this method, the refuse, as discarded, usually carries coal with it, and the average ash content of the rejected material is not as high as that of washery refuse. Picking-table refuse from lump and egg coal will usually run from 25 to 40 per cent in ash. A rough estimate of the reduction in ash obtained by picking may be made by weighing the total pickings obtained from the day's production of coal of any given size and calculating the ash reduction by the formula commonly used for figuring washery yields.

$$\frac{\text{Raw-coal ash} - \text{washed-coal ash}}{\text{Refuse ash} - \text{washed-coal ash}} = \text{Proportion of refuse (shrinkage).}$$

For example, if 1,000 tons of lump coal of 9 per cent ash content are loaded, the improvement that may be expected by picking out 30 tons (3 per cent) of refuse containing 40 per cent of ash is as follows:

$$\frac{9 - \text{cleaned-coal ash}}{40 - \text{cleaned-coal ash}} = 0.03.$$

From which, the ash content of the cleaned coal is calculated as 8 per cent.

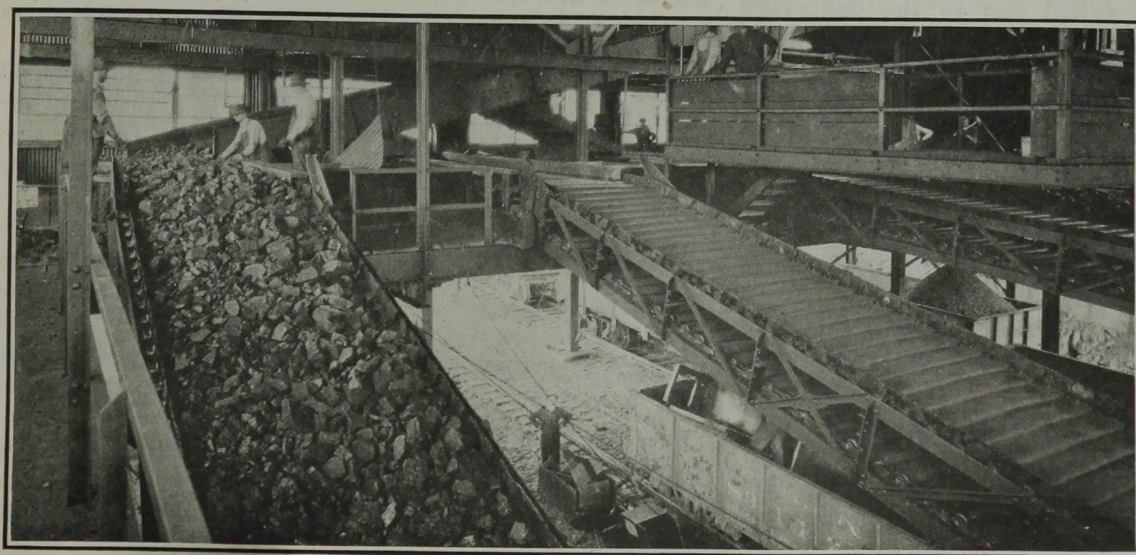

**Cleaning Strip Coal**

Coal from open pits is nearly always machine-loaded, and it was early found that it needed cleaning to make it acceptable to the market. This plant of the United Electric Coal Co. at Cuba, Fulton County, Illinois, has picking tables and loading booms in a well-planned tipple.



# Balancing the Helps and Hindrances to Success in Loading Coal by Machine

For Best Results in Machine Mining, Equipment Suited to New Agency Should Be Introduced in Every Phase of Mine Operation But These Improvements Can Be Made One by One

By Edward H. Johnson

Mining Engineer, The Coloder Co., Columbus, Ohio

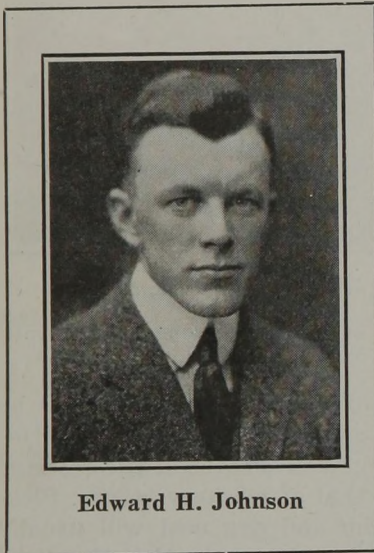

Edward H. Johnson

**I**N MOST of the coal mines of the country the addition of new machinery is a compromise. The management realizes that the new equipment cannot operate at 100 per cent efficiency, partly because of the natural conditions, but largely because of other equipment now in service that is sub-standard. A fan may be throttled by clogged aircourses, a pump by a corroded discharge line, mine locomotives by poorly

constitute one of these changes. After such a change has been made, the mine manager still has other equipment that was installed for a hand-loading operation. The haulage and face preparation faults at once appear. The question of cleaning the coal intrudes itself.

However, if this manager is resourceful and tenacious, and if the judgment of the purchasing official was good, an equilibrium is soon reached in the mining operation, and the cost of production is lowered. New opportunities will present themselves to straighten out the kinks, and as difficulties are solved cost will be further reduced.

Certain installations of loading machinery may have been successful because of unusual physical advantages in the mine, but success is more likely to be the result of a thorough study of all the problems involved. Let me list a few of these questions that have to be answered by the prospective user of machine loaders.

1. Is the loader adapted to the coal bed in which it is to work?
2. Can I supply the loader with empty cars that will enable it to load a satisfactory tonnage?
3. Are my power supply and my wiring and bonding practice adequate?
4. Can I provide sufficient auxiliary cleaning underground or at the tippie, with an added cost that I can safely absorb?
5. Can I make such changes in my system of mining as may be necessary?
6. What will be the effect upon my labor relations?
7. Can I prepare the coal so that the machines can load it readily and with a minimum degradation?

## MACHINE MUST BE ADAPTED TO COAL BED

An unfavorable answer to any of these questions will make successful mechanical loading difficult until corrections can be made. Many of the mines subject to competition that cannot give favorable answers to these questions are due to be eliminated. This is an admitted fact by mine operators. I wish briefly to comment on each of the questions that I have listed.

The choice of the proper loader should not depend upon the skill of the salesman. It is a problem for engineering analysis. In general the best answer will be found through recourse to consulting engineers or firms, who should have the data at their disposal.

Even where conveyors or scrapers are used the haulage system may interpose a stumbling block because of delays in the changing of cars or because the mine cars are of small capacity. The question mentioned "satisfactory tonnage," not "maximum tonnage." This is a rather important distinction. A maximum output may result in higher unit costs of haulage or maintenance than 80 per cent of that maximum. The law of diminishing returns will be found to apply to machine loading. Though the operator may not be able

ballasted mine track, mining machines by low voltage, haulage by inadequate hoisting equipment. To an even greater extent mechanical loaders must make concessions to physical restrictions and unbalanced mine machinery.

The loading-machine salesman who rates his machine at a certain tonnage is either mentioning conservative figures or is taking much for granted. Overzealous estimates and unjustified claims have greatly delayed the ultimate success of loading machines. Rare indeed are the loaders that develop a 40 per cent time efficiency, and even these may suffer further losses incident to low voltage or improper face preparation of the coal. No machines used underground today are so dependent upon the proper co-ordination of other mine equipment and upon the mental attitude of the management and the employees. I know of one installation where the loaders have failed due to the deliberate intention of the management to discredit their operation. But as the electric hoist is superior to the windlass, as electric haulage is better than hand tramming, so is machine loading better than hand loading and bound to supersede it.

Every mine manager is familiar with the problem of getting the highest possible yield with the machinery and labor available, efficient and otherwise. What he might do with other means is likely to be only of academic interest except as individual changes in equipment and personnel may be found possible. The introduction of one or more mechanical loaders may

Article entitled "The Engineer's Viewpoint of Mechanical Loading" read before the "Materials Handling Division of the American Institute of Mechanical Engineers," New York City, Mar. 11. Mr. Johnson was the joint author with F. E. Cash of the bulletin on "Mechanical Loading in Coal Mines" published by The Carnegie Institute of Technology and the U. S. Bureau of Mines.



to increase the capacity of mine cars, such a change, where possible, is of definite advantage in any sort of mechanical loading.

There is inevitably a loss in efficiency of the haulage because machines do not load mine cars as heavily as do hand loaders, except in the rare instances where the loaders are paid by the car. This has resulted in an actual loss in tonnage where the hoist has been operating at its maximum capacity. Sometimes sideboards which add to mine-car height will overcome this difficulty. A machine-loading operation will require just as many mine cars as one operated by hand loading provided the cars are of the same average capacity. That is, it is generally agreed that more mine cars of the same size are needed with a mechanical loading operation.

There is no mystery about wiring practice, track bonding and devices to maintain and protect the voltage. The best methods are also the safest and their introduction will be fully justified.

Coal cleaning is an important problem, as wet or dry launders or hand picking have to accompany most of the loader installations. One comforting fact has been established. The increase in the refuse in machine-loaded coal is in the larger sizes. The small pieces of refuse that escape the eye of the men on the picking tables have also been missed in the past by the hand loader at the face. Refuse carried out with the coal represents a slight loss in haulage efficiency and creates a further waste-disposal problem on the surface.

Changes in the system of mining are often considered to be a part of the machine-loading problem. The use of certain of the loading devices on the market depends upon minor or major changes in mining methods. The mining handbook of the American Mining Congress warns us that room and pillar mining is institutional and that radical changes are of doubtful value. Major changes in existing practice have in several cases discredited the cause of machine loading because instances have occurred where the new mining system has failed.

Any mining system that contemplates a change in the method of controlling or guiding the roof action is an experiment in itself. Its success or failure will depend upon the engineering judgment that led to its adoption, almost independent of the loading devices that are used. This statement must be qualified by the admission that the rate of advance or retreat of the working face will naturally be governed by the degree of success of the machinery used.

#### ROOF-CONTROL METHODS NEED TRIAL

Although I am an enthusiastic advocate of long-face experiments and roof-control devices, I see these as problems to be solved individually in every mine. Changes in panel dimensions, room centers, track layouts, crew organization, and so on, may be considered as part of the machine-loading problem.

The attitude of labor is more of an individual problem for the local management than an issue to be considered in this article. The labor question is a problem in sociology rather than in engineering.

Face preparation of coal for the machine loader is a matter in which mine operators require as much education as the shotfirers. When the mine operator can be brought to see that the opening of cracks in the face of the coal, wide enough to allow the miner to insert his pick point, is *not* the proper way to obtain lump coal, it will be easy to teach the shotfirers. There

are too many mines in the country where the hand loader at a machine-cut face makes as many fines with his pick as the mining machine makes in undercutting. A new installation in Wyoming reports an increase in lump coal production with machine loading.

The mine with the best record of continuous operation in Illinois during 1925 is located in that part of the state that lies nearest to the coal fields of Kentucky, the low wages of which have kept many Illinois mines idle for the past two years. This mine is one of the few if not the only mine in that state that loads all its coal mechanically. The spread that exists between machine-loading costs and hand-loading costs, at least in high-wage districts, is a large fraction of the total cost, in some cases exceeding 50c. per ton.

The mine manager to whom this story comes, invariably says: "That is all very well, but my conditions are different." He is entirely correct. He sees the nature of his coal bed, the requirements of his market, and his equipment of men and machinery which are like none other in the land. It is possible that he is too close to his own problem to get a proper perspective of it unless he is a man of wide experience. Every mine is an individual problem, not to be solved by application of any general formulas. The mine superintendent should be consulted in making the choice of loaders, but he should not bear the whole responsibility for their success or failure.

#### NEED FOR MACHINES OF MANY TYPES

There is a constantly increasing variety of loaders from which to choose. Several of these machines are built to suit special conditions or to serve a particular purpose. Among these are machines that mine and load the coal, machines that load and convey the coal, and machines that work in conjunction with conveyors. Another class includes conveyors that are loaded by hand, which, although they are not loaders in fact, are generally considered in that connection. Some machines are portable and load either into mine cars or conveyors. No machine has been built to suit all conditions, so there is need for machines of several types. I believe that the industry has ceased to seek for something that will revolutionize it. We shall undoubtedly make better progress by a steady improvement of the means at hand than by waiting for the final perfected machine.

A degree of co-operation between manufacturer and operator is necessary to the success of machine loading and advantageous to both parties. By trying out ideas in machine design in the mines of friendly operators, the manufacturer has been able to discover and remedy the inherent weaknesses that are sure to develop. Thereafter it is the manufacturer's duty to maintain a standard of quality and workmanship that will permit operation with a minimum of delay and maintenance expense under the conditions for which the machine was designed. The manufacturer and his representatives should refrain from extravagant claims for his equipment. Statements should be based upon conservative estimates of competent engineers rather than enthusiastic sales propaganda. Failure to observe these principles places the operator in a defensive position.

The user of machines also has some obligations to fulfill. He should not blame the machines for failures that rightly come from defects in his own organization. Machines cannot load satisfactory tonnages if they are not properly supplied with empty cars, work-



ing places or rated voltage. Face conveyors of nearly all types will have a brief life of service if the coal is shot down onto them. Unless they are kept at some distance from the face the cost for replacement parts is sure to be high. This may be satisfactory to the operator, but in broadcasting his experiences particulars of operation should be given. Prospective users are accustomed to ask for trial installations and to demand that the machines make good without any help. Machines never become really successful until after they are paid for, and the operator has become convinced that he must make them succeed or suffer a loss. He will then know he cannot shift his burden on the manufacturer.

Mining codes and company regulations, when well enforced, operate to reduce the hazards of mining. Beyond this, many questions have to be settled by some one using his best judgment. The human element, particularly when adequate supervision is not the rule—and this applies to most hand-loading operations—is able to defeat the safety efforts of state departments and mine operators. To whatever extent it becomes possible to increase the man-day tonnage of underground labor, the fatal accidents per million tons mined will be proportionately decreased. The added hazard which may be expected through closer grouping of men in concentrated workings should be neutralized by the direct supervision thus afforded.

**SPECIALIZATION SHOULD INCREASE SAFETY**

Another factor of safety is expected to result from mechanization of mine operations. Nearly every man employed underground will be a specialist in some line, educated to his job. As such he can be expected to take better care of himself.

It is the duty of engineers to insist that safe equipment be specified, and it is the obligation of mine managers to provide for its operation in a safe manner. The United States Bureau of Mines defines in its certificate of permissibility not only the limitations of design but also the conditions of operation. Gears and chains should be guarded, electric motors should be enclosed, stray currents should be traced and eliminated, ventilation must be positive, supervision must be adequate and intelligent.

The operation of a coal mine is much like playing a game of chess; rather, a simultaneous series of games. In one game, the manager is matched with the requirements of his market, in another with his labor situation, in yet another with the physical conditions of his

property. In each game he is dealing with an infinite number of possibilities with a limited number of variables. Of necessity he must win each game. Mechanical loading may be a handicap in one game, but a decided advantage in another one. To accept a handicap in an easier game may be wise if that handicap is turned to an advantage in the more difficult game.

The general use of mechanical loaders will yield some results of general advantage to the industry. Large companies can dominate the field, because the coal pirate will no longer be able to raid the market. The destructive competition of low-wage fields in the natural markets of the higher-wage districts will be somewhat neutralized, as the direct labor cost will represent a smaller fraction of the total cost of production.

**BENEFIT TO THOSE WHO ARRIVE FIRST**

As there are now mechanical loaders that will operate successfully even under unfavorable conditions, the mine operators who first see the light and follow the pioneers will derive the greatest benefit in decreased costs of production and larger profits. The motto of the average man is this: "Be not the first by which the new are tried, nor yet the last to lay the old aside." Such operators will load their coal by mechanical means only when the competition of their neighbors drives them to it. The pioneering has been done. Who shall decide when we have advanced beyond the experimental stage!

The cause of mechanical loading might seem, from the foregoing discussion, to be beset with many difficulties. The importance of the pros and cons is not always to be judged by their number. The big advantage—cost reduction—is sufficiently large to be almost certain, if the engineering judgment is not at fault. There are many other savings and advantages, known as intangibles, which are not always reflected in the direct costs, but which result eventually in additions to net revenue. These may be merely mentioned. Their importance will be readily apparent.

Mechanical loading means concentration of mine workings; delivery of tonnage from one-quarter to one-half of the present developed area; rapid development and recovery in new properties, resulting in quicker, therefore greater, returns from the original investment; saving in timber through the more rapid evacuation from the territory being operated; saving in steel rails, mine ties, trolley wire and bonds for the same reason; possibility for better supervision and greater safety for men and machinery.

**Coal Is Cheapest for Heat Treatment of Metals**

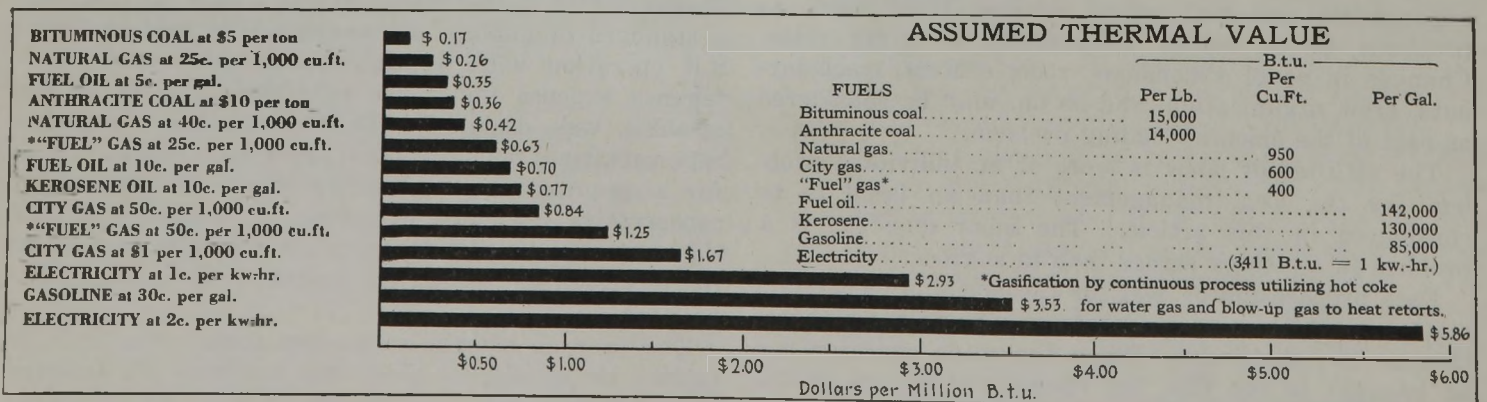

This chart, compiled by the W. S. Rockwell Co. of New York, is intended to show that, upon a basis of cost per million B.t.u., coal is the most economical of all sources of heat for the treatment of metals. The chart covers the comparative cost at assumed unit

prices and assumed B.t.u. per unit of consumption of fuel. Furnace design and many other factors enter into the heat treatment of metals but the fuel cost, taken alone, is represented here. It is heartening to see what a lead bituminous coal has over all rivals.



# Wet Haulage Slope Kept Free of Ice by Split Of Air Passing Up It

Abandoned Old Slope in Coal for a Steeper Slope in Rock That Saved Trackage to Tipple—Use Former Slope as Intake—New Road Reduces Height Coal Has to Be Hoisted

By Thomas Murphy

Master Mechanic Northwestern Improvement Co.,  
Roslyn, Wash.

BY MAKING a new slope in the roof rock, the Northwestern Improvement Co. shortened its haulage underground nearly half a mile and cut down its surface haul almost three-quarters of a mile. This gave a more permanent slope and one that had a grade more nearly in accord with that of its extension within the coal bed. Moreover, it saved hoisting the coal as high as was formerly the case, the top of the new slope being 120 ft. lower than the top of the old one. But the new slope was wet and icy in the winter season, so 2½ per cent of the air delivered to the mine was allowed, in the winter months, to pass back out of the mine up the slope. This kept the roadway in good working order. The old fan was kept in place and could be run by steam-driven power equipment provided the hydro-electric power-driven fan should be closed down for lack of current.

The Northwestern Improvement Co. at present operates three mines in the Roslyn-Cle Elum field of Washington, all of which are equipped with modern hoists, fans, and screening plants, and within the last year have been thoroughly rock-dusted.

This company's No. 5 mine was opened in 1904. The original opening was a slope starting in the bed, where the coal outcropped in a shallow gulch on the mountain side, and heading straight south down the pitch which is approximately 20 deg. at this point.

The main slope has an average width of 12 ft. and there is an airway and a manway on either side of the slope. Levels were turned off the slope east and west on about 500-ft. centers and driven 1 deg. to the raise. Rooms 20 ft. wide on 50-ft. centers were driven straight up the pitch. The old slope was driven down 4,000 ft. where the Eighth West and Ninth East Levels were turned.

## COAL BEYOND SLOPE PITCHES 36 DEG.

It was then found that the pitch of the bed increased to 36 deg. Diamond-drill borings disclosed the fact that this pitch continued for 2,000 ft. further south into a syncline. As all the coal had been worked out above the Seventh Level and as the 4,000-ft. haul up the old slope together with a 3,600-ft. locomotive haul from the top of the slope to the tipple was too expensive to operate, it was decided to drive a new slope on a 30-deg. 30-min. pitch through the rock to the surface from a point on the Eighth West Level 500 ft. west of the old slope.

The slope was driven 7x14 ft. for a double track and is 1,500 ft. long. An 800-hp. double-drum single-reduction geared hoist connected to a 2,300-volt slip-ring motor was installed to provide transportation.

The accompanying rock airway 7x12 ft. was driven

on a 45-deg. pitch. To provide ventilation a 6x7½-ft., double-inlet multi-vane fan, belted to a 75-hp. 2,300-volt induction motor, was erected.

In driving the new slope through the sandstone formation much seepage water was encountered, but no great quantity in any one place. After the slope was finished it was found that the seepage, amounting to about 25 gal. per minute, continued to come in through the roof, sides and floor. This was no serious matter in non-freezing weather—in fact it served a good purpose for it kept the slope damp.

This locality being east of the Cascade mountains there are usually two or three months of rather severe weather in the winter, and much trouble is experienced from the ice which forms on slopes when used as intake airways. As the old slope is being maintained to the Eighth West Level as a third opening to this mine, as required by the Washington state law, some air is taken in that way, the quantity varying with the outside temperature, being more in summer than in winter, as the top of the old slope is 120 ft. higher than that of the new one.

As the fan was still in place at the mouth of the old airway it was decided to force all the ventilating current down the old slope during freezing weather. This was accomplished by opening a crosscut between the old airway and the old slope near the fan, building a stopping in the airway just below the crosscut and installing a door in the mouth of the old slope. Now by operating the old fan as a blower at 100-r.p.m., 80,000 cu.ft. of air per minute is forced down the old

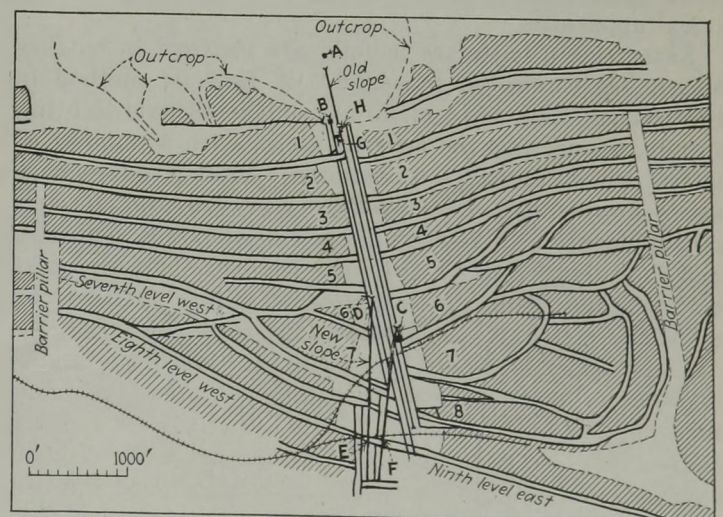

Slope in Roof Rock Decreases Maintenance Cost, Shortens Haul and Lowers Hoisting Lift

In the figure A is the old, discarded engine house; B is the old blowing fan; C is the new exhaust fan; E, D. is the new slope with its mouth at D; FC is the aircourse with its mouth near C; C is the new fan; G is the crosscut leading from the old blowing fan to the old slope and H is the door at the mouth of this slope.



slope onto the Eighth West Level whence 78,000 cu.ft. is taken through the mine by the new fan acting as an exhauster, the remainder, 2,000 cu.ft., passing up the new slope to the outside. Having been warmed by its passage down the old slope it prevents ice from forming on the new one.

The new fan is driven by an alternating-current motor by purchased hydro-electric power, as ordinarily no power is generated at either of the mines now being operated by the Northwestern Improvement Co. in this field. However, at No. 7 mine, which is located about one mile east of No. 5 mine, there is a 300-kw. steam-engine driven generator which is kept ready for emergency service at all times, consequently the old fan at No. 5 mine has been equipped with a 550-volt direct-current motor, the idea being that in case the power from hydro-electric sources fails the old fan motor can be supplied with power from the steam-driven generator at No. 7 mine and ventilation in No. 5 mine be maintained. It having been found that with the new fan shut down and the old fan running as a blower, all the change that is necessary to maintain ventilation is to close the steel fire door at the mouth of the new slope to keep the air from escaping at that point. The air then travels through the mine in the same direction as it does with the new fan running and passes out of the mine through the new fan.

## British Battery Charging Is Often Wasteful

With Celluloid Cases In Use It Is Dangerous To Draw Current From Lighting Circuits Unless Contacts Are Good and Leakage Prevented

By L. Fokes

Walton-on-Thames, England

**M**OST of the collieries in Great Britain have miners' lamps which, of course, have to be charged daily. The lamps are not, however, always charged in the safest and most economical way. Lamp rooms are often left in charge of more or less unskilled hands, yet the need for careful and intelligent treatment is perhaps more important than with many other forms of electrical apparatus.

Safety-lamp batteries usually are charged in batches which are connected in series. A favorite method in the British Isles is to make use of the electric lighting supply, connecting the cells in series with a number of lamps which act as a resistance. British mine managers apparently seldom realize how wasteful of electrical energy is this crude method of charging batteries and how dangerous is the practice with battery cases made, as is often the practice in Great Britain, of celluloid, which is an inflammable material.

The voltage employed for different systems of lighting varies considerably. In some instances, the pressure may be as high as 250 volts. There is a distinct danger of fire when charging cells on these higher voltages. Some manufacturers have abandoned the use of celluloid, but it is still widely employed for this purpose. Cells of this kind, of course, require the most careful treatment.

Quite mistaken ideas are prevalent as to the actual effect of introducing a resistance in series with batteries, which are to be charged from an electrical cir-

cuit the voltage of which much exceeds that of the cells connected for charging. It is often imagined that lamps or other forms of resistance reduce the voltage. They do nothing of the kind. They merely prevent the current exceeding a predetermined limit. Take for example

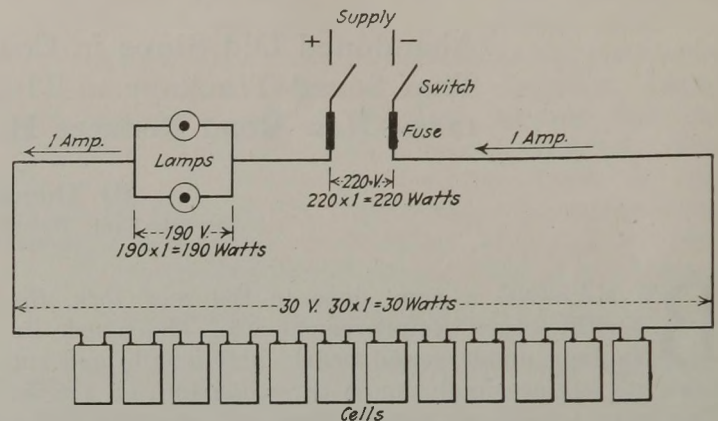

Fig. 1—Simple Charging Arrangement

Many people mistakenly think that lamps or other resistance reduce the voltage. In a case like this they merely prevent the current exceeding a predetermined limit.

a simple arrangement as shown in Fig. 1. It will be noted that the pressure of the supply is 220 volts, and twelve cells are connected for charging. The voltage of the cells in series when first connected may be between 20 and 24 volts. Obviously one or more 220-volt lamps—if more than one they will be connected in parallel—must be placed in series with the cells, the combined current of the lamps being equal to the charging current which may be assumed in this instance to be one ampere.

Now the voltage necessary to pass this current through the cells naturally must exceed that of the cells themselves, and a voltmeter connected across them when the current is passing might show 30 volts. If now the voltmeter be connected across the lamps the reading—assuming the wires have negligible resistance—will be the difference between 30 and 220, that is, 190 volts. Notwithstanding the fact that the pressure across the cells is 30 volts with current flowing, a broken connection in the batch of cells as indicated in Fig. 2 not only interrupts the current, but across the break there immediately exists the full supply voltage. It will thus be seen that a bad contact will give rise to arcing which might generate sufficient heat in the cell terminals to ignite the celluloid of one or both of the cells between which the defective contact has occurred.

### FIRE DESTROYS CELLULOID CASES

Further, if there is a complete break and the cell cases and charging stand are dirty or covered with a film of acid, the full pressure of 220 volts is sufficient to cause surface leakage, and many instances are on record of the complete equipment being destroyed by fire originating from this cause.

There are circumstances, of course, in which there is no practical alternative to this method of charging. In these cases the maximum of safety from fire can be obtained only by insuring that all terminals and contacts on charging stands are cleaned and secure. The stands themselves should be free from dirt and acid. A thin layer of fish oil will give effective protection against such leakage. Still it is unwise to leave altogether unattended cells that are being thus charged.

Nor is it generally realized at British mines how ineffi-



cient is the ordinary method of charging batteries from a lighting supply. The distribution of the power consumed in the simple charging circuit of the type described is shown in Fig. 1. Now the power in watts in a direct-current circuit is equal to the product of the voltage and the current passing. Thus in Fig. 1 we have a current of 1 amp. circulating through lamps and cells. The voltage across the whole of the cells equals, say, 30 volts as shown; therefore the actual power being absorbed in charging the battery is  $30 \times 1 = 30$  watts. Across the resistance formed by the lamps there exists  $220 - 30 = 190$  volts and therefore the power absorbed in this part of the circuit is  $190 \times 1 = 190$  watts. Thus we see that for every single watt consumed in charging the battery, more than six watts are wasted in the resistance.

On a similar circuit with the same number of cells the proportion of power wasted remains the same regardless of the capacity of the cells and their charging current.

It may be argued that the whole of the energy might be utilized in a 220-volt circuit by connecting in series, where a large number of lamps are employed, a sufficient number to absorb the whole voltage and dispense with anything but a small resistance for minor adjustments.

**FIRE RISK WITH SHORT CIRCUITS**

It would be extremely unsafe, however, for short circuits would have serious results, and fire risks would be extremely great. In general, it may be taken that no single series of cells should contain so many units as to require in excess of about 50 volts equivalent to, roughly, 18 cells. When a large number have to be charged they should be connected in parallel groups of 18 in series. For instance, in an installation where, say, 250 cells are charged for each shift these would be connected in 14 groups, and if each required a charging current of 1 amp. the total current will be 14 amp.

To charge these from 220-volt circuit under the conditions specified would give a distribution of power consumed in charging the cells and in the resistance respectively as follows: (1) In the cells  $14 \text{ amp.} \times 50 = 700$  watts. (2) In the resistance  $14 \text{ amp.} \times 170 = 2,380$  watts. In other words the actual charging would consume per hour 0.7 kw.-hr., and would waste 2.38 kw.-hr. This does not appear much on the face of it, but if this loss continues over say 4,000 hours a year the loss would be important in these days when coal-production costs have to be reduced to the minimum.

Undoubtedly the most efficient and in the long run

the most economical method of charging miners' electric safety lamp cells, is that customary in the United States and in some mines of Great Britain—by the

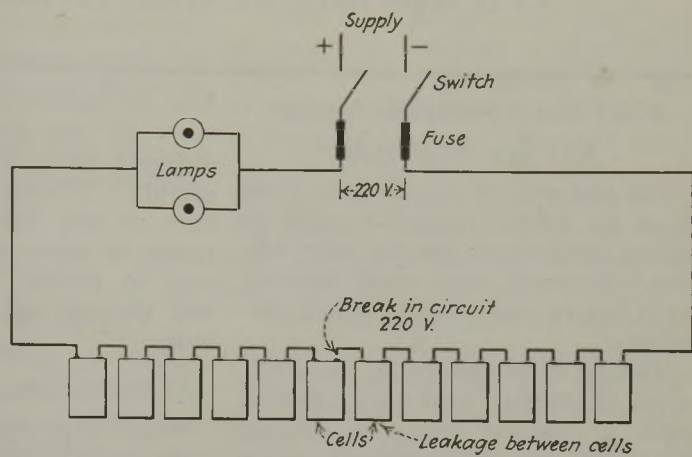
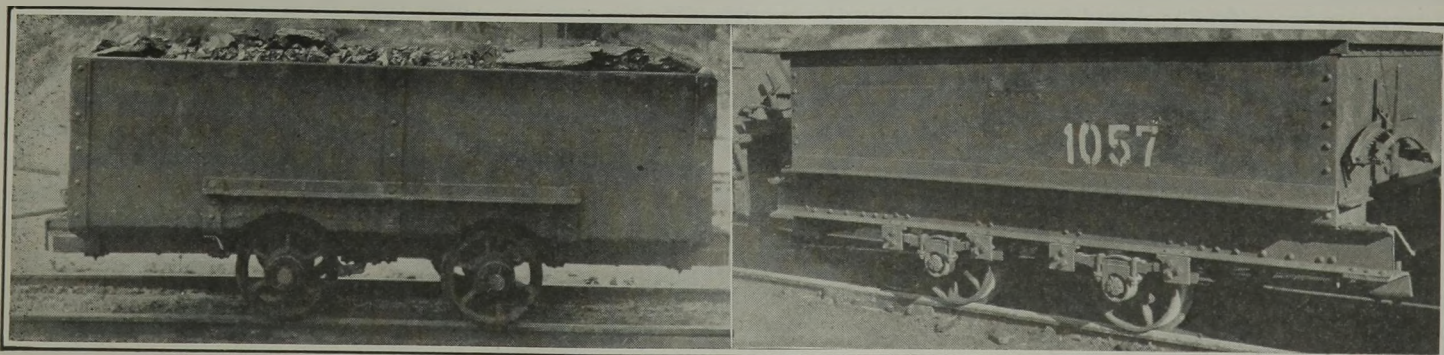

**Fig. 2—Danger Develops Here**

A broken connection in the batch of cells interrupts the current and across the break there exists the full supply voltage. Arcing might generate enough heat in the cell terminals to ignite the celluloid battery cases such as are often used in Great Britain.

use of the motor-generator set. Thus, if the supply is 220 volts, the set would be made up of a suitable motor to run on that voltage coupled direct to a motor giving a 50-volt current. Where, say, 250 cells are to be charged at once as in the case just considered, the energy required to charge the cells was 700 watts. If the combined efficiency of dynamo and motor is placed at 70 per cent, the motor would take about a thousand watts and, therefore, the power consumed in charging for say 4,000 hours would be 4,000 kw.-hr. as against 9,520 kw.-hr. charging direct from the supply in series with a resistance, or a saving of 5,520 kw.-hr. a year.

The depreciation on a motor-generator of this kind would be small, and its cost would be saved in two or three years, depending on the cost of power. In addition the voltage would be that most suitable to the work to be performed and even with celluloid battery cases almost complete security against fire. It should be stated that with a motor-generator set similar to the one described it is necessary to connect a rheostat in the shunt field of the motor for regulating the speed and in that way the voltage generated by the motor-generator set. This is because a somewhat higher voltage is needed to maintain the full charging current when the voltage of the cells begins to build up and opposes that of the motor-generator set. This may be obtained by slightly increasing the speed of the motor generator.



**Steel Cars Are Coming into Their Own in Phelps Dodge Corp. Mines**

The company, which operates a group of highly modernized properties at Dawson, N. M., has put 30 of these two types of cars into service and hopes to standardize on certain styles. The

one at the left has a capacity of 90.3 cu.ft. level full, and the other one of 90 cu.ft. Each type is equipped with roller bearings. That on the right is spring-mounted with spring bumpers.



## Viewpoints of Our Readers

### Coal Not a Suitable Agent For Ice Removal

The editorial of March 4 on "Coal as an Ice Remover" should cause no undue excitement among city officials concerned with snow removal for it has no real possibilities of usefulness.

Melting snow and ice by the application of artificial heat with different types of devices seems to present theoretical possibilities which never have been realized in practice.

As a youngster I recall the elaborate snow melting apparatus at Cooper Union, New York City, way back in the winters when Colonel Waring was boss of the white wings. Heat did melt the snow and ice, but apparently it was cheaper and quicker to haul the material by trucks to the waterfront and dump it into the East River. Next season the Colonel with his white uniform and fiercely waxed mustachio told the engineers at New York University about the unsatisfactory results of tests on melting snow.

#### MANY UNSUCCESSFUL TRIALS

Every time a big snowstorm blocks traffic and the newspapers reflect public impatience with street-cleaning methods, new devices and old friends in new dresses take pot shots at the impotent street cleaners trying to beat nature in her own sphere—not possible when the old lady is on a rampage.

Melting snow with steam, gasoline, fuel oil, electricity, hot water and salt have been tried time and again but with little success in New York. Salt is quite successfully used in Great Britain but climatic conditions are adverse in this country—our storms are more frequent and fiercer, temperatures before and after the storm are lower. Heat in various forms of application is a favorite panacea for "removing the snow as fast as it falls."

In reference books snow is quoted as weighing 5 to 12 lb. per cubic foot, but actually it weighs much more, so it is not safe to base any computations for heat treatment on anything less than solid ice. Again fresh snow is an excellent non-conductor, of the air-cell type and the specific heat as well as the latent

heat of liquefaction of a mound of snow on the street may be quite different from that of a laboratory sample. Whether this is actually true or not, the theory that it seems to agree with practical failures to remove snow expeditiously and cheaply by the application of heat.

#### VAULTS ALREADY UNDER WALK

Your suggestion about melting snow on sidewalks looks reasonable, casually considered, but apparently would require special and expensive new types of sidewalks because most large buildings in New York City already utilize the space under the sidewalk as vaults, many of which are heated. Sidewalk vault covers of steel supplied with heat from the building do not seem to melt snow and ice. There is something wrong with the theory of melting snow and ice by means of heat. It does not work in practice.

It would be interesting to design and estimate the cost of completely equipping two main thoroughfares in New York City for removing snow as fast as it fell. Better, however start with an outlying street without subways, water pipes, electric conduits, telephone ducts, pneumatic tubes, sewers, fire-alarm signals, etc., etc., and create a heat-conducting base and wearing surface for the pavement. No, I do not mean to be a joy killer—any possible improvement in speed and economy of snow removal in congested city districts is worthy of engineering thought and action but snow removal after all is more a matter of *organizing* and *managing available forces and equipment* than of creating special apparatus for emergency use—hardly ever justifiable economically or practically for snow removal.

New York City has drifted into the habit of spending five or six million dollars per snowstorm and why not? The newspapers recently quoted one of the District Attorney's staff as saying that half the six million was wasted or lost through grafting. Personally, I can hardly credit this statement, but it was published and nobody got "het up" over the situation. "What's the use?"

Having graduated from street cleaning to mining, I must say that the chances for expanding the coal or salt markets for snow removal do not seem to be bright, though queerer things have happened in this odd world of ours.

J. T. FETHERSTON,

Vice-president, Sterling Salt Co.  
Cuylerville, N. Y.

Commissioner of Street Cleaning  
New York City 1914-1918

### Trolley Installations Also Have Upkeep Charges

I read with much interest the editorial on "The Battery Locomotive," recently published in *Coal Age* and was greatly surprised to note the statement that *many* battery-equipped gathering locomotives were being converted into cable-reel type.

In my judgment the editorial is biased and not at all fair to the builders of battery locomotives or to the manufacturers of storage batteries, or even to the mining men who would take the statement as being one of fact. One would suppose from what is said that the day of the storage-battery locomotive in coal mines would soon be past; whereas the reverse is true, some of the leading coal companies of the country are doing away with trolley and reel and cable equipment and operating so-called wireless mines. In fact, such applications of battery locomotives are on the increase.

#### BATTERY UNITS INCREASING

When the editorial remarks that "many battery equipped gathering locomotives are being converted to the 'cable-reel type,'" it misuses the word "many." Let it be granted that there are a few isolated cases. What of that? The new equipment by far outnumbers the equipment being converted. I know of one builder of storage-battery locomotives who last year did more business than in any year since 1920.

You state the major reason for the change is the lump sum nature of the upkeep cost. I gather that you mean battery replacements. Would it not have been better to have gone a step further and explained that, by side-stepping the issue of the battery replacements, owners had better go slow or they would be jumping from the frying pan into the fire, as there are many daily operating costs which go hand in hand with reel and cable and trolley equipment. There is the constant purchase of



trolley-line material, bonds, the cost of installing the latter and the daily maintenance which this class of feeder demands. We then have an added expense of safeguarding the trolley wire at all passing points which, if not protected, will always prove a great hazard to the employees.

Eminent electrical engineers have made exhaustive tests and proved beyond doubt that storage-battery locomotives, from a power consumption standpoint, are the most efficient equipment ever designed for coal-mine service. By the use of trolley locomotives we have in most fields increased power bills and incurred a maximum demand charge. These costs coupled with the purchases of locomotive feeder cable, will ordinarily about equal the battery depreciation cost.

#### IS CLEANLINESS A NEW VIRTUE?

The editorial says that cleanliness is the secret of low cost of battery maintenance. Is not that the case with all classes of equipment? Why pick on the battery? As a matter of fact, a pail of water, a little soda and fifteen minutes' time, coupled with a reasonable degree of horse sense, applied each week will keep the batteries clean.

Give the battery locomotive sufficient capacity with which to do its work and I feel sure that in the majority of cases, it will win out over the reel and cable equipment, if all credits and charges are placed where they should be. One could go on further and bring out many operating features of an economic nature declaring the advantages of storage-battery locomotives over the reel and cable type, but to what end—they have been hashed and re-hashed in the very magazine that contains the editorial I am criticizing.

In conclusion, I would say that it has been my pleasure to operate fifty storage-battery locomotives for the past nine years and during that period this equipment has been the least of my troubles. Of course, the depreciation of the batteries is taken care of in a business-like way. Battery renewals are anticipated and the monthly depreciation costs allowed. Why use up the profits obtained by the use of such equipment for other purposes? Do the operators of reel and cable locomotives wait two or three years to pay their cable bills and maximum demand charges? No, they pay for them

monthly and any wide-awake operator will also take care of the monthly battery depreciation in the same manner. I write this as an expression of my personal point of view and not as being an official of a coal company.

JOSEPH A. LONG,  
Electrical Engineer  
Glen Carbon Coal Co.,  
Glen Carbon, Ill.

### Battery Locomotives Increasing

The editorial appearing in the Feb. 11 issue of *Coal Age* entitled "The Battery Locomotive," in my opinion is liable to be misunderstood. The actual facts on the use of storage battery locomotives, according to figures which we have carefully compiled each year, have shown that there has been a consistent increase in such equipment and the number of battery locomotives in service at the end of 1925 is 13 per cent greater than the number in service at the beginning of 1923, and, furthermore there are more storage battery locomotives in use today than at any time in the past. Tests have proved that they will gather in the same time and under the same conditions more tonnage than cable reel locomotives and at a lower cost.

#### QUESTIONS SUBSTITUTION

During the past year there have been few instances, found by our staff, of operators changing from battery-locomotive haulage to another system. If you know of any such instance and will make a complete investigation you will no doubt find, as we have, that the change is due either to misapplication or to gross neglect and abuse of the equipment, which is certainly not a reflection on the equipment itself. There have been a number of instances reported of mining companies changing from reel motors to battery motors. For instance, the Calumet & Hecla Mining Co. recently changed five reel gathering locomotives to battery locomotives; the Valier Coal Co. of Valier, Ill., changed two reel locomotives and we are informed that they expect to change several more before the end of the year. Reports that we have received indicate that more cable-reel motors are being changed into battery motors than is the reverse.

BATTERY MANUFACTURER.  
Philadelphia, Pa.

### Don't Use Acetylene to Form Cap of Safety Lamp

Your Feb. 11 issue of *Coal Age* on page 233, contains a short illustrated article describing an apparatus to aid in training firebosses in testing for gas. If methane were the gas to be used, the device and the idea could be heartily approved, but the use of acetylene as the testing medium introduces an unnecessary hazardous element.

The ignition point of acetylene and air is considerably lower than that of methane and air, the temperature range being 760 to 824 deg. Fahr. for acetylene and 1,202 to 1,382 deg. Fahr. for methane. Moreover, the oxyacetylene flame from 1 unit by volume of acetylene and 1.7 units by volume of oxygen has a temperature of 6,300 deg. Fahr., thus constituting one of the hottest flames that is used in industry.

#### ACETYLENE FLAME PASSES GAUZE

Under certain conditions, the acetylene passing through the gauze of the safety lamp will ignite and will produce a flame hot enough to heat the gauze, which in turn will ignite the gas outside the gauze but within the glass box, and an explosion will follow.

This is exactly what happened when a professor in one of our universities was demonstrating the principle of the safety lamp in a mixture of acetylene and air. The professor was knocked down and slightly injured, and the two observers were knocked across the room. The professor's apparatus differed from that described in *Coal Age*, in that a box that had contained permissible explosives was used. A small section of glass was introduced into one side of the box for observation. The explosion occurred almost as soon as the safety lamp was placed in the box, and the claim that the heat from the lamp caused the nitroglycerin absorbed by the box to explode is not worthy of serious consideration.

There will always be the hazard that a violently explosive mixture of acetylene and air may be present in the glass chamber and the introduction of the flame safety lamp is almost certain to ignite the mixture with disastrous results to those in the immediate vicinity.

R. E. SIMPSON,  
Engineer.  
The Travelers Insurance Co.,  
Hartford, Conn.



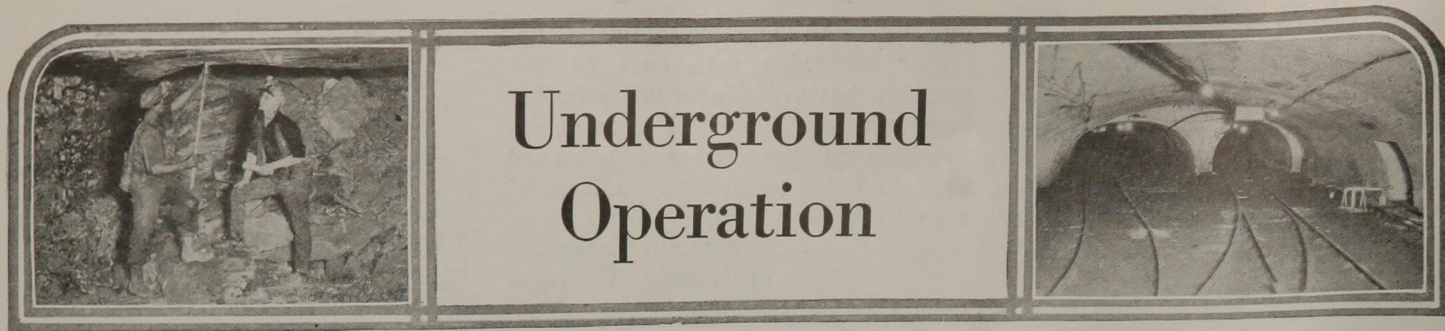

## When Ventilation Stops, Temperature Rises, Seams Expand and Emit Gas

Gas Gathers When Fan Is Run with One Opening in Mine Closed—Steam Pipes Cut Roof—Ribs Spall with Reduced Air

By F. C. Cornet  
Brussels, Belgium

Many years ago, at the time of the firedamp investigations made in Great Britain under the direction of Henry Hall, Inspector of Mines, numerous experiments were made to ascertain the influence of barometric pressure on the emission of gas at the working face. With the idea of creating an artificial atmosphere in a certain mine, the intake shaft was closed as tightly as possible by a wooden platform covered with tamped clay. The fan, an exhaust one, was kept running at its usual speed, thus maintaining unchanged the usual water gage, which was 2.36 in.

After 7 hours, when the air current had been so reduced that the anemometer did no longer revolve it was observed that the barometric pressure in the mine was only 0.157 in. lower than when the proceedings commenced. The emission of gas, however, had increased in the proportion of 235 to 100. This increase was considerably greater than the investigators had ever had occasion to observe in the same mine when, from natural causes, the mercury had fallen to the point where it was brought artificially by the means described above.

### NOT DUE TO PRESSURE FALL

It is evident that a factor, not thought of at the time, added to the decrease in barometric pressure to cause the large increase in gas emission observed by the British investigators. This factor, I am now inclined to believe, was the marked increase in temperature that must have made itself felt in the mine, especially along the working faces, due to the long interruption of the ventilating current.

That an increase of temperature at the working face may result in stimulating the emission of gas would have seemed a bold assertion a dozen years back. But at the present time, the idea is being accepted by an ever-increasing number of engineers who have had occasion to gain experience in the mining at great depths of gaseous seams of coal. The following array of proved facts may convert others to the same belief. Operators of deep mines well know how variations in temperature affect the cost of maintenance of underground openings. Despite the regulating effect of a deep intake shaft, the air reaching the bottom is always warmer in summer than in winter, causing more falls of roof, more caving of ribs, more swellings of bottoms.

### HEAT DESTROYS MINE

In a deep mine I know well, in the region west of Mons, Belgium, the cost of maintaining the haulways, which are all in the intake, was reduced in the proportion of 40 to 100 when electricity was substituted for steam to drive a certain underground pump. The steam was sent from the surface through a pipe placed in the intake shaft. This heated the air going down into the mine, with disastrous effects on the maintenance of the roads. That pipe is still there, but they use it only when electricity fails them.

On every such occasion, there is a prompt and marked increase in the cost of keeping the roads in good order. In other words, there is an immediate return to the old conditions. I might cite several other similar cases. One will suffice. It

must be noted here that, always, when for any reason, there is an increase in the temperature of a mine, all places affected by it bear their share of the resulting trouble: the strongly timbered roadways maintained through the gob and all the other places, timbered or not, driven in solid coal, or across the measures from seam to seam.

It would certainly be a difficult matter to explain scientifically why an increase in temperature is followed rapidly by an increase in strata pressure, but whatever the unknown cause may be, its effect has, long since, been recognized.

The rapidity with which the effect follows the cause is sometimes so great that a short interruption of ventilation may result in considerable damage. The fan must be kept running at working-day speed on Sundays and idle days when no one is occupied underground. Even in time of strike, ventilation must be maintained in full, in order to keep down the temperature of the workings.

The following test made recently for the benefit of a group of mining students is not different from similar experiments made in the course of every year for the same educational purpose. Nor does it reveal conditions worse than in the majority of the mines in the Mons region.

### LESS AIR, MORE GAS

The current ventilating a 360-ft. face was reduced, by short-circuiting, from 6,300 to 840 cu.ft. a minute. When the experiment began, little gas was issuing from the coal, although the seam is one subject to blowouts. The place was quiet and silent. In less than three hours, the timbers began to crack and bend, showing a heavy increase in strata pressure. The face became fissured from end to end. Gas was emitted abundantly, making a noise like that of running water. From time to time, splinters of coal, some weighing over a pound, were violently projected into the gob back of the



timbers. A student was painfully cut on the head by one of those flying missiles. Before the air current was short-circuited, a temperature of 68.6 deg. F. had been observed along the face. When the timbers began to crack, the thermometer showed 92.5 deg. F. Half an hour later, just before ventilation was re-established in full, the temperature was 96.7 deg. F.

One hour and twenty minutes later, all was quiet again along the face, although gas continued to ooze in some abundance, but silently, from the cracked and partly crushed, coal.

This experiment shows clearly, I believe, the mechanics of the heated strata. The increase in temperature has no direct effect on the gas contained in the seam. It is the increased movement of the strata that causes the coal to act as it does. The expansion of the seam which, previously, was slow, perhaps unnoticeable, became accelerated by the increased heat and that acceleration of seam expansion resulted in an acceleration of gas emission. In a previous article, one on gas blow-outs (*Coal Age* of March 1, 1923), I have shown what relation seam expansion and gas emission have to each other and why, the more rapid and complete expansion or crushing of a seam will be, more rapid and complete the emission of gas will also be.

### Hazardous Way of Shooting Coal Bottoms

In many mines the lifting of "coal bottoms" or "machine scrapings" (the coal left under the machine cut) is assisted by the use of explosives. Where this is the practice, holes are often dug with a pick and in each of these may be placed from one to two sticks of dynamite, this charge being generally covered with slack. The firing of thirty to forty shots consecutively in a single place is not unusual.

Some permissible powders when completely detonated in a drillhole, produce 158 liters, or 5½ cu.ft., of carbon monoxide for each 1½-lb. charge. Dynamite will produce several times that quantity of gas when exploded in a hole dug by a pick and lightly covered. Such shooting is scarcely to be differentiated from what might be termed shooting in the open. It is possible that 150 to 300 cu.ft. of carbon monoxide might be produced in a single place by

detonation at short intervals of the number of shots mentioned. That the concussion from dynamite shots is far greater than that produced by black powder is known to be a fact.

Therefore, to a greater degree the dust in the immediate vicinity is suspended in the air. This combines with a large volume of carbon monoxide in an explosive mixture which under the circumstances is cocked and primed for an explosion. When dynamite is fired it produces more or less flame, so that it is indeed surprising that under the conditions explosions do not occur with greater frequency, particularly seeing that so many mines follow the practices described.

#### ONLY IF RIGHTLY USED

In the opinion of the Bureau of Mines permissible powder is permissible or safe only when properly tamped with non-combustible material and completely detonated in a drillhole. The shooting of dynamite in dug holes which are covered with dust and slack is extremely dangerous. Where bottoms or scrapings are lifted by shooting, the explosive should be placed in holes which are properly drilled and tamped with clay.

Furthermore, men should not be permitted to break slate by dynamiting in the open. Instead short holes should be drilled in the slate and

these properly charged and stemmed, which practice is better and safer than shooting without confinement. I know of two explosions which were caused by what is termed "doling rock."

THOMAS G. HOYE.

Huntington, W. Va.

### Every Mine Should Build Its Overcasts to Standard

Most mines utilize much the same kind of materials in the construction of overcasts—hollow tile or brick, mortar, concrete, steel rails and sometimes reinforcing wire mesh. But the design of overcasts varies considerably. More or less uniformity or standardization in the construction of overcasts should prevail, for the duty of these air cross-overs is the same in every mine except for a difference in the volumes of air which are handled. Here are shown standard plans for the overcast construction in the mines of the Northwestern Mining & Exchange Co. near Dubois, Pa. They are so clearly detailed as to require no explanation.

The value of standards is that they prevent slovenly work by establishing a proper way to do everything by which actual accomplishment can be tested. Most overcasts need such a standard for as usually built they do much to interfere with the passage of air through the mine workings.

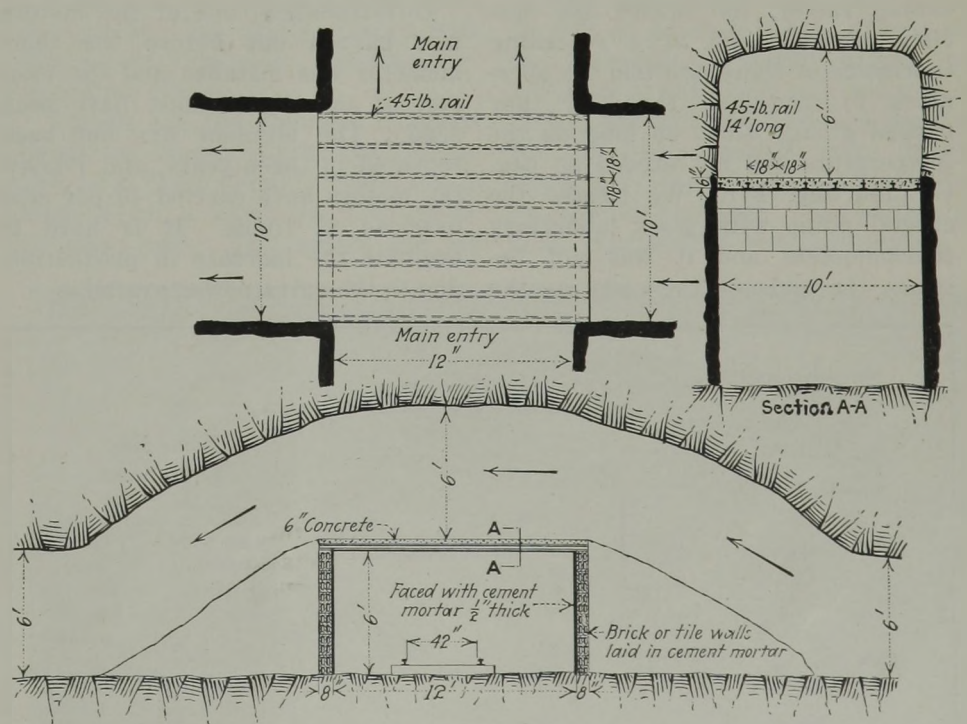

Standard Overcast of Northwestern Mining & Exchange Co.

Overcasts get little inspection, but they are of immense importance in mine ventilation. It is well to have a standard, so that poor work when discovered can be condemned as not according to schedule and there can be no rebuttal to the statement made. This overcast has a 6x10-ft. airway over the overcast and 6x12-ft. below. Apparently the upper airway carries only a part of the air circulating in the main roadway and does not need to be as generous in dimensions.





## Practical Pointers For Electrical And Mechanical Men

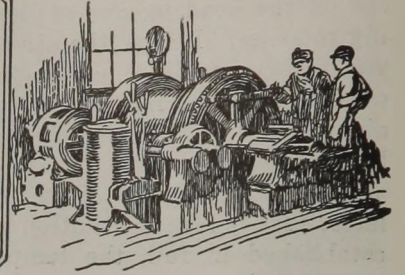

### Recording Thermometer Indicates When Load on Motor Is Safe

In our plant, says L. W. Cutler, in *Power*, there are two 50-hp. motors, which drive important machines, located where the room temperature is 40 deg. C. (104 deg. F.) in the summer and 21 deg. C. (70 deg. F.) in the winter. These machines are rated at 50 deg. rise above room temperature at full load and frequently are called upon to carry all the overload safely possible. In the winter we have little trouble, but in the summer it is evident that the over-all temperature is at the breaking-down point of the insulation. The usual method of limiting the current to full load rating or a conservative overload, by means of fuses or relays, could not be used, since the safe point would vary with the outside temperature.

Since the temperature of the hottest part of the winding was the governing factor, we located the specially shaped bulb of a recording thermometer there and told the operators to carry all the load they needed at any time, so long as the temperature did not exceed 85 deg. C. (185 deg. F.). We located the crucial point with glass laboratory thermometers and it was not between the ends of the coils, as the

manufacturers suggested. The hottest point was in one of the exit ventilation ducts in the center. Here the thermometer bulb could be placed in contact with a bar in the bottom of a slot. The instrument makers made a special bulb which was a nice fit to the ventilation duct. As there must be a limited relation between the volume of the bulb and that of the tube, we limited the length of the tube to 3 in. so as to reduce the size of the bulb. At that, the smallest thermometer stuck out of the duct about 1 in.

#### CONE RETAINS HOT AIR

A cone covering three ducts was fastened around the upper part of the thermometer. Thus, the protruding portion of the thermometer was bathed in the hot air coming from all three ducts.

Unfortunately, one of the motors was burned out before the thermometer was installed and the total cost of the repair must have been \$350. The accident has not been repeated in three years, and I know the motors have carried 40 per cent overload at times. It is hard to evaluate the increase in production, due to the extra power available.

### Spare Parts for Oil Immersed Switches and Starters

After finding one plant of large size without any oil circuit breaker or starter parts worth considering, and a much smaller one with a stock of repair parts large enough for the larger plant and realizing that this condition probably arises from a lack of proper information more than from any other reason, I will here try to give some plans for checking up on spare parts and the number required.

Some men do not realize the importance of keeping spare parts on hand for even the little oil switches and starters. Many a time a delay of several hours may be prevented by having available small oil switch parts that only cost a dollar or so, each when the delay might cost hundreds of dollars, or at the rate of hundreds of dollars per day.

Power plant breakers are not opened often but they are opened under extremely severe conditions, usually on overload, and nearly always with at least full load. As they are not operated frequently no large supply of fingers and contacts need be kept on hand. The number of switches in a plant that have the same amperage capacity should be set down and each switch that is not interchangeable with the others should also be tabulated. Each individual switch for 3-pole service, which is the type most used, should have at least one spare wood connecting rod and from one to three movable contacts, this number depending on the size of the breaker and the service to which it is put. Some companies make switches that have the movable contacts cast solid. In this case it is well to supply a full set of these contacts, so that the burned ones can be removed and be built up by the welding process, after which they may be ground down to template. They may then be kept for repair parts. Of course, breakers of this type are intended for severe service such as is encountered in

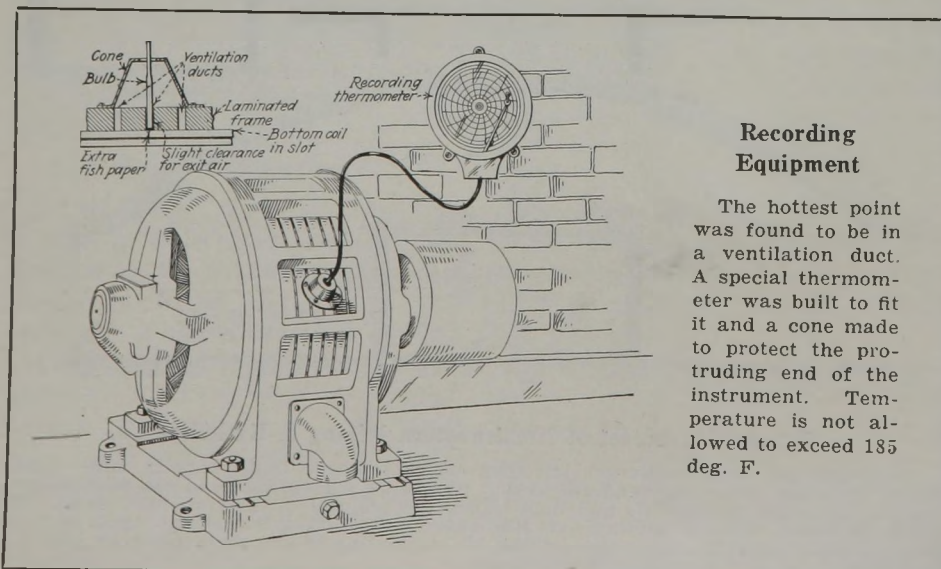

#### Recording Equipment

The hottest point was found to be in a ventilation duct. A special thermometer was built to fit it and a cone made to protect the protruding end of the instrument. Temperature is not allowed to exceed 185 deg. F.



rolling mills. All the stationary contacts generally burn or pit about the same time and consequently need renewal almost simultaneously. The contact fingers are fitted with springs that deteriorate and these, of course, must not be heated by welding. The number of fingers required for individual switches generally amount to a full set. It is a good idea to keep a few contact screws and bolts on hand in case any should be broken. From one to three porcelain bushings may also be kept on hand but these are seldom needed except in lightning cases. Lightning bursts bushings quite frequently especially those used in connection with large transformers.

Where a number of switches are of the same amperage capacity the number of repair parts carried per switch may be materially reduced. One complete set of contacts and two or three wood connecting rods will suffice for several switches. Of course such switches should be examined at least every three months.

**INSPECT SWITCHES MONTHLY**

Power plant switches should be inspected about once a month and contacts that are burned should be filed down while any that are badly damaged should be replaced, or removed and smoothed up with a mill file. The condition of the oil in the breakers has a great deal to do with the burning of contacts. Dirty oil increases arcing materially. Oil in low-voltage breakers can be strained through a clean muslin cloth and used over again, but that employed in high voltage breakers (above 600 volts) should be filtered if used a second time. Some companies put in new oil every once in awhile and use the old for lubricating slow speed line shafts and small mill bearings. However, this oil has only small lubricating value.

Oil-immersed auto-starters generally have more contacts than the average switch. The starting contacts as a rule pit and burn oftener than do the running contacts. In one manufacturer's equipment the movable contacts are usually of the segment type. These segments are fastened by small tapered-head screws, a supply of which should be kept on hand, because they have to carry the current and burn so badly that they are hard to loosen or tighten when replacing contacts. A full set of movable contacts also should be kept on hand as well as several fingers.

The Westinghouse company is developing a starter that has the least contact trouble of any that I have seen. This is the type "A 2 starter." With a pushing, rolling effect, the contacts on this device give little trouble. A few spare contacts will suffice for this starter, and the bolts that hold the contacts never burn.

Each new part as it arrives should be tagged with the nameplate reading of the breaker to which it is adapted as well as the number of breakers of this type operated and the circuits that they control. This facilitates repairs. It is advisable also to keep a record of parts used on switches and the dates when they were installed.

GRADY N. EMERSON.  
Birmingham, Ala.

**Scrap Gasoline Locomotive Used to Advantage**

During the last three or four years much equipment has been scrapped and replaced by machines of more efficient type. This, of course, was due to the urge for lower operating cost; and the same urge has caused many companies to utilize parts which previously had been thrown into the scrapheap.

The accompanying illustration shows how the Empire mine of the De Bardeleben Coal Co., Empire, Ala., utilized an old 7-ton gasoline locomotive by installing electrical in the place of the internal combustion equipment. Two 28-hp. motors, with single-reduction gears, were mounted in the old frame.

Except for the sandbox it would hardly be suspected that the locomotive is a "half breed." This box is made from a short piece of 10-in. standard pipe. The bottom and top

plates are secured in place by electric weld. The valve rod works in holes in the centers of these plates. The men at the mine are highly pleased with the performance of the locomotive and rate it as one of the best in their fleet.

**Alabama Mine Uses Neat Hanger for Wires**

For telephone lines inside mines, bare wire seems to be used more widely than insulated. A disadvantage of using two bare wires, as compared with an insulated twisted pair, is that twice the number of insulators are required and likewise twice as many holes must be drilled

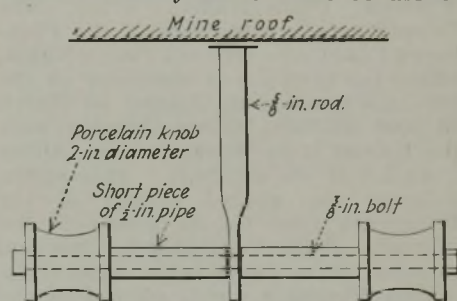

**Support for Telephone Wires**

This type of home-made hanger for supporting both wires from one roof bolt is used extensively in mines of the Woodward Iron Co., of Alabama.

unless some form of multiple hanger is adopted.

The accompanying sketch shows the arrangement used in the Mulga mine of the Woodward Iron Co., Mulga, Ala. The hanger is fastened in the mine roof and the wires carried on grooved knobs. The 3/8-in. rod forming the center support is flattened at the lower end and a hole drilled through the flattened portion for the 3/8-in. insulator bolt. When available, scrap pipe is used to make the spacing bushings. The hanger is neat, inexpensive and serviceable.

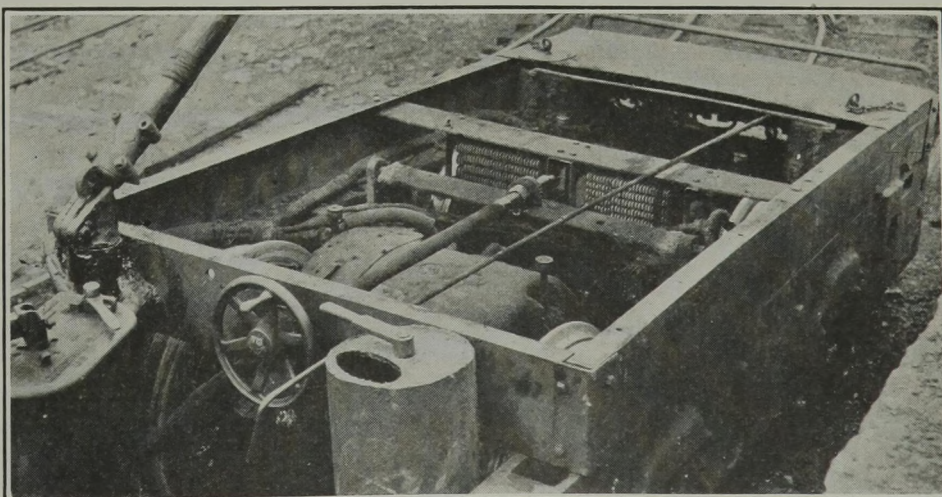

**Gasoline Equipment Replaced by Electric Motors**

When an additional locomotive was needed at the Empire (Ala.) mine of the DeBardeleben Coal Corp., a scrapped 7-ton gasoline locomotive was rebuilt by installing two 28-hp. 250-volt motors. When the photograph was made the locomotive covers were removed to show the inside arrangement. Single-reduction gearing is used.



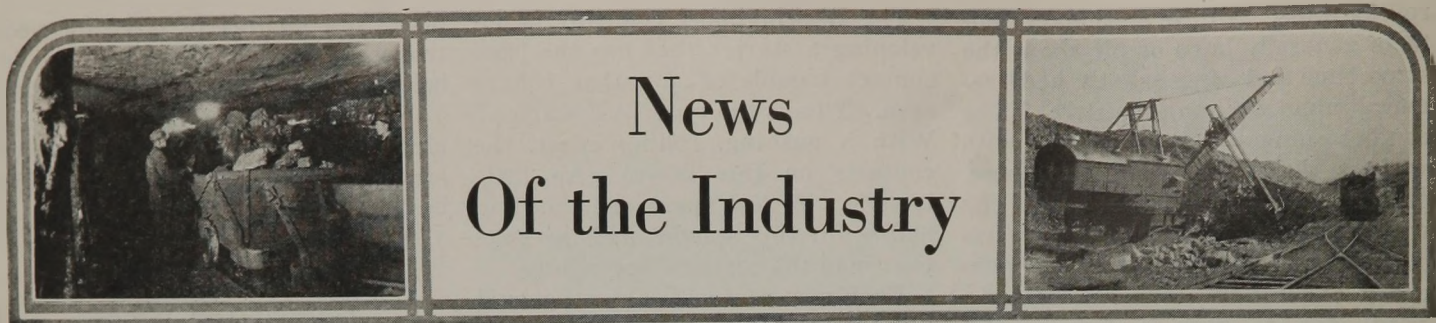

## Federated Union Flops to U. M. W. As Strike for Jacksonville Scale Fizzles at Pittsburgh Coal Co.

The Federated Miners' Union of Western Pennsylvania, which was formed among employees of the Pittsburgh Coal Co. in western Pennsylvania, where the company is operating on the 1917 scale, voted to disband on March 18 and affiliate its membership with the United Mine Workers after calling a strike of its members. This action followed the alleged refusal of the Pittsburgh Coal Co. to accede to the demands of the Federated for the restoration of the Jacksonville wage scale.

Last Thursday night, officials of the Pittsburgh Coal Co. announced that the strike call would have no effect on its working forces, and this was borne out Friday morning, when a total of 1,855 men reported for work in the eight mines working, which was 10 more men than had worked the day before, when the strike was called.

The Federated Miners' Union was formed at a meeting in Pittsburgh on Dec. 22, 1925. A disavowal of allegiance to the United Mine Workers was the high spot of the organization. W. T. Harris, of Whitsett, Pa., was elected president, and John L. Hoffman of Van Meter, Pa., secretary.

P. T. Fagan, president of District No. 5, United Mine Workers, has welcomed the members of the dissolved organization into his union with open arms.

In a statement, the Pittsburgh Coal Co. said:

"The majority of our miners had refused to join the Federated Miners' Union. Any influence which Mr. Harris may have had with these men will be lost when they learn that he has delivered the organization which he formed to the United Mine Workers.

"The action of Mr. Harris in causing to be absorbed in the United Mine Workers the organization which he had formed in mines which were strictly understood to be operating independent of the United Mine Workers speaks for itself.

"The men who passed the resolutions were in no way representative of the miners working for the Pittsburgh Coal Co.

"The Pittsburgh Coal Co. permitted the official of the Federated Miners' Union to attempt to organize that union in their mines in the belief that Mr. Harris was sincere and that the miners desired an independent union. Events have proved that they do not want another union nor to pay dues to such a union.

"There can be no better proof of the utter failure of the Federated Miners' Union and its entire lack of influence among the miners than in the answer to this alleged strike call."

Secretary Hoffman, of the Federated Union, in a statement said, among other things: "The company has refused permission to the officers of the union to take up grievances in behalf of employed members and to pay the rates for extra work provided in the 1917 wage scale."

On Saturday, March 20, the company announced there were 89 more men in the mines than on previous Saturdays. On the other hand, P. T. Fagan, president of District No. 5, United Mine Workers, said that at least 500 miners in the eight mines of the company had laid down their tools and joined the union.

### Ohio Operators Ask Cut In Union Wage Scale; Lewis to Defend Policy

A meeting of representatives of 200 coal operating companies in the Hocking Valley was held at Nelsonville, Ohio, on March 17 to devise ways and means of bringing about a reduction in the union wage scale in order that operations can be resumed at many of the mines in this section. Operators feel that unless a reduction is granted by the miners' union, the coming summer will see still further curtailment in production in the field. A committee consisting of Walter Wolf, Nelsonville; C. C. Sharp, Nelsonville; P. C. Morris, New York Coal Co.; N. D. Monserrat, Monserrat Bros., Columbus; O. C. Newton, Sunday Creek Coal Co., Columbus; G. S. Jones, Ohio Collieries Co., Toledo, and Dr. T. R. Biddle, Poston Consolidated Coal Co., Athens, was named to confer with John L. Lewis, president of the United Mine Workers, and other national officers in order, if possible, to obtain concessions in the scale.

Co-operation of the southeastern Ohio operators with those of the central and northern fields was recommended by W. H. Haskins, Coshocton, who reported an unsuccessful effort made by operators in the Coshocton field to get wage concessions.

The operators of the central and northern fields suggested to Mr. Lewis

a return to the \$5 per day wage for daymen and the selection of a central committee of miners and operators to sit in Indianapolis and telegraph prices of coal back to the mines until non-union competition of West Virginia and Kentucky was met. James R. Pritchard, formerly commissioner of the Southern Ohio Coal Exchange, desired that a conference be sought with President Lewis, believing that by such action responsibility for the future could be placed at the door of union officials.

#### Eastern Ohio Joins Movement

Eastern Ohio operators met at Bridgeport on March 20 and formally joined the movement to persuade the union to agree to accept a cut in wages from the Jacksonville agreement in order to meet competition from the non-union fields of West Virginia and Kentucky.

The James Paisley interests, of Cleveland, are reported to have sent a telegram to John L. Lewis, stating that unless concessions were allowed at once it would be necessary to close six mines of the company—three in Belmont County, Ohio, and the others in the union region near Morgantown, W. Va.

John L. Lewis is making a personal effort to stem the tide of dissension and rebellion against his stand-pat policy in the Pittsburgh district, advices from that field state. Philip Murray, international vice-president, recently conferred with representatives of the operators in the Ohio No. 8 field, at which time he was told of the serious plight of the Ohio operators who are bound by the Jacksonville scale. He was asked that the union do something to relieve the situation. It was at Mr. Murray's request that Mr. Lewis is taking an active personal part in the situation.

This is exactly the procedure followed a year ago, when a committee of Pittsburgh and Ohio operators requested a modification of the Jacksonville scale. Mr. Lewis at that time refused to consider the matter, and it is understood that he recently told Illinois and Indiana operators that he will give no consideration to such proposals.

The largest operator in the Pittsburgh district, the Pittsburgh Coal Co., which is running its mines on the November 1917 scale on an open-shop basis, has announced its intention of going ahead on that basis irrespective of what the union may do. A few of the mines in the Pittsburgh district that were able to operate and pay the Jacksonville scale during the anthracite strike have closed down. The Pittsburgh Terminal Coal Corp. is an exception and a few other properties are working a day or two a week.



## British Coal Commission's Report Favors Labor, Says U. S. Economist; Legislation Will Be Forthcoming

By Paul Wootton

Washington Correspondent of *Coal Age*

Although the British mine workers did not get all they asked, the report of the Royal Coal Commission, if a victory for anybody, is a victory for labor. The necessary legislation to put into effect the recommendations of the Commission is sure to be forthcoming, as Premier Baldwin is said to have given assurances that he would put through any program on which the Commission would agree unanimously.

These are the opinions of I. Lubin, of the economic staff of the Institute of Economics at Washington. He sat through the thirty-one days of public hearings before the Commission and kept in close contact with the leaders on both sides of the controversy. A report from an eyewitness is of particular interest in this country, as the recommendations in regard to royalties are likely to be reflected in demands on this side of the ocean.

There is no thought that the British are out of the woods as a result of this report. In fact, Mr. Lubin believes they are only entering the woods. Meanwhile there seems no escape from the continuance of the subsidy for an indefinite period. Prospects favor a continuance of indirect subsidy in the form of guaranteed loans to the operators.

### General Strike Now Unlikely

The only recommendation really displeasing to labor was that proposing to reduce the wages of some of the better paid workers. That some way will be found to prevent that recommendation from becoming effective is expected, although the mine workers no longer have the full sympathy of labor in other trades. They recently have lost ground materially in that direction. All danger of a general strike is believed past, although an effort to enforce the wage cuts probably would cause a walk-out with the prospect of support from the railroad and dock workers.

Valuation proceedings under the report necessarily will move very slowly. Existing leases will have to expire. For these reasons none of the benefits of the recommendations, except the wage reduction, will produce any immediate economies. In the long run, however, Mr. Lubin believes large efficiencies will be effected. In fixing the terms for new leases the government should be in a position to require the use of machines to any extent it desires. The high-cost operations might even be abandoned to a large extent and where they are essential the profitable seams might be made to pay the deficit.

All of the economies of consolidation can be effected. Large savings will be made through the use of common shafts and by systematic drainage plans. In one case, for instance, three seams, one above the other, are being worked through three separate shafts. Under the proposed plan the government will have the whip hand over such inefficient

operations. It will be able to put a stop to the extortions of land owners who collect large sums for running under their land, even when no coal is involved. Great savings will be effected in dictating the terms of the new leases.

The royalty owners will fight the proposed plan to the last ditch, but their opposition is certain to be overridden. The Church of England and the Duke of Northumberland are the two largest interests that will be affected and neither has the backing of public sentiment in wanting its speculative profits protected. There is no thought that royalty owners will not receive a fair price for the present valuation of their holdings.

Another heavy expense that will be saved under the new plan will be in the elimination of the so-called pioneer lease. New seams usually are opened by prospecting companies, which then lease them to regular operators. The plan contemplates breaking up the practice of railroad-car ownership by individual mines. Decided economies in transportation can be effected by drawing all wagons from a common pool.

Heretofore it has been thought the operators were not greatly concerned with what happened to the royalty owners, but the negotiations just concluded have revealed just what is in the hearts of the operators. Under the new plan their liberty of action will be greatly curtailed. The low-cost producers naturally opposed bitterly any plan of contributing to the support of the weak sisters. The operators, without success, tried to establish before the commission that machines are being used to the extent that they are profitable. They tried to belittle the economies of amalgamation and gave the impression throughout the hearing that they have no plan of their own other than lowering labor costs which would begin to meet the situation. Their objective apparently was to maintain as nearly as possible the existing status.

## Railway Fuel Men to Discuss Conservation Problems

The eighteenth annual convention of the International Railway Fuel Association will be held at the Hotel Sherman, Chicago, beginning May 8. The meeting will last three days, divided into seven sessions, at which a number of important papers and interesting committee reports will be presented.

Among the addresses on the program are the following: "Operating Factors in Fuel Conservation," by W. R. Scott, president, Southern Pacific Lines; "Engineering Factors in Fuel Conservation," H. R. Safford, vice-president, Missouri Pacific R. R.; "Mechanical Factors in Fuel Economy," C. E. Brooks, chief of motive power, Canadian National Rys. Other speakers will be President J. W. Dodge, superintendent of fuel conservation, Illinois Central R.R.; C. H. Markham, president, Illinois Central R. R.; M. L. Gould, president, National Coal Association, and Eugene McAuliffe, president, Union Pacific Coal Co., who will present the committee report on cooperation with the American Railway Association.

Committee reports will be made also on "Storage of Fuel and Oil," by Glenn Warner; "Inspection, Preparation and Analysis of Fuel," Malcolm Macfarlane, and "New Locomotive Economy Devices, Coal and Oil," E. E. Chapman.

## Merger of Mine Stations Meets Opposition

The proposal to consolidate experiment stations of the Bureau of Mines has produced a decided reaction throughout the West. A large number of letters are being received by the Bureau, some supporting this recommendation of the advisory committee and others in opposition to it. These letters are being analyzed carefully, and no action on the recommendation is likely before midsummer.

Secretary Hoover probably will confer again with the advisory committee before taking final action on that portion of the committee's report. The committee probably will not be called together until the return to this country of Chairman Reynders. He probably will not be back from the Caucasus before July 1.

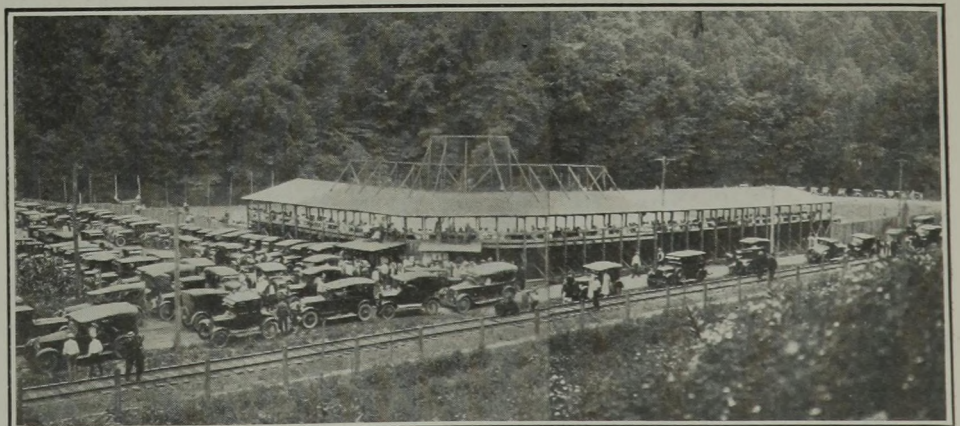

Baseball in the Mountains of West Virginia

This park is on the property of the Consolidation Coal Co., near Coalwood, McDowell County. The scene indicates that the life of a coal miner is not "all work and no play." Finding a level spot sufficiently large for a ball park often is very difficult in the mountain towns.



## Heavy Coal Output and Outlay for Modernization, U. S. Steel Report Shows

Coal produced by the United States Steel Corporation during 1925 totaled 31,475,568 tons as compared with 27,738,007 tons in the preceding year, in increase of 3,737,561 tons, says the pamphlet report of the Corporation made public March 22. Of this tonnage 23,692,607 tons was used in the manufacture of coke and 7,782,961 tons was used for steam, gas and all other purposes. In 1924 21,041,573 tons was used in the manufacture of coke and 6,696,434 tons for steam, gas and all other purposes.

The Corporation manufactured 3,289,905 tons of beehive coke and 13,011,319 tons of byproduct coke, a total of 16,301,224 tons, as compared with 14,408,041 tons in the preceding year.

The Corporation manufactured 3,289,905 tons of beehive coke and 13,011,319 tons of byproduct coke, a total of 16,301,224 tons, as compared with 14,408,041 tons in the preceding year. Expenditures on the Corporation's Pennsylvania coal properties for electrification aggregated \$1,008,263. Additional outlays covering a wide range of improvements were made in this field and in the Pocahontas, Kentucky and Illinois fields for modernizing and economizing the cost of operations, says the report. Purchases of sundry additional coal and timber areas were made in the Pennsylvania, Illinois and Alabama fields, at a total expenditure during the year of \$881,460.

The employees on the coal and coke properties of the Corporation numbered 25,920 during 1925 as compared with 26,054 in 1924, a decrease of 134.

The value of coal, coke and other fuel as inventoried on Dec. 25, 1925, was \$11,546,885 as compared with \$12,153,798 on Dec. 31, 1924.

The Corporation owns 438,354 acres (bed area) of coking coal, 320,495 acres (bed area) of steam and gas coal; 16,427 beehive coking ovens, of which 13,305 are active and the balance inactive, and 3,284 byproduct ovens.

## Engineers and Operators To Co-operate in Research

Co-operation of the mechanical and the mining engineers of the country, through their national organizations, with bituminous coal operators in research work designed to bring substantial benefits to coal producers and consumers is planned through a committee appointed last week consisting of Dr. H. Foster Bain, secretary, American Institute of Mining and Metallurgical Engineers; Harry L. Gandy, executive secretary, National Coal Association, and Calvin W. Rice, secretary, American Society of Mechanical Engineers. Walter Barnum, president of the Pacific Coast Coal Co., Seattle, Washington, was authorized to name this committee at a meeting in New York of officials of the two engineering societies and the National Coal Association.

The research program to be outlined by this committee will embrace the outstanding problems of the coal industry and will deal with the development of the mechanization of coal mines, which is a significant movement in the industry on the score of economic and social considerations, as well as from engineering and operating viewpoints.

## Hoover Cites Importance Of Foreign Trade

"The immediate purpose of those engaged in foreign trade is remunerative adventure for the trader," said Herbert Hoover, Secretary of Commerce, in an address at New York City, March 16. "But it has a far wider national importance than this and the men engaged in it are engaged in a far more significant mission.

"Foreign trade has become a vital part of the whole modern economic system. The war brought into high relief the utter dependence of the life of nations upon it. The major strategy of war is to crush the enemy by depriving him of it. In peace time our exports and imports are the margins upon which our wellbeing depends. The export of our surplus enables us to use in full our resources and energy. The creation of a wider range of customers to each production unit gives to that unit greater stability in production and greater security to the workers.

"And we may quite well view our exports from the other side of the trade balance sheet. They enable us to purchase and import those goods and raw materials which we cannot produce ourselves. We could probably get along as a nation if we had to suppress the 7 to 10 per cent of our production which goes to export but our standard of living and much of the joy of living is absolutely dependent upon certain import commodities."

## Railroads Save \$46,000,000 On Coal in 1925

The average cost, including freight charges, of coal used by class 1 railroads of the United States in locomotives in transportation train service during December was the same as during the preceding month, according to a statement prepared by the Bureau of Coal Economics of the National Coal Association from monthly reports furnished by the railroads to the Interstate Commerce Commission. The average cost by districts was as follows: Eastern district, \$2.66; Southern district, \$2.20; Western district, \$2.93; entire United States, \$2.63. In comparison with similar averages for December, 1924, there was a decrease of 20c. per ton in the Eastern district, 17c. per ton in the Southern district, 16c. in the Western district, and 19c. in the country as a whole.

The average cost per ton of locomotive coal, which represents the invoice price at the mine, plus freight charges, during the year 1925 was \$2.72 per net ton, a reduction of 31c. from the year 1924. As the railroads in the United States during the year 1925 consumed at least 150,000,000 tons of bituminous coal, it is apparent that the bituminous coal industry contributed the round sum of \$46,500,000 to the prosperity of the railroads during the past year.

## Grant to Address Retailers At New England Convention

Richard F. Grant, president of the Susquehanna Collieries Co. and the man who succeeded in bringing operators and striking miners together when all other efforts to end the anthracite strike had failed, will be the featured speaker at the annual convention of the New England Coal Dealers' Association to be held at Worcester, Mass., April 7-8. Mr. Grant will talk on "Clear Thinking."

Harry L. Gandy, executive secretary, National Coal Association, will make his debut before the New England retailers at the same convention. Another speaker will be C. Willing Hare, vice-president of the Anthracite Coal Service, who will match Mr. Gandy's bituminous address with a talk on what the anthracite industry is doing. "Loss and Damage Claims" will engage the attention of Col. A. N. Payne, of the Boston & Maine R.R. Harry E. Davis, national councilor of the New England association, will discuss the work of the Chamber of Commerce of the United States.

The headquarters of the association during the convention will be at the Hotel Bancroft, where the annual banquet, presided over by William A. Clark, president of the organization, will take place. The business sessions will be held at the State Armory.

## Research Study at Illinois

Applications for appointment to research graduate assistantships maintained by the Engineering Experiment Station of the University of Illinois will be received until April 1. Appointees receive an annual stipend of \$600 and freedom from all fees except matriculation and diploma fees, graduates of approved universities and technical schools who are prepared to undertake graduate study in engineering, physics or applied chemistry being eligible.

Research graduate assistants devote one-half time to engineering research and the remainder of their time to graduate study. The training they receive gives excellent preparation for engineering teaching, engineering research and the profession of engineering. Additional information may be obtained by addressing M. S. Ketchum, director, Engineering Experiment Station, University of Illinois, Urbana, Ill.

## Merritt to Address Retailers

The speakers at the banquet to be held in connection with the eighth annual sectional meeting of the New York State Coal Merchants Association, New York group, this evening (March 25) at the Hotel Pennsylvania, New York City, will be Walter Gordon Merritt, general counsel for the Anthracite Operators Conference, and Captain Irving O'Hay, U. S. A., retired. The meeting will open with a luncheon at 1 p.m. at which the speaker will be Martin King, of Alabama. The program for the business session to follow was printed in *Coal Age* of March 18 (p. 406).



## Comprehensive Program Arranged For American Mining Congress and Machinery Exposition at Cincinnati

All sails are set and the course plotted for the Cincinnati meeting of the American Mining Congress, May 24 to 29. As in former years the National Exposition of Coal Mining Equipment and Machinery—at which will be exhibited new and improved mine equipment of all kinds—will be staged in conjunction with the meeting. Operating officials and bosses representing every live coal company in the country, who will make the trip to Cincinnati this year for the big event, will find available a greater wealth of information than ever on developments in equipment and operating practices.

The meetings will be devoted to practical discussions of conveyors, loading machines, mine layouts, roof control, transportation with reference to track and mine-car design; cutting and shooting, drainage and safety problems, including rock-dusting and the sealing of mine fires.

The problems which will be discussed have been chosen by the operators themselves. The entire country was canvassed for suggestions as to topics and speakers, under the direction of Newell G. Alford, of Pittsburgh, who is secretary of the program committee. This committee is composed of operating officials from each of the major coal-mining states, headed by George B. Harrington, president of the Chicago, Wilmington & Franklin Coal Co., as chairman. A meeting of representatives of this committee was held in Pittsburgh on March 20, at which the returns of the canvass were reviewed. From them were chosen those topics which were thought to have the greatest appeal to the majority of those who will go to Cincinnati. In the absence of Mr. Harrington the meeting was presided over by Ezra Van Horn, general manager of the Clarkson Coal Mining Co., of Cleveland, Ohio.

### Will Discuss Drainage

The exposition will open on Monday, May 24, and the meeting on Tuesday, both continuing until Friday, May 29. The first session on Tuesday will deal with mine drainage, at which the following topics will be discussed: "Relation of Mine Drainage to Stream Pollution"; "Costs of Correcting and Rendering Harmless Drainage from Coal Mines"; "Economic and Legal Aspects of Stream Pollution"; "Restrictions of Stream Pollution." The chairman of this session will be Samuel A. Taylor, president of the American Institute of Mining & Metallurgical Engineers.

The Tuesday afternoon session will be devoted to the following topics on the cutting and blasting of coal: "Recent Experiences in Shearing and Blasting"; "Blasting Coal for Mechanical Loading—Cutting and Shooting Practices Designed to Facilitate Machine-Loading through Elimination of Refuse in Shot-Down Coal"; "Shooting with a Gas Cartridge"; "Results from Cushion Blasting." W. L. Affelder,

assistant to the president of the Hillman Coal & Coke Co., will preside at this session.

All day Wednesday will be assigned to mechanical loaders and their application. Under the chairmanship of Eugene McAuliffe, president of the Union Pacific Coal Co., the following topics will be discussed in the morning: "Progress in Mechanization of Coal Mines"; "Mechanical Loaders That Have Operated Successfully at the Face and Their Operating Costs"; "Typical Machine-Loading Failures and Reasons Therefor"; "Methods of Adapting Present Standard Mining Systems for Best Results with Mechanical Loading"; "Getting Mine Cars to and from Mechanical Loaders."

### To Study Machine Loaders

James Elwood Jones, general manager of the Pocahontas Fuel Co., has been chosen as chairman of the Wednesday afternoon session, at which these topics will be discussed: "Suggested Procedure for the Small Mine Investigating Possibilities of Machine Loading"; "Methods for Mining Thin, Flat Seams with Mechanical Equipment"; "Mechanical Loading in Rooms and Entries," including discussions of (a) "Driving Narrow Places in Thick Seams with Loading Machines" and (b) "Recent Developments in Machine Loading Equipment and Applications"; "A Symposium on Mechanical Brushing of Top and Bottom Rock in Entries."

The Thursday morning session, under Dr. L. E. Young, general manager of the Union Collieries Co., will cover the following problems of underground conveying: "Inside Mine Conveyors"; "Mechanical Conveying of Coal from the Face Which Has Reduced Mining Costs"; "Underground Conveyors in Use with Mechanical Loaders"; "Mining Plans for Different Types of Conveyors"; "Conveyors in Longwall Work—Adaptation of European Underground Conveyor Practice to American Mines."

Safety of mines will be the general theme of the Thursday afternoon session, with J. J. Rutledge, chief of the Maryland Department of Mines, as chairman. Rock-dusting and the sealing of mine fires will be covered by the following topics: "Proven Advantages of Rock-Dusting"; including discussions of (a) "Successful Application of Rock-Dusting" and (b) "Recent Manifestations of Rock Dust in Checking Coal Dust Explosions"; "Sealing Fires in Gaseous Mines." This general topic will be broken down into three parts: (a) "Current Practices," (b) "When the Fire Is Small" and (c) "Territory Required."

Howard N. Eavenson, consulting engineer, will preside over a session on Friday morning, at which the following topics on roof control and mining methods will be discussed: "Elements of Roof Control"; "Roof Control on Long Faces"; "Long Face Mining with

### Fuel-Oil Tax Disallowed In British Columbia

The coal mining industry of Vancouver Island in particular, and of British Columbia, as a whole, received a sharp setback on March 10 when Justice Morrison in the Supreme Court of British Columbia, pronounced the fuel-oil tax to be *ultra vires* (beyond power) of the provincial Legislature. In 1923 the provincial Legislature enacted a bill providing for the imposition of a tax of one-half cent per gallon on all fuel oil purchased in British Columbia, and the tax went into effect at the beginning of 1925. Though the tax ostensibly was enacted as a revenue measure, there is a belief in some quarters that it was brought forward at the behest of the mine operators and miners of Vancouver Island, who had been feeling keenly the competition of foreign fuel oil. The Canadian Pacific Ry. and the Union Steamship Co. of British Columbia, the two largest users of fuel oil in the Province, resisted the tax on the ground that it was illegal, whereupon the Attorney General brought action in the Supreme Court against the two companies to enforce payment.

Since the imposition of the tax the government has collected \$206,000 from it, but had the defendants in this case paid the tax it is said that more than \$400,000 would have been collected.

Jacks"; "Control of Roof in the Eagle Seam" (this seam, in West Virginia, is overlaid by a very rotten shale, than which few roofs are worse); "Recent Developments in Roof Control."

The last session, on Friday afternoon, will cover underground transportation. A. R. Beisel, general manager of the Island Creek Coal Co., will be asked to serve as chairman of this session, which will include the following topics: "Planning Track Layouts—Importance of Good Track"; "Track Work Details and Maintenance"; "Selecting a Mine Car Design"; "Control of Long Hauls—Electric Gathering and Haulage in General"; "Comparative Costs of Mule, Storage-Battery and Cable-Reel Gathering."

### All Will Hear Easily

Incidental arrangements are being made to alleviate some of the disadvantages of the ordinary convention. Speakers will be asked to deliver their talks from notes. Microphones will be installed to carry every word clearly to all corners of the convention hall. A film on rock-dusting which was taken by the Chicago, Wilmington & Franklin Coal Co. in its Orient No. 2 mine will be shown for the first time in public and a new film on mine safety, prepared by the Peabody Coal Co., also will be presented. An informal dinner will be held on Thursday evening, at which a prominent speaker will cover some important phase of the industry.



## Canadian Committee to Probe Coal Supplies

A special committee of the Dominion House of Commons will investigate Canadian supplies of anthracite and bituminous coal. A resolution by J. E. Armstrong, Conservative, of East Lambton, to this effect was adopted after a heated discussion March 17. There was reference to the coal movement from Alberta. Charles Stewart, Minister of the Interior, spoke of the recent conference on the freight rate on Alberta coal, remarking that the provinces seemed to be unable to agree on the matter.

T. L. Church, of Northwest Toronto, charged that Sir Henry Thornton, president of the Canadian National Rys., was one of those responsible for failure to get Canadian coal into the central Canadian markets. Mr. Church declared that the proposal to raise the rate for bringing Alberta coal to Ontario from \$7 to \$9 a ton was nothing but one more victory for "The American coal baron." Mr. Church urged an embargo on imported coal.

W. F. Maclean (Conservative, South York), advised Nova Scotia to nationalize her coal mines, cut the profiteering out of production and apply it to the reduction in the price of coal. He thought that Ontario and Quebec would be willing to make a contract for Nova Scotia if this suggestion was followed.

Charles Stewart, Minister of the Interior and Mines, said the government would welcome such an investigation because it would clear up many misapprehensions about the fuel situation. He was not sure that he could agree that the time had come to nationalize Canada's coal mines. It would be a solution for many problems if central Canada could be supplied with coal from eastern and western Canada. He pointed out that the development of water power in central Canada and also the growing tendency to use oil were cutting into the demand for coal.

## New Chicago Coal & Dock Co. Ready for Business

The South Chicago Coal & Dock Co., having offices at 39 South LaSalle St., Chicago, which was incorporated with a capital of \$750,000 a few weeks ago, will soon be in active operation. The company has purchased from the Hedstrom-Schenck Coal Co. its dock property at 95th St. and the Calumet River, having an area of 470,000 sq.ft., and will install modern coal-handling machinery. Avery Brundage is chairman of the board; D. S. Harding, president, and T. F. McCarthy, manager of sales.

The Great Lakes Transportation Co., Valley Camp Coal Co. and the George Hall Coal & Transportation Co. are allied with the new concern, guaranteeing it not only dependable sources of coal but also its transportation by water to Chicago. Subscribers, according to a statement by the company, include James Playfair, president of the Great Lakes Transportation Co. and the George Hall Coal & Transportation Co. and vice-president of the Valley Camp Coal Co.; James Paisley, presi-

## Trust Problem Looms as Tendency to Merge Grows

An increasing tendency on the part of American business to combine and consolidate gives evidence that this country is on the verge of a trust problem, and vastly adds to the labors of the Department of Justice, Assistant Attorney General E. F. Myers, told the House Appropriations Committee Feb. 26 in the course of hearings on the Department supply bill before the House Appropriations Committee.

"You can not pick up a paper without reading of some merger in business," he said. "And, as you know, unless it appear that the merger would result in restraint of trade within the decision in the steel case, or unless it is brought about by stock acquisition which results in elimination of competition between two companies within the meaning of Sec. 7 of the Clayton act, there is not now any legislation covering the situation.

"Whether the people of the country want Congress to provide against that sort of merger is something outside our province. I know that we have been criticized, but, with the arms at our command, I think we are doing everything the law enables us to do."

dent of the Valley Camp Coal Co., and C. W. Kraft, president of the Kraft Shipbuilding Co. and the Kraft Coal & Fueling Co.

## Canada Coke Output Mounts Slightly in January

Output of coke in Canada advanced to 155,700 short tons in January, 1926, as compared with 152,173 tons in December, and 101,132 tons during January, 1925, according to a report to the Department of Commerce from Assistant Trade Commissioner Walter J. Donnelly, Montreal. Ovens in the Providence of Ontario led with a total production of 74,655 tons followed by those of eastern Canada, which reported an output of 60,510 tons.

Imports of coke into Canada during January last totaled 114,724 tons as against 131,276 tons in December. Exports aggregated 3,237 tons, the apparent consumption in Canada during January being 267,187 tons, a decrease of about 4 per cent from the previous month, when 279,048 tons was used.

Of the 239,750 tons of bituminous coal used for coke making in January, 150,520 tons was imported, against the use of 89,230 tons of Canadian bituminous coal.

## Navy Seeks Coal Bids

Proposals for the supply of 2,000 net tons of run-of-mine bituminous coal for the naval air station at Pensacola, Fla., will be opened at noon April 1 by the Bureau of Supplies and Accounts, Navy Department, Washington, D. C.

## Three West Virginia Firms in \$2,500,000 Merger

Three West Virginia coal firms, the Blue Ridge Coal Co., of Brush Creek, Boone County; the Swiss-By-Product Coal Co., of Swiss, Nicholas County, and the Export Coal Co., of Quinimont, Fayette County, have been consolidated, according to an announcement made in Charleston on March 19. The new company will operate under the name of the Superior Fuels Co., and the capital stock will be \$2,500,000.

The combined production will aggregate 4,000 tons a day. The coal produced at the Blue Ridge plant will be disposed of to malleable iron and clay product plants; the output of the Swiss company mine will be consumed by yard interests in the northwest and the Export mine will ship its coal to consumers in New England. Those in charge of the consolidation say the entire output is already provided for.

T. S. Jones of Steubenville, Ohio, is president and J. Jay Ross, of Huntington, is the operating manager. A. D. Williams, former state highway commissioner of West Virginia, will be consulting engineer for the company, with offices in New York City. He conferred with the company officials in Charleston on March 19.

The addition of several Pennsylvania mines is said to be contemplated.

## Still No Illinois Machine Scale

A meeting of the joint committee of Illinois coal operators and representatives of the United Mine Workers was held at the Great Northern Hotel, Chicago, on March 17, for the purpose of working out an agreement on wages to be paid operators and helpers on loading machines. The meeting was of brief duration and no announcement was made at its conclusion except that another conference would be held at an early date.

## Eccles Inquest Postponed

The inquest on the explosion of March 8 at Mines Nos. 5 and 6 of the Crab Orchard Improvement Co., near Eccles, W. Va., has been postponed from March 24 to April 7 because of delay in cleaning up the mine. Sixty-five feet of concrete partition between intake and return airways was shattered by the explosion and ventilation has not been restored to more than a quarter of the mine, which probably will be in operation again in a month.

The Anthracite Operators' Conference on March 18 elected the following officers and committees for the coming year: Chairman, Samuel D. Warriner; Vice-Chairman, Danel T. Pierce; Committee on Economics, W. H. Williams, Allan C. Dodson, Thomas Dickson, G. N. Wilson, C. S. Goldsborough; Committee on Labor, W. J. Richards, C. F. Huber, W. W. Inglis, E. H. Suender, A. M. Fine; Committee on Publicity and Education, Percy C. Madeira, W. J. Richards, Eliot Farley, J. M. Humphrey, J. L. Cooney; Committee on Public Relations, W. S. Jenney, C. F. Huber, Otis Mouser, A. B. Jessup, S. B. Thorne.





## News Items From Field and Trade

### ALABAMA

The Chickasaw Shipbuilding & Car Co., a subsidiary of the Tennessee Coal, Iron & Railroad Co., is reported to have been awarded a contract for 1,000 hopper coal cars as its proportion of the recent heavy equipment contract let by the Southern Ry. The Birmingham plant of the Virginia Bridge Co. will build a large number of steel underframes also.

The Alabama By-Products Corporation is installing electric lights and water connections throughout its camp at Flat Creek, in the western part of Jefferson County. It is reported that the company will build a number of new dwellings for its employees at this operation.

Frank H. Crockard, president of the Woodward Iron Co.; Howard J. Thomas, general superintendent of the Sloss-Sheffield Steel & Iron Co., and Frank G. Morris, general superintendent of coal mines of the Republic Iron & Steel Co., compose the program committee for Alabama in the assignment of papers to be read before the Cincinnati meeting of the American Mining Congress, May 24 to 28. A large delegation of mining officials, mining and mechanical engineers and others interested in the mining industry from the Birmingham district will attend.

Two Joseph A. Holmes safety chapters were organized at Flat Top convict mine of the Sloss-Sheffield Steel & Iron Co. on March 14 by representatives of the U. S. Bureau of Mines, Alabama Mining Institute and State Mining Department at the request of the State Convict Board. The white chapter, which was named the Jones G. Moore Chapter, has 92 members, and the negro chapter, named the C. R. Davis Chapter, has 422 members.

### ARKANSAS

Owners of the Ohio mine, on Hall mountain, have installed pumping machinery and are pumping the water out of the mine in preparation for resumption of mining this spring.

The engine and boiler rooms of Western Coal & Mining Co. mine No. 6, at Denning, were blown up by dynamite early the morning of March 16. The mine had been operated since Aug. 4, 1925, under lease by C. L. Melton, with non-union labor. Ten sticks of dynamite, unexploded, were found beneath the cylinder of the shaft engine.

Fire, believed to have been of incendiary origin, destroyed the coal tipple, warehouse and several cars of

coal of the Bernice Anthracite Coal Co., at Russellville, last week with a loss of \$100,000.

### ILLINOIS

Mine No. 1 of the Chicago, Wilmington & Franklin Coal Co., known best as "Old Orient," and Mine No. 1 of the Bell & Zoller Coal Co., two of the largest in the southern Illinois field, have resumed operations after having been shut down for several weeks. Old Orient is located at West Frankfort and had been closed down for four weeks while undergoing repairs. It employs 1,000 men. The Bell & Zoller mine closed down apparently for the season several weeks ago. It will employ its 1,100 workers on a 40-per cent basis for the time being.

One of the largest operations in the Madison County district, the Lumaghi Coal Co. mine No. 2, at Collinsville, which employs about 1,200 men, is working only one day a week at present.

The shaft at the No. 1 mine of the Mt. Olive & Staunton Coal Co. caved in early this month, and as a result the hoisting tower is a wreck.

The Marion & Eastern R.R., a coal road from Marion to Paulton, a distance of 12.5 miles, is to be sold to the Missouri Pacific and operated as a part of that system. A contract for the sale has been entered into by the Missouri Pacific and H. E. Barber, principal owner of the Marion & Eastern. The Interstate Commerce Commission and the Illinois Commerce Commission will be asked to approve the transaction. The Marion & Eastern is about fifteen years old and had been operated profitably until recent months when the excessive cost of shipping coal over two roads forced several of the mines served by the road to cease operations. With direct rail facilities into the St. Louis market, however, it is expected that these mines will resume.

The Radium Coal Mining Co., Belleville, which is supposed to be a subsidiary of the Aluminum Ore Co., is expected to suspend operations April 1, unless the miners will permit the loading machines in the mine to operate the same as in other mines in that district, because the company can buy coal cheaper from the non-union West Kentucky fields than it can produce it.

The Lumaghi Coal Co., of St. Louis, is reported to have announced that it will give preference to the sale of non-union west Kentucky coal over that of its own union mines in Illinois.

### INDIANA

One hundred and eighty-six employees of the Old Knox Coal Mining Co., of Bicknell, now in the hands of a receiver, have filed suit in Circuit Court at Vincennes to foreclose workmen's compensation liens on the mine property to recover their wages for the last two weeks worked. The total indebtedness of the company to its employees is more than \$16,000.

### KANSAS

May 22 was selected as the date for the annual Kansas first-aid and mine-rescue meet at a meeting of operators, miners and state mine officials in Pittsburg, March 10. The meet will be held on the athletic field at the Kansas State Teachers' College, Pittsburg. Teams already are being organized.

Central Coal & Coke Co.'s mine No. 51, in the southeastern Kansas field, was closed March 12 as a result of the weak demand. The mine employed more than 300 men. The Central company now has only one shaft—No. 45—operating in Kansas.

### KENTUCKY

The Kentucky Legislature of 1926, which adjourned on March 17, treated the coal industry quite well. Bills to place a tonnage tax on coal, a washhouse act for mines, and other adverse legislation were killed in committees as a rule, or didn't get very far. One bill killed a few days ago provided for the creation of a boiler commission to inspect boilers, with a fee system to inspectors, which would have been costly to boiler owners, especially those who have insurance and obtain inspection as a part of the insurance service.

Through suit filed in the federal court at Hazard Judge Cochran on March 16 named John P. Gorman as receiver for the Kentucky River Coal Mining Co., operating at Heiner.

Politicians have been making a hard fight in the U. S. Coal & Coke Co.'s privately owned town of Lynch, in Harlan County, a bill having been introduced in the Legislature to force incorporation of the city, on the ground that the company controls the votes of its workers, numbering several thousand.

The Elk Horn Coal Corporation had a record production of 2,082,408 tons and the highest net income since 1920 of \$311,802, equal to \$2.37 a share (par \$50) on \$6,600,000 preferred stock in 1925. Output was 774,322 tons, or



60 per cent above 1924 and 628,182 tons, or 43 per cent above the previous record year of 1920, and net income compared with 38,445, equal to 29c. a share on preferred in 1924. With 401,271 tons mined by lessees, total tonnage produced from Elk Horn properties in 1925 was 2,483,679 tons, compared with 301,524 tons mined by lessees and aggregate tonnage of 1,618,612 tons in 1924.

In western Kentucky the Monro Warrior interests have plans for a big new power house, and additional equipment at both strip and underground mines for getting out larger production at smaller cost.

It is reported from eastern Kentucky that the Elkhorn, Jr., Coal Co., at Millstone, is completing a modern new tippie and installing other equipment for larger production.

J. L. McCormick, of the Mineral Development Co., of Philadelphia, recently was in eastern Kentucky, inspecting company properties in Letcher County, but no announcement was made regarding any development plans.

The Dawson Daylight Coal Co., of Louisville and Dawson Springs, organized three or four years ago and running coal from strip mines for more than a year, has rebuilt a burned tippie, and also is developing some underground mines to reach coal in the deeper veins and not practical to mine by stripping.

## MISSOURI

Howard & Sons, of Prairie Hill, are to open up a mine near Salisbury soon. A 4-ft. seam of coal, within a mile and a half of Salisbury on the Wabash Glasgow branch, is to be mined. Workmen are busy sinking a 154-ft. shaft. Howard & Sons subleased the property from R. E. Davis, of Salisbury.

St. Louis coal men are working on plans for a Coal Research Bureau in an educational campaign to present to the public facts about coal as a fuel and to develop other measures that will give to the coal user information as to proper sizes and consuming conditions.

## OHIO

M. S. Connors, general manager of the Hocking Valley Railway Co., announces that 2,700 loaded cars of coal are at Walbridge, adjacent to the Toledo docks on his road waiting for the resumption of loading for lake traffic. Ample bottoms to take care of this tonnage have been tied up at the Toledo docks during the winter and these will be loaded ready to move when navigation is opened. It was feared that the recent cold spell might cause the formation of additional ice in the upper passages, but reports show that conditions are good and it is believed that lake traffic can be opened to the head of the lakes by April 15, which is the tentative date set for the opening.

The North Hill Coal Co. has closed its mine near Chauncey, which gave employment to about 150 miners. The mine will remain closed until market conditions warrant its reopening.



Homes of Employees of the Kingston Pocahontas Coal Co., W. Va.

This inviting location affords the employees of the Kingston Pocahontas company's Exeter Collieries a delightful environment for their homes. The buildings are of brick construction and modern in every respect.

## PENNSYLVANIA

At the Pennsylvania Coal Mining Institute meeting in Johnstown on March 19, Edward H. Johnson, mining engineer, of Columbus, Ohio, delivered an address on mechanical mining and loading. His lecture was illustrated with lantern slides. The annual banquet will be held on May 20. Archie Miller, Loyalhanna Coal Co. superintendent at Cairnbrook, was elected president, succeeding Charles Enzian, of the Berwind-White company, of Windber. William Flemming, of Riverside was re-elected secretary and F. J. McKernan was retained as his assistant. The vice-presidents are D. J. Boyle, Penn Public Service Corp., Johnstown; B. C. Leonard, South Fork; Nicholas Evans, Johnstown; A. C. Cook, Windber. Vincent Stanton of Johnstown is treasurer.

The Westmoreland Coal Co. for the year ended Dec. 31, 1925, reports surplus of \$745,728 after charges, taxes, depreciation and depletion, equal to \$3.73 a share earned on \$10,000,000 capital stock (par \$50). This compares with \$38,520, or 19c. a share, in 1924.

Joseph J. Walsh, Secretary of the Department of Mines, has announced a special examination for candidates for appointment as anthracite mine inspectors to be held at Wilkes-Barre on March 30, 31 and April 1. The special examinations are to be held because none of those who took examinations recently qualified for inspector. At the present time there are seven inspectorships in the anthracite region vacant.

James M. Black, Ellsworth, has been appointed a mine inspector in the State Workmen's Insurance Fund board, Richard H. Lansburgh, Secretary of the Department of Labor and Industry, has announced. The work has to do with the insurance plan. The appointee is not an anthracite or a bituminous mine inspector.

In the will of the late Mrs. Eckley B. Coxe, known as the "angel of the coal fields," further provision was made for the future of the Freeland Mining and Mechanical Institute. This institute was founded by Mr. Coxe with

the idea of giving miners' sons a chance to rise in the world. When it first opened there were only four students enrolled. Now there are 170. Prof. W. R. Bray, formerly of Lehigh University, is in charge of the Freeland institute.

George J. Cochran, of Johnstown, a stockholder in the Conemaugh Coal Mining Corp., on March 6 petitioned the court at Ebensburg for the appointment of a receiver for the company. The court named the Johnstown Trust Co., the Title Trust and Guarantee Co. and Attorney John H. Stephens. In his bill Mr. Cochran sets forth that in an effort to finance the company certain indebtedness is about due; that if payment of this indebtedness is pressed at this time it will necessitate the closing of the mines, with great loss to the stockholders. He believes receivers will be able to put the company on a firm financial basis.

The Pittsburgh Coal Co. reports a new peak in weekly output from the eight mines in western Pennsylvania working on the 1917 scale. In the week ended March 13 a total of 36,246 tons was produced. A maximum daily production of 6,668 tons was attained during the week.

The report on Pittsburgh river transportation for February by United States Engineers shows that 1,469,004 tons of coal was moved on the Monongahela River in addition to 33,465 tons of coke; on the Ohio River in this district, 152,994 tons of coal and on the Allegheny River, 13,900 tons of coal.

Injunction proceedings were instituted March 18 at Washington, Pa., against the Pittsburgh Terminal Coal Corp., of Pittsburgh in which it was charged that the company permitted dangerous practices at a mine near Avella, known as Meadowlands No. 1. The action was brought in the name of the state through Attorney General George W. Woodruff and Mine Inspectors P. J. Callaghan, John J. McDonald and John F. Bell. Hauling of coal by locomotive operated by an electrical



trolley in portions of the mine known to be gaseous, specified as Butts Nos. 27, 28 and 29, and promiscuous firing of shots without observance of the requirements of the state mining laws are specifically charged. The mine employs about 400.

The Hazle Brook Coal Co. has announced that a new breaker will be erected on the company's properties at Tremont. It is expected the breaker will have a capacity of 1,000 tons of coal daily.

Wilkes-Barre school officials are making a survey of local conditions to determine whether a sufficient number of mine workers are interested in the establishment of a mining school there. If the survey indicates enough students will enroll the school board intends to organize classes immediately.

Acme No. 1 and No. 2 mines of the Bethlehem Mines Corporation, located on the M. & W. branch of the Pennsylvania R.R. between Monongahela and Bentleyville, are to reopen soon after being closed more than a year. Approximately 1,000 men will be employed. As the corporation pays the 1917 wage scale, it is expected these mines will open on the same basis.

Judge Dailey at Huntington, last week appointed Andrew S. Webb and Walter L. Haehnlen, of Philadelphia, temporary receivers for the Huntington & Broad Top Mountain Railroad & Coal Co.

The Hazelkirk and Ellsworth No. 2 mines of the Bethlehem Mines Corporation will be opened within the next 30 days, according to plans of the company.

## TENNESSEE

The Marion Coal Mining Co., of Chattanooga, has leased 3,000 acres of land between Whiteside and Shellmound and will develop it.

## UTAH

The Sweet Coal Co. reports that its mine in the Gordon Creek district of Carbon County, now being developed, contains coal of an excellent coking quality. The seam is reported to be 9½ ft. thick. A number of tests have been made and at present a Chicago concern is making an oven test. The company recently constructed a small beehive oven at the mine for the purpose of carrying on experiments. Utah has so far developed but two coal properties of coking quality, one at Sunnyside by the Utah Fuel Co., and the other by the Utah Steel Corp.

The Consumers' Mutual Coal Co. has awarded the Pittsburgh Boiler & Machine Co. a contract for building a tiple at its mine in Carbon County. The structure will be of steel with a capacity of 4,000 tons in eight hours. It will be equipped to handle all grades of coal. The contract must be completed in five months, a bond having been given guaranteeing this.

The Spring Canyon Coal Co., with offices in Salt Lake City, has started an action for an accounting of funds in connection with its workmen's compensation insurance with the State Compensation Fund up to the time it be-

came its own insurer. It is held that the company is entitled to certain dividends. Officials in charge of the fund have announced their intention of filing a cross-suit asking for the return of dividends already paid, thereby, they say, testing the law at both ends.

## VIRGINIA

Three suits growing out of operations of the Tidewater Coal Exchange at Norfolk during and immediately after the close of the World War have been brought in the U. S. District Court in Norfolk by Andrew W. Mellon, as director general of the American railroads. The suits are against three local coal concerns, then members of the exchange. The New River Coal Co. is sued for \$7,500; West Virginia Coal, \$5,000; Eastern Coal & Export Corporation, \$5,000. The suits are for the purpose of clearing up disputes over demurrage claims of long standing.

The Virginia Fuel Corporation, of South Norfolk, manufacturers of "Certified Coal" briquets, made from half soft coal and half anthracite slack, has shipped its first cargoes abroad, consisting of three small lots consigned to England. The company has obtained a through rate to New England, and is now working its plant to the full capacity of 15 cars a day for the first time since it began operating.

## WEST VIRGINIA

Reports were current in southern West Virginia last week that eastern capitalists are making an effort to purchase the old Hartford City property at Clifton, Mason County, consisting of an old salt mill, a quantity of coal land and 350 acres of surface.

The Camp Fork Coal Co., which recently was organized by G. R. Krebs, of Charleston, and others, has acquired the Greendale mine of the Concordia Coal Co., at Greendale, Nicholas County, and will operate it to take care of the summer trade.

The mine of the Davis Creek Land & Coal Co. on Davis creek in the Kanawha field has closed down.

The H. T. W. Coal Co. of Huntington, has increased its capitalization from \$20,000 to \$50,000.

Loss estimated at several thousand dollars was sustained when a blaze believed to have originated from a short-circuit destroyed the carpenter shop and electrical repair shop at the Kingmont mine of the Hite interests, at Fairmont, March 13.

Directors of the Island Creek Coal Co. on March 17 declared a dividend of \$4 a share on the common stock and the regular quarterly dividend of \$1.75 a share on the preferred stock. On Jan. 1 last a dividend of \$5 a share was paid on the common stock.

Coal production in West Virginia in 1925 totaled 125,434,130 tons, an increase of 21,451,128 tons over 1924, according to figures made public by A. O. Wilson, statistician of the Kanawha Coal Operators' Association.

Output in southern West Virginia, the statistics showed, aggregated 87,642,551 tons, an increase of 16,050,588 tons com-

pared to 1924, while in the northern part of the state the output was 30,691,534 tons, an increase of 5,400,540 tons compared to 1924.

The Consolidation Coal Co. reports total earnings of \$19,839,109 in 1925 against \$19,263,184 in 1924. After allowing for all expenses and charges for depreciation, depletion and interest the net profit was \$225,606, against a loss of \$2,125,650, after similar deductions, in 1924. The profit for 1925 was equal to \$2.25 a share earned on the \$10,000,000 7 per cent. preferred stock outstanding. The surplus carried to profit and loss was \$50,606. During the year the company and its lessees mined 10,794,903 tons of coal, compared with 10,075,068 in 1924.

## CANADA

The United British American Coal Co., of Vancouver, has acquired 900 acres of coal lands at Deep Valley, 4½ miles from Princeton, B. C., and has started to develop the property.

The Canadian Pacific Ry. has placed an order for 400,000 tons of coal with the McGillivray Creek Coal & Coke Co., and is negotiating with other operators in the Crows Nest Pass district of British Columbia for a further supply.

The North Pacific Forests & Mines has been organized to take over and develop the Slate Chuck coal mine and surrounding timber limits, situated at Skidegate Inlet, Queen Charlotte Islands, B. C.

The South Okanagan Collieries, near Princeton, B. C., which had been idle for some time, has re-started development work, new capital having been obtained in Vancouver.

In its annual report for the year ended Dec. 31, 1925, the International Coal & Coke Co. reports operating profits of \$124,659, in addition to sundry profits of \$18,008, or a total of \$142,667. This record compares with an operating loss of \$9,582 in the preceding year. During the last year the company's mine in Alberta worked 156 days, employing an average of 344 men. Total production was 178,542 tons.

Miners at the Minto Coal Co.'s mines at Minto, N. B., have gone on strike, and the mines are completely closed. The strike arose from the failure of the company to accept a new wage agreement outlined by the miners.

A scheme of unemployment relief for the 470 families at Sydney Mines, N. S., who are suffering as a result of prolonged inactivity of the collieries, is being undertaken by the town, the Canadian Government, and the Provincial government. All three bodies will grant equal shares.

Intense excitement prevails at Port Simpson, B. C., where the Indians are said to have discovered an outcropping of coal on the reserve. The whole property has been staked and steps taken to record it. No work on it has been done yet, but the Indians are very hopeful. The whole of the United Church mission property is included in the blocked-out area. Port Simpson is on the British Columbia coast at the mouth of the Skeena River, south of Prince Rupert.



## Personal

J. O. Colley has been appointed superintendent of the Flat Creek Division of the Alabama By-Products Corp. coal mining operations, succeeding Edmund Ewing. Frank House, former superintendent of the Porter Coal Co., at Porter Mine, has been made superintendent of the Alabama By-Products Corp.'s Praco operations. He was succeeded at Porter Mine by John Rutledge. W. C. Paxton has been appointed superintendent for the State of Alabama at Banner Mines, of the Alabama By-Products Corp., where convict labor is employed.

B. M. Chaplin, well-known coal operator of Morgantown, W. Va., who has just returned from a six weeks business sojourn in Florida, has decided to locate in Florida and engage in the contracting and construction business. Mr. Chaplin has long been identified with the Chaplin Collieries Co.

James L. Davidson, secretary of the Alabama Mining Institute and prominent industrialist, was named on the board of governors at the recent meeting in Memphis of the southern division of the American Mining Congress.

W. P. Barrick recently resigned as superintendent of the Macbeth (W. Va.) mine of the Thurmond Consolidated Coal Co.

H. A. McAllister recently resigned as manager of the Logan (W. Va.) division of the West Virginia Coal & Coke Co.

P. C. Thomas, assistant general manager of the Helen (W. Va.) mine of the East Gulf Coal Co., which was absorbed by the Massachusetts Gas Co., has resigned.

Sandy Marshall, superintendent of the Monitor and Yuma Coal & Coke Cos., at Wilkinson, Logan County, W. Va., resigned recently.

John Sincock, of Uniontown, Pa., who has for several years been general superintendent for W. J. Rainey, Inc., operating six of the largest coal and coke plants in the Connellsville coke region, has resigned that position, to take effect at once. Mr. Sincock will be retained by the Rainey company as consulting mining engineer. No statement has been made as yet as to who will succeed Mr. Sincock as general superintendent, but the place is being filled temporarily from the New York office.

William Heitzman, who for the past six years has been general western sales manager for the Central Pocahontas Coal Co., has resigned effective April 1 to go into the real estate business in Cincinnati, where he has large holdings. He has been succeeded by S. E. Butler, who has been in charge of the Detroit office of the company for the past five years.

Howard Stutchbury, Industrial Commissioner of Alberta, has returned to Alberta following a month spent in Eastern Canada in an endeavor to promote the use of Alberta coal. Mr. Stutchbury advocates an extensive campaign on the part of the Alberta Government to popularize Alberta coal in Ontario and eastern Canada.



W. M. Wilshire

William M. Wilshire, recently elected president of the West Virginia Coal & Coke Co., as successor to C. E. Hutchinson, who resigned, will make his headquarters in Cincinnati, it is said.

## Obituary

Lochren Donnelly, general superintendent of the coal-mining operations of the Northwest Improvement Co. at Colstrip, Mont., died March 17 at Glendive, Mont., after a short illness of heart disease. He was 29 years old. Mr. Donnelly was the son of Charles Donnelly, of St. Paul, Minn., president of the Northern Pacific Ry., which controls the Northwest Improvement Co. The younger Mr. Donnelly had been connected with the organization for about six years and had been in charge of the mining operations for two years. Burial took place in Seattle, Wash.

## Traffic

### Central Pennsylvania Accepts Challenge on Rates

Central Pennsylvania coal operators have accepted the challenge of the southern West Virginia, Virginia and eastern Kentucky coal operators in the matter of freight rates. The Southern operators have petitioned the Interstate Commerce Commission to reopen Docket No. 15006, originally begun as an investigation into and concerning anthracite rates and which later by order of the Commission was made to include rates on bituminous coal from Southern coal fields to all-rail destinations in Northeastern states.

By order of the Commission certain rates were temporarily established from mines in the Southern fields to the above-named destinations. These rates were to expire April 30, 1926. The Commission stated these rates were to take care of an emergency due to the anthracite strike. The so-called emergency is now passed and certain interests in New England are asking that the rates be made permanent and be extended to all sizes of coal, mine-run and slack as well as prepared sizes for household fuel, to which the temporary rates only applied.

In the answer made by central Pennsylvania coal operators to the petitions

of New England and the Southern coal fields it is contended:

(1) That the combination rates in effect on Southern coal previous to the temporary rates are not unjust or unreasonable and should be maintained on Southern coal.

(2) That the temporary rates were established to take care of an emergency without full and complete hearings. There now exists no reason why these rates should be extended as the anthracite strike has been settled, and if extended would involve the Commission in a breach of faith, relied upon by the central Pennsylvania operators in good faith that these rates would be temporary rates only.

After asking for a denial of the petitions of the New England interests and the Southern coal operators, the central Pennsylvania operators say:

"Protestant prays also that should the Commission grant further hearing in this proceeding, such further investigation and hearing should embrace by appropriate supplemental orders of the Commission, the reasonableness, the relation, and the propriety and lawfulness otherwise of all rates, including tidewater transshipment rates, on bituminous coal from all producing districts in Pennsylvania, Maryland, West Virginia, Virginia and eastern Kentucky to all destinations in Virginia, the District of Columbia, and in the Middle Atlantic and New England states."

### Suspend Proposed Rate Changes From Illinois Mines

By an order entered March 6 in Investigation and Suspension Docket No. 2621, the Interstate Commerce Commission suspended from March 8, 1926, and later dates until July 6, 1926, the operation of certain schedules as published in tariffs issued by various carriers publishing rates on coal from Illinois mines and Lake Superior ports.

The suspended schedules propose to increase rates on bituminous coal from Illinois to destinations in Minnesota on the Minnesota Western R.R. and to reduce rates on bituminous coal from Lake Superior ports to the same destinations. The following rates in cents per net ton are illustrative:

To	Present	Proposed
Lake Lillian, Minn.		
From		
Duluth, Minn.	303	261
Springfield, Ill.	404	441
Herring, Ill.	434	471

### Penna.-Ohio Operators File Briefs in Lake Case

Briefs in behalf of the Pennsylvania and Ohio bituminous coal operators who are seeking a reopening of the lake cargo case have been filed with the Interstate Commerce Commission. Opponents have ten days in which to reply, after which the Commission will take the application for reopening under advisement. Operators from the southern fields opposing an increase in the freight rate differential, and hence opposed to reopening the case which was decided in their favor last year, met in Washington March 15 in a conference over the situation, with particular reference to division of the expense of defending the case.



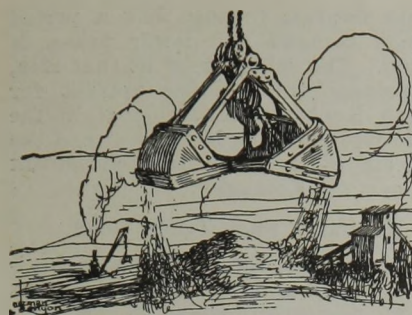

# Production And the Market

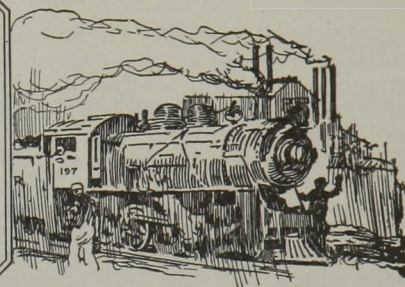

## Union Fields Move to Meet Non-Union Competition In New Coal Year; Contracting Lags

The labor situation again has assumed a commanding position in the bituminous coal trade of the country. That and the indifferent success attending the attempts of producers to hurry contract renewals far overshadow the superficial developments in spot trading as the coal year draws to a close. These developments have nothing to distinguish them from the season-end changes and minor upsets of other years.

The labor situation is pressing forward on two separate fronts. In Illinois and Indiana interest centers about the program of certain large producers to sell non-union western Kentucky coal in markets in which they have heretofore put tonnage from their own mines. This movement, initiated by the Peabody Coal Co., is, it seems, to be followed by two other—and possibly more—well-known operators in Illinois and Indiana.

In this change of front, the operators in question are duplicating a policy followed by certain producers in Ohio and Pennsylvania, who have tried to meet non-union competition by becoming non-union operators or sales agents. Ohio, however, is now going a step further and is reviving the campaign to force a downward revision of the Jacksonville scale. Unless this is done, the union is warned, there will be further indefinite suspensions at union operations.

### Fight Shy of Contracts

While these struggles are in the formulative stages, producers elsewhere are redoubling their efforts to persuade consumers to renew contracts. Some business, notably that of the Norfolk & Western, has been closed at approximately last year's basis. For the most part, however, buyers are pursuing their traditional policy of waiting. In the East they have been fortified in this

campaign by the large tonnage of slack available while demand for bituminous lump and egg was heavy and by the distress tonnage seeking a purchaser after the anthracite strike ended.

A suspicion that some of the canny purchasing agents have been further improving their position by buying up low-priced coal at the mines is strengthened by the production estimates for the week ended March 13. The total output that week, according to the Bureau of Mines, was 10,691,000 net tons, an increase of 231,000 tons over the preceding week. This was the first check in the decline which set in two months ago.

### Prices Well Stabilized?

On the whole, the price situation appears to be fairly well stabilized—particularly in the Middle West. Pool quotations along the Atlantic seaboard also are less wobbly than a few weeks ago. This degree of stabilization is probably due to the fact that in most cases spot quotations have sunk as low as possible with safety to the seller. *Coal Age* Index of spot bituminous prices on March 22 was 167 and the corresponding price was \$2.02.

Anthracite demand is broadening. Production the second week of the month totaled 1,966,000 net tons, as compared with the pre-strike average of 1,825,000 tons. Chestnut still leads in popularity, with stove and egg contending for second place. Pea also enjoys a good demand, which is made more apparent by the fact that the mines have no storage piles to draw on to fill orders.

The Connellsville coke market is featureless. There is little call for spot furnace coke and less disposition to hurry into the negotiation of second quarter contracts. Foundry coke has been in moderate demand.

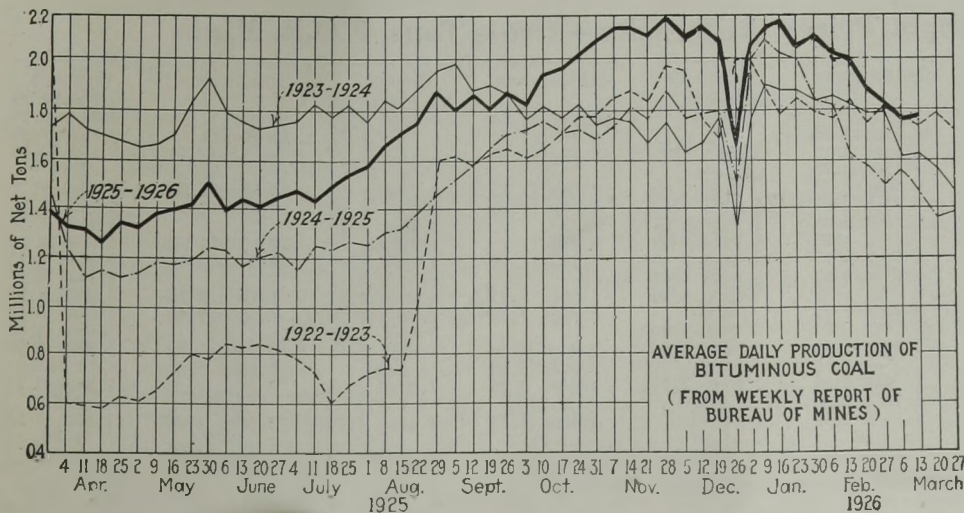

### Estimates of Production

(Net Tons)		
BITUMINOUS		
	1925	1926
Feb. 27	8,855,000	10,890,000
March 6 (a)	9,384,000	10,460,000
March 13 (b)	8,641,000	10,691,000
Daily average	1,440,000	1,782,000
Coal yr. to date	(c) 451,531,000	515,743,000
Daily av. to date	1,548,000	1,764,000
ANTHRACITE		
Feb. 27	1,605,000	1,609,000
March 6 (a)	1,655,000	1,789,000
March 13	1,656,000	1,966,000
Coal yr. to date	(c) 82,474,000	46,488,000
BEEHIVE COKE		
March 6 (a)	281,000	262,000
March 13 (b)	243,000	264,000
Cal. yr. to date	(c) 2,668,000	3,309,000

(a) Revised since last report. (b) Subject to revision. (c) Adjusted to equalize number of days in the two years.



**Non-Union Coals Gain in Middle West**

Day by day trading in the markets of the Middle West at the present time attracts less attention than the plans being made for handling business in the future. The most significant development is the proposal of Illinois and Indiana operators to go into the jobbing of non-union coals upon a large scale. The Peabody contract to handle the output of a number of western Kentucky mines was the first open move in that direction. At least two other well-known producers have made similar arrangements. Their theory is that the biggest job confronting them is to hold their customers; if they cannot do it with coal from their own mines they propose to do it with cheaper coal from non-union mines.

The adoption of such a policy, of course, means further shutdowns in the Illinois and Indiana districts. Current spot movement for the past few days has been confined largely to domestic coals. The weather has been the key

to this movement. Nevertheless, "no bills" can be found in all fields. Standard prices, however, have been well maintained; the greatest uncertainty is in quotations on stripping coal for railroad business. Contract buyers, for the most part, still turn deaf ears to pleas for early renewal of expiring agreements.

Local domestic trade at both Chicago and St. Louis was more active last week as a result of weather demand. Retailers generally are more interested in cleaning up stocks on hand than in ordering forward fresh supplies. As for some time past, smokeless coal is in slight demand at St. Louis and the resumption of hard-coal mining has brought no sharp call for anthracite tonnage. An increasing percentage of the lump trade in the St. Louis territory is going to western Kentucky.

Kentucky operators and sales agencies are pressing reluctant industrial consumers to close 1926-27 contracts. Some buyers fight shy of renewing at

the old figures, feeling that a period of slack demand and lower prices is at hand. The sellers scoff at that idea, emphasizing the broader market for western Kentucky all-rail coal in the Middle West and the Northwest and the prospects of a heavy lake movement from eastern Kentucky.

**Kentucky Spot Trade Good**

On the whole, the current spot business has been good. Cold weather has kept up domestic demand in odd lots; curtailed production has kept up prices on screenings and mine-run has shown unusual strength. Some choice eastern Kentucky block still is quoted at \$3 or better, but the general range is \$2@ \$2.75, with 2-in. lump at \$2@ \$2.25; nut and egg, \$1.75@ \$2. Western Kentucky block is \$1.75@ \$2; egg and lump, \$1.50 @ \$1.75; nut, \$1.35@ \$1.50; mine-run, \$1.10@ \$1.50; screenings, 85c. @ \$1.

Compared with February, shipments from the docks at the Head of the Lakes have fallen off. The movement,

**Current Quotations—Spot Prices, Bituminous Coal—Net Tons, F.O.B. Mines**

Low-Volatile, Eastern	Market Quoted	Mar. 23,	Mar. 8,	Mar. 15,	Mar. 22,	Midwest	Market Quoted	Mar. 23,	Mar. 8,	Mar. 15,	Mar. 22,
		1925	1926	1926	1926†			1925	1926	1926	1926†
Smokeless lump.....	Columbus....	\$3.10	\$3.85	\$3.85	<i>\$3.25@ \$3.50</i>	Franklin, Ill. lump.....	Chicago.....	\$2.75	\$3.00	\$3.00	\$3.00
Smokeless mine run.....	Columbus....	1.90	2.10	2.10	2.00@ 2.25	Franklin, Ill. mine run.....	Chicago.....	2.35	2.40	2.40	2.35@ 2.50
Smokeless screenings.....	Columbus....	1.15	1.15	1.15	1.00@ 1.35	Franklin, Ill. screenings....	Chicago.....	1.95	1.65	1.85	1.75@ 2.00
Smokeless lump.....	Chicago.....	3.10	3.75	3.10	3.00@ 3.25	Central, Ill. lump.....	Chicago.....	2.35	2.60	2.60	2.50@ 2.75
Smokeless mine run.....	Chicago.....	1.75	1.95	1.95	1.75@ 2.15	Central, Ill. mine run.....	Chicago.....	2.20	2.10	2.10	2.00@ 2.25
Smokeless lump.....	Cincinnati..	3.25	4.00	3.60	<i>3.00@ 3.50</i>	Central, Ill. screenings....	Chicago.....	1.90	1.40	1.40	1.35@ 1.50
Smokeless mine run.....	Cincinnati..	2.00	2.10	2.25	2.25	Ind. 4th Vein lump.....	Chicago.....	2.60	2.85	2.75	2.50@ 3.00
Smokeless screenings.....	Cincinnati..	1.50	1.30	1.35	1.25@ 1.50	Ind. 4th Vein mine run.....	Chicago.....	2.35	2.30	2.20	2.10@ 2.35
*Smokeless mine run.....	Boston.....	4.35	4.45	4.45	<i>4.30@ 4.50</i>	Ind. 4th Vein screenings..	Chicago.....	1.95	1.70	1.70	1.65@ 1.75
Clearfield mine run.....	Boston.....	1.95	1.95	2.05	1.85@ 2.25	Ind. 5th Vein lump.....	Chicago.....	2.30	2.15	2.15	2.00@ 2.35
Cambria mine run.....	Boston.....	2.30	2.30	2.35	<i>2.10@ 2.50</i>	Ind. 5th Vein mine run.....	Chicago.....	2.10	1.95	1.95	1.85@ 2.10
Somerset mine run.....	Boston.....	2.10	2.05	2.15	<i>1.90@ 2.35</i>	Ind. 5th Vein screenings..	Chicago.....	1.80	1.30	1.30	1.25@ 1.35
Pool 1 (Navy Standard) ..	New York...	2.65	2.85	2.80	<b>2.75@ 3.00</b>	Mt. Olive lump.....	St. Louis....	2.85	2.75	2.75	2.75
Pool 1 (Navy Standard) ..	Philadelphia..	2.65	2.80	2.80	2.65@ 3.00	Mt. Olive mine run.....	St. Louis....	2.35	2.15	2.15	2.15
Pool 1 (Navy Standard) ..	Baltimore....	2.10	2.25	2.10	2.10@ 2.15	Mt. Olive screenings....	St. Louis....	1.75	1.40	1.40	1.40
Pool 9 (Super. Low Vol.) ..	New York...	2.05	2.30	2.25	<b>2.20 @ 2.50</b>	Standard lump.....	St. Louis....	2.35	2.50	2.50	2.50
Pool 9 (Super. Low Vol.) ..	Philadelphia..	2.00	2.35	2.35	2.20@ 2.50	Standard mine run.....	St. Louis....	1.80	1.80	1.80	1.75@ 1.85
Pool 9 (Super. Low Vol.) ..	Baltimore....	1.85	2.10	2.05	<i>1.95@ 2.05</i>	Standard screenings....	St. Louis....	1.60	1.15	1.15	1.10@ 1.25
Pool 10 (H.Gr.Low Vol.) ..	New York...	1.80	2.00	1.95	1.80@ 2.10	West Ky. block.....	Louisville..	1.85	1.85	1.85	1.75@ 2.00
Pool 10 (H.Gr.Low Vol.) ..	Philadelphia..	1.65	2.05	2.05	1.90@ 2.25	West Ky. mine run.....	Louisville..	1.35	1.35	1.35	1.15@ 1.60
Pool 10 (H.Gr.Low Vol.) ..	Baltimore....	1.75	1.85	1.80	1.75@ 1.85	West Ky. screenings....	Louisville..	1.25	.90	.95	.85@ 1.10
Pool 11 (Low Vol.).....	New York...	1.55	1.85	1.75	<i>1.55@ 1.90</i>	West Ky. block.....	Chicago.....	1.85	1.75	1.75	1.65@ 1.85
Pool 11 (Low Vol.).....	Philadelphia..	1.55	1.80	1.80	1.75@ 1.85	West Ky. mine run.....	Chicago.....	1.25	1.50	1.15	.80 1.50
Pool 11 (Low Vol.).....	Baltimore....	1.50	1.75	1.65	1.65@ 1.70						

High-Volatile, Eastern		South and Southwest			
Pool 54-64 (Gas and St.)..	New York...	1.50	1.60	1.50	1.40@ 1.60
Pool 54-64 (Gas and St.)..	Philadelphia..	1.45	1.45	1.45	1.35@ 1.55
Pool 54-64 (Gas and St.)..	Baltimore....	1.70	1.55	1.55	<i>1.35@ 1.40</i>
Pittsburgh so'd gas.....	Pittsburgh...	2.40	2.45	2.45	2.40@ 2.50
Pittsburgh gas mine run ..	Pittsburgh...	2.00	2.10	2.05	2.00@ 2.15
Pittsburgh mine run (St.)..	Pittsburgh...	1.80	2.05	2.00	2.00
Pittsburgh slack (Gas)....	Pittsburgh...	1.35	1.25	1.45	1.40@ 1.50
Kanawha lump.....	Columbus....	2.10	2.10	2.05	<b>1.85@ 2.35</b>
Kanawha mine run.....	Columbus....	1.50	1.55	1.55	1.40@ 1.70
Kanawha screenings.....	Columbus....	.80	.70	.70	<b>.75@ .95</b>
W. Va. lump.....	Cincinnati..	2.10	2.25	2.15	<i>1.85@ 2.25</i>
W. Va. gas mine run.....	Cincinnati..	1.40	1.50	1.50	1.40@ 1.60
W. Va. steam mine run....	Cincinnati..	1.30	1.35	1.35	1.25@ 1.50
W. Va. screenings.....	Cincinnati..	.90	.85	1.00	<i>.75@ 1.00</i>
Hooking lump.....	Columbus....	2.35	2.50	2.50	2.25@ 2.75
Hooking mine run.....	Columbus....	1.45	1.50	1.50	1.35@ 1.70
Hooking screenings.....	Columbus....	1.05	1.05	1.05	1.00@ 1.15
Pitta. No. 8 lump.....	Cleveland....	2.30	2.40	2.25	1.90@ 2.65
Pitta. No. 8 mine run.....	Cleveland....	1.80	1.85	1.85	1.85@ 1.90
Pitta. No. 8 screenings....	Cleveland....	1.35	1.25	1.35	1.30@ 1.40

\* Gross tons, f.o.b. vessel, Hampton Roads.  
† Advances over previous week shown in heavy type; declines in italics.

**Current Quotations—Spot Prices, Anthracite—Gross Tons, F.O.B. Mines**

	Market Quoted	Freight Rates	—March 23, 1925—		—March 15, 1926—		—March 22, 1926†—	
			Independent	Company	Independent	Company	Independent	Company
Broken.....	New York.....	\$2.34		\$8.00@ \$9.25		\$8.25@ \$9.25		\$8.25@ \$9.25
Broken.....	Philadelphia..	2.39		9.15		9.00@ 9.25		9.00@ 9.25
Egg.....	New York.....	2.34	\$8.25@ \$8.50	8.25@ 9.25	\$9.00@ 12.50	9.00@ 9.25	\$9.00@ 12.50	9.00@ 9.25
Egg.....	Philadelphia..	2.39	8.65@ 9.15	8.80@ 9.25	9.25@ 11.50	8.75@ 9.25	<b>10.25@ 11.25</b>	8.75@ 9.25
Egg.....	Chicago*	5.06	8.17@ 8.40	8.08	9.25@ 12.50	9.15@ 9.25	9.25@ 12.50	9.15@ 9.25
Stove.....	New York.....	2.34	8.50@ 8.75	8.50@ 9.50	9.60@ 11.75	8.13	8.13	8.13
Stove.....	Philadelphia..	2.39	8.90@ 9.65	9.15@ 9.50	9.25@ 9.50	9.25@ 9.50	<b>10.50 @ 11.50</b>	9.25@ 9.50
Stove.....	Chicago*	5.06	8.80@ 9.00	8.53@ 8.65	9.60@ 12.50	9.35@ 9.50	9.60@ 12.50	9.35@ 9.50
Chestnut.....	New York.....	2.34	8.50@ 8.75	8.25@ 9.40	9.25@ 11.75	8.33@ 8.58	8.33@ 8.58	8.33@ 8.58
Chestnut.....	Philadelphia..	2.39	8.90@ 9.65	9.25@ 9.40	9.25@ 12.50	8.75@ 9.15	<b>10.50 @ 11.50</b>	8.75@ 9.15
Chestnut.....	Chicago*	5.06	8.61@ 9.00	8.40@ 8.41	9.00@ 9.15	9.00@ 9.15	9.25@ 12.50	9.00@ 9.15
Pea.....	New York.....	2.22	4.25@ 5.00	5.25@ 6.00	6.00@ 8.25	8.33@ 8.53	<b>7.50 @ 8.25</b>	8.33@ 8.53
Pea.....	Philadelphia..	2.14	4.75@ 5.75	6.00	6.00@ 6.35	6.00@ 6.50	<b>6.50@ 7.50</b>	6.00@ 6.35
Pea.....	Chicago*	4.79	5.36@ 5.75	5.36@ 5.95	6.50@ 7.50	6.00@ 6.50	6.50@ 7.50	6.00@ 6.50
Buckwheat No. 1.....	New York.....	2.22	2.00@ 2.75	2.50@ 3.00	2.50@ 3.50	5.65@ 5.80	2.75@ 3.25	5.65@ 5.80
Buckwheat No. 1.....	Philadelphia..	2.14	2.25@ 3.00	3.00	3.00@ 3.50	3.00@ 3.50	2.75@ 3.25	3.00@ 3.50
Rice.....	New York.....	2.22	1.90@ 2.25	2.00@ 2.25	2.00@ 2.25	3.00	3.00@ 3.50	3.00
Rice.....	Philadelphia..	2.14	1.70@ 2.25	2.25	2.00@ 2.25	2.25	1.85@ 2.25	2.00@ 2.25
Barley.....	New York.....	2.22	1.35@ 1.50	1.50	1.50@ 1.75	1.60@ 1.75	1.50@ 1.75	1.60@ 1.75
Barley.....	Philadelphia..	2.14	1.50	1.50	1.75	1.75	1.75	1.75
Birdseye.....	New York.....	2.22	1.40@ 1.60	1.60		2.00	1.40@ 1.60	2.00

\* Net tons, f.o.b. mines. † Advances over previous week shown in heavy type; declines in italics.



however, is large enough to convince operators that they will enter the new shipping season with no great surplus on hand. Stocks as of March 1 were officially reported at 2,875,000 tons of bituminous and 17,000 tons of anthracite, as compared with 2,818,000 and 255,000 tons, respectively, a year ago. It is estimated that stocks will be reduced to approximately 2,000,000 tons by the opening of navigation.

**Smokeless Weaker at Superior-Duluth**

Smokeless coals, which had the call during the anthracite strike, are weakening. Dock quotations on lump, egg and nut have been shaded 50c. and it is reported that some coal can be had at figures still lower. Mine-run and slack, on the other hand, are strong at \$5.25 and \$4.25. The bituminous list, too, is unchanged. There is considerable diversity of opinion as to how much of the hard-coal business smokeless will be able to hold next year. Dealers have been anxious to get anthracite, but the effect of the price differential between the two coals has not yet been measured.

Unusually cold weather has helped the domestic trade in the Twin Cities, but most of the buying is of the hand-to-mouth variety. Some all-rail anthracite has been shipped to St. Paul and Minneapolis. The steam coal trade is draggy. Receipts of anthracite at Milwaukee are increasing slowly and they are still insufficient to meet the brisk demand from householders. There also is a good call for all grades of bituminous coal despite moderate weather.

As the market in the Southwest grows weaker, more shaft mines in Kansas are closing down and crusher activity at the stripping operations is growing. Much of the business ordinarily taken care of by shaft-mine screenings is now going to crusher mine-run. Lump prices range from \$4 to \$4.50; screenings and crushed mine-run are firm at \$2.50. Little improvement in Arkansas production is expected before the summer storage season starts.

**Far Western Domestic Trade Drags**

Unseasonably mild weather in Missouri River territory has had a disastrous effect upon domestic demand at Colorado mines. Operations have been cut to a 50 per cent basis. Another factor in holding back orders has been the reduction in list prices which went into effect on Monday of this week. The weather also has taken toll of lump business in Utah. Large lump is now quoted at \$4, the same price asked for 3-in. coal; the former price was \$4.50. Screened slack has been advanced from \$2 to \$2.25 and straight slack from \$1.25 to \$1.50.

In the Cincinnati market the annual contest between lake buyers and producers is running true to form. After trying to beat down a \$1.50 figure to \$1.35@1.40, however, these buyers are swinging into line. They also are showing interest in slack at \$1. The fact that the Norfolk & Western Ry. has renewed its contracts upon practically the same basis as last year has had a tonic effect upon the situation. Cold weather and reduced production, too, are helping.

The low-volatile shippers still are

trying to readjust themselves to changed conditions. A \$3 quotation on lump and egg now is forecast for April business. Nut has slumped to \$2.50, but mine-run holds at \$2.25. How to raise slack to a point where it will carry more of its share of the cost load is a problem. Current quotations range from \$1.25 to \$1.50.

**Struggle to Move Prepared Coals**

It is a struggle to move prepared low-volatile coals. Some of the large Logan County producers have cut lump to \$2 and shrewd buyers are able to shade that 15c. Hazard lump is \$2@ \$2.25. Egg is extremely soft. Steam business, however, helps the mine-run situation and byproduct coals are stronger. Slack, on the other hand, has lost some of its recent firmness and some fair grades can be bought around 75c.

Movement of coal through the Cincinnati gateway, according to the latest weekly report of the American Railway Association, totaled 10,971 cars, an increase of 488 cars over the preceding week and a gain of 2,157 cars over last year. The largest increase was on the Louisville & Nashville—364 cars; the Norfolk & Western was second with an increase of 111 cars. A

heavier movement of empties to L. & N. mines brought the empty interchange to 17,084 cars, an increase of 728 cars over the preceding week.

River business has been excellent. For April delivery it is understood that the retail trade will ask \$8.50 for smokeless lump, \$5.75@ \$6 for mine-run, \$5.75@ \$6.25 for bituminous lump.

**Central Ohio Steam Trade Puzzles**

To a certain extent the steam trade in central Ohio is an enigma. General industrial conditions seem to have improved, but demand for coal has not reflected any increase. The contract outlook is uncertain. Railroads have asked for bids on substantial tonnages, but no awards have been made. Certain other large consumers also have made contract inquiries, but many are still out of the market. In the spot market there is a better tone to screenings—due solely to decreased production.

Weather, of course, is the controlling factor in the domestic trade. March retail business has been above the average, but wholesale buying has been in small lots. Consumer buying, too, has been for limited quantities. Smokeless is retailing at \$9.50@ \$10; West Virginia splint and Kentucky block, \$7@ \$7.50; southern Ohio, \$6@ \$6.50.

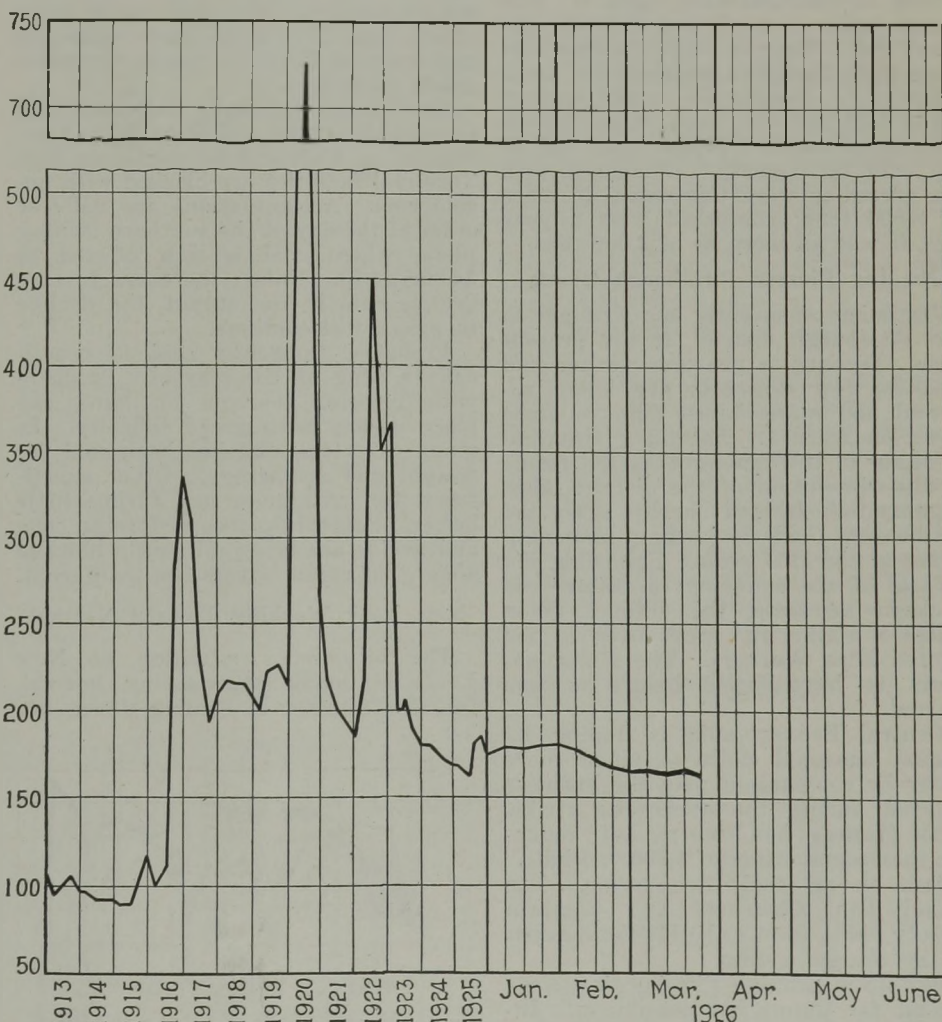

**Coal Age Index of Spot Prices of Bituminous Coal F.O.B. Mines**

Index	1926				1925	1924
	Mar. 22	Mar. 15	Mar. 8	Mar. 1	Mar. 23	Mar. 24
Weighted average price	167	168	167	169	163	176
	\$2.02	\$2.03	\$2.02	\$2.04	\$1.97	\$2.13

This diagram shows the relative, not the actual, prices on fourteen coals, representative of nearly 90 per cent of the bituminous output of the United States, weighted first with respect to the proportions each of slack, prepared and run-of-mine normally shipped, and second, with respect to the tonnage of each normally produced. The average thus obtained was compared with the average of the twelve months ended June, 1914, as 100, after the manner adopted in the report on "Prices of Coal and Coke: 1913-1918," published by the Geological Survey and the War Industries Board.



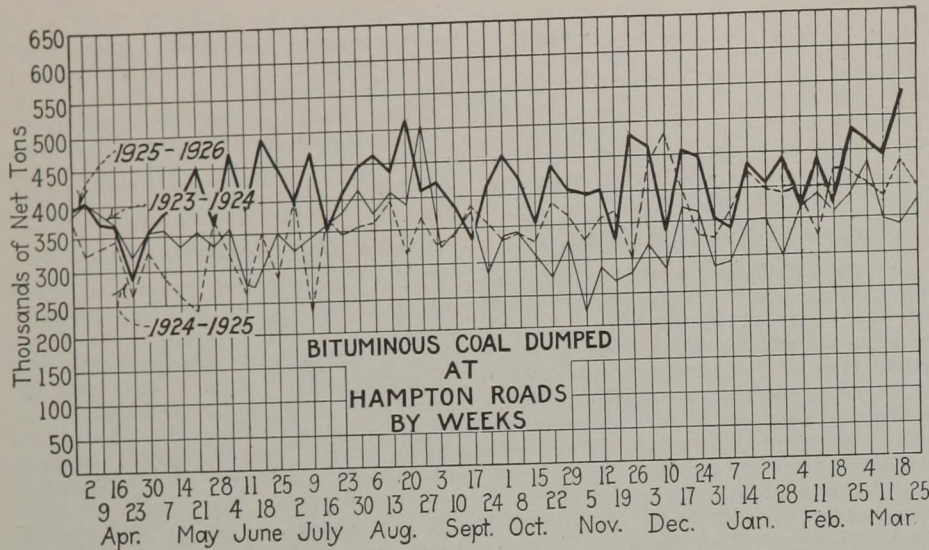

Southern Ohio production again has declined. No increase is looked for until the lake season is in swing. A considerable tonnage already has been loaded in bottoms tied up at the lower ports awaiting the opening of navigation.

There has been no change in spot prices in the Cleveland market. The steam trade is weak and domestic demand dull. There is more distress tonnage to be had than inquiries for fresh shipments. Production in the eastern Ohio field for the week ended March 13 approximated 250,000 tons, or 36 per cent of capacity. Compared with the preceding week this was a decrease of 8,000 tons; compared with a year ago, it was an increase of 4,000 tons.

**No Joy Pierces Pittsburgh Gloom**

Optimism apparently is a stranger to the Pittsburgh district at the present time. Demand is growing weaker and weaker; few contracts are being renewed and more mines plan to close down on April 1. The labor situation is again in the limelight as the result of the dissolution of the district labor organization formed shortly after the Pittsburgh Coal Co. began reopening mines at the 1917 scale. Following the refusal of the company to restore the Jacksonville scale, the defunct union called a strike and went over to the United Mine Workers. The strike appears to have failed before it was started.

Central Pennsylvania is finding its annual seasonal dullness made more bitter by comparison with the business enjoyed during the anthracite strike. Little progress has been made in reducing the accumulation of 1,800 "no bills." Prices on all coals are easier. The Broad Top, Clearfield and Cambria County fields seem to be hit the hardest in the present slump.

Buffalo is running Pittsburgh a close second for unrelieved pessimism. Industrial spot buying is niggardly. Cold weather has given some aid to distributors of domestic bituminous, but most of the demand from householders is for anthracite, which is now coming in in quantities sufficient to meet requirements. Aside from a scarcity of nut, Toronto retailers are experiencing no difficulty in taking care of orders for hard coal. Demand for low-volatile bituminous and coke has dropped.

**No Improvement in New England**

The New England steam coal market is not only sluggish; it is distinctly weak. Spot buying is slow and the few orders placed are for small tonnages. Spasmodic efforts have been made to interest consumers in contracts and it was rumored last week that certain public utilities were on the point of closing. The price most commonly mentioned is \$1.75 net, mines, for high-grade smokeless.

Spot prices on Navy Standard coal on cars at Boston and Providence have sagged to \$5.70@5.85 per gross ton. Terminal facilities are blocked with unsold coal. Accumulations are still the order of the day at the southern loading piers, where coal is now offered at \$4.30@4.50. Unless there are further drastic cuts in the output, the decline in prices will continue.

Prepared smokeless coal is practically a drug on the market. Shippers with rejected tonnage on hand can place it only with great difficulty. In many cases the coal has been sold for freight and demurrage. Other substitutes for anthracite are faring little better. Several cargoes of foreign coke and ovoids are being diligently hawked about, but retail buyers are indifferent.

**New York Working Toward Normal**

The bituminous situation at New York is slowly approaching normal. Distress tonnage is coming down, but

there still are about 4,000 cars standing at the piers. Spot buying, except of distress coal, is not brisk either at tide-water or in the line trade. Contracting, too, is backward, although some business has been closed at figures approximating those carried in last year's agreements. On contract some shippers are quoting pool 9 at \$2.05@2.25; pool 71, \$2.40@2.50 and pool 1, \$2.75@3. Late last week, however, it was reported that 125,000 tons of pool 9 quality had been closed at \$1.70.

Philadelphia sales agencies are endeavoring, with no great success, to induce steam buyers to sign on the dotted line for next year and to take a little extra tonnage on the expiring agreement. Leading factors say they are holding to \$2.65@2.75 on contracts, but there have been a number of offers of good trade coal at less. The railroads have bought so much bargain-counter tonnage since the anthracite strike ended that they are as reluctant as the general industrial consumer to tie up on contracts for the new season.

Conditions at Baltimore differ in no important detail from those now controlling at New York and Philadelphia. Few inquiries looking toward contract renewals have been made by the buyers. The poorer grades of steam coal are a drug on the spot market and the better grades are only in fair demand. All gas coals are sluggish. The only ray of immediate hope is in the faint revival of export movement.

**Birmingham Has Weather Flurry**

A sudden drop in the thermometer was responsible for a brief buying flurry in the Birmingham domestic market last week. Producers expect to announce their spring prices within a few days and contracting on a liberal scale is forecast. It is rumored that the new schedules will show some advances in the contract prices of the better grade coals.

Black Creek, Cahaba washed and mine-run and other standard grades from the Warrior field are still in good demand for industrial, coking and bunker fuel. Shipments against contracts continue heavy, with the railroads and public utilities taking their maximum quotas. Poorer grades are less active and mines producing such coal are curtailing their output.

Reduction in the tonnage of "substi-

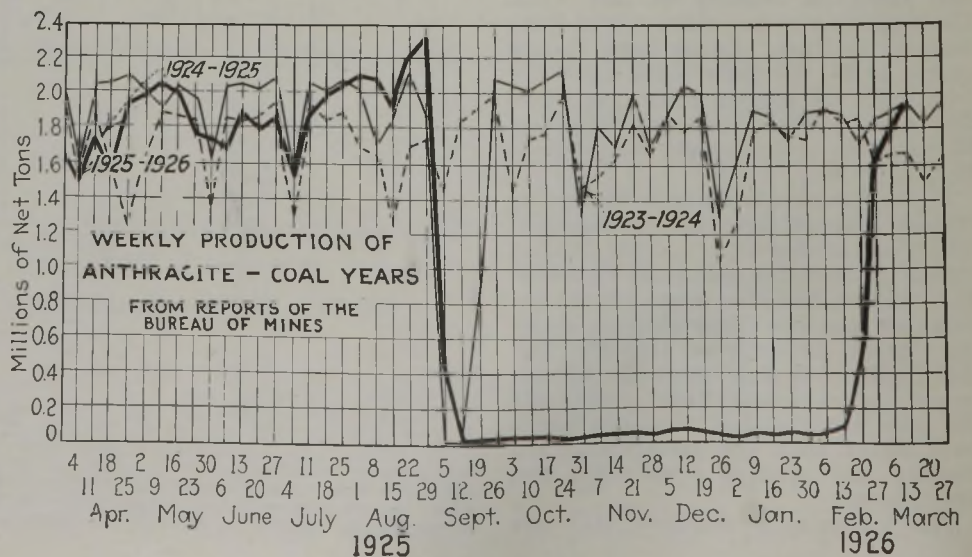



**Car Loadings and Supply**

	Cars Loaded—		Car Shortages
	All Cars	Coal Cars	
Week ended March 6, 1926.....	964,681	182,441	
Preceding week.....	912,658	180,434	
Week ended March 7, 1925.....	930,009	163,533	
	Surplus Cars—		Car Shortages
	All Cars	Coal Cars	
March 8, 1926..	202,432	72,949	
Feb. 28, 1926..	207,683	74,151	
March 7, 1925..	279,430	138,045	

tute" fuels in New York retail yards has increased the demand for anthracite in the metropolitan district. Old line companies are prorating their output among customers who have not felt the urge to buy large quantities of independent tonnage. This has prevented large premiums on the latter coal as the demand is just sufficient to keep prices steady.

**Chestnut Leads in Demand**

Most independent shippers are pressing buyers to take either egg or stove with chestnut. The last named size still leads in demand. Stove lags behind egg, which is growing stronger. Pea coal is moved without difficulty—an unusual situation for this time of the year. The steam coals are holding firm.

Complaint of insufficient receipts of anthracite is common in the Philadelphia market. Most of the coal is moved out of the retail yards as fast as it is unloaded. As at New York, chestnut is leading in popularity. Egg, however, is outranked by stove, but retail dealers accept it unhesitatingly. Pea, too, is enjoying an unwonted demand and there are no storage piles at the mines to quiet appeals for speedy shipment.

The steam market is absorbing the production sent to Philadelphia—but there is no excess of demand. On the contrary, there is evidence that some of the tonnage is coming from the breakers faster than the consumers throughout the anthracite steam-coal area as a whole are willing to take it.

At Baltimore the situation is still one of demand exceeding the supply because the retailers are adhering to their refusal to augment company shipments with purchases of high-premium inde-

pendent anthracite. Retail prices are on a pre-strike basis, which excludes paying \$12@ \$15 at the mines for coal.

**Connellsville Output Tobogganing**

Week by week the Connellsville ovens are continuing their efforts to bring beehive coke output in line with consumer requirements. During the week ended March 13, according to the Connellsville *Courier*, furnace oven production was cut 2,300 tons and merchant oven output 8,260 tons. The total production for the week was 188,990 tons, of which 100,400 tons came from furnace ovens.

Blast furnaces have shown little interest in the market and there is not much second-quarter business in the offing. Ovens talk \$3.50 for furnace coke and the furnacemen talk \$3.25. Spot tonnage is to be had at the latter figure. Foundry coke has been in moderate demand, with standard tonnage at \$4.50@ \$5. A fair run of buying by miscellaneous consumers also has helped the market.

**Railroads Use Less Fuel Oil During 1925**

A total of 59,355,000 barrels of fuel oil was consumed by locomotives of the principal railroads in the United States in 1925, compared with 61,738,000 barrels in 1924, according to returns received from railroads by the American Petroleum Institute. These figures include fuel oil consumed in all classes of service.

The largest consumption of fuel oil was shown in the Middle Western and Southwestern district, totaling 27,386,000 barrels in 1925 compared with 29,153,000 barrels in 1924. Consumption in the Southwestern Pacific district totaled 22,940,000 barrels in 1925 compared with 23,924,000 barrels in 1924. In the Northwestern district 6,637,000 barrels were consumed in 1925 compared with 7,060,000 barrels in 1924. In the Southern district locomotives consumed 2,278,000 barrels in 1925, compared with 1,470,000 barrels in 1924. In the Eastern district the consumption totaled 114,000 barrels, compared with 131,000 barrels in 1924.

**Canada's Coal Output and Consumption Drop in 1925**

Canada's consumption of coal during 1925 fell short of the level of the previous two years and amounted to only 90 per cent of the average for the five years 1920-24 inclusive, according to figures recently prepared by the Dominion Bureau of Statistics and received in the U. S. Department of Commerce. Of a total of 29,000,000 net tons made available for consumption last year almost half is accounted for by domestic production.

Nova Scotia led in the mining of bituminous coal with 3,800,000 tons, followed by British Columbia with 2,700,000 and Alberta with 2,100,000. Alberta also produced 3,200,000 tons of lignite and 570,000 tons of sub-bituminous coal. Labor troubles occasioned by strikes were given as the cause of production falling below the 1924 total and the average for the preceding four years. Nova Scotia, which suffered particularly in this respect, had a yearly output amounting to only 64 per cent of the average for the period 1920-24.

Exports also experienced a decline to 786,000 tons, or 45 per cent of the five-year average for 1920-24.

**Utilities Consume Less Coal But More Oil in January**

Public utility power plants in the United States consumed 3,738,006 net tons of coal in January, compared with 3,801,372 tons in the preceding month and 3,471,524 tons in November, according to the U. S. Geological Survey. Fuel-oil consumption by utilities in January totaled 1,016,316 barrels, as against 811,777 barrels in the preceding month and 790,734 barrels in November.

The average daily production of electricity by electric public-utility power plants in January was 197,300,000 kw.-hr., a little less than the revised daily rate for December but nearly 10 per cent larger than the output for January, 1925. The amount produced by the use of water power was 15 per cent larger and the amount produced by fuel power was 7 per cent larger.

**Bituminous Coal Produced by Stripping Operations In the United States in 1924\***

State	Number of Strip Pits	Number of Shovels	Net Tons Mined by Stripping	Total Net Tons Produced (same mines)	Underground—			Total	Days Worked	Per Cent of State Total Mined by Stripping	
					Total Value (all coal)	Miners, Loaders, etc., (a)	All Others				
Alabama.....	10	19	370,081	643,440	\$1,456,657	269	110	608	987	183	1.9
Arkansas.....	10	16	223,307	223,307	793,406	...	...	398	398	123	15.4
Georgia.....	1	2	65,657	72,947	267,063	53	18	68	139	250	87.6
Illinois.....	17	42	2,295,860	2,376,325	4,385,362	87	28	888	1,003	183	3.4
Indiana.....	27	57	2,511,189	2,511,189	4,995,889	...	...	1,537	1,537	159	11.7
Kansas.....	26	33	795,074	795,074	2,124,413	...	...	601	601	119	18.7
Kentucky.....	13	30	1,300,855	1,321,413	2,031,662	25	10	746	781	164	2.9
Missouri.....	19	27	979,700	979,700	2,730,487	...	...	814	814	132	39.5
North Dakota.....	13	9	434,184	445,509	955,835	17	4	231	252	171	36.2
Ohio.....	46	99	2,866,683	2,941,650	4,733,869	180	57	1,730	1,967	141	9.4
Oklahoma.....	13	21	312,109	319,609	1,159,753	31	8	382	421	177	13.4
Pennsylvania.....	31	54	902,818	1,509,728	2,910,476	392	132	870	1,394	177	0.7
West Virginia.....	4	7	244,448	244,448	348,694	...	...	94	94	152	0.2
Other states (b).....	4	4	304,989	309,889	598,117	7	2	55	64	224	3.2
Total.....	234	420	13,606,954	14,694,228	\$29,491,683	1,061	369	9,022	10,452	160	3.1
Pennsylvania (anthracite).....	42	95	1,865,677	16,289,110	\$88,566,614	13,834	8,200	9,334	31,368	273	2.1

Compiled by U. S. Bureau of Mines.  
 \* For mines that recover coal both by stripping and by underground operations, the returns do not permit separating men engaged in stripping from those engaged in other work. For this reason the figures of men employed represent all persons working at these mines, including those underground. The total tons produced by both methods at these same mines also are shown.  
 (a) Includes also shotfirers.  
 (b) California, Iowa, Montana and Texas.



## Foreign Market And Export News

### Welsh Trade Unsettled; Export Market Uncertain; Newcastle Still Sluggish

Though the tonnage situation has improved with better weather, the Welsh steam coal trade is still unsettled as regards early shipments. Coal has accumulated to a considerable extent and operators are still engaged in clearing their cars, until which time regular working of the pits is impossible.

The prospects of improved export of Welsh coal are not altogether good because shipping is still short of requirements and freights are heavy. On the other hand the operators have plenty of orders in hand and the ruling high freights will no doubt attract shipping before long.

The best contract to report is one for 32,000 tons of best Admiralty large for the Palestine Rys. for delivery for six months from April to Haifa. Beyond this there seems to be little inclination on the part of either buyers or sellers to enter into negotiations pending the developments in the industry after May 1. So far the returns show a discrepancy of 3s. 2d. per ton between the cost of production and the selling prices, the discrepancy, of course, being on the wrong side of the balance sheet.

The Newcastle market is dull and cheerless and the prospects for the next month are anything but favorable. Newcastle is still losing business to Germany and Silesia.

Output by British collieries during the week ended March 6, according to a special cable to *Coal Age*, totaled 5,285,000 gross tons, compared with 5,370,000 tons in the preceding week.

### French Market Marks Time

Paris, France, March 4.—Demand for industrial fuels continues satisfactory, but the consumption of domestic grades has been greatly reduced. British imports of household fuel have been sharply reduced.

Belgian sellers of sized coal have decided to apply to the March deliveries in France the same price estimate as for last month. Owing to the rate of exchange this means an increase of 6@10 fr. per ton. Russian anthracitic is a drug on the market in the Paris

district; cobbles can be used only for central heating purposes. In Rouen, Russian nuts, 25/55, are quoted at 380 fr. and cobbles 55/80 at 370 fr. These prices are out of line with Welsh anthracite, quotations of 390@435 and 380@410 fr., respectively, for the same sizes.

During the first twenty days of February, the O.H.S. received 354,900 tons of coal, 187,000 tons of coke and 24,900 tons of lignite briquet from the Ruhr.

The O.H.S. new price list for indemnity coals, effective March 1, increases the price of coal delivered by sea 5 fr. The price of industrial coal delivered via the Belgian frontier is increased 3 fr., on unscreened 20/25 and 5 fr., on unscreened 30/40.

### Belgian Trade Holds Position

There was no material change in the Belgian coal market the first week of the month, reports Brussels under date of March 4. Orders have been reduced for some grades of both steam and domestic coals, but prices generally are well maintained. The exception has been in the quotations on certain domestic coals for which demand has almost disappeared.

French imports are below last year's figures, but the difference between January, 1926, and December, 1925, was only about 5,000 tons. British and Dutch arrivals are more irregular. Receipts of free German coal are near a vanishing point. On Jan. 31 Belgian stocks were down to 1,398,180 metric tons, as compared with 1,558,120 tons a month earlier.

There is a good demand for industrial lean coals. Semi-bituminous steams are not much sought after, but the 5x10, 6x8 and 10x15 grades are strong and prices have been increased 2@4 fr. per ton in both the Borinage and Liege districts. Screened sizes are almost unprocurable and coking smalls are firm. Duffs for brick-making are held at 66 fr.

Current quotations are as follows:

**Anthracitic:** 80x120, 180 fr.; 50x80, 200 fr.; 30x50, 215 fr.; 20x30, 175 fr.  
**Semi-bituminous:** 80x120, 140@145 fr.; 50x80, 150@155 fr.; 30x70, 175 fr.  
**Bituminous:** 80x120, 135@140 fr.; 50x80, 150@155 fr.; 30x70, 155@160 fr.; 20x30, 130@140 fr.

The demand for briquets has im-

proved a little, but it is still unsatisfactory. The prices of patent fuels rise in proportion with the price of pitch.

Belgium received 312,632 tons of reparation fuels (including 11,266 tons of coke) from Germany in January, as against 275,875 tons in December.

### Chile Mines 1,473,000 Tons

Chile's coal production during 1925 has been estimated at 1,473,000 metric tons by the geological section of the Chilean Ministry of Agriculture, Industry and Colonization. Although this figure is 40,000 tons less than that for 1924, it is still considered unexpectedly high, as a number of mines worked only part time a large part of the year.

### Export Clearances, Week Ended March 18, 1926

FROM HAMPTON ROADS	
For Brazil:	Tons
Nor. Str. Augvald, for Rio de Janeiro	6,532
Ital. Str. Calaba, for Rio de Janeiro	7,251
For Bermuda:	
Nor. Str. Gerion, for St. Georges	2,995
For Italy:	
Ital. Str. Marina O, for Porto Ferrajo	1,910
For Cuba:	
Br. Str. European, for Havana	4,607
Dan. Str. Delaware, for Havana	3,717
For Argentina:	
Br. Str. Illingworth, for Buenos Aires	7,232
For Spain:	
Br. Str. Denham, for Valencia	3,355
For Newfoundland:	
Nor. Str. Urter, for St. Johns	2,003
FROM BALTIMORE	
For Argentine:	
Br. Str. Rustington, for Buenos Aires	5,397
For Italy:	
Ital. Str. Valcerusa, for Civitavecchia	7,133
FROM PHILADELPHIA	
For Cuba:	
Nor. Str. Thorgend, for Havana	—

### Hampton Roads Coal Dumpings\*

(In Gross Tons)		
	Mar. 11	Mar. 18
N. & W. Piers, Lamberts Pt.	164,800	190,426
Tons dumped for week		
Virginian Piers, Sewalls Pt.	84,816	127,159
Tons dumped for week		
C. & O. Piers, Newport News	147,706	167,546
Tons dumped for week		

\* Data on cars on hand, tonnage on hand and tonnage waiting withheld due to shippers' protest.

### Pier and Bunker Prices, Gross Tons

	PIERS	
	March 13	March 20†
Pool 1, New York	\$5.65@5.85	\$5.50@5.75
Pool 9, New York	5.20@ 5.40	5.15@ 6.35
Pool 10, New York	4.80@ 5.10	5.75@ 6.10
Pool 11, New York	4.50@ 4.75	4.50@ 4.75
Pool 9, Philadelphia	5.10@ 5.40	5.10@ 5.40
Pool 10, Philadelphia	4.95@ 5.15	4.95@ 5.15
Pool 11, Philadelphia	4.60@ 4.80	4.60@ 4.80
Pool 1, Hamp. Roads	4.50@ 4.55	4.50@ 4.60
Pool 2, Hamp. Roads	4.20@ 4.30	4.25@ 4.30
Pools 5-6-7, Hamp. Rds.	3.90@ 4.00	3.90@ 4.00
BUNKERS		
Pool 1, New York	\$5.90@6.10	\$5.75@6.00
Pool 9, New York	5.45@ 5.65	5.40@ 5.60
Pool 10, New York	5.05@ 5.35	5.00@ 5.35
Pool 11, New York	4.75@ 5.00	4.75@ 5.00
Pool 9, Philadelphia	5.35@ 5.65	5.35@ 5.65
Pool 10, Philadelphia	5.20@ 5.40	5.20@ 5.40
Pool 11, Philadelphia	4.85@ 5.05	4.85@ 5.05
Pool 1, Hamp. Roads	4.55	4.60
Pool 2, Hamp. Roads	4.30	4.30
Pools 5-6-7, Hamp. Rds.	4.00	4.10

### Current Quotations, British Coal, f.o.b.

Port, Gross Tons		
Quotations by Cable to <i>Coal Age</i>		
Cardiff:	March 13	March 20†
Admiralty, large	23s.@24s.	23s.6d.@24s.
Steam smalls	12s.	12s.
Newcastle:		
Best steams	17s.@18s.	18s.
Best gas	19s.	20s.
Best bunkers	16s.6d.	16s.

† Advances over previous week shown in heavy type; declines in italics.

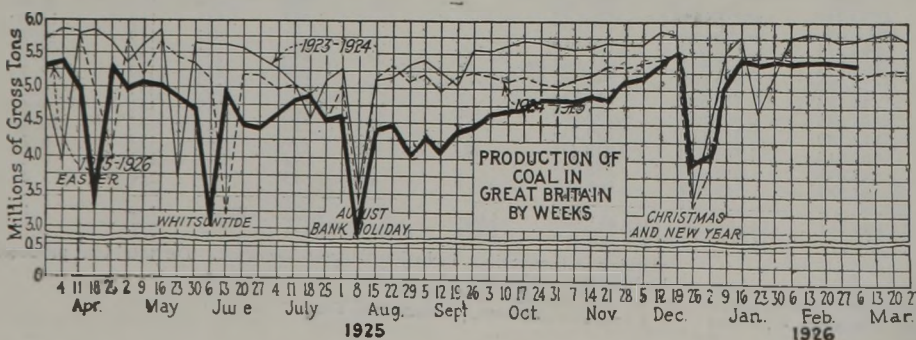



## Coming Meetings

Lehigh Valley Section, A. I. E. E. Sterling Hotel, Wilkes-Barre, Pa., March 26, 6:30 p.m. Secretary Wilkes-Barre section, E. B. Wagner.

New England Coal Dealers' Association. Annual meeting, State Armory, Worcester, Mass., April 7 and 8. Secretary, E. I. Clark, 141 Milk St., Boston, Mass.

American Welding Society. Annual convention, 29 West 39th St., New York City, April 21-23. Secretary, M. M. Kelly, 29 West 39th St., New York City.

California Retail Fuel Dealers Association. Thirteenth annual convention at Del Monte, Calif., April 22-24. Secretary, J. B. Muir, Oakland, Calif.

National Retail Coal Merchants' Association. Ninth annual convention, New Willard Hotel, Washington, D. C., May 17-19. Resident vice-president, Joseph E. O'Toole, Transportation Bldg., Washington, D. C.

Electric Power Club. Convention at The Homestead, Hot Springs, Va., May 24-27. Secretary, S. N. Clarkson, B. F. Keith Bldg., Cleveland, Ohio.

The American Mining Congress. Annual Exposition of Coal Mining Equipment, May 24-28, at Cincinnati, Ohio, in conjunction with the annual meeting of practical operating officials. Assistant secretary, E. R. Coombes, Washington, D. C.

International Geological Congress. The fourteenth congress will be held in Madrid, Spain, commencing May 24, 1926. From May 5 to 22 excursions of interest to the visiting delegates will be arranged. Information concerning the congress can be obtained from the secretary of the organizing committee, Enrique Dupuy de Lome, Plaza de los Mostenses, 2, Madrid, Spain.

Midwest Retail Coal Merchants Association. Annual meeting, May 25 and 26, at Kansas City, Mo. Secretary, James P. Andriano, St. Joseph, Mo.

Western Canada Fuel Association. Annual meeting at Winnipeg, Manitoba, Can., May 27 and 28. Secretary, W. H. Morrison, Winnipeg.

American Wholesale Coal Association. Annual meeting at Toledo, Ohio, June 7-9. Treasurer, R. B. Starek, Union Fuel Bldg., Chicago, Ill.

Association of Iron & Steel Electrical Engineers. Exposition and convention at Hotel Sherman, Chicago, Ill., June 7-10. Secretary, J. F. Kelly, 1007 Empire Bldg., Pittsburgh, Pa.

American Institute of Electrical Engineers. Annual convention, White Sulphur Springs, W. Va., June 21-25. Secretary, F. L. Hutchinson, 29 West 39th St., New York City.

American Society for Testing Materials. Convention at Haddon Hall, Atlantic City, N. J., June 21-25. Secretary, C. L. Warwick, 1315 Spruce St., Philadelphia, Pa.

American Society of Mechanical Engineers. Spring convention at San Francisco, Calif., June 28-30. Secretary, Calvin W. Rice, 29 West 39th St., New York City.

## New Equipment

### Insulated Connector Affords High Current Capacity

Small diameter, high current capacity, a lack of screws or bolts, the ability to hold against considerable tension before pulling apart, and provision for quick connection and disconnection are highly valuable attributes of any motor lead connector. The new cable connector of the Ohio Brass Co., Mansfield, Ohio, embodies these features.

This connector is intended for use on motor leads and trolley-pole connections of mine locomotives as well as for general use on stationary and portable motors. The terminals, which are of phosphor-bronze, have a double-spring contact. The slotted end of the male connection is compressed by the solid part of the female portion, and likewise the slotted end of the female element grips the solid portion of the male. One excellent detail of the design is the raised ring or boss on the solid portion of the male element. This fits into a corresponding groove in the spring or slotted part of the female element and gives the connector its ability to withstand considerable pull before coming apart.

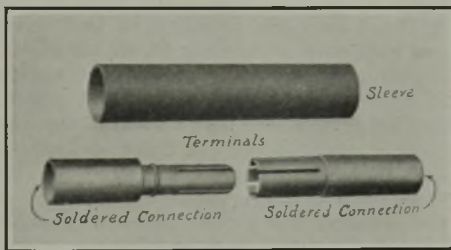

#### Easily Made but Tenacious

The two terminals are soldered to the cables to be connected. A push forces the two parts together and the ring on the one fitting into an internal groove on the other holds them in place. A rubber sleeve spans the completed connection and insulates it.

The cable ends are soldered into the tinned sockets of the connector. In application the cable insulation is trimmed back just far enough so that when the connector is snapped together the distance between the ends of the insulation is slightly less than the length of the tight-fitting rubber sleeve which spans and covers the metal sleeves. In this way a well-insulated joint is attained without the use of tape.

### Trolley Guard-Board Support

A simple clamp that makes it possible to install guard boards after a trolley line is in place in a mine is a recent development of the Ohio Brass Co., of Mansfield, Ohio.

Often when haulage ways are extended it becomes desirable to add guard boards to the trolley line. This simple device consisting of two clamping pieces and bolts, can be fastened around the skirt of any insulated trolley hanger having a diameter ranging from

3¼ to 3½ in. After the two clamping pieces are rigidly attached to the hanger, it is a simple matter to slip suitably drilled guard boards over the extended clamping bolts. A nut and washer on the outside of each guard board holds it in place.

This fitting is said not to affect the installed trolley hanger or clamp and can be readily removed and reinstalled in another location when desired.

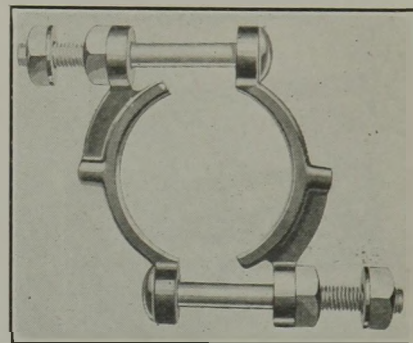

#### Fastens Board to Insulated Trolley Hangers

This clamp may be slipped around the skirt of hanger. The clamping bolts are then passed through holes in the guard boards. Both trolley and guards are thus suspended from the same hangers.

### A New Recording Pyrometer

Charles Engelhard, Inc., 30 Church St., New York City, has recently brought out the Type S recording pyrometer illustrated in Figs. 1 and 2, in which have been embodied a number of improvements, principal among these being the mercury contact switch shown in Fig. 3.

The outer case of the instrument is made up of two castings, the back half, which forms the base of the instrument, being made from cast iron and the front half or cover, from cast aluminum. The mechanism is assembled on a sub-base that is secured to the casing by four bolts.

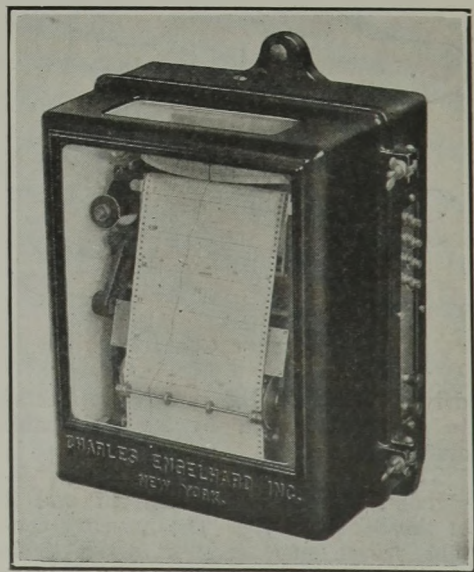

Fig. 1—Type S Recording Pyrometer



The galvanometer-moving system which is mounted on the back of the sub-base responds to the electromotive force applied to the terminals of the instrument, and its deflection from the low-scale division is a measure of the electromotive force, which in most cases is calibrated directly in terms of temperature. A clock mechanism drives

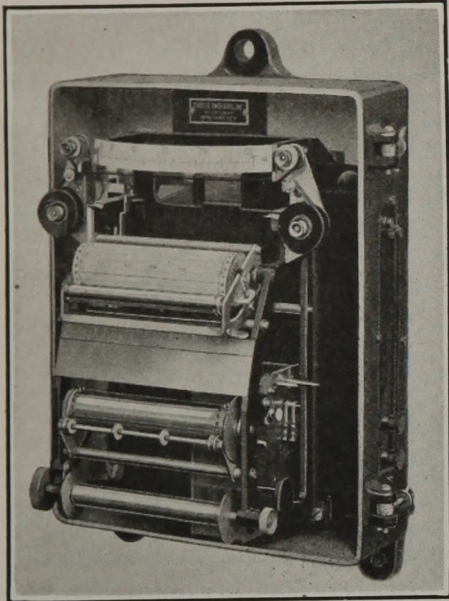

Fig. 2—View of Pyrometer Mechanism

the chart at a fixed rate of speed. A depressor bar above the pointer is operated intermittently from the power unit. When the depressor bar is lowered, the pointer presses the inked ribbon against the chart and records the pointer's position.

The power unit is controlled from a contact switch mounted on the clock. Each time that a circuit is established through this contact switch, the power solenoid is drawn down and drops the depressor bar against the pointer.

The recording chart is of the ribbon type and approximately 100 ft. in length, the over-all width of the chart being 6 3/8 in. This chart is held against the driving drum by a series of rollers that are mounted in a separate frame, hinged so it can be swung outward while the rolls are being changed. The

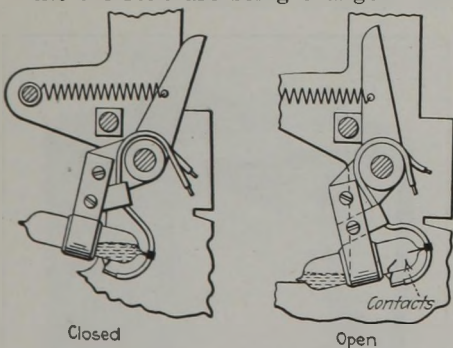

Fig. 3—Mercury Contact Switch

driving drum for the chart is connected to the gear train by an adjustable clutch.

The electric clock for the unit is designed for alternating current and is of the Warren type. The mercury contact switch previously referred to is furnished on the multi-record instrument and forms part of the power unit. This switch consists of levers mounted

on a spindle and spaced from one another. To the lower ends of the levers is attached a small glass tube containing mercury and sealed-in electrodes. The normal position of the levers is such that the bulbs are tilted and the mercury is not in contact with the electrodes. Opposite each lever on a revolving spindle that is connected to the pinion of the power unit is a stud that throws the lever forward when turned to the right position. This action tilts the switch bulb so that the mercury completes the circuit between the two electrodes as shown in the closed position, in Fig. 3.

### Automatic Re-centering Motor Bearings

Many of the troubles experienced with electric motors are the result of bearing wear permitting the rotor to rub on the stator. To insure a continuous uniform air gap in motors, the Howell Electric Motors Co., of Howell, Mich., has brought out a complete line of motors with anti-friction bearings, in which any looseness in the bearing, caused by wear or otherwise, is instantly and automatically taken up, so as to keep the rotor of the motor continually centered. This is done by using a Timken tapered roller bearing, shimmed with a fluted wire spring which acts as a compression spring.

The inner race or cone of the roller bearing is fitted on the shaft with a light press fit. The outer race or cup is fitted into the housing of the motor end bell with a sucking fit which allows creeping of the outer race. The spring is held tight against this outer cup by the outer grease cap; pushing the cup tightly against the rollers and keeping the bearings tight at all times. This type of bearing is put in each end of the motor. The roller bearing is made of nickel-molybdenum steel.

### Two-Piece Locomotive Tire

In the accompanying illustration may be seen a new type of locomotive tire recently patented by J. N. Abbott, superintendent of Mine No. 3 of the Columbus Mining Co., of Christopher, Ky. In this construction the tire is made in two parts, the inner one carrying the flange and the outer acting as the tread proper.

When the tread wears, as all treads do, it can be replaced without incurring the expense incident to a complete tire renewal. In order to change locomotive tires at most mines it is necessary to withdraw the drivers and their connecting axle, remove the gear and send the balance to the machine shop where the tires are ground or turned down. This consumes much time and keeps the locomotive out of commission for at least one shift.

With the construction here shown it is claimed that a change can be made much more quickly. It is merely necessary to raise one end of the locomotive and cut off the worn tread either with a hammer and chisel or with the acetylene torch. The new tread having been previously heated may then be slipped into place, and allowed to shrink. It is claimed that replacement

of a worn tread may be accomplished in a few minutes time and that one flange will outlast several treads.

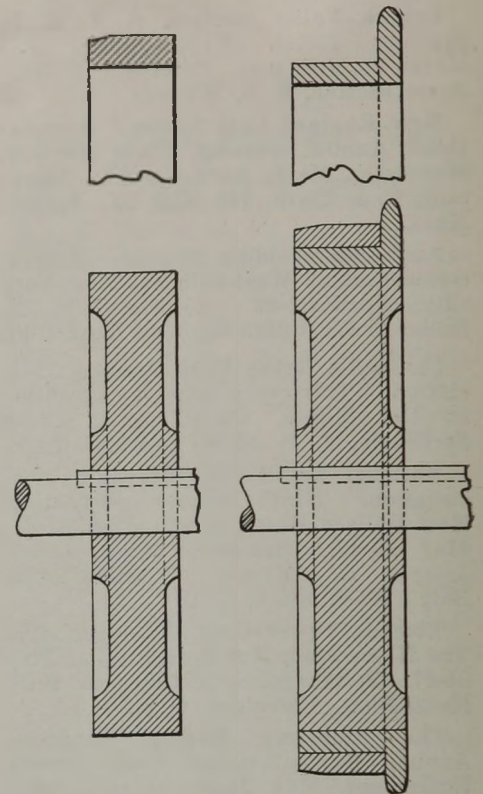

Cross-Sections of Wheel and Tire

As may be seen the tire is made in two parts the flange being part of the inner band and the outer one serving as the tread proper. Inasmuch as the tread wears much more rapidly than does the flange it is well that the former can be removed without making a renewal of the flange necessary.

### Clamp Holds Angle Iron Trolley

The use of the bulldog trolley clamp principle has been extended by a recent development of the Ohio Brass Co. to include an application where angle iron is employed as the trolley contact. The adaptation consists in the substitution of clamping jaws shaped to grip a standard 2 1/2 x 2 1/2-in. angle, in place of the customary wire clamping jaws. With this device the bulldog line is said to include suitable clamps to handle practically any form of trolley contact and feeder suspension.

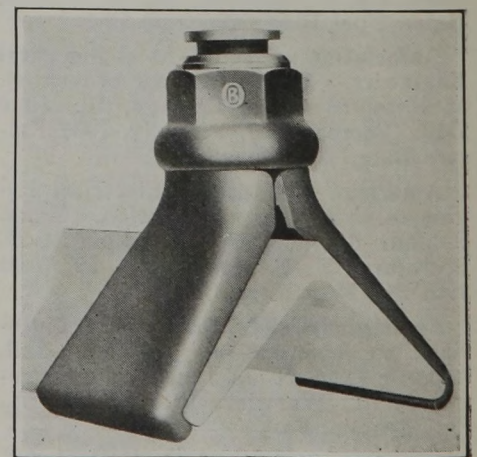

Angle Iron Clamp with Strong Holding Jaws

Trolley lines made of angle iron can now be supported by a type of clamp commonly used for mine trolley suspension.