

COAL AGE

Established 1911—McGraw-Hill Publishing Company, Inc.



DEVOTED TO THE OPERATING, TECHNICAL AND BUSINESS PROBLEMS OF THE COAL-MINING INDUSTRY

SYDNEY A. HALE, Editor

New York, July, 1936



A Little Helps

BECAUSE a siphon is not needed where a pump is provided, there is no reason why the siphon principle should not be used wherever the velocity of discharge does not exceed the velocity with which water would fall from the end of a siphoned pipe. Thus some of the lift might be saved. It would seem well to bend the discharge pipe gently over and lead it down a side hill wherever such a side hill is available and thus cut down the load on the pump, or even in cases bypass it altogether. If the discharge is made in the mine, sometimes by a mere extension of the line a greater flow might be induced.

Sheathed Explosives

NONE of the explosives manufactured in America is intended for firing in a free explosive mixture of methane and air, but that is a condition often closely approached when a large open crevice leads from the air into the borehole in which the shot is fired. The air in the working place may not contain any large quantity of gas, but the crevice, being fed with methane from the coal seam, may contain a highly explosive mixture.

These conditions have made the Belgians and many British favor an explosive covered by a one-eighth-inch sheath, or less, of sodium bicarbonate or other inert dust that will cool the flame of the combustion. With longwall, long breaks often occur in the face ahead of mining, and against the occurrence of these sheathed explosives furnish a defence. With room-and-pillar workings, such as are general here, the danger is not so great, for breaks induced by mining ahead of the pillar are unlikely and

crevices in pillars, which are frequent, are less often filled with sufficient firedamp. However, in places methane may be present in volume enough to create a dangerous condition, especially where the places advance with great rapidity and the pillars are promptly and rapidly drawn.

Another dangerously creviced condition arises from the operation of several superincumbent beds either together or at intervals of time, especially when the lower beds are removed first. That also is not as common here as in Europe. However, such cases in places arise, and in the future may occur more frequently than heretofore. As and when they do, sheathed explosives can be manufactured. Meantime, it would be well to note if in boreholes the crevices often found in European seams may be occurring in those of this country. Regarding such dangers little has hitherto been published in the United States, though multiple-seam mining, high concentration of workings and longwall may change conditions.

Lucky Accident

EAGERNESS of the 74th Congress to call it a day brought an inglorious end to the Guffey-Vinson bill in the Senate on June 20. Passed by the House by a vote of 161 to 90 four days earlier, Senatorial administration spokesmen were unwilling to try conclusions with filibustering opponents and permitted final adjournment without forcing the measure to a vote. Thus the *status quo* created by the decision of the Supreme Court invalidating the vital sections of the predecessor Guffey-Snyder act is preserved until a new Congress assembles next January.

This defeat of the proposals hurriedly put forth by proponents of regulation after the

Supreme Court decision on May 18 is fortunate. These proposals cured none of the major defects of the 1935 statute and their enactment promised nothing but another series of disturbing legal battles. Although conditions in bituminous mining impress many coal interests with the desirability of legislative assistance in solving the manifold problems confronting the industry, the opposition to the Guffey-Vinson bill is persuasive that that particular measure falls far short of the mark.

The breathing spell given by the adjournment of Congress, therefore, can be well employed by both camps in trying to work out proposals which will win wider acceptance and which will meet some of the valid criticisms leveled against the Guffey-Vinson bill in its present form. In the meantime, those groups that insist that self-regulation is possible without federal intervention and supervision face the task of endeavoring to translate their claims into actualities. Friends and foes alike should support them in this endeavor for the ultimate good of the whole industry.

Roof or Floor?

IN DRIVING blind rock tunnels a long pipe provides ventilation with the air either driven under pressure or exhausted. If an exhaust pipe is provided, the dust and gases from blasting are drawn away from the working face into the pipe to be discharged eventually into the return. Thus handled, the polluted air can harm only the fan. If the air is driven into the face under pressure, however, the dust returns in the open tunnel, where it may enter the lungs of the workers and cause silicosis and where any nitrous gases from the explosive reaction may render workmen more subject to that disease. As the flow of air in the tunnel beyond the end of the pipe is horizontal, dust, unless heavy and coarse, has no disposition to settle to the floor.

The pipe also may be placed near the floor or near the roof. If the floor pipe exhausts air, it will aid gravity in bringing down both dust and gases, whereas if the exhaust pipe is near the roof, it will oppose the action of gravity. Logically, the exhaust roof pipe should be used only where methane or some light gas is to be removed and not gases from an explosion. As a floor pipe can be faced with a front

that shooting will not damage, its end can be placed much nearer the working face than a roof pipe, and there its operation will be more effective than if it is placed with its end about 100 ft. back, though perhaps its orifice should be masked by a barrier that will prevent pieces of rock from being directly projected into its interior, eventually blocking it. An exhaust floor pipe would remove any drilling dust that might fail to be caught by other means. Fine dust falls slowly but will inevitably fall more readily if it is drawn down than if it has to oppose an upward air current.

Forestalling Breakdowns

AN INDICATION of the value of periodic insulation-resistance tests on substation equipment is afforded by a study of recent experiences of a bituminous company which makes the tests four times per year. In one instance, two successive quarterly readings on a 200-kw. converter armature were 1 megohm and 300,000 ohms respectively. The inspection report called attention to the drop in resistance and advocated that the machine winding be blown out or otherwise cleaned. Within ten days after the low reading was made—and before the cleaning had been done—the armature failed. In another case, the series and compensating winding of a motor generator showed successive readings of 12 megohms and 40,000 ohms. Within fifteen days after the last reading—and before the machine had been cleaned—the insulation failed.

In the third instance, the armature of a 200-kw. motor generator which had shown 15 megohms dropped to 100,000 ohms. It was blown out at once with compressed air and a second test showed 200,000 ohms. Another blowing raised the resistance to 1 megohm, and after several more blowings the resistance reading increased to 2 megohms. Very likely if the cleaning had been delayed, a failure would have resulted, as in the first two cases. Instead the armature was restored to a safe condition.

Just what is a safe reading, of course, is open to debate. Although a new converter or motor generator should have a resistance of 200 megohms or more, a reading of 1 megohm should not necessarily condemn an old machine for further service.

EFFICIENT TRANSPORTATION

+ Reflects Coordination, Equipment and Materials At New Monarch Mine

By C. C. CONWAY

Chief Electrician, Consolidated Coal Co.
Herrin, Ill.

EARLY in 1931, after several years' experience with mechanical loading at other properties, the Consolidated Coal Co. converted the New Monarch mine from hand loading to mechanical loading. During the period of conversion a modern cleaning plant was installed, haulage equipment was added, the capacity of the hoist was increased by the installation of larger engines, power-distribution systems were changed and loading equipment was installed.

New Monarch mine is in Williamson County, in the extreme southern portion of the Illinois coal field. The coal has a very good analysis and is marketed with a group of coals from the same field, known as the "Quality Circle." Conditions are similar to those usually found in the No. 6 seam in southern Illinois. This seam varies in thickness from 6 to 10 ft., with an average of $7\frac{1}{2}$ ft., and usually is identified by a parting of bluish slate, known as the "blueband," about 18 in. from the bottom and varying in thickness from a barely discernible line to 3 or 4 in. The seam is overlain with a bed of shale varying in thickness and slips are prevalent. This shale is tender and weathers badly, so that it is necessary to leave top coal for roof protection. The bottom is fireclay with an average thickness of about 18 in. Depth of cover at the mine averages 180 ft. and the seam has a general dip of over 1 per cent to the northeast. Thickness of the coal is fairly uniform but the bottom is rolling, so that short grades up to 8 per cent frequently are encountered in haulage.

Average daily output at the New Monarch mine is 4,100 tons with 90 per cent of the total mechanically loaded. Eleven Joy loading machines are used with one loading machine on development work and the remaining ten divided into pairs to form five territories or units. Each unit, consist-

ing of two loading machines, two shortwall cutting machines, three storage-battery locomotives, two service and one relay, and the necessary power-supplying equipment, operates as a separate part of the mine. Each unit is in charge of an assistant mine manager who supervises production to the parting and, above all, looks to the safety of his men.

The room-and-pillar system of mining is used with stub entries turned off the main entries at an angle of 60 deg. to make the haulage curves as gradual as possible. The sketch of a representative section shown in Fig. 1 will also show that the rooms are turned from the entries at an angle of 60 deg. Rooms are 24 ft. wide and are driven

on 60-ft. centers measured along the entry (the actual distance between room centers will be observed to be somewhat less), while the entries are 14 ft. wide on 40-ft. centers, again measured along the entry. In some instances a three-entry system is used to make more working places during development and for later utilization for haulage and ventilation. No pillars are drawn.

Three types of haulage equipment are used at this time, each type being especially selected for the service it is called upon to perform. Haulage begins at the face, where the problem is to remove loaded cars from under the loading machine and substitute empties with as little intervening time as pos-

Fig. 1—Typical working plan at the New Monarch mine

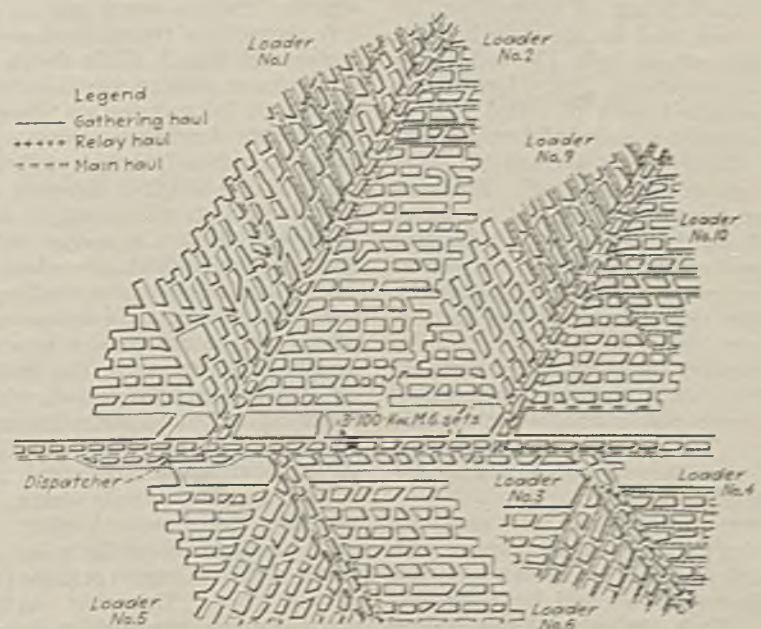

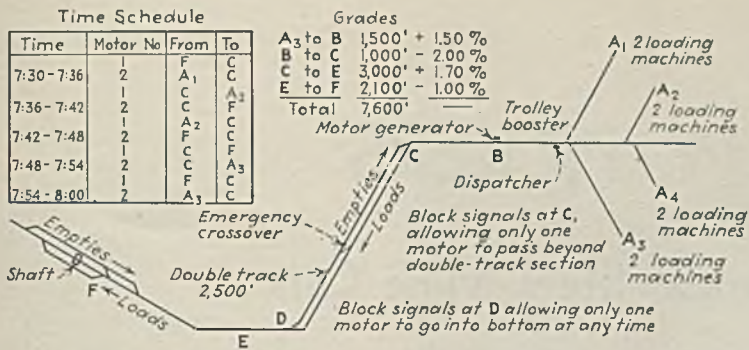

Fig. 2—Typical haulage layout at New Monarch. Two 15-ton main-line locomotives haul 32 trips of 30 cars each, or a total of 960 cars, loaded by eight loading machines

loose wheels safely past the point. The manganese steel has shown a very high resistance to abrasion and sufficient toughness so that there has been no breakage.

In connection with track the method of bonding customarily is mentioned. Very little bonding is done, however, as the inside or secondary haulage tracks are not used for power return and the main haulage roads are welded in preference to bonding. Gathering haulage track is located beyond the travel of the main haulage motors and, as the gathering locomotives are all powered by storage batteries, it is not necessary to have a rail return. Return conductors are necessary, of course, for the loading, cutting and drilling machines, but it has been found convenient and economical to duplicate the power feeders and use the duplicate wire for return purposes.

The welding of rail joints instead of the usual bonding was first experimented with in July, 1933. It was known that the rails could be welded, but there was some question as to whether they could be economically welded and still withstand the vibration and pounding without breaking. The electrical resistance, as compared to bonding, also was unknown, but it was believed that it would be much lower.

Track Welding Gets Severe Test

The first track welding was attempted on a 6,000-ft. section of 40-lb. track. This section was considered difficult, as 1,300 loads were pulled over it every working day, and in addition difficulty was being experienced with the roadbed, which was wet even though sumps were located every few hundred feet and were pumped regularly. Conditions were right for a severe test, as the traffic was heavy and the roadbed allowed a maximum amount of working at the joints.

The bonds on the 6,000-ft. test section were carefully tested. All of the bonding was allowed to remain on the rails, but all joints testing a resistance greater than the equivalent of 6 ft. of rail were marked for welding. To

weld the joints they were first cut with an oxyacetylene torch to form a "vee" at the joint opening. That is, the ends of both rails were cut on an angle so that a vee was formed at the joint and in the ball of the rail. The rails were then welded together and the vee was filled with a general-purpose rod. The weld was then surfaced with manganese. All welding and surfacing were done by arc welding. Results were very satisfying, for the resistance of the welded joints was equivalent to about 1 ft. of rail as compared to 4½ ft. (40-lb. rail) for a 4/0 bond. Inspection after 2½ years of service showed very few failures of welds made in the original attempt.

Stronger Joint Obtained

The method of welding has been improved, however, so that a stronger joint with a lower resistance results. A sketch of a welded joint is shown in Fig. 3. The upper section of each rail still is cut to form a "vee" at the joint opening. In this connection it should be mentioned that the cut should be no more than is necessary to enable the welding operator to weld the full ball of the rail. After the joint has been prepared by oxyacetylene cutting, the entire section of the rails above the web are welded together. The vee is filled during this process, but sufficient room is allowed for a surface of well-peened manganese. It will be noted from the sketch that the splice bars now are welded solidly to the rails throughout their entire length (24 in. in 60-lb. construction) and also at the ends. Both splice bars are welded and the result is an exceptionally strong joint, eliminating trouble due to splice bars loosening and allowing the joints to work.

Tests of rails welded as shown in Fig. 3 indicate that the resistance of a section of rail including a welded joint is almost exactly that of an equivalent length of the same size rail. In other words, no appreciable resistance is added by joints when they are properly welded.

Three questions usually are asked about the welding of joints. They

are: (1) What provisions are made to take care of expansion and contraction? (2) How can the rails be reclaimed? (3) How does the cost compare with bonding?

Our experience has been that no provisions are necessary to provide for expansion and contraction, as the temperature variation does not exceed 1 deg. over the entire year. Although no movement has been observed, it is possible that a slight amount takes place, in which case it would be absorbed at the switches, which are not welded but are bonded with electrically welded copper bonds.

Reclaiming of welded rails proved to be a simpler task than had been supposed. The procedure is to remove the bolts and then drive wedges under the splice bars. The wedges are driven from the end, along the web of the rail, in the arch left open by the fit of the splice bar. After the splice bars have been removed, the weld at the ball of the rail can be broken by working the loose end of the rail. An advantage

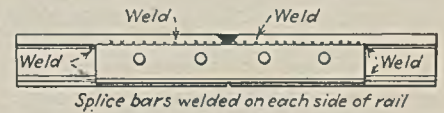

Fig. 3—Elevation of 60-lb. rail joint showing method of welding

of 25 or 30 ft. (depending upon the length of the rail) of leverage is gained by applying force at the loose end of the rail.

The cost of welding joints is considerably less than bonding, as shown by the following itemized costs (power costs have been omitted in both cases). Labor and material required for 152 welded joints is as follows:

Oxygen	\$8.12
Acetylene	6.30
186 lb. ¼-in. welding rod @ \$0.06 ...	11.16
14 lb. manganese rod @ \$0.76	10.64
86 hr. labor @ \$0.78½	67.51
Total cost for 152 welds.....	\$103.73
Cost per welded joint	\$0.682

The labor and material required for 40 bonds applied with the electric arc is as follows:

40 28-in. 4/0 bonds @ \$0.63.....	\$25.20
12 lb. copper rod @ \$0.33	3.96
14 hr. labor @ \$0.78½	11.00
Total cost for 40 bonds	\$40.16
Cost per bonded joint	\$1.004

The advantages of welding rails in preference to bonding are: 30 per cent lower cost, stronger track joints, lower maintenance and lower resistance. The disadvantages are: some difficulty in reclaiming and a heavier investment in equipment. The equipment necessary for the welding of rail joints consists of oxyacetylene cutting equipment and a motor-generator welder. The welding machine should have a capacity of 300 amp.

RETRACTILE-TYPE PICKERS

+ And Use of High-Tensile-Steel Mine Cars

Feature New Red Jacket, Jr., Development

By J. H. EDWARDS

Associate Editor, Coal Age

TOTAL mine capacity of Wyoming County, West Virginia, was increased approximately 30 per cent this year when the Red Jacket Jr. Coal Co. opened its low-volatile mine at Wyoming, a new post office, located in virgin mining territory 14 miles north-northwest of Welch. The modern plant and preparation equipment, rated 350 tons per hour, incorporates several outstanding features, one of which, a retractile-type design for picking tables, looms as a new application in tippie construction. Mine cars purchased for the plant have exceptional capacity for their diminutive height and are constructed of high-tensile steel which reduced the weight by 575 lb.

Completion of the Guyandotte River Line of the Virginian Ry. from Elmore to Gilbert, 35 miles, during 1935, provided the outlet for this territory, where the W. M. Ritter Lumber Co., parent concern to the Red Jacket Jr. Coal Co. and to an affiliate, the Red Jacket Consolidated Coal & Coke Co., owns 74,000 acres of fee and mineral. The Wyoming plant investment includes a railroad

bridge over the Guyandotte River and a mile of spur track connecting the tippie with the new line.

The new mine was opened to add a high-grade low-volatile coal to the group being produced by the Red Jacket companies and to develop the large virgin area owned by the parent company. Approximately 3,600 acres constitutes the area allotted to the new plant. The seam is 38 to 42 in. thick, is free of regular impurities, lies above water level in mountainous terrain, and yields a coal of approximately 15,250 B.t.u., 22 per cent volatile, 0.45 per cent sulphur and 2½ per cent ash which has a fusion softening temperature of 2,760 deg. F. Hard bottom underlies the bed and the top is good except for 1 to 2 in. of fairly hard slate which comes down in some places.

Shipments can be made over new connections with the Chesapeake & Ohio and Norfolk & Western railways as well as over the Virginian. From Gilbert the Chesapeake & Ohio effected a connection by building a quarter mile of line and the Norfolk & Western by

building 12 miles from Wharncliffe to Gilbert. Tug River and Pocahontas, Group 3, freight rates apply and Pocahontas district wage scales govern.

From start to finish the Wyoming plant development has been an engineering job and this is evidenced by the simplicity of the general layout, straight evenly graded tracks and sturdy construction of all permanent features. The plant is complete with a commodious commissary and office building and inviting dwellings for miners and local officials.

The five-track tippie and auxiliary equipment were designed and furnished by the Morrow Manufacturing Co. and the steel work was furnished and erected by the Virginia Bridge & Iron Co. A rotary dump, an inspection table in the headhouse, a Norton pick breaker, a crusher for soft coal and special arrangements for handling, mixing and reassembling indicate that money was not spared in obtaining equipment best suited to the job of ef-

Mine-yard trolley wires are supported by posts of 40-lb. rail and crossbars of 30-lb. rail

Although this mine car stands but 20 in. above the rail, it has a level-full capacity of 104 cu.ft.

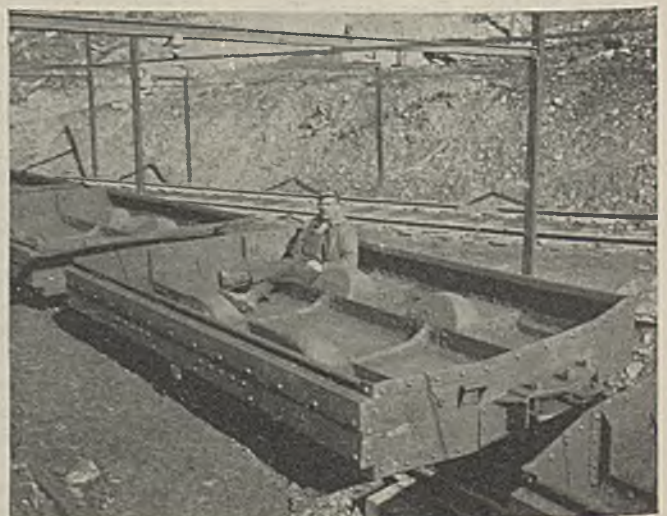

ficiently sizing with minimum degradation, and equipment designed for long life at low maintenance cost.

Unique are the four retractile-type picking tables which with their respective rescreens are built as units that have main frames mounted on wheels. The rescreens are situated at the front (next to the loading boom) of the retractile units. Moving a whole unit back a few feet into space provided under the primary and secondary shaking screens brings the front end back so that it discharges into a mixing conveyor instead of onto the respective loading boom.

The conveyor of the retractile unit which handles the lump is reversible so that when the unit is in the extreme retracted position the lump is conveyed in the opposite direction to a breaker. Duplicate picking facilities are provided on this opposite side. The rescreens of the lump, egg and nut retractile units are reciprocating type, but that of the pea unit is a vibrator. Conveyors of all four units are the apron type with short-pitch, plain, unbeaded flights.

Moving the retractile units to effect a change in preparation or mixture is accomplished in a few minutes by two or three men using ratchet wrenches.



Even these steps of heavy treated timber reflect the engineering and thoroughness characteristic of the whole job

Flexible cords hanging from above supply the power to the two motors of each unit. The lump-discharge end of the main shaker screen is fitted with a bifurcated nose which can be changed to effect equally even distribution when

the picking table is reversed to carry lump to the left, which is to the breaker.

Every step from the dumping at the headhouse to the final loading into the railroad cars is effected with the utmost consideration toward elimination of breakage and toward perfection of preparation. Solid-body steel cars of 3½ tons capacity, while hitched en train, are handled through a single-car rotary dump by a car haul consisting of two separate double-tilting spur chains approximately 7½ ft. apart and equidistant from the center line of the track and engaging simultaneously the attachments on either side of the car.

The dump makes a complete revolution and the coal is laid gently onto a curved dumping shield over which it slides to the coal pocket. In the bottom of the dumping shield is a 4x12-ft. power-operated flygate which makes it possible to bypass the coal from any one mine car to an inspection table located on the upper floor of the main-belt feeder house. From this apron-type inspection table the coal slides directly onto the belt. A reciprocating plate feeder on the floor below handles the regular flow of coal to the belt.

This main conveyor belt is 42 in. wide, the length is 230 ft. between cen-

Left: general flowsheet of the Red Jacket Jr. plant; right: details of flow to retractile picking tables and Norton pick breaker

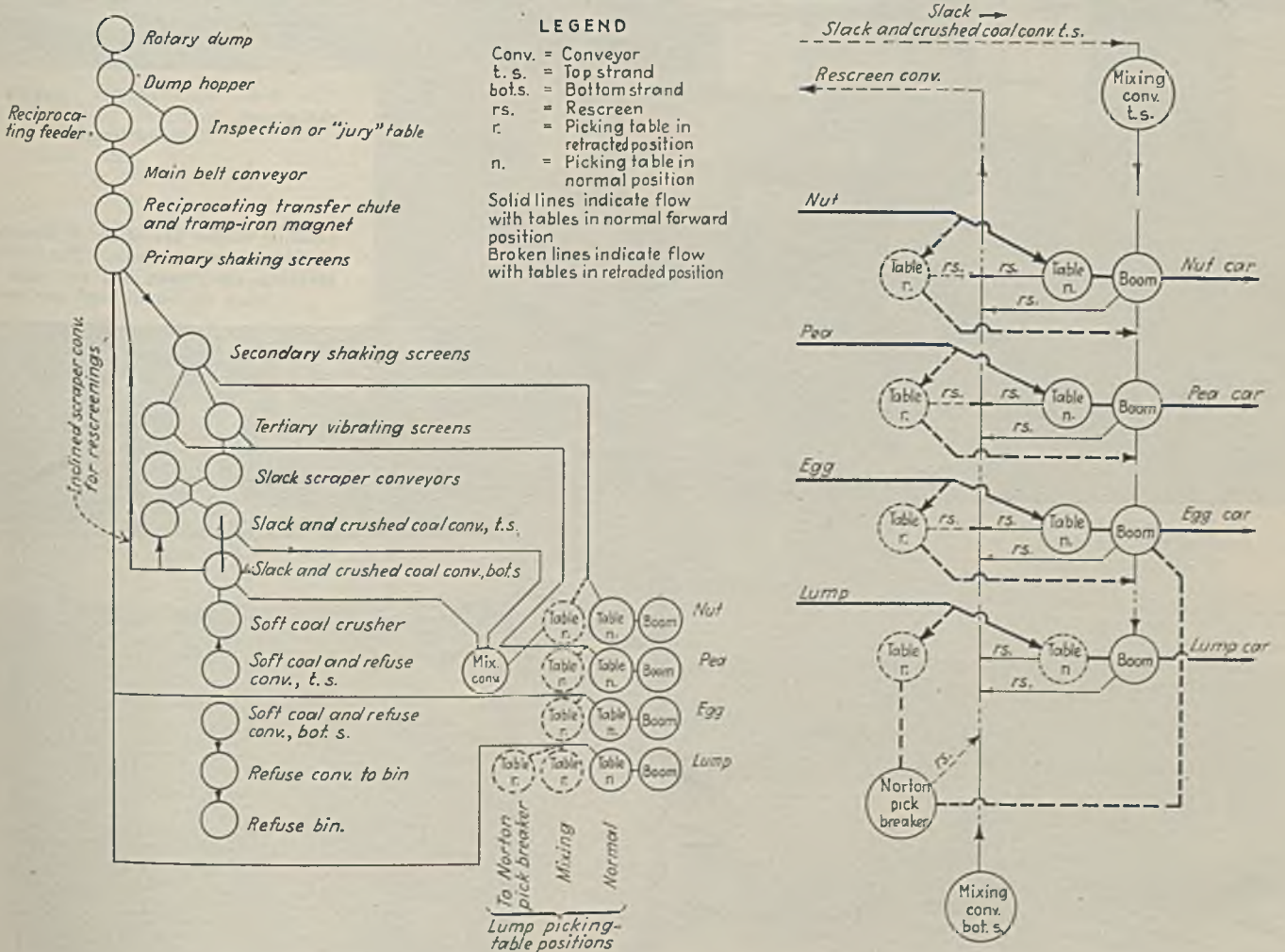

Coal from a selected mine car can be diverted over this inspection, or "jury," table in the feeder room of the headhouse

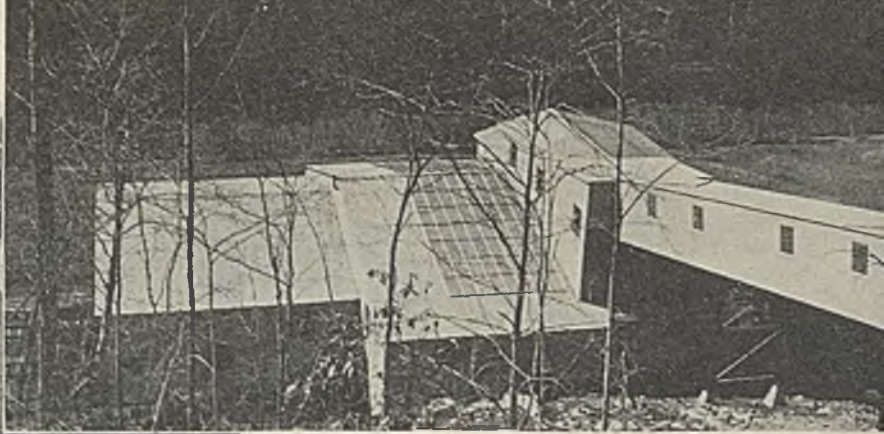
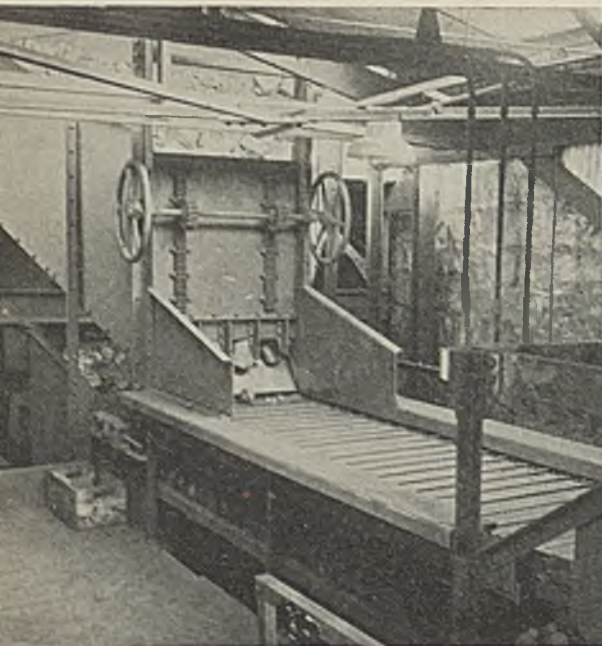

Skylight area over picking-table floor is 1,646 sq. ft.

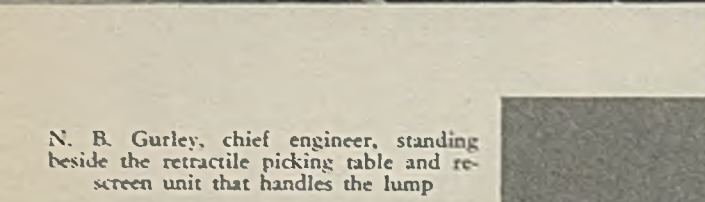

N. B. Gurley, chief engineer, standing beside the retractile picking table and re-screen unit that handles the lump



The four retractile-type picking designated, from near to far: nut, p and lump

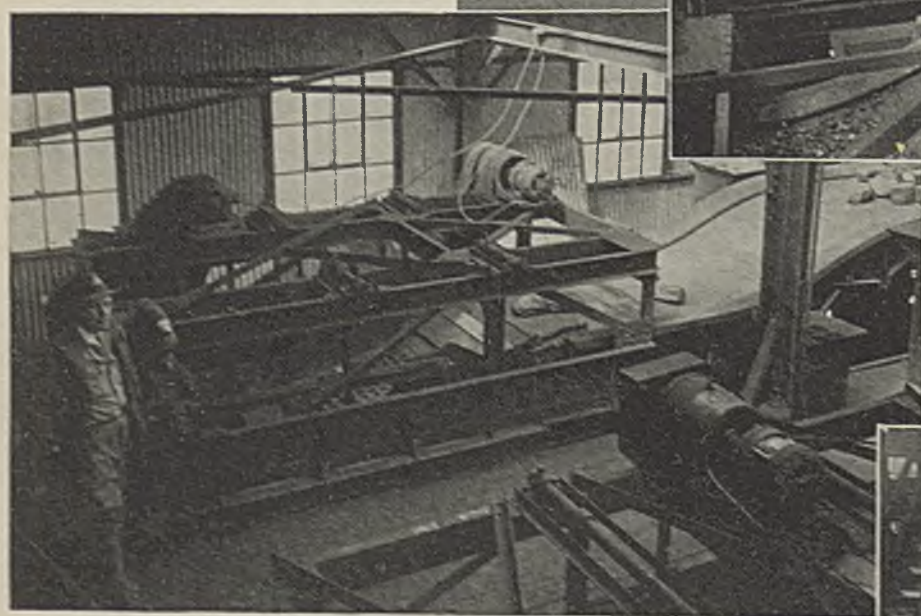

Loading booms are of the flight-scraper equipped with rescreens. The hot-vapor spraying equipment had not been made when the photograph was made

Cars are handled en train through a rotary dump

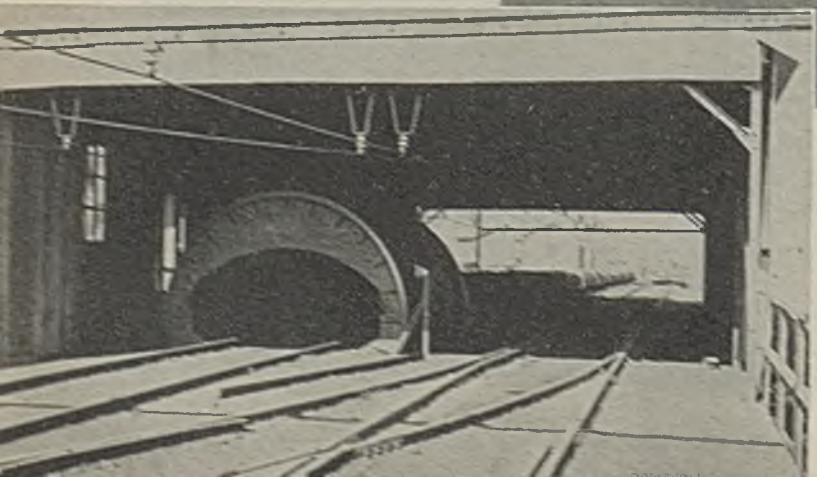



The foreman drops in to inspect the cutting, which is done with a low-vein machine

ters and the pitch is 14 deg. in favor of the load. The belt discharges at the tippie into a box chute where contact is coal to coal instead of coal against steel. Two reciprocating transfer chutes, the lower equipped with a tramp-iron removal magnet, spread the ribbon of coal over the 7-ft. width of the primary shaker screen, which operates at 90 strokes per minute and sizes the lump and egg and discharges the residue to the secondary screens.

These are located below the primary screens, are oppositely inclined and operate at 150 strokes per minute. They size only the nut coal. The residue is separated into pea and slack by two 5x8½-ft. Robins Gyrex tertiary screens. The four loading booms which receive the coal from the retractile picking table and rescreen units are of the flight-scraper type, equipped with rescreens. The breaker is a 48-in. Norton pick type with self-contained sizing screen. The egg coal thus made is mixed with the egg from the primary screens and the residue from the breaker joins the product carried by the rescreen conveyor to be recirculated to the main screens by the rescreen elevator.

The bottom strand of the mixing conveyor, which is situated under the points where the retractile units discharge onto the loading booms, delivers rescreenings to an inclined rescreen conveyor. A Jeffrey 18x18-in. single-roll crusher serves to reduce to fines the soft coal which is picked from the tables. Loading points of all five grades are fitted with facilities for applying dustless treatment consisting of oil sprayed by the Viking hot-vapor process. The equipment consists of a Viking PN-600 pump unit; an SP-200 circulating pump; General Electric LH-400 heating unit, 40-kw., with

thermostatic control; Neptune hot-oil meters; and Viking vapor-spray nozzles. Loading of slack without interruption in changing railroad cars is provided for by a bifurcated chute with flygate. Layer loading of lump and egg sizes is effected by handling the railroad cars with Brown-Fayro layer-loading hoists.

At railroad level the plan dimensions of the tippie (screening and boom house included) are 60x104 ft. Skylights over the entire picking-table floor provide a glass area of 1,646 sq.ft. Structural data on the entire plant, including headhouse and belt conveyor gallery, are as follows: 277 net tons of structural steel, 117 squares of No. 18 gage Armco ingot corrugated galvanized-iron roofing, 145 squares of No. 20 gage (same material as preceding item) for sheeting, and 1,113 sq.ft. of steel sash.

Of the 34 motors totaling 333 connected horsepower (boom hoists not included), 21 are equipped with Falk reducers, 12 have V-belt drives and two (layer loaders) have inclosed built-in gearing. With the exception of two Westinghouse Type CS motors on the layer loaders, all motors are Allis-Chalmers "double-cage" linestart type. Motor voltage is 440 a.c. and all power and lighting circuits are devoid of fuses.

Westinghouse Delon breakers furnish the overload protection for all circuits and individual motors, and the controls are General Electric and Allen Bradley. Rigid conduit protects all wiring and the tippie controls are grouped on one long board located in sight of the picking tables and just above the upper ends of the loading booms. Motors such as those driving the car feeder, rotary dump, flygate and belt conveyor are equipped with G. E. Thrustor brakes.

Electric service at 2,300 volts is purchased from the Appalachian Power Co. The one substation now required is situated a few hundred feet from the headhouse and close to the mine portals. The equipment consists of one General Electric 200-kw. 275-volt synchronous converter with manual starting controls, which was moved from another mine, and two new Westinghouse automatic feeder panels. Thermostats added to the converter bearings provide overheat protection.

Cars selected for the new mine stand but 20 in. above the rail yet have a level capacity of 105 cu.ft. The present equipment consists of 225 of these all-steel cars made by the American Car & Foundry Co. at the Huntington plant. Use of Cor-Ten high-tensile corrosion-resistant steel for sides, bottom, wheel hoods and cross members resulted in a car weighing 3,825 lb. against a calculated weight of 4,350 lb. for open-hearth steel. In addition to the saving in weight, Cor-Ten steel offers nearly

The new town is on a narrow flat between the highway and the Guyandotte River, which is at the base of the hill or mountain in the background



JOBS SAVED

+ By Mechanizing Basin Mining At Mahanoy City Colliery

By R. DAWSON HALL

Engineering Editor, *Coal Age*

WITH the exhaustion of the pitching portions of its Mahanoy City Colliery operations, the Philadelphia & Reading Coal & Iron Co found production there had ceased to be profitable, because the coal in the broad bottoms of the basins of the several beds was too steep in most places for cars to reach it economically, yet not steep enough for "sheen-down" pitch, and was troubled by irregular faults which added to the difficulty. This condition is not unusual in the anthracite beds, and it is one which is becoming increasingly important as the sides of the basins are worked out and only the less steeply pitching and more irregular coal remains to be recovered. Many such areas are now under water, having been left for extraction when prices rise or technique improves.

Because of this dilemma the mine was closed down for about a year. Meantime, studies were made to discover if mechanical mining could be so adapted to conditions as to make operation possible, despite flattened seams and irregular contours.

Without some form of mechanization, an early abandonment of the mine would have been necessary, with much development thrown away, many men deprived of employment and millions of tons left unused in the ground, and surrounded by caved areas as it is for-

ever unrecoverable except by sinking a shaft in the center of the basin. Such a shaft, if ever constructed, would be costly, because of caved ground, a big ventilating and dewatering problem, unfavorable approach at the surface, and all this for an inadequate tonnage. These considerations made it necessary to find a mechanical means of removing the coal while it could be reached or to leave it for the next or a later generation to tackle.

By mechanization the life of the Mahanoy City Colliery has been extended about ten years. As the company had pitching coal available, the temptation to operate it and leave the flat coal was strong, and only the possibility of mechanization saved the day. Companies have in the past mined small areas of flat coal without machinery and retrieved their losses in part by the larger volume of coal obtained from heavily pitching coal, but at Mahanoy City Colliery the coal was all either light-pitched coal or coal that had to be brought out over areas of light pitch.

Lying in a basin, mining out east and west, much like a canoe, the length of

the mining area within the company's lines is about 2,000 ft., whereas measured between crops of the Top Split of the Mammoth bed, the width is about 1,800 ft. Naturally, the width measurements for the deeper seams is somewhat greater and for the shallower seams a little less.

The basin lies just north of Mahanoy City, being separated from the Mahanoy Valley basin on the south by an extremely sharp anticline or overthrust, a dislocation so sharp that the crest of the overthrust was broken and almost entirely eroded into the Mahanoy Valley, whereas the basin still is covered by a quite sizable hill, exceeding 1,400 ft. above tide. The average pitch on the south side of the basin (northing) adjacent to the Mahanoy Valley basin is nearly vertical, this latter side facing the direction of the center of pressure that developed the several faults, but the pitch on the north side (or south dip) runs only from 25 to 30 deg. where normal.

Starting from the top the beds are:

1. Tracy—about 27 ft. thick.
2. Mahanoy—about 28 ft. thick.

Workings in basin: horizon of Top Split of the Mammoth Bed, Mahanoy City Colliery, showing lines of cross-sections A-A, B-B and C-C



MAHANOY CITY COLLIERY

ELMWOOD COLLIERY

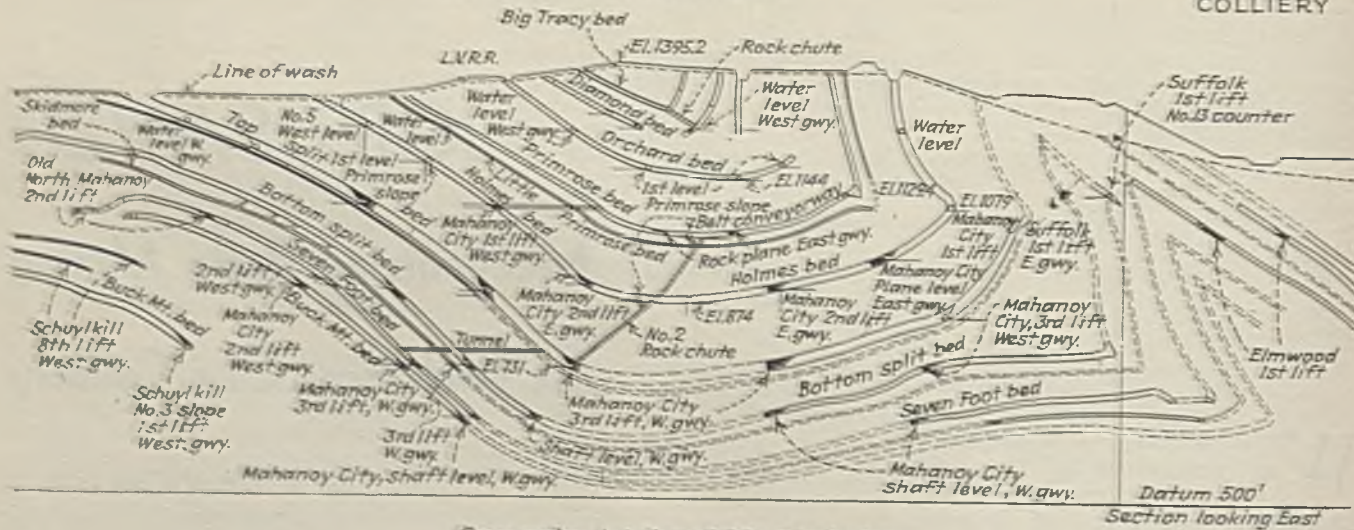

Cross-section A-A through No. 2 rock chute

3. Orchard—mined out—10 to 13 ft. thick.
4. Primrose—still working; a hard bed in this section of the coal field with thin laminations which break free from the coal and are readily removed in cleaning; 8 to 14 ft. thick, usually about 10 ft.
5. Little Primrose—mined in few places because uncertain in thickness and usually only from 2 to 3 ft. thick; used occasionally for haulage purposes; during the War was mined a little, as working opportunity was in great demand.
6. Holmes—working; all first-mined; hard, bottle-like coal; 12 ft. thick.
7. Top Split of Mammoth—working; all first-mined, except in south dip off the Belt Gangway and in an undeveloped basin west of that gangway; 20 ft. thick except at the south side of the basin, where the thrust has raised the measures into a vertical position ending in an overthrust; here the coal is as much as 75 ft. thick.
8. Middle Split of Mammoth—not much mined and only in isolated areas because of extreme irregularity; nowhere thick, it is sometimes almost absent; it was worked during the War but cannot be worked today; average thickness, 2½ ft.; used only as an approach to Top Split for ventilation and haulage.
9. Bottom Split of Mammoth—working; practically all first-mined except for a virgin area below fourth level, which is now under water; a bottle-like coal; very hard; 12 ft. thick.
10. Skidmore—working; all first-mined except for a virgin area below third level; fourth- and fifth-level coal still to be mined; this seam, in other sections generally used only for haulage, is here 6 to 7 ft. thick, of good quality, but with a divider.
11. Seven-Foot—working; all first-mined; free running in places; 8 ft. thick.
12. Buck Mountain—working; completely first-mined except below the fifth-level, where it is under water; very hard bed; 12 ft. thick.

All these beds have a high-fusing white ash. Below them may be two Pottsville Conglomerate seams, these beds being noted in a hole drilled at Kaiser's Brewery; they have not been found at the surface.

Mahanoy City Colliery was opened first in 1860 by Hill & Harris and was then known as Hill's Colliery. Mechem-

cal loading started in the Orchard bed late in 1929; in the Primrose bed in October, 1933; in the Holmes bed in December, 1934; and in the Top Split of the Mammoth bed, September, 1934.

Some of the coal mechanically loaded originates on pitches, and every effort is made to use gravity as far as possible; even so far as to develop the flat coal in the Top Split of the Mammoth bed on an artificial pitch made in the coal bed where the natural floor is too flat to cause the broken coal to slide forward. This makes it possible to bring the coal to a lateral conveyor by gravity, even when that conveyor is located some distance from a point where the bed pitches 20 to 22 deg., and coal will slide without assistance on galvanized-steel plates. These artificial inclinations are rendered possible in the Top Split because of its great thickness—20 to 75 ft.—but are not available in the other and thinner seams; nor will it be possible to establish them on the north side of the gangway, where the utmost inclination likely to be encountered is 25 deg.

In opening the Top Split area to mechanical loading, a belt gangway was driven almost due east with the aid of a Jeffrey shortwall undercutter with a 5-ft. cutter-bar, and the coal was loaded by an S-BU Joy loader onto a 16-in. shaking chute of a maximum length of 300 ft. and thus transported to a 26-in. troughed-belt conveyor running in the same direction, which carried the coal to No. 13 tunnel, where it dropped into cars.

Another similar undercutter kerfed the coal in the airway, and a similar loader placed the coal on a shaking chute which delivered it to a cross shaking conveyor, which in turn carried it to the belt conveyor. The latter, having reached its destined extension, is now 1,692 ft. between pulley centers and the gangway is 2,000 ft. long. In that

distance it drops 120 ft., or about 6 per cent, in favor of the load, but the gradient is far from regular.

The airway was driven so as to provide a 90-ft. pillar between it and the Belt Gangway, but this airway was too far from the pitching coal to have been suitable for loading direct from chutes, had the shaking conveyors for its reception been laid in the airway, so branches, at right angles to the Belt Gangway and 200 ft. long, were driven at about 360-ft. centers to the right of the Belt Gangway to give a closer approach to the base of the steeply pitching coal. Other branches will be driven eventually to the left, or north, side, but the time is not yet ripe, because the pillars in the Holmes bed above the Top Split working have not been mined and it would not be advisable to remove the coal below until the coal above has been extracted.

From the ends of these branch gangways, which are known as "laterals," straight conveyors were driven, paralleling roughly the Belt Gangway, and so directed as to follow the contour lines. These laterals, of course, being straight, did not follow the contours faithfully, but, being short, did not deviate far from them. The measures, moreover, did not elbow sharply from the bottom of the basin but rounded a little from it, so the coal could not have been expected to flow to the conveyor which was above the floor, if the chutes had been mined down to the footing of the bed.

In consequence, coal was, and is being, left and a gradient established from the mouth of chute. In every case this gradient, down which the coal would run freely on galvanized-steel plates, ultimately nosed into the floor of the almost vertical coal seam, after which the coal floor was followed until the destined end of the chute was reached.

Sometimes, it is true, especially near

the thrust, the floor could not always be distinguished from a divider or from a body of rock that had strayed into the pocket when the seam was disturbed and thickened. Folding produced a large opening into which almost anything might fall. To prove whether the rock encountered was in truth the floor, a drillhole was made in it to determine its extent. If it persisted for several feet, it was assumed that it was the true floor of the seam.

As the coal was thick, heavily pitched and, over a large area, had been disturbed in geologic time by folding and squeezing and thus was quite ready to run, the chutes were driven only 10 ft. wide; otherwise, the roof would have been too difficult to support. They were timbered with four-piece sets; the collar is 6 ft. wide between the notches of the legs, which legs are spread so as to be 10 ft. apart at the base.

Chutes are driven at 35-ft. centers and extend distances up to 375 ft. As stated, coal in these narrow breasts, pillar holes, or chutes is mined in the ordinary manner by solid shooting and cast on No. 16 gage galvanized-steel plates (36x96 in.). It travels down these chutes to the laterals.

Where the sharp anticlinal has been approached by the chutes, and the coal becomes 50 or 60 in. thick, as the chutes retreat long holes are drilled in the roof coal by an Ingersoll-Rand post drill and shot, bringing the coal down. The roof sometimes fails to fall after this is done, and in one instance an opening 120 ft. long, 80 ft. wide and 60 ft. deep was found and brought down by shooting the environing coal and roof. This was done when all men but those engaged in shooting it were out of the

mine, for fear that the void might contain a large body of gas which might be driven into the other workings when the roof collapsed. The roof settled gently, however, without any air blast.

In one place the coal over a large area ran into a chute and slants had to be driven from adjacent chutes to get

behind and above the dislodged coal. From these slants, long holes have been drilled and shot, bringing down the coal satisfactorily, though the upper part of the Top Split coal is strong and does not fall so readily as the coal in the lower part of the seam. Where the coal has thickened, part of it lies parallel to the roof, but part is on a vertical pitch paralleling the floor and all of it is disposed to run; hence it is readily dislodged by angling shots. Nearly all the coal is recovered by these means.

As two of the five branches dip away somewhat heavily from the Belt Gangway, it has been found necessary to use Jeffrey chain flight conveyors to raise the coal up the inclination to the belt conveyor. Of the five branches, one is already finished, with all the coal tributary to it exhausted; the second is being displaced by another branch more suitably located; a third and fourth are still being operated, and the fifth is being developed.

Air is being directed by brattices unsplit around these workings, but to regulate it with more precision it will be taken part of the way along an airway driven in the Middle Split and brought up by rockholes to the several splits, where it will be overcast in the coal above the Belt Gangway. This airway also will serve the north branches as soon as the time comes to develop them.

About 275 cars are delivered by the belt in the two shifts during which it

Profile C-C through No. 8 pillar chute off East Lateral, new No. 3 South Branch

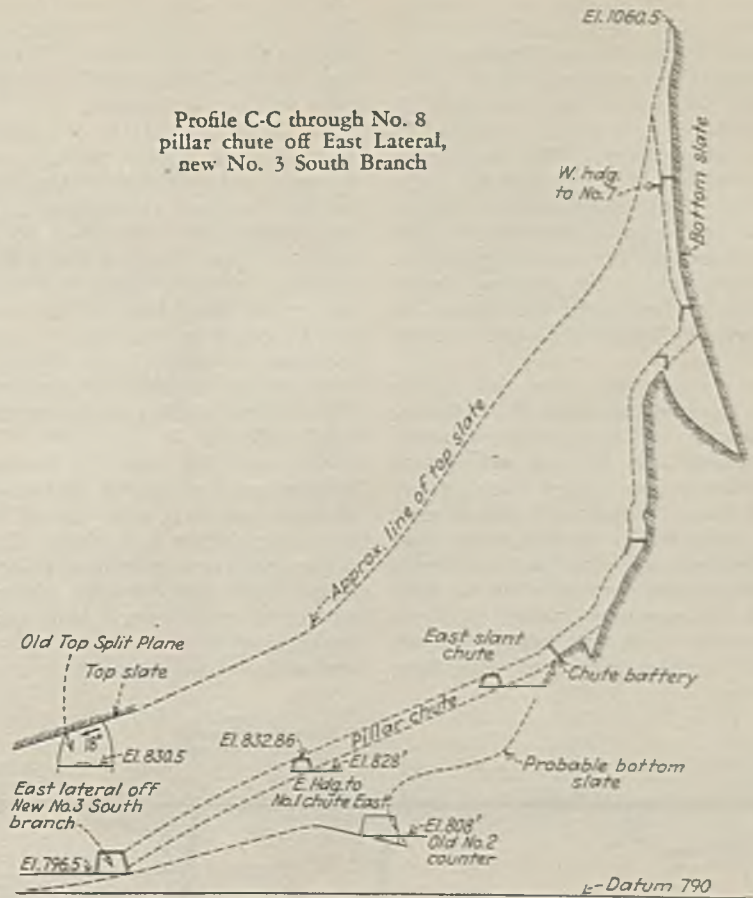

Cross-section B-B near new No. 3 South Branch of main belt conveyorway

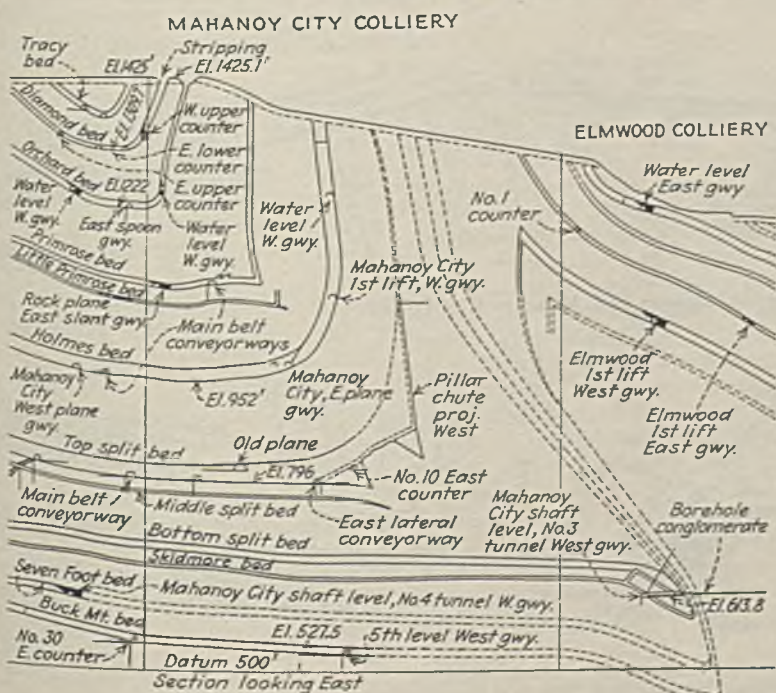

is operated, and on some days as many as 400 cars have been loaded. Steel cars of 126-cu.ft. capacity and holding $3\frac{1}{2}$ to 4 short tons, and wood cars of 97.6-cu.ft. capacity, water-level full, and of 112.6-cu.ft. capacity with a 6-in. topping, are used at the colliery. Thus loaded, the wood cars will hold 2 to $3\frac{1}{2}$ tons. The weight of clean coal derived from the mixture of clean coal and refuse is about 2.1 tons per car, for no cleaning at the face is possible in the pitching chutes. Cars are spotted under the end of the conveyor by Ingersoll-Rand electric hoists.

Where coal has been left in the chutes to give the desired inclination, the branches will be extended, new laterals driven, and the coal removed in new chutes rising toward those already driven, but as the floor rolls and, in some cases, stray bodies of rock occur near the thickest of the coal—probably brought in with the coal when the folding of the measures created a large pocket—the work will have to be arranged in those places to meet these

difficulties. Chain-flight conveyors will have to be used in the branches, and shakers in each pillar hole. In the main body of the development, no great difficulty will be encountered.

Belt drive is a Mavor & Coulson 25-hp. unit; the electric shakers are 15-hp. units and made by the same firm and by the Goodman Manufacturing Co.; the Jeffrey chain conveyors are 20-hp. units. Timber is taken along the belt-conveyor line by a 10-hp. Sullivan hoist on a track paralleling the belt, and into the branches on the flight conveyors, wherever installed, the direction of travel being reversed for that purpose. This timber handling is performed on a third shift.

For the most part, the mechanical-loading methods in the Primrose and Holmes beds are more simple, as the seams are thinner and flatter. The coal is brought from individual pillar holes direct to the belt conveyor without laterals and cross belts. However, if a heavy pitch is reached over which the coal will run satisfactorily, that part of

each narrow breast is worked as a chute, as far as possible, the chute feeding to the shaking conveyor.

In that part of the Holmes bed to the west of No. 2 Rock Chute, the transportation system comprises a 24-in. 20-hp. Joy belt, 820 ft. long, with a secondary 24-in. 15-hp. Mavor & Coulson belt, 600 ft. long, the two being connected by a 15-hp. Joy shaking conveyor, 200 ft. long. The transportation line has been extended 250 ft. from the tail pulley of the secondary belt by a 10-hp. Vulcan electric shaker. This addition was made necessary by a turn in the syncline.

In addition, a lateral is connected to the transverse Joy shaker. Here a 15-hp. electric Cosco shaker, 300 ft. long, brings coal from chutes on a sheet-steel pitch. The coal is delivered by the primary belt conveyor to the No. 2 Rock Chute, to be described later.

To the east of this chute and in the same bed, a 15-hp. Joy drive actuates a 24-in. belt, 950 ft. long, fed by a 15-hp. Cosco main shaker 220 ft. long. All this

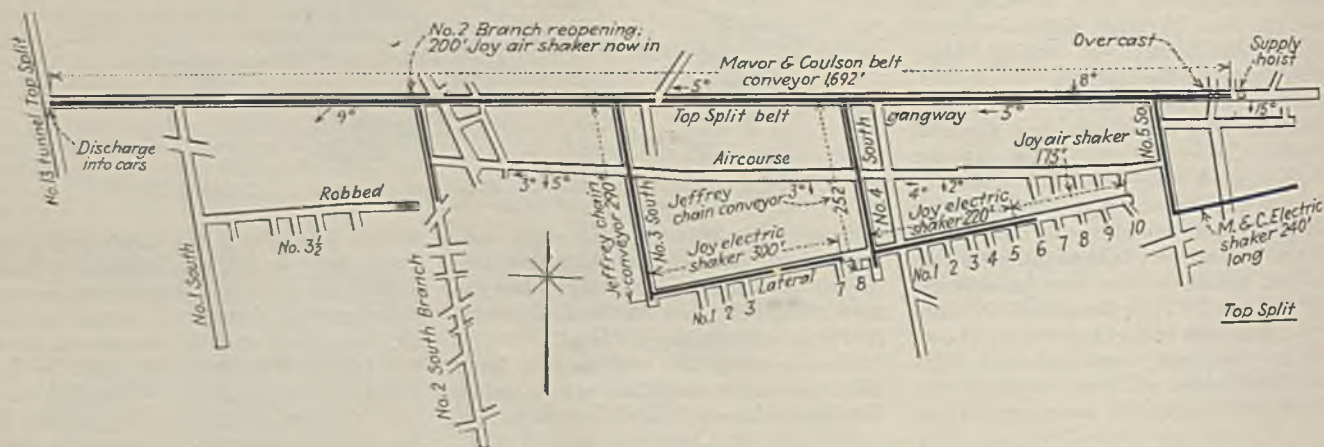

Mechanization, Top Split Bed, Mahanoy City Colliery

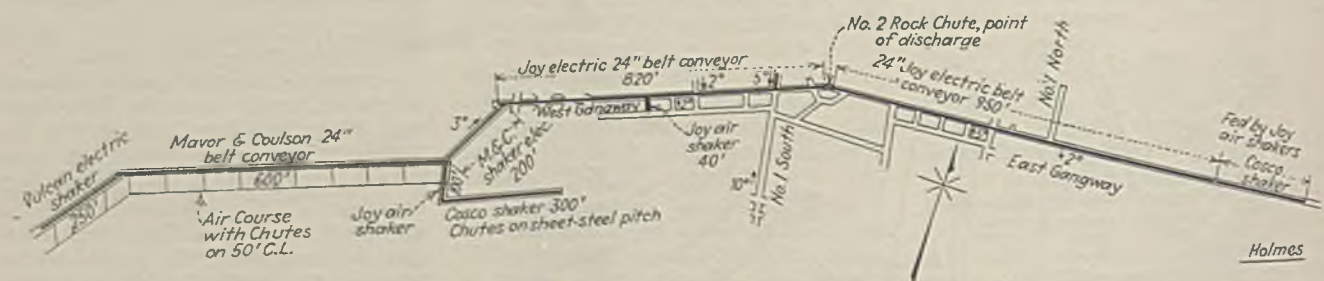

Mechanization, Holmes Bed, Mahanoy City Colliery

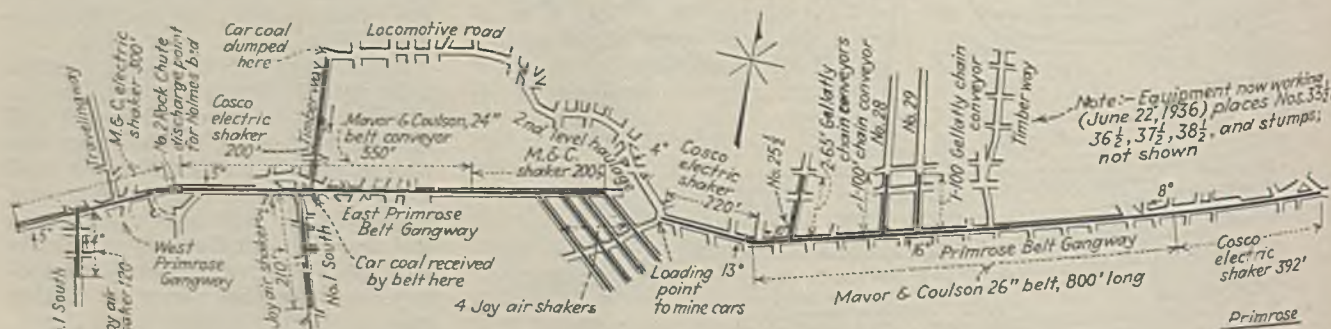

Mechanization, Primrose Bed, Mahanoy City Colliery

territory has been first-mined, and pillar holes are being driven northwardly at right angles to the main shaker; the coal is conveyed from these by 10-hp. Joy air shakers. The Holmes operations have completed their development and are beginning to start on a retreat basis.

In the Primrose bed on the west side of the No. 2 Rock Chute is a 15-hp. Cosco electric shaker, 300 ft. long, fed by two 10-hp. Joy air shakers, which have developed pillar holes for a distance of 300 ft. reaching to the lift above, and these are now in retreat. On the east side of No. 2 Rock Chute is a 20-hp. Mavor & Coulson 24-in. belt conveyor, approximately 550 ft. long, fed by a 15-hp. Cosco shaker, 250 ft. long, which receives coal from four pillar holes now retreating and employing 10-hp. Joy air shakers.

Another development in the Primrose bed was made from the Primrose slope, second level, East Primrose gangway, starting from the point where that gangway turned around the end of the trough; the development followed the changing alignment of the syncline to the point of outcrop, necessitating the use of several conveying units.

The primary unit is a Cosco 15-hp. electric shaker, 220 ft. long; the secondary transportation unit is a Mavor & Coulson 24-in. belt conveyor, originally 1,192 ft. long; beyond this point was a 15-hp. Cosco electric shaker, 250 ft. long, which in turn was fed by a Joy air shaker of equal length. The pillars have all been mined with twelve d.c. powered Gellatly chain conveyors varying from 50 to 125 ft. in length, at which point the bed pitched enough to carry the coal to the pans.

Coal in the basin has been retreated from its eastern extremity, taking along with it pillars hitherto left to support a timber-supply road. Thus the belt conveyor already has been shortened to 800 ft. and the Cosco shaker by which it was fed has been torn down and re-erected in the straight length of gangway which the inner 392 ft. of the belt conveyor thus vacated. Other lengths of the belt conveyor will be taken up in turn and the shaker conveyor will be moved back until it reaches the main loading point.

This coal originally was tributary to a slope in the Primrose bed, on which coal was hoisted to a water-level haulage in the same bed. This latter was located immediately over the south dip pillars tributary to the area to be robbed, and it became necessary to eliminate both the slope and the haulage artery, so that the underlying pillars could be removed.

To this end a combined conveyorway and dump chute was constructed 800 ft. west of the loading point. The coal is loaded into cars at the loading point and transported by locomotive to an end dump over a chute, from the bottom of

which it is loaded onto a 15-hp. Cosco electric shaker, 220 ft. in length, which conveys it, in turn, to the main East Primrose belt leading to No. 2 Rock Chute.

This rock hole receives, therefore, all the coal mined in the Primrose and Holmes beds. It runs from a level of +730 ft. in the Top Split to +1,016 in the Primrose basin and is 450 ft. long to the Primrose bed, cutting the Holmes bed at an elevation of +881 ft. The pitch of the rock hole to the Holmes bed is about 40 deg., and that between the Holmes bed and the Primrose is about 50 deg.; the chute width is 20 ft.

One battery is placed above the Holmes bed and another above the Top Split, so that coal can be dumped from either the Holmes or the Primrose bed without interference of coal from one source with coal from another. If the rock chute had not been divided by a battery above the Holmes bed, it would have been necessary to keep the chute full up to the Primrose bed to protect the coal from degradation, and thereby the Holmes bed coal would have been entirely shut off.

On one side the rockhole has a travelingway, and on the other side, a timber hoistway with a Brown-Fayro

25-hp. electric hoist. Thus all the coal from the Primrose and Holmes beds arrives at the Top Split bed and is dumped into cars, hauled by trolley locomotives to the Gunboat, or skip, Slope, a distance of 4,000 ft. Coal from the belt conveyor in the Top Split bed is hauled 3,800 ft. from the belt discharge to the bottom of the Gunboat Slope, which is 1,125 ft. long to daylight. The Upper Primrose workings are producing 75 cars per day and the entire output from the Primrose and Holmes workings is about 225 cars daily.

A mechanical production of 500 cars per day out of a total output of 1,000 cars daily comes to the "breaker" (which now serves as a rough cleaning point) and is transferred to railroad cars to be cleaned and sized at the St. Nicholas central breaker. Machinery will be moved to the lower beds as fast as with proper sequence it becomes feasible to use it on such coal as pitches too gently to be operated without mechanization. The units are all actuated by 440-volt a.c. current except as noted. Current at 2,300 volts a.c. is carried into the mine and stepped down at substations to 440 volts. The trolley wire carries a direct current of 250 volts.

HOW TO STORE

+ And Use Mine Lubricants*

By WILLIAM HURST

*Superintendent, Princeton Mining Co.
Princeton, Ind.*

LUBRICATION is no longer the hand-oiling, hit-or-miss, all-waste job of the earlier stages of the industrial era. With machines operating at higher speeds and carrying greater loads, modern lubrication must be both positive and continuous. Moreover, in large systems, where the oil is used over and over again, the problem of maintaining the quality of the lubricant in service must be met. All the care exercised during refining, transportation to the consumer and by the latter to prevent contamination before use may be wasted if the lubricant is placed in a system where it may readily become contaminated.

This contamination may come from old oil sludge or similar material lodged in the lubricating system or from some foreign matter which enters after operation is started. In either case, however,

unless removed, the contamination will reduce the effectiveness of the lubrication. Maintenance of quality of lubricants in service, therefore, presents two phases: (1) Preventing entrance of foreign materials and maintaining operating conditions so that deterioration of the oil itself will be at a minimum, and (2) removing contaminating substances as soon as they are formed in, or enter into, the lubricating system.

Because oil and grease vary in their physical characteristics and handling, their treatment will be considered separately. As a rule, greases are used only once. In most cases, therefore, maintenance of their quality resolves itself into the avoidance of contamination. Contamination may be minimized by keeping the covers on grease boxes tight; keeping a sufficient supply of grease in the bearings so that it always will be working out, preventing the en-

*Abstract of an address entitled "Use and Storage of Oils," before the Indiana Coal Mining Institute, Evansville, Ind., June 20, 1936.

trance of dirt; seeing that bearings are so protected that water will not get in and wash out the grease; and using grease cups or pressure fittings.

When bearings are exposed to the weather or when the lubricant is used on machines where water is present and where it is not possible to avoid contamination, it usually is necessary to use special water-resistant greases. Grease boxes with loosely hinged covers invite contamination because the cover, thrown back when the box is filled, is not always closed when that operation is completed. To eliminate this source of contamination, use spring covers which must be held open for filling.

Some types of service demand the highest grade lubricating oils. While such oils will continue to lubricate even when they contain a considerable amount of contamination, excess bearing-wear may result. Such damage to expensive machinery is often many times the cost of the lubricant and may necessitate still more costly shutdowns. Water and dirt are the most common contaminating matters. The method for keeping these out and for preventing the formation of other contaminating substances varies with different types of equipment. The three methods most commonly employed in the removal of impurities are:

1. Gravity settling or precipitation,
2. Filtration, and
3. Centrifugal force.

Basis of Gravity Separation

The first method is based upon the difference in specific gravity between the oil and the impurities. To accomplish the best separation, long standing without undue agitation is desirable. Application of heat assists separation and, in some cases, precipitating chemicals are used. Filter systems with settling chambers usually heat the oil and slowly pass it over shallow settling trays. In this way very little agitation occurs and the foreign substances have to settle only a short distance before being precipitated out. Substances so removed are water (not moisture), the larger particles of dirt and some sludge. Some emulsions will break on standing or when heat is applied; others may separate only partially or not at all. Gravity settling of this type when used alone, however, is only of partial benefit in removing contamination; used in conjunction with other methods, it materially aids the latter in functioning properly.

In the filtration method, the oil passes through a material of fine mesh, such as felt, and the suspended solids are retained on the filter cloth. The area and mesh of the filtering media, the viscosity of the oil, the nature of the impurities to be removed and the quantity of oil to be conditioned are all factors which must be considered. Although heating the oil reduces its body and so facilitates more rapid filtration, some sludge ma-

terials are more readily dissolved in the oil when the temperature is high and, therefore, are best removed when the oil is cold.

Some oils contain certain sludges and emulsions which are very fine and stable and which are not removed by gravity settlings. These materials are dense enough to clog up a filtering cloth in a very short time. To remedy this the cause of the sludge formation should be eliminated. Where this is not practicable, separation by centrifugal means or by coagulation generally will give improved results. In most cases, however, filtration can be relied upon to completely remove dirt and some sludge.

Blotter presses, in which the oil is passed through blotter paper, are used for the final filtration of transformer oil where it is reclaimed by the gravity filtration-type system. These presses remove the last traces of moisture and extremely fine particles of foreign material, giving the oil the required high breakdown value. Care must be taken, however, to see that no water reaches the press, because if holes are made in the blotters, filtration will not be accomplished.

Centrifugal force has been used for many years to quickly separate substances of different specific gravities. In a centrifugal separator the impurities, being heavier than oil, are quickly thrown out and collect in a different section of the separator from the cleaned oil, which is continuously discharged. This system will remove water, moisture, dirt, sludge and soaps which are suspended in but not dissolved in the oil. It also will separate many emulsions.

Keep Performance Records

Coagulation consists in treating the oil with chemicals so that the dirt, oil-soluble soaps, oil-soluble sludges and similar materials will be precipitated out in the form of an insoluble sludge. This process requires heating the oil to the proper temperature, adding the chemicals in the correct quantity and thoroughly agitating the mixture, after which gravity settling, filtering or centrifugal force may be employed. Purification by this method requires skill and care in manipulating and, in many cases, the assistance of a chemist. For these reasons, and on account of the expense and supervision necessary, only rarely is a special process of this nature installed, and then only when large quantities of oil are to be handled.

No matter what type of oil is to be reclaimed, performance records should be kept. Whether or not the recovered oil lubricates as satisfactorily as new oil is of greater importance than the cost of reclamation. No matter how low the cost of restoration might be, freedom from lubricating difficulties is more essential. For the various types of reclamation systems to function properly

they must have a competent man in charge of their operation. His duties are to see that the unit is functioning properly, is cleaned periodically and the reclaimed oil is up to standard. It is only when high quality oil is reclaimed in this manner that thoroughly satisfactory results will be obtained.

There are so many factors to be taken into consideration in determining the size and location of lubricating storage that each individual installation must be considered separately. Sheet iron and sheet steel are satisfactory materials to use for the fabrication of storage tanks. Galvanized tanks should never be used because of the action between this material and oils, especially compound oils.

Storage equipment may be only for the storage of lubricants or it may be used for dispensing purposes as well. In the main, oil storage lubricants may be kept in barrels or small packages. When lubricating oils are used in large quantities, storage tanks of sufficient size to receive tank-car shipments may be installed. Whether this tank-car storage may be profitably employed or not, and if so, the size to be used depends upon:

1. Amount of lubricant used per year.
2. Character of the lubricant.
3. Daily consumption of lubricant. If large, could daily or weekly shipments in barrels be more advantageously employed than tank-car shipments.
4. Space available.
5. Availability of steam for unloading in cold weather.
6. Factors governing the proper location of such storage.

Where to Store Tank Cars

There are certain locations that are desirable for tank-car storage, but conditions are not always such that this space may be used. The preferred locations, and some of the factors that have to be considered, are:

1. Tank-car storage should be as close as possible to the unloading point, to avoid excessively long unloading lines.
2. It should be as close as possible to the center of distribution, so that distributing lines or routes of portable distributing tanks may be as short as possible. It seldom happens that these two requirements can be completely met; and where a compromise is necessary it is preferable to locate the main oil storage so that distribution is as simple and inexpensive as possible.
3. Tanks should be either located low enough so that the tanks may be emptied by gravity, or high enough so that the oil will flow by gravity to the point of distribution or use, or into the portable dispensing tanks. Pumping both into and out of the storage tanks should be avoided if possible.
4. Means of heating tank-car storage in cold weather should be properly provided, as lubricants become very heavy and difficult to pump at low temperatures. Heating coils may be placed directly in the tank. If this method is used, the coils should be made from a single piece of pipe so as to avoid any connections inside the tank

through which water or steam might leak into the oil. In general, only sufficient heat should be supplied to heat the oil to between 70 and 100 deg. F., which usually is warm enough to allow pumping. Continuously kept at much higher temperatures, some lubricants undergo undesirable changes. Hot water is sometimes used in place of steam to control the temperature more readily. Heating coils of this type are always used in outdoor or underground storage.

Indoor storage is generally warm enough so that only the heavier bodied oils will require additional heating, which can be supplied by a steam coil located on the outside of the tank, preferably underneath. Outside storage is at all times undesirable, due to the contamination formed by excess breathing. This is particularly noticeable in cold weather. To avoid this, lubricants for use during the winter are many times purchased in barrels or barreled before cold weather arrives if outside storage tanks are used, and stored indoors where an even temperature may be maintained.

5. All storage tanks should be so located as to avoid subjecting the lubricant to extremely high or low temperatures. Compounded oils may separate when kept at too low a temperature and fluid greases may

large storage tanks. By such an arrangement supervision is simplified.

Barrels should be stored inside so that brand names will not be obliterated by action of the weather and so that wide variations in temperatures with subsequent contamination will not be encountered due to "breathing." If barrels must be stored outside, a sheltered place should be used and the barrels kept on their sides so that water and dirt will not collect on the head. It is also desirable to keep a minimum of stock on hand under these circumstances and to use the oldest stock first. This latter procedure is always good practice. Lubricants of any nature are combustible. Oil-soaked rags, waste and other material should be kept in closed metal containers, both for cleanliness and fire prevention. Fire extinguishers should be located at strategic points.

Frequent variations in temperature, especially noticeable in the spring and fall, though not necessarily reaching extremes, cause "breathing" to take place in any storage container. In other

in a dusty or dirty location. In all cases it is advisable to cover the openings with a very fine mesh screen, so that as much of the dirt as possible may be kept out. Where the temperature varies greatly, barrels also will "breathe" and accumulate moisture and dirt unless the bungs are airtight. If it is necessary to store barrels outside they should be placed on their sides; otherwise rain, water and dust that accumulate on the barrel top will be drawn in through the bung hole instead of air when the barrel cools, greatly increasing the rate of contamination.

As much, if not more, care should be taken in the storage of oil inside the mine as outside, for the reason that there is more danger of fire hazard. Men do not have as many avenues of escape as they have outside the mine. It is very hard to have a set rule, for each mine has different conditions with which to contend. There should be fireproof stations built, the size depending on the quantity of oil to be stored at one time.

In the King Station mine there have been different systems tried out. As this is a 100 per cent mechanical mine there is a large quantity of hydraulic and lubricating oils used. When we first started on mechanical loading, we tried taking inside barrels of oil and draining them into cans and then taking them to loaders. This, however, proved to be unsatisfactory, as there was a large amount of contamination and waste. Next we tried hand pumps that fit in barrels such as they use at oil stations, but this did not prove to be so good a system. Then we built trucks in which to haul oil in the mine.

To Use Motor-Driven Pumps

These trucks are taken on top and four barrels of oil loaded on them; two barrels of hydraulic and two barrels of lubricating oil. The oil men have a motor with which they take the truck in and grease the loaders. We have had some trouble with cars being left in front of loaders. To pour or shoot oil into a loader with a hand pump or squirt gun is very slow, so we are going to put motor-driven pumps on these cars and about 30 or 40 ft. of hose.

Two sets of hose and two different pumps will be necessary, as there are two different grades of oil. We use a steam cylinder stock for Joy clutches both in the front and back ends. This oil has a flash of 490 and viscosity of 155 at 250 deg. F. Our hydraulic oil is a red oil No. 17, flash 405, viscosity at 100 deg. F. So there is a difference in the pour points of these oils which will necessitate a different pump for each oil. I think this system with the hose will prevent the cars from being in the way and the pumps will upspeed the oiling. They will be equipped with a bypass set at a certain pressure so that the pumps can run continuously while the greaser is greasing the loader.

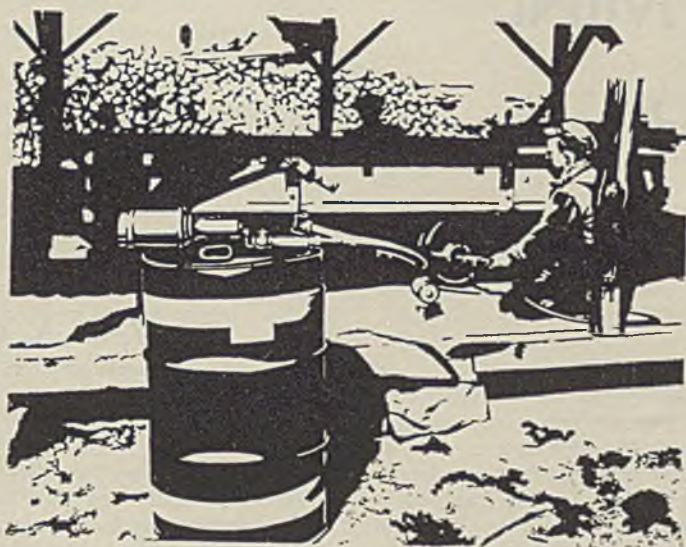

separate when excessively heated. All lubricants are so manufactured as to be stable at normal temperatures and under the operating conditions for which they are desired or designed.

6. Rapid variations in temperatures which cause "breathing" should be avoided. This is essential in keeping to a minimum water and dirt contamination.

The factors which influence the size and location of large tank storage are of equal importance in considering space for the storage of lubricants in barrels or smaller packages. Since the barrel storage should be in close proximity to the receiving platform and centrally located to reduce trucking distances to points of use, it usually will be located in the same building or adjacent to the

words, as temperature is increasing an expansion takes place and part of the air in the container is driven off. When the temperature falls, air is drawn back in. This air contains moisture some of which will condense on the inside of the barrel or tank and settle to the bottom. As this moisture is under the oil it is not driven off when the temperature again rises, and remains there. The more frequent and the greater the air space, the more water will accumulate.

The air drawn in due to "breathing," as well as that which replaces the oil withdrawn from storage tanks, contains dust and dirt in addition to moisture, which also find their way into the tank. For this reason vents, besides being in a sheltered place, should not be located

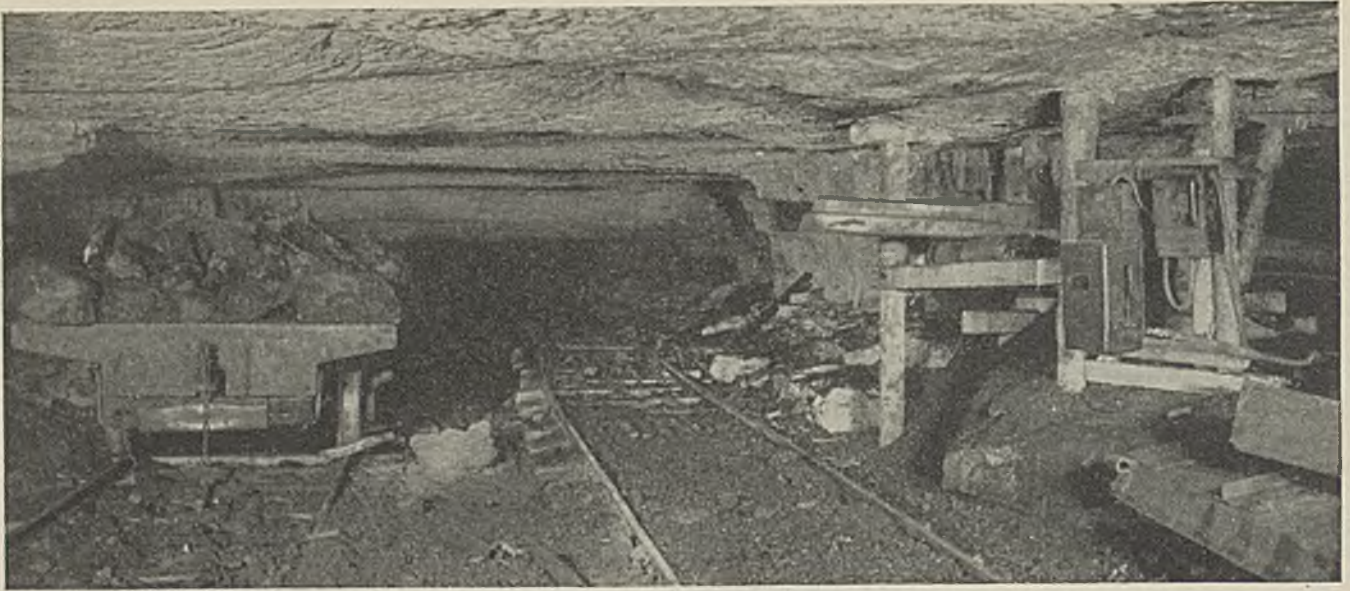

Double tracks facilitate handling empty and loaded cars under the conveyor discharges at Peerless No. 3 mine

NEW PEERLESS MINE

+ Turns to Conveyor Loading

For Working Thin-Seam Coal in Utah

By IVAN A. GIVEN

Associate Editor, Coal Age

WITH thick seams of coal predominating, Utah until recently has concentrated on track- or caterpillar-mounted loaders in mechanizing its mines. The thinner beds, however, have attracted increased attention in late years, and the pioneer conveyor installation at the No. 3 mine of the Peerless Sales Co., in the Spring Canyon district of Carbon County, presages additional installations in the field. At the No. 3 mine, shaker conveyors are employed in mining a seam averaging 42 in. in thickness, which is broken down with Cardox.

The seam at Peerless occurs high in the mountain and is reached by an incline approximately 3,000 ft. long on a grade of approximately 14 per cent. Dip of the seam averages 7 per cent almost due north. The coal, averaging 3½ per cent ash, is blocky in character, with the result that lump over a 3-in. screen amounts to 68 per cent of the total shipments. The roof in the mine is a thick, strong sandstone and the floor also is made up of the same material.

Rooms are driven and the pillars are extracted on the advance at No. 3 mine,

and, in addition to the entry-driving unit, two conveyor units are employed in room work on each entry. One of the two latter units is used to advance a room while the other is engaged in robbing back the pillars in the next preceding room. Room entries consist of two headings 20 to 24 ft. wide on approximately 62-ft. centers. These entries are driven just far enough off the strike of the seam to give a grade of 1½ to 2 per cent, as far as possible in favor of the loaded cars. Consequently, the entries are not driven on sights but instead follow as far as practicable the contour of the seam to give still greater assurance of a favoring grade.

The two headings making up an entry are advanced alternately in cycles of 100 to 300 ft. With the original air-driven equipment, the standard advance was 100 ft., or from one crosscut to the next. With the electrically driven equipment later adopted, advances of 300 ft. have been made, with brattice lines to carry the air to the face. The lower heading in all cases is the haulage road. In the cycle in the two headings, the haulage side is first advanced 100 to 300

ft., as the case may be. As the face moves forward, the crosscuts are driven to the proper depth with cross conveyors, after which the conveyor unit is moved over the aircourse side.

With the conveyor unit working in the aircourse bottom, the haulage heading is then lifted for height. In this operation, performed by hand, approximately 2 ft. of the bottom is taken up to a width of 16 ft., sufficient to allow the installation of a double track opposite the working places to facilitate the handling of loads and empties past and under the conveyor units. This double track, laid with 20-lb. rail on wooden ties, is kept back to a minimum of four rooms, and is advanced from time to time as the rooms are worked out. Main-line track up to the double-tracked section is laid with 40-lb. steel. To further facilitate the handling of cars, crossovers are installed in the double-tracked section just ahead of each crosscut. These crosscuts are driven opposite each room neck to permit the

conveyor to be carried over to the haulage heading. The bottom is left down in the aircourse, and most of the material taken up on the haulage side is loaded out for disposal on the surface, although some is stacked on the benches on each side of the place. And while Cardox is used for breaking down the coal, the bottom rock is shot with a permissible rock powder after being drilled with air drills. Clear height over the rail after bottom lifting averages $4\frac{1}{2}$ to 5 ft.

Rooms at No. 3 mine are driven on 100-ft. centers, which brings the room necks opposite the crosscuts on the entry. Room necks are approximately 16 ft. wide and four or five cuts deep. Width of the rooms is 40 ft., and the places are driven up the pitch, which places the faces approximately on the face of the coal. Conveyor units are installed on the center lines of the rooms, and two rows of timbers on about 5-ft. centers are set on each side of the conveyor, although the top is exceptionally good. Face conveyors are not employed, as experience has shown that the coal can be hand shoveled out of the corners to better advantage and more cheaply.

Standard crews for a room unit comprise thirteen men, as follows: machine runner and helper, two drillers, one shotfirer, one timberman, six loaders and one car trimmer. Each conveyor is accompanied by a shortwall cutting machine (Sullivan, CE-7) with $6\frac{1}{2}$ -ft. cutter bar—a 7-ft. cutter bar is installed on one entry machine. Little Giant and Dooley Bros. electric drills are employed for putting in shotholes. Entries are driven on contract by a crew of four men, who do all the necessary work required in their advancement. Room crews alternate between the unit engaged in driving the room and the second unit engaged in pulling the pillar in the preceding room. Thus one face can be loaded out while the other is being cut, drilled and shot.

Upon completion of loading operations at the face, it is cleaned up and the machine men, drillers and shotfirer cut and drill the place and load the holes with Cardox cartridges. In the meantime the timberman is extending the timber lines and making the conveyor ready for the addition of another pan. Rooms are shot with six holes as a rule, one on each rib and the others evenly spaced across the face. Cardox cartridges used have a diameter of 2 in. and a capacity of 80 cu.in. These replaced the B-37 Cardox cartridge with a capacity of 37 cu.in., and proved advantageous through a substantial reduction in the number of holes required to break down a place. With Cardox, coal can be broken down on the shift, whereas with explosives shooting on the shift is prohibited by State law, or in fact at any time when men are in the mine. Entries generally are shot with five holes, the greater proportionate number aris-

ing out of the fact that these openings are advancing on the butt cleat of the coal. Upon completion of the other operations in a place, the holes are fired. The place is then inspected and made safe, after which it is ready for the loaders, who shovel directly onto the conveyor.

When a room is driven to its full depth, which may vary from 300 to as much as 500 ft., a slant is driven across the end of the pillar at an angle of approximately 30 deg. As operations on the lower entry normally are kept in advance of the upper entry, this slant is in solid coal. A cross conveyor is used to drive this slant and subsequently is employed in working the pillars down to the entry stump. This cross conveyor discharges into the main conveyor used to drive the room, which is shortened from time to time as required. As the pillars are removed, the space behind them is filled with timbers on approximately 5-ft. centers. Generally, however, the roof does not begin to break until the pillars have been robbed out down to the entry stump, and even if a break does occur before that time the fracture line is such (Fig. 2) that the break does not extend to

the face. Time required to move the face conveyor up after each cut is relatively short, and the operation has been performed in 20 minutes.

Conveyor drives (Eickhoff and Vulcan of Denver) usually are mounted on concrete bases and additional rigidity is insured by using the holding jacks normally accompanying the drives. The discharge ends of the units are carried up to car height on wooden rollers. Cars are controlled under the conveyor discharges by wire ropes passed around a sheave mounted up the heading to a small hoist. Trips are handled between the loading stations and the landing at the top of the incline by a trolley locomotive. With the exception of the locomotive, all electrical equipment operates off a 440-volt a.c. circuit consisting of an armored 3-conductor cable to which the rubber trailing cables to the various units are connected.

Under normal market conditions, mine output ranges from 350 to 400 tons per day of two shifts. Entry advance averages about four cuts per shift, and the record output from an entry crew of four men was 38 cars in one shift. Operations at the mine are under the direction of Jack Jones, superintendent.

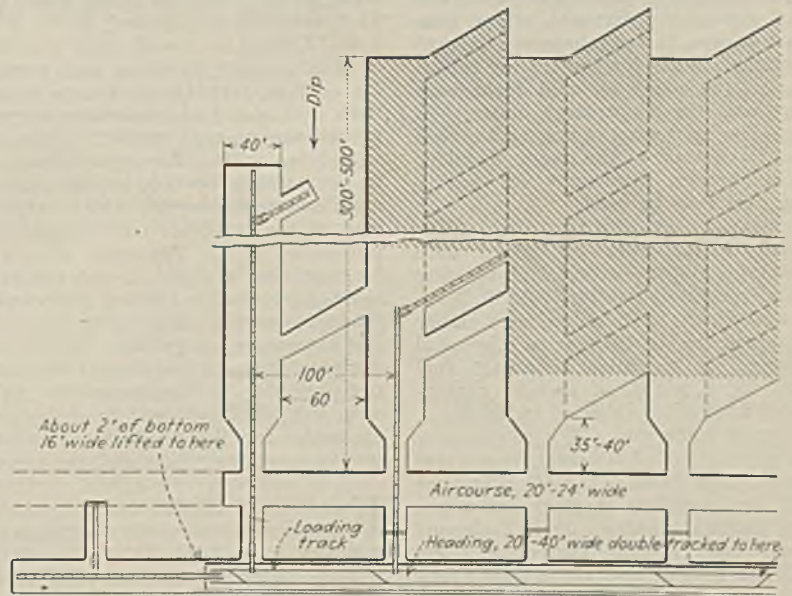

Fig. 1—General plan for advancing entries and rooms and robbing pillars at Peerless No. 3 mine

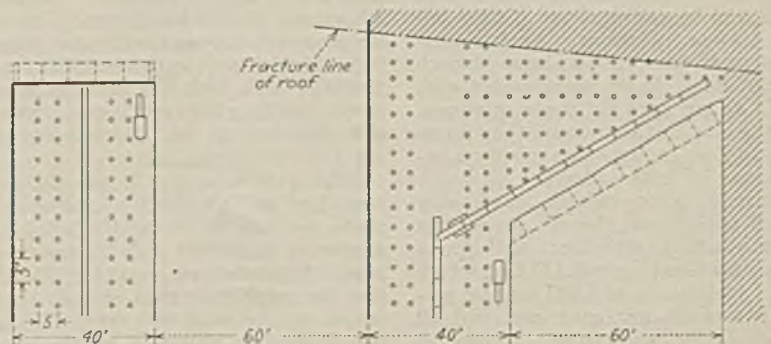

Fig. 2—Timbering, drilling and conveyor plans in rooms and pillars

NOTES

From Across the Sea

NON-COKING dusts often have been advocated by coking experts for improving the product in coke ovens, it being asserted that they replace a small number of large crevices which weaken the coke by a larger number of small crevices that do not weaken it materially; but these have been added to the charge as a whole and have not been advocated for their absorptive quality. A British patent recently has been awarded to Simon-Carves, Ltd., and J. T. E. Preston, Stockport, England, for a method which applies the non-coking material solely to the top of the oven charge. Two inches or more of such non-coking or feebly coking material is applied to the charge after the latter has been spread by the leveling machine, and the charge is then reveled, mixing the added material with the top of the coal already in place. After sealing and heating the oven, the tarry matters rising in the coking process are absorbed by the non-coking material, which usually, of course, is coke breeze. Instead of "sponge" being formed on the top of the coke, the mass is solid from base to top, and the uppermost material is said to be of equal value with that formed in the rest of the oven. In place of coke breeze, anthracite or weakly coking coal may be used.

COLLOIDAL fuel—oil mixed with coal ground to a colloidal or near colloidal condition—declared A. B. Manning and R. A. A. Taylor, in a paper read before the Institution of Chemical Engineers, is the most compact fuel known, for if a coal of specific gravity 1.35 and a calorific value of 14,500 B.t.u. per pound is made into a 40 : 60 per cent mixture with oil of 0.9 specific gravity and a calorific value of 19,000 B.t.u. per pound, the resulting mixture has a potential thermal content of 11.2 therms per cubic foot, whereas that of oil alone is 10.7 and that of coal alone only about 7.2. Such mixtures will not fire spontaneously, and, as their density is 1.04 in the example quoted, they can be prevented from being fired from external sources by a shallow water seal and will sink and be extinguished if they fall on the surface of water. Such a seal also reduces evaporation loss, though this is not likely to be considerable with such oils as are used for these mixtures. In moisture and ash contents they naturally occupy an intermediate position between those of coal and oil.

Low-grade crepe rubber, preferably aged and milled into the oil, makes the most satisfactory stabilizer, said J. L. Strevens, National Coke & Oil Co., which produces weekly about 1,000 tons of colloidal fuel of 50 per cent coal and 50 per cent oil for processing. It can be used in small proportions and yet will

give a suitably strong, low-shearing gel structure to any mineral-oil product; it, however, is not so suitable for use with coal oils. His company is using coal oil with light creosote oil for the making of colloidal fuel.

Writing in *Colliery Engineering*, Mr. Strevens advocates that at present colloidal fuel be made of 30 parts coal to 70 parts oil, because such a mixture is more fluid and better suited to present equipment than the more equal mixtures. After the 30 : 70 mixture has established itself, it will be possible to strive for one that will use more coal. The 50 : 50 mixture is too viscous for present-day consideration. Thirty per cent of coal in finely pulverized form added to fuel oil increases its volume 28 per cent and still produces, he says, a concentrated fuel of approximately the same heating value as one made from a mixture of 50 per cent coal to 50 per cent oil, but instead of its viscosity being from 24 to 32 times that of the fuel oil, it is only 9 to 10 times as viscid, thus permitting of much easier handling and pumping. Its cost of preparation would be lower than that of a fuel containing a greater percentage of coal, and its ash content would be lower. Its appeal also would be greater, for it would appear more like medium-grade fuel oil, which cannot be said of the mixtures that contain more pulverized coal. The price also would be near that of fuel oil, and the economies of production of such fuel could be made reasonably close to those of making its heavier competitor. Mr. Strevens declares that for the liquid constituent, not only fuel oil from petroleum may be used but oils from coal or shale, giving an outlet for the products of low-temperature carbonization and for creosote.

FOUNDRY COKE should have a high graphite content, so that the foundry iron will pick up carbon. It also should have a high carbon content, as that increases calorific value and calorific intensity, according to W. E. Mordecai, speaking at a meeting of the Institute of British Foundrymen (Newcastle Branch) and the Coke Oven Managers' Association (Northern Section). Quantity of graphite in coke increases with the temperature at which it is carbonized, but, unfortunately, such high carbonizing temperatures usually yield small coke, although this difficulty can be overcome by blending and oven design.

Sulphur in coke may be associated with iron, lime and alkalies, as sulphite or sulphate, or may be in solid solution or in a state of adsorption with the carbon complex. Some believe, says Mr. Mordecai, that the sulphur in coke is most deleterious when associated with iron. The quantity of sulphur picked up by the iron depends on the quantity in the coke, on the

form in which it occurs in that fuel, and on the nature of the coke ash and sulphur in the metal charged.

It would appear, Mr. Mordecai says, that low-sulphate irons will take up more sulphur than high-sulphur irons. As silicon forms volatile silicon sulphite, high-silica irons probably are less likely to pick up sulphur than low-silicon irons. Sulphur is likely to be incorporated in the iron if the slag contains ferrous oxide and lime, if the melting zone in the cupola be deep; if the manganese content be low; and if temperature of metal and slag is not too high. Addition of sodium carbonate or excess limestone will reduce sulphur "pick-up." Used in the cupola instead of in the ladle, sodium carbonate decreases the quantity of sulphur picked up by the iron, not so much by removal as by prevention. Sulphur, declared Colin Gresty, might be advantageous if properly balanced with manganese.

As content of coke, Mr. Mordecai added, may be lowered to such an extent as to reduce crushing strength, though this is not a common experience. Certain coals are cleaned too completely, removing the silica selectively and lowering the fusibility of the ash. Exceptionally low phosphorus usually is not demanded, and its influence on special metals is conceivably determined by the form in which it is found. In some foundries the effect of phosphorus is negligible because a smaller quantity in proportion of coke to metal is used than in blast furnaces.

As to size of coke, opinion varies. Large cupolas have changed from large to small coke with detriment. A 2x4 in. size may be quite suitable for small cupolas, as this size of coke has a higher shatter index than coke of larger dimensions.

BY ISOLATING an acid from coal and converting it into a technical fat, says *The Iron and Coal Trades Review*, soap and fatty material for lubricants have been made, and a new factory at Witten, Germany, is planned to utilize this discovery by the Henkel and Persil interests, to be known as the Deutsche Fettsäure-Werke G.m.b.H.

BAGS of hessian cloth (a coarse sacking of hemp, or hemp and jute) is being used in a mine at New Cumnock, Ayrshire, Scotland, for packing an advance longwall conveyor face in an 8-ft.-6-in. seam at a depth of 900 ft., according to James Carson, in a communication to the South Wales Institute of Engineers. The bags when full weigh about 60 lb., measure about 5x9x27 in. and are built into packs with the long sides parallel to the face. The bags are made with a seam down each side but with no seam along the bottom. They are tied with two ears at the mouth, as they have been found to give better results than when tied with a single ear, for they can be built closer together in each layer when thus closed. When laying stretchers the bags are placed so that the seams are at top or bottom, so that in no case is a seam exposed to the side of the road.

The New Cumnock bag packs do not bulge measurably under heavy load and, where the packing rock is of poor quality, give better results than rock packwalls. Faces had advanced 4 ft. 6 in. daily since November, 1934, and it had

not been necessary to repair the roads, which are supported on steel arch girders of 4½x5-in. section set at 3-ft. intervals. The clear span of the arch is 10 ft. and its rise 8½ ft. The feet of the arch are set on stilts which allow a subsidence of 18 in. When the face has advanced so that it is 150 ft. ahead of any arch, the stilts are removed and the feet of the girders sink into the floor.

One need not worry, said Mr. Carson, that the bags will decay and let down the packs. He had deliberately ripped the bags 225 to 300 ft. back from the face and found that the outer 2 or 3 in. of filling material was loose, but that the rest was so compact that it would not run of its own accord. He is now using bags for pack building at a face advancing to the dip on a gradient of 1 in. 1½ (33 deg. 41 min.), and after two months' experience they are proving satisfactory.

The ultimate weight must fall on the bags or packs, said David Jeffreys. When cogs were used to assist in the support of the immediate roof (that is, the relatively loose rock over the coal), the cogs and bags, or packs, must contract equally

under load or the weight will fall on one or the other, which support will act as a pier, preventing equal settlement and causing the roof to fracture.

Cleanings from main roads have made the best material for bagging, said G. W. Knoyle, who had used bags for underground support in place of cog wood for about a year. Rubbish at the coal face, consisting of inferior coal and soft rash, also has proved a good bag filling. He uses also the finer rubbish from repairers' roof rippings and fine moist sea sand.

When he first introduced bags he had sought to economize by completely filling them, declared W. T. Woods, but the men wanted less weight to carry, so some of the bags were not well filled. In looking over a roadway supported by bag packs, he noted that the wall was giving way where the bags were well filled and standing well where the men had been negligent in filling the bags. He concluded, therefore, that they should be under rather than overfilled.

R. Dawson Hall

the length of stemming be in no case less than half the length of the charge of explosive and never less than 2 ft. In many instances the hole should be stemmed to the collar. The circular gives many other valuable suggestions on shooting practice and control.

Illinois Mineral Industry in 1934, by W. H. Voskuil and Alma R. Sweeny. State Geological Survey, Urbana, Ill. Report of Investigations No. 39. 57 pp., 7x10 in.; paper.

Coal leads, of course, in Illinois mineral production, the value of coal being about 65.4 per cent of that of all the minerals produced in the State in 1934. Franklin County led, with Christian and Macoupin counties following. The authors show seasonal trends in coal production and employment, distribution of coal in the various cities in the Illinois coal-market area, bituminous coal shipments to ports on lakes Superior and Michigan, and to upper Lake ports, also cargo coal (bituminous and anthracite) shipments to the Chicago district, Milwaukee and Duluth-Superior over some years, the coal production in other States within the Illinois market area, the output of strip-mined coal in Illinois, which has declined from 20.4 per cent of total production in 1932 to 14.1 per cent in 1934, the briquets consumed and a listing of briquetting plants by locations in the Illinois coal-market area, with the average values per net ton in the plant. In the Illinois coal-market area the importation of natural gas increased in 1934, although the rate of growth is declining. In all, the trends of the Illinois coal market are strikingly portrayed.

Some Observations as to Safety Hazards in 47 Northern Colorado Sub-bituminous Coal Mines, by E. H. Denny, U. S. Bureau of Mines. Information Circular No. 6862; 15 pp.

Though the title does not so indicate, this circular contains much of interest as to the character of coal in the northern Colorado sub-bituminous mining district. The sulphur content in these analyses ranges from 0.1 to 3.0 per cent, 63 out of 77 of them being under 1 per cent and many about 0.3 per cent. Moisture percentage as received runs from 15.9 to 42.1 per cent. It is to be regretted that no way has been found to take sulphur out of higher sulphur coal or to coke these amazingly low-sulphur sub-bituminous coals for the manufacture of iron of superlative purity. Ash runs from 4.4 to 13.9 per cent, 33 out of 77 samples having less than 6 per cent. Low-sulphur-percentages in this district appear to go with low ash.

Much has been said as to the lack of safety provisions in some of the mines of this district, especially the smaller ones, and Mr. Denny's notes on specific instances suggest that he was lucky to have made his samplings and inspections without physical injury. Some mines in the district, he said, are so well conducted as not to fall under censure, and the failure of the State department to make proper inspections and enforce appropriate remedies in the small mines is due to lack of sufficient funds, the reason also which makes the small operating companies disposed to take long chances.—R. DAWSON HALL.

On the

ENGINEER'S BOOK SHELF

Requests for U. S. Bureau of Mines publications should be sent to Superintendent of Documents, Government Printing Office, Washington, D. C., accompanied by cash or money order; stamps and personal checks not accepted. Where no price is appended in the notice of a publication of the U. S. Bureau of Mines, application should be directed to that Bureau. Orders for other books and pamphlets reviewed in this department should be addressed to the individual publishers, as shown, whose name and address in each case is in the review notice.

How to Use Permissible Explosives Properly, by D. Harrington and S. P. Howell, U. S. Bureau of Mines, Information Circular 6871; 44 pp.

"Because permissible explosives," say the authors "are used extensively in gassy and dusty mines and generally are the only class of explosive used in very gassy mines and thus are subjected to this hazardous condition of use, one might expect that many, if not most, of the ignitions of gas or dust from explosives would originate from permissible explosives. After diligent search," however, they have "found only thirteen instances of gas and dust ignition caused by or involving permissible explosives. In every one the explosive definitely was known to have been used in a non-permissible manner—it was fired in a dangerous percentage of gas or adjacent to fine inflammable coal dust under one or more additional non-permissible conditions of use. However, the Bureau has detailed records of 65 explosions involving black blasting powder only, 14 dynamite only, 10 black blasting powder and dynamite, and 11 black blasting powder and (or) dynamite with permissible explosives in the United States during the period 1908 to 1932 inclusive."

The authors divide explosives into six classes: (1) ammonium-nitrate explosives (a) with explosive sensitizer,

(b) with non-explosive sensitizer such as resinous matter; (2) hydrated explosives, sometimes low-grade dynamites with salts containing water of crystallization that cool the gases; (3) organic-nitrate explosives, of which nitrostarch is now the only exemplar; (4) nitroglycerin explosives; (5) ammonium-perchlorate explosives; and (6) gelatin explosives where nitroglycerin is gelatinized with nitrocotton.

Emphasis is laid in this circular on preparing the face in a workmanlike manner before shooting, so that crevices which might cause blowouts may be noted and blowouts avoided. Speaking in favor of sheathed explosives, the authors declare "they also would reduce the hazard if used in blasting in chutes in pitching coal beds, where the accompanying hazards do not permit the drilling of holes or the proper confinement of a charge in a hole." In Belgium, they add, "sheathed explosives represent more than 30 per cent of all explosives used to bring down coal."

The Bureau of Mines, they assert, recommends that shots be confined properly with clay or other incombustible stemming; an absolute minimum length of stemming should be required. In this advocacy of clay, this recommendation is at variance with British preferences for sand-clay mixtures with emphasis on sand. It seems essential to safety, the authors add, that

OPERATING IDEAS

From Production, Electrical and Mechanical Men

Second Synchronous Fan Motor Allows Last-Step Discount

When it became necessary last year to install a larger motor to drive the ventilating fan at the No. 4 mine of the Pond Creek Pocahontas Co., opened at Raysal, W. Va., in 1932, a 200-hp. synchronous motor was selected. Its power-factor corrective effect is saving \$80 per month even though the company operates a 600-hp. synchronous motor on the same distribution system—that is, from power purchased for the three mines through a central metering point.

When the 600-hp. motor was put into service on the fan at No. 1 mine (*Coal Age*, June, 1935, p. 266), it raised the power factor of the company load to slightly above 99.5 per cent, which figure represents the last step of power-factor discount in the rate schedule. Coincident with the consideration of a new motor for the No. 4 fan, additional induction motor load developed, and the increase would have reduced the power factor to slightly less than 99.5, thus

causing the coal company to lose the last step of discount and adding \$80 per month to the power bill.

As a result of replacing the original 75-hp. induction motor with the 200-hp. synchronous motor the average monthly power factor was maintained at or raised to 99.7 in spite of other load changes which had a counter effect. Thus the coal company continues to maintain a power factor which enables it to get "the last squeal" of discount on power bills.

Originally the fan was equipped with a countershaft as a means of obtaining low speed and providing a drive connection to a spare motor. This same countershaft is used in the new drive and the 75-hp. motor was moved to a position in line with a pulley mounted on the end of the countershaft beyond the bearing. The pulley ratios are arranged so that this 75-hp. motor can drive the fan at reduced speed in an emergency and the necessary V-belts to complete the connection are kept hanging on the wall near by.

Ratings of the synchronous motor, which was made by the Allis-Chalmers

Mfg. Co., are: 200 hp.; 149 kw.; power factor, 80; 60 cycles; 720 r.p.m.; 2,200 volts; 58.2 amp.; excitation, 125 volts and 25 amp. maximum. A test with the present fan load and a field adjustment of 25 amp. gave the following: input, 99 kw.; line voltage, 2,480; line amperes, 37.6; 161.3 kva.; power factor, 61.4 leading; reactive kilovolt-amperes, 127.2.

A General Electric full-voltage semi-magnetic controller which automatically applies the field after the proper motor speed has been reached was purchased for the 200-hp. motor. Full-automatic action is unnecessary because the fan is adjacent to the lamp house, which is never without an attendant.

Glittering Calls Attention To New Annual Safety Signs

To attain the variety that is necessary to attract the human eye, the 1936 record and slogan signs selected by the Wheeling Township Coal Mining Co., Adena, Ohio, are of a type on which the letters glisten and change appearance with each changed angle of view or source of illumination. The accompanying illustration is from a photograph of a pair of the signs as mounted on a door in the mine. Fifty pairs of the signs have been tacked on bulletin boards and at other prominent places in and about the mining operation.

The glistening and variation of the letter brightness is indicated in the illustration, but the effect defeated clear photography in the narrow heading where the floodlight could not be placed at the most advantageous angle. The left-hand sign reads as follows: "Slogan for 1936, 15 per cent reduction in accidents and no fatalities—It can be done and with your help it will be done." The other sign, headed "Our Safety Record" and concluding "It's Up to You," sets forth the record, and a question for 1936, as follows:

Year	Accidents	Tons per Accident
1929	144	3,704
1930	122	4,135
1931	80	6,140
1932	40	11,080
1933	34	14,885
1934	27	20,437
1935	23	34,513
1936	?	?

The mine produces 3,000 tons per day from the Pittsburgh No. 8 seam and the

The original induction motor displaced by the larger synchronous motor appears at the extreme right hand. Its pulley, which is hid by the overhung exciter, is lined up with the spare pulley on the countershaft

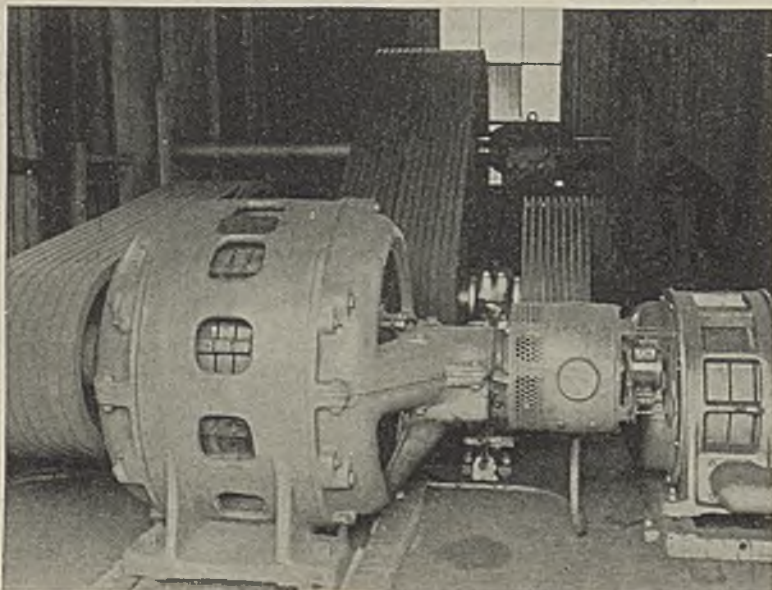

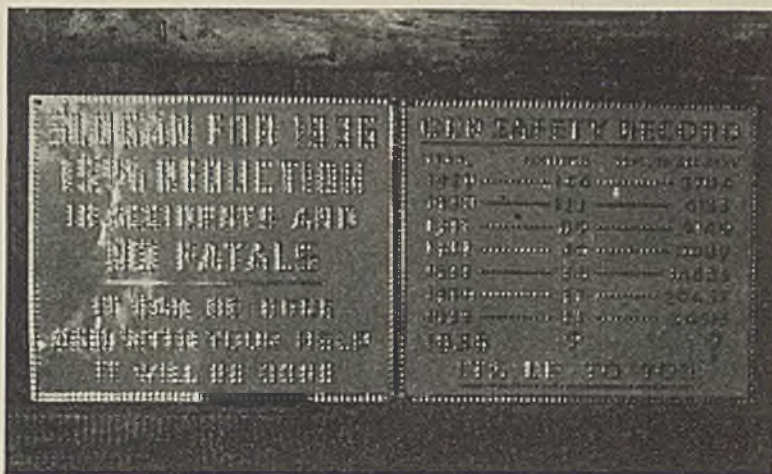

Glittering letters call attention to the sign

coal thickness is 56 in. For nine years the operation has been full-mechanical and nine Joy Type 5BU machines load the entire production.

The signs, made by the Duro Products Mfg. Co., Canton, Ohio, are made from polished No. 30 gage aluminum sheet. The letters and border, both unpainted, are stamped to a raised position and are knurled instead of smooth. The body or background of the sign is painted yellow.

Thousand-Dollar Compressors Displace Obsolete Units

Of four new portable air compressors which cost approximately \$1,000 each and are used in mines of the Lillybrook Coal Co., Lillybrook, W. Va., one has been in service over a year and the others for several months, yet none has given any mechanical trouble. Old-type horizontal water-cooled compressors which stood too high above the rail for efficient use under present mining conditions and which were extremely expensive to operate and maintain have been discarded in favor of this new air-cooled compressor which is suitable to low coal and is not subject to freezing and burst-

ing in winter time when brought outside or near the portal of a drift opening.

The new portable compressor consists of a mine-shop assembly of an Ingersoll-Rand 68-cu.ft. Type 30 stationary compressor, Westinghouse 15-hp. 250-volt Type SK motor, Ohio Brass Type DRT automatic starter, Trumbull safety switch and 10-cu.ft. receiver, all mounted on a truck fabricated by electric welding at the mine shop. The portable unit stands only 33 in. above the rail, although the compressor is 27 in. high.

Over-all length of the truck is 12 ft. and the wheelbase is 40 in., which dimensions are the same as those of the mine cars. The track gage is 44 in. Side frames are 12-in. channels and the bottom of the truck is a ½-in. plate. Straight axles are used and these are positioned several inches above the bottom plate and are without hoods. One axle is between the motor and compressor and the other between the compressor and receiver. A 14-in. clear space between the motor base and bumper constitutes a cab for riding or for carrying tools.

The compressor proper, complete with Winslow down-draft air filter and Dayton ¾-in. double-V-belt drive, cost approximately \$500. The three-cylinder two-stage design with air-fin-pipe inter-

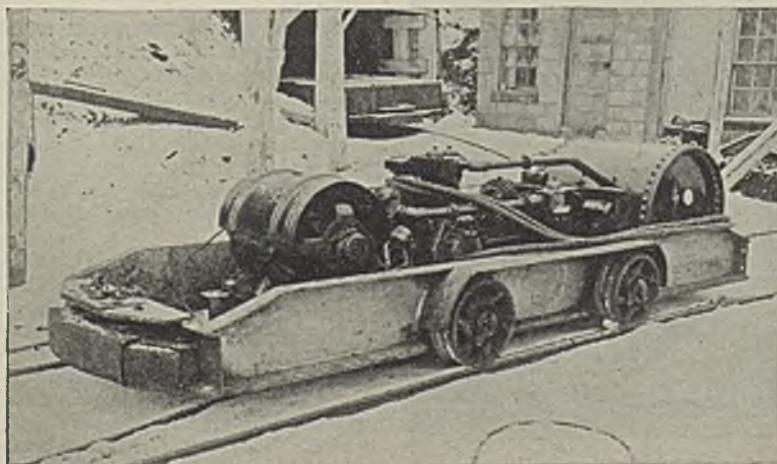

Only 33 in. high and no cooling water to evaporate or freeze

★ Over the Hill

VISITING is perhaps the best method of exchanging information on new ideas in coal mining. If the other operation is just over the hill, such get-togethers are easy. It is when the mine is in another State or across the continent that personal exchanges of operating information become difficult. Visiting by proxy therefore becomes imperative, which is the function of this department. It aims to give operating, electrical, mechanical and safety men the benefit of experience at other operations throughout the country, and to do this solicits their assistance. So, if you have a cost-saving, efficiency-promoting or safety kink, send it in, with a sketch or photograph if it will help to make it clearer. For each acceptable item, *Coal Age* will pay \$5 or more.



cooler and flywheel fan lends a compactness which is especially desirable for the duty. Two 5x5-in. angle cylinders are the first stage and a 4x4-in. vertical cylinder is the second. Cylinders

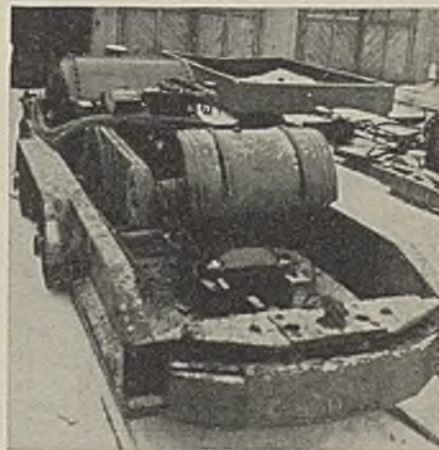

The through-axle, which is a few inches above the truck bottom, appears below the V-belt drive

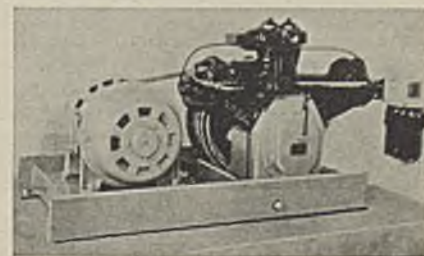

The Type 30 compressor as normally mounted for stationary service

are fitted with unloaders which act when the motor is being started and when receiver pressure reaches 100 lb.

Compressor lubrication is provided by automobile cylinder oil in the crankcase and the shop mechanics change this oil at regular intervals. The receiver, which is fitted with pressure gage and safety valve, has an outside diameter of 27 in. and is 36 in. long.

Capacity of this portable compressor has proved ample to operate one jack-hammer for the general rock work of taking top or bottom to gain height on haulways. J. W. Ailstock, general superintendent of the Lillybrook mines, conceived the idea of adapting this Type 30 compressor to portable mine duty and is responsible for the general design of the truck and assembly.

Working Hints From a Shopman's Notebook; Jigs for Holding Motor End Plates

By **WALTER BAUM**
Master Mechanic, Perry Coal Co.
O'Fallon, Ill.

WITH no spares immediately available, building up of broken or worn end plates for G.E. HM-822 locomotive motors by either bronze or electric welding has been found advisable at our operations to eliminate the delay that otherwise would ensue while new ones were ordered. As it is impossible to hold this type of armature end plate with a lathe chuck, turning the plate after building it up required the development of a jig for holding it in the lathe. The end plate to be held had a machined outer diameter of 13 in., with a flange on each side.

The first step in making the jig was to mark the center of an 18x18x $\frac{1}{2}$ -in. steel plate with a center punch. Two circles, one 12 $\frac{1}{2}$ in. and the other 18 in., were then scribed on the plate and a line was drawn

removed and laid flat on a bench and the ring placed upon it with the inside circle matching the 12 $\frac{1}{2}$ -in. circle on the faceplate. With the line in the center of the two notches on each side of the ring in the centers of two of the T-slots on the faceplate, the other six slots (one T-slot and two open slots which do not extend to the outside edge of the faceplate on each side of the center line) were outlined with a scrawl. After marking, the ring was turned over and centers were marked so that $\frac{3}{8}$ -in. holes would come at the tops of the open slots. The two T-slots were center-punched to match the distance from the outside edge of the ring. Drilling the six $\frac{3}{8}$ -in. holes and four additional $\frac{3}{8}$ -in. holes equally spaced around the ring and about 1 in. inside the inner diameter was the next step. Six pieces of $\frac{1}{2}$ -in. pipe just long enough to keep the cone-shaped end of the end plate from touching the faceplate were then placed over the six $\frac{3}{8}$ -in. holes and brazed to the ring on the side that had been scribed. The lines between the notches were then cut out with a torch to within $\frac{1}{4}$ in. of the inner diameter of the ring.

Upon completion of the above opera-

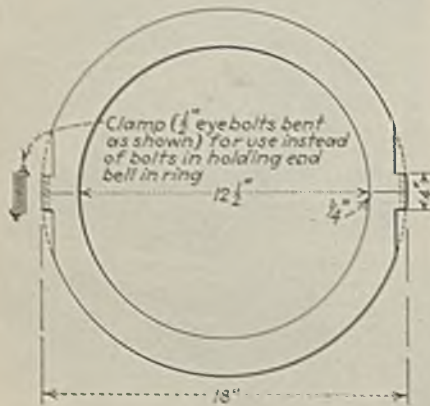

Fig. 1—Clamping ring used in jig for holding HM-822 motor end plate

If $\frac{1}{2}$ -in. plate is used for ring, it will be necessary to build up the portions between the notches where the $\frac{3}{8}$ - or $\frac{1}{2}$ -in. holes for the clamping bolts are to be drilled or use the eye-bolt clamp shown in the figure.

through the center of the circles, after which the plate was cut along the circles with a torch, leaving the ring shown in Fig. 1. Four notches were then marked on the ring as in Fig. 1 and cut out with a torch.

The next step was to place a large faceplate on the lathe and, with the lathe in motion, inscribe a 12 $\frac{1}{2}$ -in. circle on it with crayon. Afterward, the face plate was

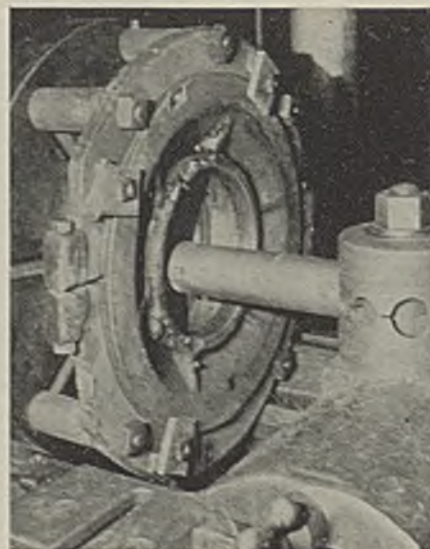

Fig. 2—Jig with end plate in place on lathe for machining

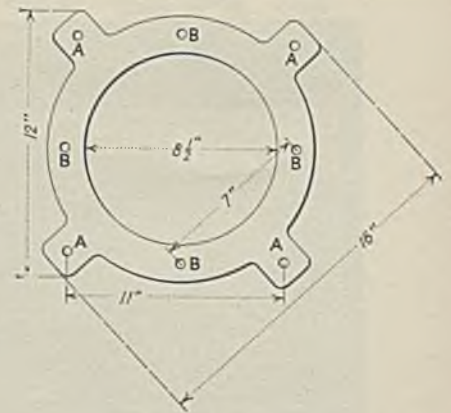

Fig. 3—Details of jig for Baldor motor end plates

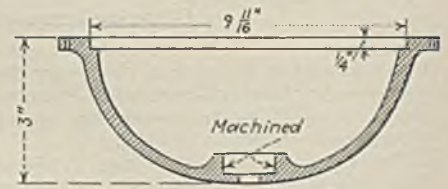

Fig. 4—Cross-section of Baldor end plate showing part to be machined

tions, the ring was bolted to the faceplate, which had been placed back on the lathe, care being taken to get the inside circle as true as possible. The ring was trued on the face just enough to give the flange on the end plate a good bearing surface, and the inside diameter was bored out to the same size as the machined bearing surface on the end plate. The latter operation left the ring in two halves. One half was removed from the faceplate and the motor end plate was placed in the remaining half and the half that had been removed was replaced. Using the two bolts (Fig. 2) or clamps (Fig. 1) to draw the two halves of the ring together, the $\frac{3}{8}$ -in. bolts were replaced in the half that had been removed, and the flanged part of the end plate was drawn up tightly against the machined surface of the ring by four small plates and $\frac{1}{8}$ -in. bolts. After all the bolts were tightened, it was only necessary to true up the parts of the end plate that had been built up.

After the jig had been used for the one end plate it was removed from the faceplate and the inside diameter built up by electric welding to permit remachining for use again on the same-sized end plate. It is impossible to put the jig back on the faceplate and get it true after it has been removed, although the jig can be used on a larger end plate without building up the inside diameter.

In machining bearing retainers in the end plates of 5-hp. Baldor 52 M.A.C. ball-bearing motors after building them up by bronze welding when worn, a somewhat different type of jig was developed for holding the end plates true on the lathe. The jig was made from a ring cut from a $\frac{3}{8}$ -in. steel plate. As the only spare piece of plate handy at the time had a diameter of only 12 in., the four ears were welded on so that there was sufficient distance be-

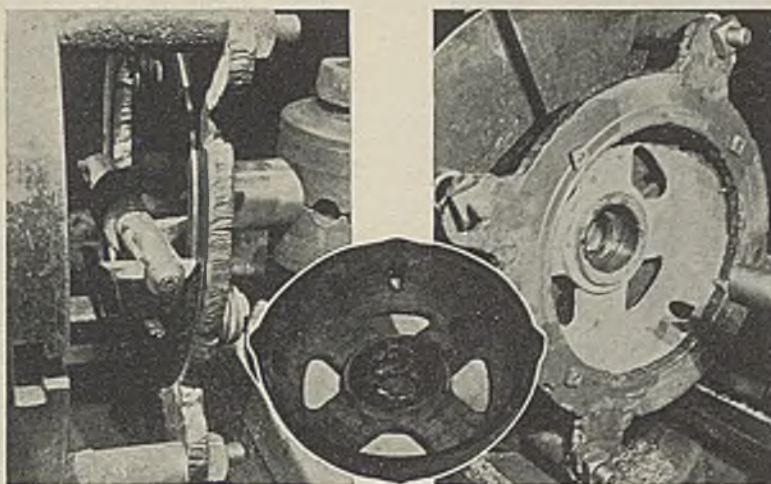

Fig. 5 (Left)—Machining inside surface of ring to accommodate end plate; Fig. 6 (Center)—Baldor motor end plate built up for machining; Fig. 7 (Right)—Jig and end plate in place on lathe for machining.

tween the bolts holding the ring on the faceplate to allow the end plate to be slipped in between them, as the end plate had to be held from the back side of the ring.

In laying out the jig, the large faceplate was used. After putting it on the spindle a circle 8½ in. in diameter was marked on it with crayon. The ring (Fig. 3) with an internal diameter of 8½ in., was then laid against the faceplate with the four ears over common slots in the faceplate. Holes in the four ears were marked to give a distance of 11 in. from center to center of holes, which were drilled. The ring was then bolted to the faceplate by ½-in. bolts, using spacers of 1-in. pipe 3½ in. long and aligning the inner circle of the ring with the circle on the faceplate. A circle 10 in. in diameter was marked on the face of the ring (Fig. 7) with a lathe tool. Center punch marks were made at four equidistant points on this circle. The ring was then removed from the faceplate and 13/32-in.

holes, later drilled and tapped for ¼-in. No. 13 USS threads, were drilled at the punch marks.

Next, the ring was put back on the faceplate and trued up, using the 10-in. circle made by the lathe tool. One-half-inch bolts were screwed in the tapped holes (Fig. 5) so that they were just flush with the inner surface of the ring. This was done to prevent jumping of the lathe tool in turning the back of the ring just deep enough to allow the machined surface of the motor end plate to fit snugly. The bolts were removed after machining and the holes were employed to clamp the end plate to the ring, using ½-in. bolts. The end plate was then ready for machining out the built-up surface to the proper size for the bearing. If the machining has been carefully done the other end plate will fit the shoulder and be held true. After removing the jig the machined surface must be built up by electric or bronze welding and remachined before being used again.



Method of attaching hold-down to trough

by removing the two bolts which hold the two parts of the arms together. Holes in the upper ends of the arms allow them to be fastened in holding units made of two short pieces of angles bolted to a 3x8 or 4x8 timber. To in-



Hold-down installed on a conveyor at Peerless No. 3 mine

stall the hold-down, the timber carrying the angles is placed on top of two posts and wedged in place against the roof, after which the two arms, adjusted to the proper length, are slipped over the ends of the horizontal member under the trough. The arms, being rigid, hold the conveyor down to the proper working position.

Plug Prevents Derailments

Where there is a possibility of cars in heavy trips cutting in on the wrong track, the "plug" shown in the accompanying illustration has been found useful by the Loup Creek Colliery Co., Page, W. Va. This plug, developed by Mason Smith, master mechanic, consists of a piece of square iron bent to fit the wing of the frog and the opening at the point. The plug is held in place by a bolt which also acts as a hinge and thus permits it to be thrown back out of the way when it is desired to use the other track. Practically complete elimination of derailments at



Plug in place in a frog

frogs around tipples and in similar locations has been the experience of the company, which has employed the device for several years.

Shaker-Conveyor Hold-Down Quickly Installed

For holding down shaker conveyors where necessary, the device shown in the accompanying illustrations has been developed by Jack Jones, superintendent, and Harry Draper, mechanic, No. 3 mine, Peerless Sales Co., Peerless, Utah. Principal objectives in the design were ease of installation and adjustment. The unit consists of a flat bar to which a plate cut out to the shape of the conveyor trough is bolted. Two holes in the plate permit it to be attached to the conveyor by the trough connection bolts. The ends of the bar are rounded to fit in holes in the vertical arms, which are made of two pieces of bar steel drilled with a series of holes to permit them to be lengthened or shortened as desired

Wood-Mounted Connectors Serve Conveyor Cables

Strength and low cost were achieved in the design of cable-plug terminals for use with conveyor mining equipment of the Kellys Creek Colliery Co., Ward, W. Va. These terminals, which were built in the mine shop, incorporate standard and inexpensive plug-type connectors purchased from a mining-machine manufacturer. The female part of the connector (see illustration) is clamped between two pieces of 2x4 each 12 in. long. The two pieces are spiked together and the same spikes fasten the 2x4's to the 2x10x18-in. base. The wood is oak. Pieces cut from used belting and nailed to the ends of the lower 2x4 serve as handles.

These terminal blocks are used at the face end of the room cable, to which they are permanently attached. Normally the cable connection supplying the face-conveyor motor is plugged into the

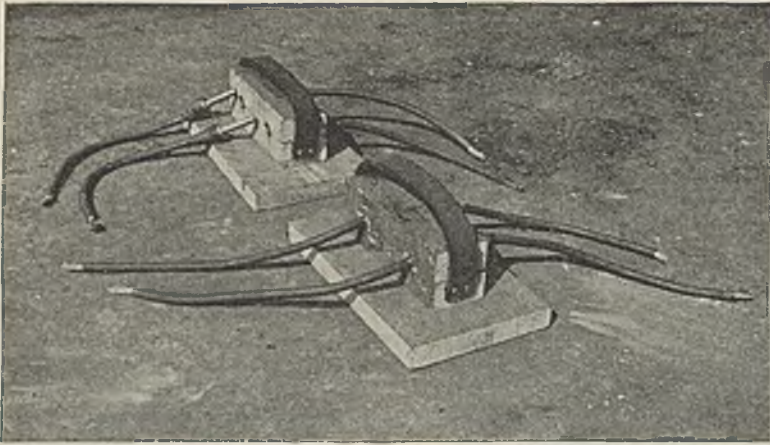

One terminal is shown with the connector plugs pulled out and the other with them in place. The room cables will be spliced onto the right-hand leads, which are soldered to the female connectors embedded in the block

terminal. When the working place is to be undercut, the conveyor plugs are withdrawn and the mining-machine plugs inserted. If the method of working were to be changed, thus making it necessary to operate both the mining machine and the face conveyor at one time, the terminals would be rebuilt to contain two pairs of the female connectors. Cost of the terminals, including connectors, was less than \$1.25 each.

Plow Spreads Larry Discharge

For moving refuse discharged from side-dumping larries over the side of the fill, Walter Iman, Kitzmiller, Md., suggests the plow shown in the accompanying sketch. With this plow, mounted on the larry just back of the door, it is possible, says Mr. Iman, to dump two to three times the quantity of rock at one moving of the track and at the same time make a better road. The plow itself consists of a piece of heavy sheet iron bolted to a piece of 30-lb. rail bent to the shape shown in the illustration. The ends are flattened and drilled for the hinge bolts. Hinges are made of $\frac{3}{4}$ -in. flat steel and are bolted to the side of the larry through holes left by cutting out the rivets. A chain fastened to a hook on the side of the larry holds the plow in working position and also serves to hook the plow up against the side of the larry and out of the way when not in use. In operation, the

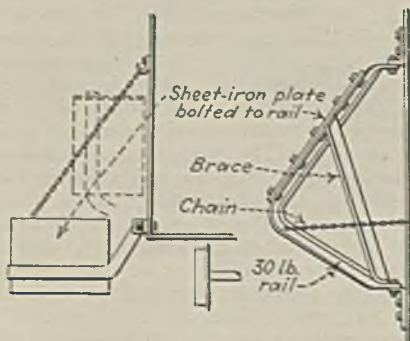

Diagrammatic sketch of plow for installation on side-dump larry

larry load is dumped, the plow is dropped down into position and the larry is moved ahead, thus pushing the rock away from the track and down over the side of the fill.

Counting Operations by Causes Speeds Relay Adjusting

Proper adjustment of relays with due regard for practical operating limitations requires a record of performance. Where any one of two or more relays may be responsible for opening a circuit, as is the case with the automatic breakers in substations at the Powellton (W. Va.) mines of the Elkhorn Piney Coal Mining Co., it is desirable to know the number and percentage of breaker openings chargeable to a certain relay or cause.

Accordingly, W. C. Porter, electrical engineer of the Powellton division, has worked out a method of applying a counter to keep a separate record of the number of d.c. breaker openings due to operation of the Westinghouse Type



The lever added to the Type 00 relay operates the counter mounted below it

BA thermal overload relay which was added as an improvement to the original manual control.

In the accompanying diagram, the Type 00 relay (Electric Controller & Mfg. Co.) was added as the actuating

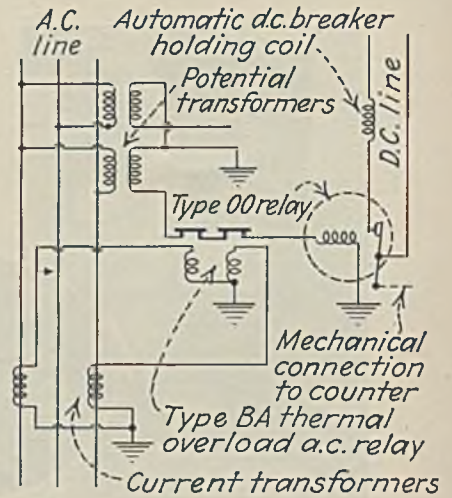

Automatic breaker openings due to sustained a.c. overload are counted separately

agent for opening the holding-coil circuit of the automatic breaker and to operate the lever of the Veeder counter. This relay, having a 110-volt coil and operating with the contact normally closed, is powered from one of the instrument potential transformers and its power circuit is connected through the thermal relay contacts. The photograph on the back of the control panel shows how a lever to operate the counter was attached to the relay armature by means of a capscrew and slotted-hole arrangement which provides for proper adjustment.

Automatic Signal Warns Against Cars

To warn workmen of the approach of cars, John E. Hyler, Peoria, Pa., suggests the use of an arm extending out over the track and linked with an air valve and whistle to give warning when the arm is struck by the moving cars and deflected. The arm normally is held in extended position by springs, and various types of rod linkages, depending upon the conditions encountered, may be employed to operate the valve and supply air to the whistle.

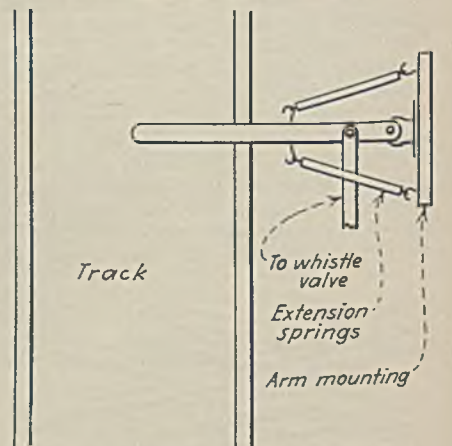

Suggested method of installing arm for operating air whistle

WORD FROM THE FIELD



TVA Attacked in Two Courts By 19 Companies

A joint attack on the constitutionality of the Tennessee Valley Authority was launched on May 29 by nineteen public utility companies which filed actions simultaneously in the Federal District Court at Birmingham, Ala., and in the Chancery Court of Tennessee at Knoxville. The suits are identical in important details and Newton D. Baker, former Secretary of War, is counsel in both proceedings, with a separate group of associates in each action. A petition by TVA to transfer the Knoxville suit to federal court was granted June 15 by Chancellor A. E. Mitchell.

In the bills of complaint it is alleged that the TVA act and the operations under it are unconstitutional on the following grounds:

1. They are not authorized by any power delegated to the federal government by the Constitution or any of its amendments.

2. They attempt to extend federal power over matters of interstate commerce and local police power, in contravention of the Ninth and Tenth amendments.

3. The act fails to indicate any adequate legislative standard to guide the administrative officers; on the contrary, it attempts unlawfully to delegate legislative power to the President of the United States and such administrative officers.

4. The act fails to provide for any hearing for persons whose rights will be injured and whose property will be taken by TVA.

5. The act and operations under it seek to fix the rates of utility companies by means of federally subsidized competition, without a hearing and without opportunity for judicial review as to the reasonableness or unreasonableness of the rates, and thereby deny to the utility companies due process of law, in violation of the Fifth Amendment.

Availing that the joint action was filed "to promote the convenient administration of justice" and "to prevent a multiplicity of suits," the companies further allege that execution of the TVA program "will necessarily and inevitably destroy all or a substantial part of the business and property of each of the complainants." Therefore the complainants ask the courts "to adjudge and decree that the TVA Act of 1933, the power program authorized by said act and the power program promulgated by TVA are severally in violation of the Constitution," and to enjoin it from further operation.

Included in the nineteen companies parties to the suits are subsidiaries of the Commonwealth & Southern Corporation, National Power & Light Co., American Gas & Electric Co., Cities Service Co., Associated Gas & Electric Co. and Electric Power & Light Corporation.

A motion to dismiss the power companies' suit was filed by TVA June 18 in the federal court at Birmingham. The motion for dismissal charged that the util-

ities' purpose in filing the suit was to utilize the functions of the court for trying a "broad political controversy."

Coal at Great Lakes Show

Coal producers and related industries will be well represented among those taking part in the Great Lakes Exposition, which will be held in Cleveland, Ohio, from June 27 to Oct. 4. Among the exhibitors are the following: Cleveland Cliffs Iron Co., City Ice & Fuel Co., Hanna Coal Co., Iron Fireman Manufacturing Co., Pocahontas Fuel Corporation, United States Coal Co. and Zone Coal & Supply Co.

Keeping Step With Coal Demand

Bituminous Production

Week Ended:	1936	1935*
	(1,000 Tons)	(1,000 Tons)
May 2.....	6,845	4,993
May 9.....	6,855	5,640
May 16.....	6,758	5,848
May 23.....	6,811	6,372
May 30.....	6,678	6,769
June 6.....	6,545	8,679
June 13.....	6,784	9,256
Total to June 13....	184,291†	176,349†
Month of April.....	30,318	21,970
Month of May.....	28,678	26,849

Anthracite Production

May 2.....	1,433	909
May 9.....	1,155	935
May 16.....	1,001	1,123
May 23.....	923	1,349
May 30.....	1,163	1,240
June 6.....	797	1,387
June 13.....	838	1,450
Total to June 13....	24,942†	25,920†
Month of April.....	4,336	4,806
Month of May.....	4,577	4,919

*Outputs in these columns are for the weeks corresponding to those in 1936, although these weeks do not necessarily end on the same dates.

†Adjusted to make comparable number of working days in the two years.

Bituminous Coal Stocks

	(Thousands of Net Tons)		
	May 1 1936	April 1 1936	May 1 1935
Electric power utilities..	5,613	5,509	6,205
Byproduct ovens.....	3,515	3,431	5,657
Steel and rolling mills...	807	817	1,384
Railroads (Class 1).....	4,674	4,840	6,619
Other industrials*.....	7,211	7,536	9,734
Total.....	21,820	22,133	29,599

Bituminous Coal Consumption

	(Thousands of Net Tons)		
	May 1 1936	April 1 1936	May 1 1935
Electric power utilities..	2,711	2,896	2,409
Byproduct ovens.....	4,993	4,668	3,862
Steel and rolling mills....	1,157	1,091	1,020
Railroads (Class 1).....	6,840	7,392	6,293
Other industrials*.....	9,459	9,754	8,219
Total.....	25,160	25,821	21,803

*Including beehive ovens, coal-gas retorts and cement mills.

Coal Rate Cut as Surcharges Are Extended Six Months

Maximum emergency charges on coal and coke were reduced from 15c to 10c per ton by the Interstate Commerce Commission in an 8 to 3 decision in Ex Parte No. 115 made public June 13 granting temporary continuance of freight surcharges until Dec. 31, 1936. In denying the petition of applicant railroads for indefinite continuance of the emergency charges, which were to have expired on June 30, the Commission pointed out that "the aggregate revenue derived from the emergency charges on bituminous coal seems disproportionately large, especially in the Eastern group, compared to that derived from any other commodities." This industry, it adds, "is shown to be in a depressed condition and to be suffering materially from the competition of other fuels and forms of energy, most of which pay no emergency charges. Production of bituminous coal in recent years has declined materially, although the consumption of fuels in the aggregate has increased. It is shown that a considerable proportion of the emergency charges on bituminous coal accrue to certain carriers least in need of additional revenue." The maximum charge of 10c per ton on coal and coke, said the Commission, shall "apply to lake cargo and tidewater coal in the same manner that the present 15c charge applies thereto."

"Clearly the situation of the railroads has improved somewhat since our decision last year in this proceeding," the Commission observes. "But it is equally true that the difficult situation of the carriers has not by any means been completely cleared up and the need for additional revenues is still acutely present. We are not prepared to accept as correct applicants' estimates of the aggregate amount of net revenue resulting from the charges. The amount estimated by them, approximately \$105,000,000, is but a statistical computation of the dollars actually collected, over and above the basic rates, on the traffic which actually moved, and makes no allowance for traffic that may have been lost as a result of the imposition of the charges. While applicants' witnesses minimize such losses, the evidence discloses a number of specific instances in which the charges have been a contributing, if not the sole, cause of loss of rail tonnage. Having in mind these numerous individual instances, it is not surprising that many of the shippers' witnesses express the view that the emergency charges have hurt rather than helped the railroads.

"In determining the period of the continuance of the charges, consideration has been given to the seasonal character of the movement of lake cargo coal and iron ore and the desirability of avoiding a marked change in the basis of rates on these important commodities during the shipping season."

Dissenting in part, Commissioners Aitchison, Porter and Tate concurred in the majority decision to the extent that the sur-

charges are eliminated in certain commodities and are abated on others. They opposed authorization of continuance of the remaining emergency surcharges, however, for any additional period, long or short. "Many of the industries which support the rail lines," said the dissenters, "are themselves in worse financial condition than the railroad carriers, and any continuance of the surcharges will cripple them as producers of traffic for the rail system, which, with its existing surplus capacity for service, awaits more business. General economic considerations call for reductions and not for a continuance of increased rail freight charges."

Charles F. Hosford, Jr., chairman of the National Bituminous Coal Commission, and Thomas M. Woodward, Consumers' Counsel of the Coal Commission, expressed the hope on June 15 that the decision foreshadowed "a general reduction of coal freight rates to a fair and reasonable level." Their joint statement pointed out that it was the Coal Commission's contention before the I. C. C. that emergency surcharges on bituminous coal imposed an undue burden on consumers of that commodity and on the industry itself, which for years has been the principal freight revenue producer for the railroads.

Dawson Collieries Organized

Six hundred acres of land east of Dawson Springs, Ky., underlain by No. 6 seam coal has been acquired by the Dawson Collieries, recently granted a charter under the laws of Kentucky. With \$100,000 of preferred stock and 3,000 shares of no-par common, the company has these officers: W. J. Borries, president; J. S. Van Winkle, vice-president; J. H. Schneider, secretary-treasurer; and W. A. Borries, general manager.

The land has been prospected with both churn and diamond core drills and construction of a slope to the No. 6 seam is in progress. The company plans the erection of a modern steel tippie and mining plant with an ultimate capacity of 1,000 tons per shift, production to begin in November. The plant will be served by the Illinois Central R. R., the tracks of which now extend through the center of the property. Main offices of the company will be in Louisville and the mine office in Dawson Springs.

Ford Coal Property Sold

Coal operations of the Fordson Coal Co. at Stone, Ky., have been sold to the Eastern Coal Co. The sale, which was rumored to have taken place during the first week in June, was confirmed on June 8 by Edsel Ford, president of the Fordson company. The purchasing company is headed by Lawrence E. Tierney, Jr., whose father was one of the early operators in the Pocahontas field.

The mine will continue to supply coal to the Ford Motor Co., this being part of the consideration in the transaction. It is also reported that L. C. Skæen will be retained as general manager of the property and that superintendents, foremen and other salaried men will not be displaced. The new owner also has an operation at Sharondale, W. Va.

Filibuster Threat Kills Revised Guffey Bill; Sponsor to Press Fight for Regulation

PROPONENTS of coal regulation got another setback when the Guffey-Vinson Bituminous Coal Act of 1936 was killed by a threat of a filibuster by Senator Holt, of West Virginia, in the closing minutes of the 74th Congress on June 20. This puts regulation on the shelf for more than six months at least, as the next Congress will not meet until Jan. 5, 1937. The bill had been favorably reported by the Senate Interstate Commerce Committee by a vote of nine to five on June 15, and on the following day the House passed it by a vote of 161 to 90.

Senator Guffey was bitterly disappointed over the failure of his bill to pass, but said "the fight is just begun. At our convention I shall offer a plank for the platform providing for government control of the soft-coal industry, and I propose to reintroduce my bill on the opening day of the next Congress." The Pennsylvania Senator said the bill undoubtedly would have been passed but for the filibuster.

As passed by the House the measure embodied several amendments, mostly of a minor character, the principal one being in regard to contracts, Sec. 12 of the original bill—invalidated by the Supreme Court—having been restored during consideration by the House Ways and Means Committee. (*Coal Age*, September, 1935, p. 393). Changes by the Senate Interstate Commerce Committee consisted of new phraseology in describing producer and mine-worker members of the Coal Commission; revision of the tax section; exclusion of lignite from the provisions of the measure, and reduction from four years to two the operative effectiveness of the measure. An effort by Representative Huddleston, of Alabama, to except from regulation States which consume more than 80 per cent of the coal mined in such States was voted down, 86 to 63.

Committee Warns of Chaos

In urging passage of the bill, the House Ways and Means Committee, in its report said that, as a result of the Supreme Court's decision in the Carter case, "unless legislation is enacted immediately the soft-coal industry will revert to the chaotic conditions which prompted the passage of the 1935 act." In view of these threatened conditions, said the report, "it appears highly desirable to have legislation even without the labor provisions of the 1935 act." Despite the elimination of the labor provisions, the committee pointed out, "the bill does seek to provide for labor participation in the administration of the bill, first (Sec. 2a) by providing that two members of the Bituminous Coal Commission shall be representative of employees, and second (Sec. 4, Part 1a) by providing that there shall be a representative on each district board of the organization of employees representing the preponderant number of employees in the industry in the district in question. . . .

"The demoralization of the price structure in the industry which prior to the enactment of the 1935 act existed for many years was in large part responsible for the low wages and poor working conditions in

the industry and for the strikes, in many instances accompanied by violence and bloodshed, which resulted therefrom. It is the opinion of the committee that the stabilization of prices which the bill seeks to effect and the resulting guarantee to operators of a fair price for their coal will go a long way toward stabilization of labor conditions in the industry and toward the guarantee to the miners of satisfactory working conditions and a living wage."

A minority report, signed by Representatives Treadway, of Massachusetts; Bacharach, of New Jersey; Crowther and Reed, of New York, and Knutson, of Minnesota, attacked the bill on the ground that it gave "special interests the monopolistic power to fix their own minimum prices which the public will be required to pay."

"This bill, as did the invalidated act, contemplates a 'little NRA' for the bituminous coal industry, with its attendant monopoly-breeding features," the minority stated. "The larger operators will have the controlling hand in the 23 district boards to be set up, and will be able to dictate the policies of the industry. At the same time, by fixing minimum prices based on costs of production in the larger mines, the smaller, high-cost mines will be forced out of business."

The report of the Senate Committee on Interstate Commerce pointed out that demoralization in the bituminous coal industry was recognized by the Supreme Court in the *Appalachian Coals* case as well as in the *Carter* case. No better summary of conditions prevailing in the industry could be found, said the report, than that presented by Justice Cardozo in his dissenting opinion in the latter action.

The National Bituminous Coal Commission, with offices in the Investment Building, Washington, will continue to function. Elimination of its price-fixing duties by the Supreme Court decision in the *Carter* case will enable it to act on behalf of the soft-coal industry before the Interstate Commerce Commission and other government departments in addition to performing its other duties.

Industry Still Widely Divided On Aftermath of Decision

Industry reactions to the Supreme Court opinion invalidating the labor and price-fixing sections of the Bituminous Coal Conservation Act of 1935 continue to be widely divided, but follow the same general pattern revealed in the *Coal Age* telegraphic survey made a few days after the decision was handed down (June, p. 261). The nearest approach to general agreement is in the belief that operations which have not already done so will be compelled to make capital expenditures for equipment to lower production costs. With no brakes on prices, declares one operator voicing this view, mines "must modernize to survive unrestricted competition." Such expenditures over the next few years, remarks another producer, are inevitable because "labor costs are bound to remain high."

Those who predict no violent changes in

COAL WILL OUTLAST OIL THOUSANDS OF YEARS

Coal reserves of the United States should last several thousand years, at the present rate of consumption, according to a statement by W. A. Selvig, U. S. Bureau of Mines, on June 17 at a meeting of the Purchasing Agents' Association in Hamilton, Ontario, Canada. On the other hand, the known oil reserves would last only fifteen years, said Mr. Selvig.

About 1 per cent of the original coal reserves of this country have been consumed, leaving an estimated 3½ trillion tons still unmined and making the United States the repository of about half of the world's supply, Mr. Selvig continued. The larger portion of the reserves consist of low-rank bituminous, sub-bituminous and lignite, while the quantity of unmined coal of higher rank is much smaller.



ducer is tonnage-minded. Just as soon as he feels that he has not received the tonnage to which he is properly entitled, he will take any step he can think of to move the extra coal and this almost invariably will lead to a breaking down of the price structure. Moreover, it is necessary to consider price coordination between different selling agencies. I have been familiar with the difficulties encountered in this connection under the Guffey act and I realize just how complicated and tender a situation this develops."

In discussing the effect of the decision on capital expenditures, a few operators take the position that many companies—particularly the smaller ones—will be unable to make the investments necessary in cost-reducing equipment because of lack of money or borrowing power. Some companies, it is suggested, will adopt a "watchful waiting" policy on expenditures of this character. In some cases, runs an infrequent comment, companies also may hesitate to mechanize underground operations because their managements believe their natural conditions do not favor mechanization. But, counters a spokesman for the majority opinion, "all forward-looking coal producers realize that it is necessary to mechanize in order to keep costs down to a basis that will enable them to compete with stripping operations and with deep mines that are already mechanized."

Safety Winners Announced

Ingram Branch mine of the Elkhorn Piney Coal Mining Co., in Fayette County, West Virginia, was the winner of the "Sentinels of Safety" trophy in the bituminous-coal mine group for its safety record in 1935. The mine worked 235,211 man-hours without a disabling accident. The winners were announced on June 16 by Dr. John W. Finch, director of the U. S. Bureau of Mines, which sponsored the National Safety Competition, the trophies being presented by the *Explosives Engineer* magazine.

In the anthracite mining group, the winner was Jeddo No. 7 mine of the Jeddo-Highland Coal Co. This mine was operated for 184,992 man-hours in 1935 with

only six lost-time accidents causing 66 days of disability.

Honorable mention in the bituminous industry was given to the following: Thacker and Vulcan mines, Norfolk & Western Ry., Pike County, Kentucky; No. 5 mine, Lost Run Coal Co., Pomeroy, Ohio; "C" mine, Union Pacific Coal Co., Superior, Wyo.

In the anthracite group, the following operations received honorable mention: Stillwater, Miles Slope and Clinton mines, Hudson Coal Co., and Highland No. 6 mine, Jeddo-Highland Coal Co.

Anthracite Pact Ratified

The new two-year wage contract covering the anthracite industry, agreed upon on May 8 at New York (*Coal Age*, June, p. 267), was ratified on June 20 at Hazleton, Pa., after a three-day ratification convention. These officers of the United Mine Workers signed for the miners: Thomas Kennedy, international secretary-treasurer; Michael Kosik, president, District 1, and Martin F. Brennan, president, District 9, John L. Lewis, international president; Philip Murray, vice-president, and Hugh V. Brown, president, District 7, who were unavoidably absent, will sign later. For the operators the signers were W. W. Inglis, president, Glen Alden Coal Co.; J. B. Warriner, president, Lehigh Navigation Coal Co.; Michael Gallagher, president, Pittston Co.; James Prendergast, president, Susquehanna Collieries Co.; A. B. Jessup, president, Jeddo-Highland Coal Co.; Ralph Taggart, president, Philadelphia & Reading Coal & Iron Co., and James H. Pierce, president, East Bear Ridge Collieries Co.

New Preparation Facilities

CHANNEL COAL Co., Auburn, Pa.: contract closed with Deister Concentrator Co. for Deister-Overstrom "Diagonal-Deck" coal-washing-table equipment to handle approximately 8 tons of No. 4 buckwheat per hour.

CONSOLIDATION COAL Co., Mine No. 155, Van Lear, Ky.: contract closed with Fairmont Machinery Co. for rescreening plant to make three sizes of coal; equipment will consist of conveyors, vibrator screens, loading booms, surge bins and three large storage bins; smaller sizes will be dedusted and can be remixed in varying proportions; capacity, 280 tons per hour.

NEW RIVER & POCAHONTAS CONSOLIDATED COAL Co., No. 4 mine, Minden, W. Va.: contract closed with Fairmont Machinery Co. for rescreening plant, with equipment consisting of conveyors, vibrator screens, remixing facilities and large storage bins; capacity, 300 tons per hour.

KINGSTON-POCAHONTAS COAL Co., Hemp-hill, W. Va.: contract closed with Wilmot Engineering Co. for 36-in. hydro-separator to wash 2½x1½-in. stove coal; capacity, 50 tons per hour; completed June 10.

KOPPERS COAL Co., Helen Mine, Helen, W. Va.: contract closed with Koppers-Rheolaveur Co. for 8-ft. Menzies cone separator to clean stove, nut and pea, replacing two Menzies hydro-separators; capacity, 100 tons per hour; to be in operation July 15.

LEHIGH VALLEY COAL Co., Prospect colliery, Wilkes-Barre, Pa.: contract closed with Wilmot Engineering Co. for four 48-

price levels ground their opinion on the belief that quotations already have reached bottom and, in many cases, have sunk 20 to 25c. per ton below production cost. If there is a temporary weakening, says one Eastern producer, the decline will be of short duration because there is nothing in the court decision "to enable various coal companies to reduce costs." Whatever incentive there was to reduce these prices, states another large operator, has been spent; considerable tonnage was sold at low figures prior to the decision in anticipation that the act might be upheld and that such sales would build good will. This incentive has been removed and producers now will be "unwilling to give away much more coal."

This cheerful view, however, is challenged by other operators, who point out that since the decision large mine-run contracts have been closed as much as 25c. under last year's figures and some low-volatile slack has sold at 50c. or more under the 1935 level. "Many consumers," asserts another producer, "are asking for lower prices and practically threaten to place business elsewhere if we cannot meet their figure." In the opinion of executives conversant with local conditions, less change probably can be expected in Illinois and Indiana than in any other major producing area—primarily because those States were able to establish a more stable price structure long before NRA and the National Bituminous Coal Commission appeared on the scene.

Price Collapse May Hit Wages

While the majority opinion still holds that no labor disturbances of major importance are on the immediate horizon, many operators frankly fear that a weakening of the price structure will lead to attempts to chisel on wage rates in districts where organized labor is least strongly entrenched. Small mines, observes one producer operating in both the Northern and Southern fields, usually follow this policy during periods of slack demand "and I do not believe it will reach any greater proportions than might have been expected in the absence of a Supreme Court decision." Unless cut-throat competition can be prevented, however, warns another major producer, "labor relations will become increasingly strained during the rest of 1936, with the strong probability that in the more isolated districts in the South mines will go on a non-union basis. This may well result in the spread of trouble throughout the entire coal fields."

Although the decision has given new impetus to the district sales agency movement, a note of regretful skepticism as to whether these organizations can be counted upon to effect a permanent stabilization of the industry recurs in many of the private comments of coal-company executives. "Since these agencies are merely for the purpose of maintaining prices," says one of this dissident group, "we are faced with the problem that they must have such complete coverage in their own individual fields that price cutting by outsiders will cease to be a factor. Unless the agency attitude of the producers has changed considerably in the last few years, it will be almost impossible to attain this coverage and to maintain prices."

The chief difficulty in an agency of this sort lies in the fact that the average pro-





Frank D. Cain

Overstrom "Diagonal-Deck" coal-washing-table equipment to treat 12 tons of No. 1 buckwheat per hour.

WHEELING TOWNSHIP COAL MINING Co., Adena, Ohio: contract closed with Fairmont Machinery Co. for mine-rock and picking-table-refuse disposal plant equipped with steel trestle, belt conveyor, scraper conveyor, electric hoist and rock larry.

Personal Notes

FRANK D. CAIN has been appointed secretary of the West Kentucky Coal Bureau, with offices in Louisville, effective July 1. He succeeds the late C. E. Reed. Mr. Cain, who was administration member of the west Kentucky Coal Code Authority under NRA, was for a number of years chief engineer for the St. Bernard Mining Co., remaining for several years in the same capacity for the West Kentucky Coal Co. when the latter acquired the St. Bernard properties.



A. C. Callen

in. Wilmot Menzies hydro-separators to wash No. 1 buckwheat; capacity, 50 tons per hour; probable date of completion, July 10.

PITTSBURGH Co., Underwood breaker, Throop, Pa.: contract closed with Koppers-Rheolaveur Co. for two 12-ft. Menzies cone separators to clean stove, nut and pea, replacing jigs; capacity, 150 tons each per hour; probable date of completion, early September.

SOUTHERN COAL & COKE Co., Boothton, Ala.: contract closed with Deister Concentrator Co. for Deister-Overstrom "Diagonal-Deck" coal-washing-table equipment to handle a feed of 7 tons of 3x0-in. material per hour.

SOUTHWESTERN ILLINOIS COAL CORPORATION, Percy, Ill.: contract closed with McNally-Pittsburg Mfg. Corporation for complete tippie and washery employing three McNally-Norton automatic washers for cleaning 6x0-in. coal and classifying into seven sizes, with complete mixing facilities; capacity, 600 tons per hour; to be completed about Dec. 1.

SUPERIOR COAL Co., Mine No. 3, Gillespie, Ill.: contract closed with Link-Belt Co. for three-track tippie designed to handle dry run-of-mine coal at rate of 570 tons per hour over picking tables.

SYCAMORE COAL CORPORATION, Cinderella mine, Cinderella, W. Va.: contract closed with Link-Belt Co. for five-track tippie containing shaking picking tables, scraper-type loading booms with rescreens on ends, mixing conveyors and vibrating screens in addition to the regular run-of-mine screen; five sizes to be prepared at first, with provision for a sixth, if needed; capacity, 300 tons per hour.

VIRGINIA & PITTSBURGH COAL & COKE Co., Morgan mine, Rivesville, W. Va.: contract closed with Fairmont Machinery Co. for preparation plant equipped with dump, weight basket, shaker screens, loading booms, remixing conveyor, vibrator screen and coal crusher; tippie to be arranged to prepare four sizes simultaneously with facilities to prepare all sizes and mixtures necessary to meet market demands; capacity, 250 tons per hour.

WESTON COAL Co., Weston Colliery, Shenandoah, Pa.: contract closed with Deister Concentrator Co. for Deister-

A. C. CALLEN, head of the department of mining and metallurgical engineering at the University of Illinois, Urbana, was elected president of Kiwanis International for 1936-7 on June 24. He has been a Kiwanian since 1921, was governor of the Illinois-eastern Iowa district in 1930, and for the last four years has been a member of the board of trustees of Kiwanis International.

D. D. DODGE, vice-president and general manager of W. J. Rainey, Inc., Uniontown, Pa., has resigned that position to become general superintendent of coal mines for the Woodward Iron Co., operating in Alabama.

HOWARD N. EAVENSON, president, Clover Splint Coal Co., Pittsburgh, Pa., has been elected a member of the executive committee of Bituminous Coal Research, Inc., to fill the vacancy caused by the resignation of Charles G. Berwind, vice-president, Berwind-White Coal Mining Co. Mr. Eavenson succeeded Mr. Berwind as a director of Bituminous Coal Research, Inc., a few months ago.

A. C. FIELDNER, chief engineer, Experiment Stations Division, U. S. Bureau of Mines, has been nominated for president of the American Society for Testing Materials, official notice of election to be given

at the annual meeting, June 30, in Atlantic City, N. J. A graduate of the Ohio State University, Mr. Fieldner became fuels chemist in the U. S. Geological Survey at Pittsburgh, Pa., shortly after graduation. When this work was transferred to the newly created Bureau of Mines in 1910 he was placed in charge of the fuels chemical laboratory, and subsequently of the gas investigations laboratory also. While in charge of the gas mask section during the World War he developed the methods used for testing the efficiency of masks against various gases, and later aided in perfecting gas masks for industrial use. After the war, he became supervising chemist of the Pittsburgh station, and in 1921 was given charge of the station. In 1925 he was appointed chief chemist of the Bureau of Mines and in 1927 was placed in administrative charge of the Bureau's Experiment Stations Division.

MILTON H. FIES, vice-president, DeBardeleben Coal Corporation, received the honorary degree of Doctor of Laws from the University of Alabama at the commencement exercises on May 26. In conferring the degree, George H. Denny, president of the university, said of Mr. Fies: "He is one of the chosen few who can be truly called builders of the State of Alabama."

A. H. GOULD, vice-president, Midland Coal Co., was elected president of the Midwest Coal Traffic Bureau at its annual meeting, held June 5 in Kansas City, Mo. Other officers chosen are: executive vice-president, A. P. RUDOWSKY, vice-president, McAlester Fuel Co.; second vice-president, WILLIAM L. CLEMENS, vice-president, Commercial Fuel Co.; secretary-treasurer, H. J. GOUDELOCK. In addition to the above, the following were named to the executive committee: A. F. McELHENIE, vice-president, Pittsburg & Midway Coal Mining Co.; E. M. DOUTHAT, president, Tebo Coal Co.; W. C. SHANK, president, Reliance Coal Corporation; W. P. BROSS, vice-president, Sinclair Coal Co.

COL. THOMAS S. HAYMOND, general manager, Elk Horn Coal Corporation, was re-elected president of the Big Sandy-Elkhorn Coal Operators' Association at the annual meeting held June 2 at Ashland, Ky. He has been president of the organization since its formation, in 1933. HARRY LAVIERS, vice-president and general manager, South-



A. C. Fieldner

East Coal Co., was chosen vice-president, and SIDNEY B. HOSMER, president, Elkhorn Collieries Corporation, was reelected treasurer. HARRY S. HOMAN is secretary.

ROY D. JOSEPH, of Johnstown, Pa., has been appointed by Governor Earle to the post of State mine inspector in charge of the Fourth bituminous district, where he succeeds William Langan, of DuBois, who recently resigned.

W. E. E. KOEPLER, secretary, Pocahontas Operators' Association, was reelected first vice-president of the Smoke Prevention Association of the United States at the organization's annual convention, held in Atlanta, Ga., during the first week in June.

W. B. LEWIS, former traffic manager for the Sloss-Sheffield Steel & Iron Co., has been appointed manager of the newly organized traffic division of the Alabama Mining Institute. According to James L. Davidson, secretary of the institute, the division was organized in the interest of efficiency, to coordinate the work of traffic managers of institute members. Formerly rate matters were handled by the institute's traffic and transportation committee, which employed special attorneys and experts; but such matters now will be taken care of by Mr. Lewis.

CHARLES A. McMORRIS, formerly connected with M. A. Hanna & Co., has been appointed an assistant to Herman Griggs, manager of the Ore and Coal Exchange, Cleveland, Ohio.

NELSON MORRIS, mining engineer, Sahara Coal Co., Harrisburg, Ill., has resigned to join the staff of Allen & Garcia Co., Chicago.

ROY RATLIFF has been appointed general superintendent of mines by the Sloss Sheffield Steel & Iron Co., operating in Alabama, effective June 15. He succeeds FRED OSBORNE, who has been made general superintendent in charge of blast furnaces, coking plant and the Mary Lee R.R.

C. E. SIMS, formerly assistant director of research for the American Steel Foundries, Indiana Harbor, Ind., has been appointed research metallurgist at Battelle Memorial Institute, Columbus, Ohio, where he will direct several new research projects that have recently been initiated there.

ALAN J. SMITH was elected president of the South-East Coal Co. on June 1, succeeding his father, A. D. W. SMITH, who has been made chairman of the board. The company has operations in the Big Sandy-Elkhorn field and headquarters in Cincinnati, Ohio.

D. C. SOUTHERLAND has been appointed superintendent of the Porter mine of the Porter Coal Co., at Adamsville, Ala. He succeeds J. W. GRAY, who was forced to retire because of failing health.

T. C. & I. Slope Leased

The old No. 1 slope of the Tennessee Coal, Iron & Railroad Co., at Pratt City, Ala., has been leased to J. H. McHugh and M. Heard, who will operate the property under the name of the Colonial Coal & Coke Co. The slope was opened more than 50 years ago and, when operated by convict labor, was one of the major producers in the Alabama field.

Indiana Debates Trade Value of Fine Sizes; Lubrication and Safety Discussed

CONTRARY VIEWS on the effect of fine sizes on the coal industry, storage and use of lubricants and methods of securing safer operation without decreasing production or increasing costs were the subjects of the 1936 summer meeting of the Indiana Coal Mining Institute, held June 20 at the Hotel McCurdy, Evansville, Ind. Presiding was B. H. Schull, general manager of the Binkley Mining Co., Terre Haute, and president of the institute.

"The unfortunate tendency toward the use of finer coal is one wherein the industry becomes the victim of circumstances and its own folly," declared Max A. Tuttle, combustion engineer, Knox Consolidated Coal Corporation, Indianapolis, who placed the start of the decline of the Indiana industry at the time of the adoption of the shaker screen, displacing the bar screenings previously made. Industrial consumers still would be using and liking these bar screenings "if the coal industry had not talked them out of it."

Until about ten years ago, "the only demand for double-screened coal in sizes below 2 in. was from the Loop district of Chicago and some Western territories where there was a freight-rate differential in favor of the smaller sizes. We were all happy and making money." Then came the stoker, which "we all looked upon . . . as the Moses to lead us to the Promised Land. . . . What has happened? There are slurry banks and dedusted residue piles in Indiana which individually represent more tonnage than all the unit stokers have brought to Indiana from competitive fuels."

After plants had been rebuilt and lots of stoker coal had been made, "the heralded market failed to come over the horizon, and immediately the sales policy was to disturb everybody who was efficiently using raw screenings by confusing their minds about

the possibilities of dedusted screenings. . . . We lost two-thirds of our small industrial business because we taught the small industrials to use sized coal and gave the screenings to their stronger competitors and the central power stations. Starting the cycle all over again by educating the small plants to require the so-called dedusted or double-screened sizes and continuing to give the resultant fines to the same class of consumers as we did 25 to 35 years ago, how long will it be until the coal industry finds itself entirely at the mercy of the utility interests and the super-industrials?"

A certain number of sizes are necessary, said Mr. Tuttle. "Under our present conditions a progressive operator must have twelve to fifteen individual sizes, not counting combinations, to meet the market demands which the seller, not the buyer, has fostered. In order to stay in balance, this will necessitate more extensive selling with higher costs or forced sales of the accumulated sizes," usually to a consumer who is not a prospect for oil or gas and often a competitor of the purchaser of the higher-priced grades. "If we are to recover our ground against competitive fuels and stabilize our industry, should not our trend be toward lower preparation costs and a minimum of 'rejects'? . . . It is my personal opinion that the answer to our problems is a more uniform price of coal in the steam sizes and a minimum of sizes and tipple losses."

Buyer Must Be Satisfied

"A law which has been in effect since the beginning of time, and has never been amended or repealed, is that the buyer demands and receives the best possible product at the lowest cost," declared E. J. Weimer, general manager, Snow Hill Coal Corporation, Terre Haute, in opening the discussion. "The coal operator is the seller. The lowest cost does not necessarily mean the cheapest coal but a coal that yields the most economical cost of plant operation. Industrial-power-plant managers and coal-burning-equipment manufacturers have been very active during the past ten years designing and installing equipment to burn small sizes more efficiently and economically. As a seller, the coal operator's responsibility is to offer a well-prepared and sized coal to assure more economical plant operation. In other words, it has been necessary for the coal operator as a seller to produce a well-cleaned and sized coal as demanded by the buyer. . . ."

"Since the buyer has been able to obtain a carefully cleaned and sized coal, uniform in sizing and quality day after day, to fit his plant, there has been a decided trend toward the use of finer sizes." Increased efficiency of railroad motive power, including an increase of 75 to 100 per cent in gross-ton-miles per train hour and two to four times in mileage between engine changes, is one of the best examples of the effect of good cleaning and sizing. Better sized coals are in part responsible for the low figure of $\frac{3}{4}$ lb. of coal per kilowatt-hour obtained by some utility plants. The domestic stoker is gaining ground rapidly

Coming Meetings

• Southern Wyoming Coal Operators' Association: annual meeting, July 14, Cheyenne, Wyo.

• The New River and Winding Gulf Electrical and Mechanical Institute: annual meeting, July 16, Gold Room, Mountainair Hotel, Mt. Hope, W. Va.

• Greenbrier Smokeless Coal Operators' Association: annual meeting, July 18, Greenbrier Hotel, White Sulphur Springs, W. Va.

• Pocahontas Electrical and Mechanical Institute: Second Annual Industrial Exhibit, Aug. 20-22, Bluefield, W. Va.

• New River Coal Operators' Association: smokeless coal industrial exhibition, Aug. 27-29, Mt. Hope, W. Va.

• International Railway Fuel Association: annual meeting, Sept. 16 and 17, Hotel Sherman, Chicago, Ill.

• National Safety Council: 25th annual safety congress and exposition, Oct. 5-9, Atlantic City, N. J.

and here also the coal operator must furnish a clean and sized coal. "The coal operator as a seller should produce and prepare coals the buyer needs and wants, just as any other merchant selling food, clothing, building material, equipment, etc."

Under present conditions, bar screenings and mine-run are not the right sizes to produce, said John A. Garcia, Allen & Garcia Co., Chicago, who pointed out that with the introduction of the chain-grate stoker a more uniform sizing was a necessity, which naturally led to the introduction of the shaker screen. Loss of slurry or fines in washeries, he contended, is a step in the march of progress and eventually some method of utilization will be found. The industry had the same problem with screenings 30 years ago. The quantity of impurities removed in preparation has increased, but by the same token the operator has no business shipping dirt to a user. Preparation of a larger number of sizes makes it possible to ship to a wider variety of consumers in a greater number of market areas.

In response to an inquiry, one equipment manufacturer suggested, said W. D. Ingle, Ingle Coal Co., Evansville, that fines made as a byproduct in the preparation of other sizes might be utilized in part on the spreader-type stoker; otherwise, they might be mixed with the larger sizes for disposal.

"As the demand increased for machines operating at higher speeds and carrying greater loads, it became necessary to pay more attention to lubricants and lubrication," stated William Hurst, superintendent, Princeton (Ind.) Mining Co., in introducing an analysis of the problems involved in the storage and use of oils and greases, abstracted at greater length on p. 287 of this issue. Maintenance of and the quality of the lubricant while in service, he said, involves both (1) the prevention of the entrance of foreign materials into the system and reduction of deterioration of the oil itself to a minimum and (2) removing deleterious substances as soon as they form in or enter into the lubricating system.

Fit Lubricant to Job

"Care should be taken to use the right lubricant on each job," declared David Ingle, Jr., general superintendent, Buckskin Coal Corporation, Evansville, who pointed out that "over-all operating cost must be the guide in choosing rather than lubricating cost." Dirt in the lubricant may defeat the purpose for which it is intended, and "for this reason and to prevent waste and misuse, oiling and greasing should be confined as far as possible to a trained crew of men. They should have the proper equipment for dispensing the materials without introducing dirt. Wherever possible, lubricants should be stored and dispensed from the original containers. Means should be provided for measuring the quantities used, as this will not only aid in comparing different products but may aid in the detection of troubles developing in the machines before they become serious. Excessive lubricant consumption should be promptly investigated."

"It might be suggested that instead of trying to eliminate the many natural hazards which exist to cause personal injury we perfect man's few physical qualities to the extent required to combat all personal injury hazards," stated D. W. Jones, superintendent, Valier Coal Co., Valier, Ill. However, "if we did not attempt to elim-

inate the hazards and endeavored to train men to combat all which might arise, we would find the training expensive and soon would exhaust our source of supply of men for hazardous work. The logical way to meet the situation is to remove as many of the hazards as possible and thus reduce the liabilities to injury which occur when an emergency arises and the human machine is caught off guard.

Nothing Routine About Safety

"Safety work should not be considered routine. It is the most highly specialized and diplomatic service we have to learn. Usually, when a new safety practice is suggested the first question asked is, 'How much will it reduce production?' and second, 'What will be the increased cost of production?' These questions come naturally, as it is a well-known law of science that every action must have an equivalent and opposite reaction. If we persist in doing things in a dangerous way, personal injury will result eventually and then any saving that might have accumulated by the winnings of chance will be spent to pay off the debt of the injury. The new ideas of a safety program are along sensible lines. It is granted that the man who carries life insurance is living on a more substantial basis than the man who does not. He pays the premium on his policy and feels confident of his protection. Why should not the employers of men in all hazardous work look upon safe conditions as an insurance policy, pay the premium for safety devices and feel confident of the results that will be obtained?"

Safe practices, said Mr. Jones, should be looked upon "as a financial investment bound to pay dividends. It may be necessary to make some capital expenditures, just the same as it is necessary for a man to pay the premium on his life insurance policy, but when we invest in safety devices we buy something just as tangible as a loading machine or a locomotive. When a bond issue is made we prepare a prospectus outlining the arguments for the issue. In making an investment in safety we must do likewise and then conduct a campaign to sell safety ideas, and these ideas must be as capable of paying their way as bonds."

Looking upon safety as an investment, a method of presenting the arguments and facts for the move must be developed. "First, we must have an organization headed by conscientious and dependable salesmen. The supervisory force must be the safety salesmen, and they must be



PERMISSIBLE PLATES ISSUED

Four approvals of permissible equipment were issued by the U. S. Bureau of Mines in May, as follows:

Joy Manufacturing Co.: Type 7-BU loading machine; 35-hp. motor, 500 volts, d.c.; Approval 300A; May 6.

Joy Manufacturing Co.: Type 11-BU loading machine; 50-hp. motor, 250-500 volts, d.c.; Approvals 301 and 301A; May 26.

Mine Safety Appliances Co.: M.S.A. Type W-S methane-indicating detector with Edison Model K permissible electric cap lamp; Approval 305; May 5.

trained for their work by someone who has a thorough knowledge of what price must be paid for continuing unsafe practices." Such instructors and the necessary courses the Bureau of Mines stands ready to supply. "New enterprises cannot be established without capital expenditures for material and equipment. Neither can our safety bonds be sold by our foreman-salesmen unless the safety adventure is built upon a substantial basis. . . . Miners must have protective equipment so that they can face their jobs with confidence of safety. The essential protective equipment for a coal miner is a safety cap, safety shoes and goggles." Caps and goggles are specialized equipment "and should be considered by the company as operating equipment, the same as track material and timber." Shoes, however, are used in other industries "and are properly considered personal wearing apparel."

If protective equipment is to be introduced progressively, the first item should be safety caps, as the head is the most vulnerable part of the body; next, safety shoes; and third, goggles. Application of the latter, however, does not lend itself to mass analysis because of the factors surrounding their design and use. Item 4 in capital expenditures is respirators for such applications and in such types as conditions may warrant. "After the groundwork has been laid for safety by the capital expenditures for equipment it is up to the supervisors to show their salesmanship and get results."

How Safety Equipment Pays

The value of safety equipment investments is shown by possible man-day losses and compensation costs such as: fatality from head injury, 6,000 man-days, \$4,000 (married man in Illinois); loss of foot, 2,400 man-days, \$1,500; great toe or any two other toes, 300 man-days, \$400; one toe, other than great toe, 72 man-days, \$125; both eyes, 6,000 man-days, \$4,000; one eye, 1,800 man-days, \$1,200. However, there is another class of returns received without a capital expenditure, such as setting a timber, necessary anyhow, and preventing a fatality, with a saving of \$4,000; and forbidding tripriders to jump on or off moving trips, with consequent slowing down of haulage and loss of output during the period of training in the new rule, which if it saved one life over a period of years would give the company a credit of 6,000 man-days, equivalent to twelve working days for a mine employing 500 men, or 84,000 tons of output for a mine with a capacity of 7,000 tons per day. "If the savings which inevitably result from safety in operation are reduced to tonnage, every mine can produce less tonnage and make the same return by eliminating expenditures for compensation."

Best results, Mr. Jones stated, can be secured only by enlisting the cooperation and interest of the employe. One excellent way is an award of some article, even though the value is not great, which is the practice at Valier, supplemented by division of employees into groups to make sure that they take an interest in the safety practices of the other fellow, on whose freedom from injuries their own award depends. Similar awards and methods of grouping were employed to compensate for the loss of output that otherwise would have occurred through the institution of safety measures. That

the measures taken at Valier will get results is evidenced by the award of two Joseph A. Holmes certificates of honor to the mine in the past two award periods.

Indorsing the work at Valier, A. U. Miller, associate engineer, U. S. Bureau of Mines, Vincennes, stated that while a real safety campaign necessitated the expenditure of money, the resultant improvement in working conditions would increase efficiency and cut accident cost to a minimum.

Earle Signs Dewatering Bill

A bill appropriating \$700,000 to the State Department of Health to defray the cost of dewatering flooded mines in Lackawanna, Luzerne, Fayette and Westmoreland counties was signed June 16 by Governor Earle of Pennsylvania. Of this sum, \$600,000 is to be used in the Pittston-Duryea area and \$30,000 in pumping flood waters from mines in Jessup. The remainder is for dewatering operations in Fayette and Westmoreland counties. Pumping in the Pittston district began during the second week in June.

Coal Exhibitions Planned

Two coal shows are planned for the latter part of next month in West Virginia. The second annual Pocahontas Industrial Exhibit will be held Aug. 20-22 at Bluefield and the Smokeless Coal Industrial Exhibition will take place Aug. 27-29 at Mt. Hope. The Pocahontas exhibit, held under the auspices of the Pocahontas Electrical and Mechanical Institute, was such an unqualified success last year that this year the scope of exposition has been greatly enlarged, covering a wide range of mining equipment and supplies. S. C. Higgins, in charge of arrangements for the Mt. Hope show, sponsored by the New River Coal Operators' Association, reports that reservations of space have exceeded expectations. In addition to manufacturers, the following have reserved space: U. S. Bureau of Mines, State Department of Agriculture, farm and garden clubs of Fayette and Raleigh counties, Chesapeake & Ohio Ry. and the Chesapeake & Potomac Telephone Co.

Power Economics to Fore

American writers listed on the program of the Third World Power Conference, to be held at Washington, D. C., Sept. 7-12, are a fair indication that the contribution of this country to the discussion of the economics of power—the keystone of the meeting—will be of deep significance. Included in the list are eminent economists, engineers, government power authorities and administrators, and utility executives.

Among the papers listed for presentation are: "Internal Use of Statistics," Dr. E. Dana Durand, U. S. Tariff Commission; "Planning for the Conservation of Natural Resources," U. S. Bureau of Mines; "Conservation of Coal Resources," U. S. Bureau of Mines, and "National Power and Resources Policies," George Seale, New Republic, and Lloyd L. Carlisle, chairman of the board, Niagara Hudson Power Corporation.

Producers, Retailers and Equipment Men Probe Sales Problems at Urbana

COAL preparation, transportation, sale and utilization were the principal topics offered June 9-11 at the 1936 Short Course in Coal Utilization by the department of mining and metallurgical engineering, University of Illinois, at Urbana, Ill. Registration totaled 231 from sixteen States and the District of Columbia. General problems in both the coal and other industries also were included in the program. Stating his conviction that governmental cost can be reduced, Merlin H. Hunter, professor of economics, University of Illinois, sketched the relationship between taxation and buying power and pointed out that an industry, if successful in shifting its tax burden, may possibly hurt its own business by reducing the buying power of its customers.

Discussing the parts played in the coal picture by the producers, railroads, equipment manufacturers and consumers, E. G. Bailey, vice-president, Babcock & Wilcox Co., New York, expressed the opinion that at present there is not a very good basis for cooperation between the various groups. Consumers cooperate with each other best, but they, as a rule, are not competitive. More adequate data on coal consumption is necessary, said Mr. Bailey, who also stated that the coal industry is not keeping up with developments in equipment as it should. Furthermore, research to date is inadequate.

The attitude that there is no possibility of expanding present markets is the greatest bar to progress, declared B. R. Gehring, vice-president, Chicago, Wilmington & Franklin Coal Co., Chicago, in a discussion

of "Coal Sales Beyond the Horizon." While many of the more daring suggestions, such as motor fuel from coal, may become actualities in the future, the coal industry possibly should concentrate on less spectacular gains which will result from an improvement in the quality of industrial coal salesmanship, growth of the stoker in the domestic and commercial fields and extension of research.

All other methods of transporting coal are increasing at the expense of the railroads, said C. V. Beck, president, St. Louis Coal Co., St. Louis, Mo. Waterway transportation, he stated, should show a normal and gradual increase which should not disturb the industry. Appropriation of the short-haul rail business by trucks and the growth of long-distance hauling with this equipment is the most rapidly changing factor in coal transportation and eventually will force a revision of short-haul rail tariffs, although it seems evident that a certain proportion of the business will revert permanently to the truck. Growth of trucking also is bringing about shifts in markets by fostering the use in many consuming centers of local coals, which in many cases are poorer in quality and in turn seem likely to force a revision in combustion equipment and practices in these centers.

Pointing to the need of some system of predicting variations in coal characteristics—ash, sulphur, percentage of fines, etc.—D. R. Mitchell, assistant professor of mining and metallurgical engineering, University of Illinois, stated that for all practical purposes these variations can be determined from a very few analyses. He outlined methods of calculating either "standard deviation" or "probable error" and offered a number of suggestions for preventing segregation of coal in bins and conveyors, and for insuring quick and accurate sampling of coal at mines and plants.

B.T.U. Determination Simple

Determining the heat content of a coal sample is a simple operation, declared A. C. Colten, head of the department of mining and metallurgical engineering, University of Illinois, although requiring the best results a representative sample, good testing equipment and skill in its operation. The words calorimeter gives an "ideal" value for the heat content of the coal being tested, which, of course, is impossible of being realized in service, as many other factors enter into the picture in addition to B.T.U. content. But, on the other hand, B.T.U. value cannot be ignored, as it figures in all applications. Much of the information on B.T.U. values, Prof. Colten felt, is due to lack of understanding of the test and nature of test results. Producers, wholesalers and retailers should cooperate in the proper reporting and use of B.T.U. values as a means of evaluating similar coals.

Preparation and marketing are tied closely together, said Prof. Mitchell in opening a discussion of preparation and utilization of coal as a domestic fuel. No exact information on the effect of size on efficiency is available, although the Babcock Institute, using bituminous No. 10, has found size to be 14 and 20 per cent so efficient. However, the average domestic consumer is getting away from extremely large sizes. More research on the proper

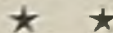

Urbana Timekeepers

Including the informal dinner at which changing trends in heating was the topic of discussion, presided over by John D. Bantz, executive secretary, National Coal Association, the 1936 Short Course in Coal Utilization held seven regular study sessions. The chairmen for the other sessions were:

T. A. Martin, central division engineer, Iron Fireman Manufacturing Co., Chicago—morning session, June 9.

George F. Colton, president, Illinois Fuel Merchants' Association, Rockford, Ill.—afternoon session, June 9.

C. T. Hayden, general manager, Sahara Coal Co., Chicago—morning session, June 10.

W. J. Jenkins, president, Consolidated Coal Co., St. Louis, Mo.—afternoon session, June 10.

Les Glusick, Pulmonia Coal Co., Chicago—morning session, June 11.

William Barstow, Kansas City Coal Service Institute, Kansas City, Mo.—afternoon session, June 11.

A moving picture showing the operations of the Bell & Zoller Coal & Mining Co. was presented at the evening session June 9.



Sinclair Coal Co., Kansas City, Mo., takes attendance honors at the short course. The seventeen representatives of this company, with a few guests, appear in the above group

sizes for hot-water heaters is necessary. In the case of stokers, the top size probably is 1 in., as noise is encountered above this. The percentage of dust or fines should not be too great. Cleanliness is particularly important where the coal is to be used in hand-fired furnaces, kitchen ranges, etc., and therefore is more open to inspection. If sold for stoker use, hard pyrites or other material and tramp iron should be removed. Cleanliness also results in an almost proportional increase in efficiency. Dustless treatment is becoming a more important market factor. Soot and clinker troubles are substantially reduced, as a general rule, if the coal is well prepared, properly sized and clean.

Preparation and utilization of coal in commercial steam plants of not over 150 hp. was discussed by L. A. Shipman, combustion engineer, Southern Coal & Coke Co., Knoxville, Tenn. Interest in the problems of such plants has revived in recent years, Mr. Shipman stated, in introducing an outline of the part of the producer, consumer and, where he enters the picture, the retailer in the preparation and handling cycle. Describing the latest developments in combustion and firing practices and the troubles usually encountered, he called attention to segregation as an important factor in plant difficulties. Recent developments in the multiple sizing of nut-and-slack show that a wide range of sizes in a given grade, rather than fines of themselves, is largely responsible for the troubles encountered. Because of cost, engineering service to individual plants in this class is difficult, but, as the total tonnage consumed by them is large, research is necessary. This can best be carried on cooperatively.

Pointing out that rapid strides have been made in the utilization of the poorer grades of coal, J. G. Worker and C. L. Myers, American Engineering Co., Philadelphia, Pa., in a paper read by the latter, presented an analysis of the characteristics and application of the various types of firing systems for large steam plants. Trouble shooting in high-pressure plants, as distinguished from commercial heating plants and central

stations, was detailed by Osborne Monnett, advisory engineer, Commercial Testing & Engineering Co., Chicago, who stated that a simple rule is to note departures from the normal in any of the plant functions, which naturally presupposes a clear knowledge of what is normal in the plant being examined. Listing many of the common causes of complaints, Mr. Monnett observed that generally the necessary instruments are a draft gage (most important), Orsat apparatus, pyrometer and high-rating thermometer. From the coal standpoint, size may be a greater factor in causing trouble than quality, as a poor coal properly sized may be better than good coal improperly sized.

Problems of railroad fuel utilization revolve largely around combustion losses, declared E. G. Young, research professor of railway mechanical engineering, University of Illinois, in detailing developments in locomotive design for more efficient utilization. As much as 27 per cent of the heat in the coal fired may be lost through the stack in addition to large CO and asphalt losses. Good locomotives at present will consume 70 to 90 lb. of coal per 1,000 gross ton-miles. Eventually, the average probably will be 75 lb. and tests have shown as low as 40 lb. Mines, as a rule, should prepare coal with stoker use in mind for maximum satisfaction. All tramp iron should be removed.

Retailing Problems Analyzed

The problems of retail coal marketing were analyzed in the light of what constitutes a dealer, his operating and merchandising methods, general conditions in the retail market and general conditions in the coal industry as a whole by N. H. Vaughan, assistant general sales agent, Consolidated Coal Co., Chicago. Mr. Vaughan laid particular emphasis on the need for better merchandising on the part of the retailer and also reported the results of a survey of conditions in the retail industry which showed, among other things, that 84 per cent of the dealers covered had an increase in business the past season, but that gross margins were lower in 58 per cent of the

cases, unchanged in 37 per cent, and higher in 5 per cent. Also, 51½ per cent of the dealers regarded the future as favorable, 38 per cent unfavorable, and 10½ per cent expressed no opinion.

Changing trends in heating were discussed by William B. Hughes, manager, automatic coal-burning division, American Radiator Co., New York. Most notable improvements in heating in late years have been the inside air return, automatic humidifier and fans for forced circulation. Now, suddenly, the industry is facing a new era based on automatic heating, air conditioning, etc., growing out of the exceptional value of research work by various agencies, the inventive genius of individuals in developing equipment, a general clarification of the mystery surrounding air conditioning, better production, preparation and distribution of fuel and development of equipment for using it, and a better understanding on the part of the public of the factors involved in plant design and operation. Concluding a discussion of these five points, Mr. Hughes described the design and operation of a modern radiator conditioning system, automatically fired with coal and fulfilling the functions of humidification, air circulation, air cleaning, ventilation, radiator heating, controlled heat distribution and year-round domestic hot water.

Outlining new developments in the household stoker, B. M. Guthrie, chief engineer, stoker division, Fairbanks, Morse & Co., Chicago, declared that these units now are sold more on their ability to deliver automatic heat, with the cost of heating coming in only when oil or gas also is offered. Since 1933, when it became apparent that the stoker would have to be redesigned to take it out of the specialty into the appliance class, improvements have included: better tuyere and retort design, a wide range of units with a corresponding range of capacities, rather than single units with a number of feed capacities; air-volume regulators which meet the varying demands of the fire and maintain a proper fuel bed without manual adjustment; better electrical controls; and better coals. Further automaticity is neces-

sary, and types for 1936-37 include bin-feeding systems, which should not curtail sales of hopper types but instead bring a wider recognition of stoker possibilities by the public. A definite solution of the ash-removal problem, said Mr. Guthrie, is expected in the near future.

Offering a detailed analysis of the process of choosing the proper size of stoker and installing it, Frank J. Hoke, vice-president, Holcomb & Hoke Manufacturing Co., Indianapolis, Ind., remarked that the problem is not too complicated, as present-day stoker design facilitates rather than hinders stoker installation. Proper rating by the manufacturer is a big factor in trouble-free installation, as is proper evaluation of the plant to which the stoker is to be applied. In the absence of any abnormal conditions, Mr. Hoke suggested the grate-area method of determining stoker size. But if abnormal conditions are present, the survey method should be followed.

The hot-water supply was the subject of an address by R. E. Moore, vice-president, Bell & Gossett Co., Chicago, who pointed out that indirect heating offers not only the possibility of equipment sales but also a year-round business in coal. Turning to the heating plant, Mr. Moore discussed the advantages of the circulating pump in hot-water systems, a new development making possible sharp reductions in installation cost and, in many cases, both home and hot-water heating for the same cost as home heating under previous systems.

Operator Sells Stokers

The Pocahontas Fuel Co., said Russell G. Glass, sales manager, stoker division, Cleveland Heights, Ohio, started an investigation of the possibility of furnishing its dealers with equipment that would burn the company's fines in 1929. This study showed both equipment and merchandising policies to be imperfect and service inadequate, and as a result the following principles were established: completely automatic operation, quietness, dustless operation (through dustless treatment of coal and automatic removal of ashes to closed receptacle), smokelessness, maximum economy and reliability. These principles were incorporated in the design of the equipment finally adopted, which was supplemented by the development of a combined sales and service plan placing in one organization all the responsibility for selling, installing, supplying fuel, financing and servicing. A service charge is added to each ton of coal supplied, and little price difficulty has been encountered, as consumers generally are more interested in comfort, cleanliness and convenience. Of the units installed, 71 per cent have replaced gas—in 50 per cent of the cases economy was not the controlling factor in removal of the gas equipment, although 40 to 60 per cent savings have been shown. And in many large Cleveland homes savings of \$12 to \$14 per month have been made in heating water, as compared with gas at a very low rate.

Full automatic heating requires assumption of responsibility for services by some other person than the home owner, declared Paul D. Hess, Heat Service, Inc., Macon, Mo., in detailing the results of the heat-service plan of his organization. The heat-service plan, said Mr. Hess, gives the customer a continuous tonnage, enables the customer to budget his expenditures for heat and results in prompt payment of bills. Over a period of five years, degree-day



The late John Hays Hammond

average has been 85 per cent of the heating season taken as a base, while consumption has averaged 88 per cent of the calculated tonnage. Predetermination of probable consumption, one of the arguments frequently brought up against heat-service plans, offers no particular difficulties said Mr. Hess.

Principles and practices in air conditioning, including air-conditioning standards, physiological processes of heat production by the body, and descriptions and explanations of common commercial types of equipment for various types of service, were presented by M. K. Fahnstock, research assistant professor of mechanical engineering, University of Illinois. He stressed the importance of ventilating air in the efficient functioning of the air-conditioning system.

As compared with other major products, coal is inadequately advertised, declared I. M. Adams, Hubbell Advertising Agency, Inc., Cleveland, Ohio. It is possible to command attention to coal but impossible to create a desire for coal as such. In advertising coal, the initial impulse should come from the producer, who should set an example, furnish a background and make the



STOKER SALES STILL RISING

SALES of mechanical stokers in April last totaled 3,071, of which 2,745 were small residential-size units, according to statistics furnished the U. S. Bureau of the Census by 108 manufacturers. This compares with sales of 2,678 units in the preceding month and 1,282 in April, 1935. Figures for the first four months of this year show that 9,528 units of all types and sizes were sold, compared with 4,356 in the corresponding period a year ago. Sales by classes in the first four months of this year were as follows: residential (under 100 lb. of coal per hour), 9,528; apartment-house and small commercial heating jobs (100 to 200 lb. per hour), 614; general heating and small high-pressure steam plants (200 to 300 lb. per hour), 239; large commercial and high-pressure steam plants (over 300 lb. per hour), 571.

public more tolerant of coal. In this connection, railroads have as much of a duty to advertise coal nationally as the producers, and the same applies to equipment organizations. With this background, the dealer then has the problem of determining the advertising necessary to command his local market and the method of carrying on such advertising.

New Illinois Stripping

Central States Colliers, headed by H. J. Sternberg, operating the Minden Coal Co. stripping at Mindenmines, Mo., is now opening a new strip mine in the No. 5 Fulton County seam, at St. David, Ill. Capacity of the new operation, equipped with a 6-track tippie with a Link-Belt-Simon-Carves washer for the 3x0-in. coal, is 3,000 tons per day. Stripping will be done by a Bucyrus-Erie 550-B electric shovel with 16-cu.yd. dipper; loading by an 85-B shovel with 5-cu.yd. dipper; hauling by four White trucks with 20-ton Austin-Western trail cars. Thickness of the coal is 5 ft.; overburden, 34 ft. average.

Mine equipment will include a power plant with a 2,000-kw. Allis-Chalmers turbo-generator, 500-kw. auxiliary engine-driven generator, B. & W. boilers and Coxe stokers. Power-plant engineering is in charge of C. M. Garland & Co. Walter Bledsoe & Co., Terre Haute, Ind., are sales agents.

Obituary Notes

JOHN HAYS HAMMOND, SR., internationally famous mining engineer, died suddenly of a heart attack June 8 at his home in Gloucester, Mass., aged 81. His long and colorful career in the mining profession extended from the American West in the days of "bad men" to Mexico, South America and the South African gold fields. In the Transvaal he became associated with the Barnato brothers and later Cecil Rhodes, was active in reform activities and ultimately was arrested after the Jameson raid and sentenced to be hanged. He was released, however, by order of President Kruger on condition that he pay a heavy fine. Though his experience had been limited mostly to metal mining, he was chairman of the U. S. Coal Commission established in 1922 to investigate the fuel industry in this country.

WILLIAM H. COOLIDGE, corporation attorney and noted champion of the open shop in the coal industry, died May 28 at his home in Manchester, Mass., at the age of 77. He had been a member of the board of directors of the Island Creek Coal Co. for many years and also was chairman for a time, having retired because of ill health.

ROBERT A. BOWERS, 39, general mine foreman, Panther Coal Co., Roseann, Va., died June 13 at the Mattie Williams Hospital, Richlands, Va., as the result of injuries received in an explosion two days previous.

CLARENCE M. MARTIN, 58, president of the Greenville Coal Co., Greenville, Ky., died June 13 in the Kentucky Baptist Hospital, Louisville, following a heart attack. He had been active for many years in the western Kentucky field.

Servicing Mechanical Loaders, Degradation And Safety Highspot Illinois Program

SAFETY in relation to operating efficiency, car service to mechanical loaders and factors affecting the sizes of coal produced were the themes of the technical sessions at the summer meeting and 18th annual boat trip of the Illinois Mining Institute on board the Str. "Golden Eagle," June 5 to 7. In attendance were 100 members and guests of the institute.

In planning any job, safety should, and often does have today, as much consideration as any other factor, said Charles Fultz, safety inspector, Franklin County Coal Corporation, Herrin, Ill., in opening the morning session on June 6, presided over by John W. Stedelin, president, Marion County Coal Co., Centralia, Ill. Mr. Stedelin was introduced by W. J. Jenkins, president, Consolidated Coal Co., St. Louis, and vice-president of the institute, acting for T. J. Thomas, president of the institute and the Valier Coal Co., Chicago, now abroad. A determined attitude on the part of management will go far toward assuring safe operation, Mr. Fultz declared, but for maximum results the support of the entire organization is necessary. With improvement in safety, operating efficiency likewise will improve.

Trained in Accident Prevention

To enable supervisors to function properly in promoting safety, arrangements were made in October, 1934, for the staff at both mines of the Franklin company to take the accident-prevention course of the U. S. Bureau of Mines. This work was completed in May. To assure safer physical conditions, the motor haulage system was reconditioned. This included loading out 350 railroad cars of gob and 100 mine trucks of old timber and lagging. Grades were reduced, 80 per cent of the main-line track has been laid with 60-lb. rail properly bonded on treated ties, and 75 per cent of the main-line trolley system has been replaced with 6/0 wire. At one mine, mules were used for gathering and handling man trips, but one fatality caused by a mule stumbling resulted in the removal of several animals from service to prevent a recurrence. Standard trapdoors providing ample clearance on both sides of the track now are employed and the practical elimination of coupling on the fly, backpoling and jumping off or onto moving trips has resulted in a material reduction in haulage accidents along with an increase in efficiency.

To promote safety in the working place, the following measures have been adopted: (1) Systematic spragging of the undercut in mechanical-loading and eventually in all territories; (2) replacement of split props with round props—more economical through a substantial reduction in replacements; (3) 75-per-cent use of wedge-shaped cap pieces—eventually 100 per cent—to eliminate hand injuries in using axes; (4) adoption of a standard clearance between track and timbers, with practically complete elimination of injuries from men being squeezed by cars; (5) adoption of systematic sounding of roof by mechanical-loading crews; (6)

abolishment of the practice of crew members working along the face behind the loader; (7) institution of a rule that runners and helpers on cutters must walk in the rear and the front of moving machines to align and realign switches and guard against collisions; (8) prohibition of more than one mechanical unit at the face at one time; (9) adoption of the practice of aligning switches against the place and placing a barricade of ties or timbers across the track to protect cutting and drilling crews. A material reduction in accidents in the working place has followed adoption of these nine measures, Mr. Fultz stated.

As a result of one case of blood poisoning last year, each supervisor now carries a pad of orders for medical treatment, which are issued to men suffering legitimate injuries. That night, the man's lamp is "red-checked," and a release from the doctor is required before it is re-issued. One result has been a material increase in reported injuries; no additional cases of blood poisoning have occurred. Safety hats and shoes are worn by 70 per cent of the employees, with a marked reduction in injuries. Goggles are furnished to main-line motormen, tripriders, timberman and tracklayers. Supplementing the other work, a campaign of cleanliness and orderliness in and around surface buildings has been conducted, with one result: an increase in quantity of work turned out. Dangerous moving machinery is equipped with guards, and car chasers in the yards are equipped with safety belts. A code of standards is now in preparation. These measures, Mr. Fultz stated in conclusion, have not materially increased the cost of production, even though operation is safer and the mines are in better condition.



Bruce G. Shotton

Newly elected chairman of the Manufacturers' Section, Coal Division, American Mining Congress. Because of a printer's error, the caption under the picture on p. 235 of last month's issue of *Coal Age* failed to indicate the office to which Mr. Shotton was elected.

Opening the discussion, A. U. Miller, associate engineer, U. S. Bureau of Mines, Vincennes, Ind., declared that all accidents, whether or not causing injuries, should be analyzed as an avenue to greater safety and efficiency. John Lyons, safety director, Bell & Zoller Coal & Mining Co., Zeigler, Ill., observed that the safety and operating departments must work together for best results. Both must learn from accidents if they are to progress. A major factor in safety work, he declared, is safety standards, which must be lived up to. Comparisons with results at other operations are quite helpful, said H. A. Treadwell, general superintendent, Chicago, Wilmington & Franklin Coal Co., Benton, in urging adoption of standard methods of computing frequency and severity rates and reporting accidents.

Education should not be neglected as a factor in the promotion of safety, stated D. R. Schooler, superintendent, Centralia Coal Co., Centralia, Ill. Safety rules should be posted and strictly adhered to. Supporting other advocates of a standard method of reporting accidents, Mr. Stedelin observed that one of the hardest tasks of the management of companies carrying their own insurance is to overcome the attitude that accidents do not cost anything anyhow. In response to a question by C. J. Sandoe, vice-president, Perry Coal Co., St. Louis, John E. Jones, safety director, Old Ben Coal Corporation, Benton, Ill., stated that a study by the Illinois Mining Investigation Commission covering a period of years showed that mines employing ten men or less had double the fatality rate per 1,000 men as compared with shipping mines.

Coordination Not New Problem

The problem of coordination in the distribution of mine cars, said Howard Lewis, general underground superintendent, Old Ben Coal Corporation, West Frankfort, Ill., antedated the mechanical age in the coal industry. With the mule, however, it was a question of a fraction of an hour, whereas with modern mechanical loaders coordination is measured in fractions of a minute. In servicing loaders, Mr. Lewis pointed out, "straight switching," in which the room tracks are connected through the various crosscuts, thus permitting delivery of an empty car to the loader without the "backswitching" necessary when room tracks are not thus connected, results in a material saving in car-changing time.

Time studies cited by Mr. Lewis showed for backswitching with cars averaging 3.14 tons each the following: average time to load car, 105 seconds; average changing time, 53 seconds; switching speed, 155 f.p.m.; partial straight switching, 3.64-ton cars—average loading time, 96 seconds; average changing time, 35 seconds; switching speed, 477 f.p.m.; complete straight switching (one place excepted), 3.63-ton cars—average loading time, 97 seconds; average changing time, 27 seconds; switching speed, 363 f.p.m.

Straight switching involves an increased tracklaying cost, but "lessening derailment of empty cars during the haste in backswitching is alone sufficient to more than pay for this added track cost." Other advantages of straight switching include great flexibility in picking up rooms in case of roof falls along haulageways or at the face and elimination of the follow-

ing: failure to throw switches, with consequent loss of time; hazards and losses involved (in trolley-wire mines) in raising up and hauling under locomotive cables; and the coupling of cars in small trips in the vicinity of the loading machine and its noise.

In response to a question by Raymond Mancha, Jeffrey Mfg. Co., Columbus, Ohio, as to whether, in view of the short changing time, the car did not have to wait while the loader was changing position, Mr. Lewis stated that about 27 to 32 seconds was all that the machine required. Each loader is served by two locomotives, each with separate crew. With a small car, said Mr. Stedelin, room tracks at his mine are connected through each crosscut and two mules serve each loader. A small hoist on the loader is used to pull the car under the boom and Mr. Stedelin expressed the belief that such equipment might be of value at other operations. Two mules have handled 135 to 140 cars at slightly over 2 tons per car. In wide work at the Valier Coal Co. mine, said D. W. Jones, electrical engineer, Valier, Ill., two locomotives average 100 4-ton cars per shift. Only one triprider is employed for both locomotives, and he stays on the parting to switch the cars. Output from narrow places is not as great as from wide places, as in this case time required for loader adjustment begins to cut into available changing time.

Analyzing Degradation Problems

"Factors Affecting Sizes of Coal Produced and Methods of Control" was the principal subject at the afternoon session, at which Mr. Jones presided. In addition, Mr. Lyons described the underground broadcasting of safety messages at three Bell & Zoller mines (*Coal Age*, June, 1936, p. 236). "Potential breakage of a given coal can be indicated fairly well by drop-testing a representative sample of it, provided such drop tests are made under carefully standardized conditions," asserted Prof. C. M. Smith, University of Illinois, Urbana. Detailing the drop-testing method developed in the University Engineering Experiment Station laboratory, Prof. Smith offered the figures on percentage degradation of Illinois coals listed in Table I. The figures were derived from a limited survey of the various fields of the State.

The Illinois tests also showed that samples drop-tested after storage of several weeks were one-fifth more friable than freshly mined samples. Decreasing degradation is accompanied by an increase in mean size of output. Carrying the investigation still farther, coal from two strip mines showed a degradation of 22.3 per cent and a mean size of output of 3.60 in., against coal from four deep mines with an average degradation of 17.8 per cent and a mean size of 2.93 in.

The Orient mines in Illinois always have used the inclosed-panel system, with panels made up of two entries 12 ft. wide on 40-ft. centers, from each of which sixteen rooms, also on 40-ft. centers, are driven 250 ft. deep, said L. A. Hill, Chicago, Wilmington & Franklin Coal Co., West Frankfort, in introducing an analysis of the effect of cutting and shearing on size production. Under the hand-loading system, all rooms were driven abreast. With the adoption of mechanical loading, however, the territory off each heading from Nos. 9 to 16 rooms,

Table I—Average Size Degradation by Districts and Seams in Illinois

District	Seam	Average Size Degradation, Per Cent
Northern Illinois.....	No. 2	22.5
Fulton, Tazewell, Peoria counties	No. 5	17.9
Sangamon County.....	No. 5	25.3
Macoupin, Madison, St. Clair counties.....	No. 6	19.8
Perry, Jackson, Franklin, Williamson counties.....	No. 6	16.8
Vermillion County.....	No. 6	21.7
Saline and Gallatin counties.....	No. 6	19.5

Table II—Comparative Size Percentages, Hand- and Mechanically Loaded Coal, Central Illinois

	Under-cut Hand Loaded	Produced by Mobile Loaders
6-in. lump.....	21.30	10.09
6x3-in. egg.....	26.26	17.22
3x2-in. nut.....	9.30	19.32
2-in. screenings.....	43.14	53.37
1-in. screenings.....	32.52	43.75

inclusive, is assigned to a complete loading unit. During the mining of this group of rooms, Rooms 1 and 2 are driven 160 ft.; Rooms 3 and 4, 80 ft.; and Rooms 5 and 6, to their full depths. Nos. 7 and 8 rooms are omitted, leaving a solid pillar to localize the effects of caving when Rooms 9 to 16 are mined out. In mining the outbye half of the panel, six short places are driven off No. 6 room into the 100-ft. pillar. In addition, two places are driven off No. 5 room toward No. 2 room, heading off Nos. 3 and 4 on each entry. With this method of mining the outside half of the panel, sufficient working places for the two loading units are available until the panel is finished. Roof weight also has been reduced and recovery speeded up, with less crushing of coal at the face and consequently a better size yield. But while the system makes available sufficient working places for two loading units, said Mr. Hill, it results in traffic congestion in the area.

Installation of mechanical loaders brought the question of face preparation to a head, as undercutting and shooting in accordance with hand-loading standards left the coal in condition requiring considerable digging, with consequent decrease in output, increased breakage and more wear and tear on the machine. If the coal was shot hard enough to ease the burden on the loader, the output of 2-in. screenings was increased 10 to 15 per cent over the hand-loading figure. As a result, it was decided to go to shearing in addition to undercutting.

First equipment used were center-shearing machines, which, while adding to congestion, reduced the minus 2-in. screenings 5 per cent and increased loader capacity 10 to 15 per cent. Arcwall cutting and shearing machines were next adopted and, in addition to other advantages, reduced 2-in. screenings 7 per cent and increased loader capacity about 25 per cent over un-sheared shortwall coal. A major drawback, however, was inability to shear on a curve, Mr. Hill declared, which led to the adoption of an "arc-shear" machine that would meet that specification.

Two years ago the coal saw was tested in the West Virginia mines associated with the company and later in the Illinois operations. Double shearing with these machines "was very satisfactory," with the result that two late-type universal cutting and shearing machines evolved from

the original design are now in service, each cutting and shearing for two loaders. Loader capacity has been increased 35 per cent over un-sheared shortwall coal and 2-in. screenings have been reduced 12 per cent. The machines make a 4-in. kerf.

At present, Mr. Hill stated, the machines are used in making an undercut and two shearing cuts in 24-ft. places. The right rib is sheared 11 ft. from the center, gripping the shear 1 ft. to the right. The left shear is made 3 ft. from the center and is gripped to the left about 4 ft. "We do this in preference to turning the bar over and shearing up on the left-hand rib. Two holes are drilled at the left rib and shot first. Then four holes are shot in the block of coal between the two shears. This method of preparing the face coal affords excellent loading conditions and a very good quality of coal with a minimum of fines."

"With the advent of mechanical loading," observed Joseph Lenzini, Bell & Zoller Coal & Mining Co., in detailing the drilling and shooting practices at the company's Zeigler mines, "the coal industry was confronted with the problem of producing a grade of coal as good as or better than was being produced by hand-loading methods and at the same time not retard the loading." At the Zeigler mines, permissible powder and cushioned blasting were first adopted; next, snubbing pans, snubbing shots and permissible powder; next, center shearing with converted breast machines and Cardox. As a result of experience with these various systems, shortwall cutting and low-pressure Cardox shooting were selected. Cutters, one with each loader, are equipped with 8½-ft. bars making a 5½-in. kerf.

Shoot Rooms with Six Holes

Rooms 25 to 28 ft. wide are shot with six holes, three across the top and three across the bottom. Top rib holes are drilled straight in on the same level as the seam of coal to a depth about 1 ft. shorter than the undercut. The center hole is drilled half way between the rib holes on the same level to the same depth. The center hole in the bottom, or snubbing, row is drilled low enough to break the coal up well in the center, and to assist in this process a block about 12 in. long is driven up tightly in the undercut under the hole. Outside holes in the lower row are drilled about 6 in. nearer the ribs than the top holes, and are started as low as possible without placing an undue burden on the top holes. If the coal is seamy, the snubbing holes can be started slightly higher and angled down to prevent the charge from escaping along a seam and setting the coal down in a slab.

Narrow places are drilled with five holes: two top holes; two snubbing holes, one higher than the other; and one angle hole drilled from one rib toward the center from a point about 24 in. up from the bottom or 12 in. down from the top, according to the character of the coal. Tight coal, said Mr. Lenzini, results from the following: places off sights; improper cutting and drilling—faces should be square, ribs straight, bottoms level, holes should be properly placed, not drilled too deep, not tight and should not be overloaded or shot in improper order; shooting more than one shell at a time; failure to bug-dust; failure to block under snubbing shot; impurities in the coal; etc.

Reviewing the causes and history of mechanical loading and mechanical cleaning in

Illinois, J. W. Starks, Peabody Coal Co., Taylorville, Ill., offered data on the percentage of sizes produced under hand- and mobile-loader conditions in central Illinois (Table II). Production during the month was over 100,000 tons at each mine. "Any mining man," Mr. Starks averred, "is aware of the fact that the increase or decrease of amount of screenings varies as the amount of powder used in shooting and the extent of snubbing. In hand loading, the coal usually was snubbed to some extent and such snubbing reduced the need of heavy shots, and more lump sizes were produced. In mechanical loading snubbing is not much in use. For free loading more powder is necessary, with a resultant increase of finer sizes.

"Whatever we would like to believe, the loading machine is not a mining machine and any person expecting to get full tonnage from a mechanical loader must expect increased screenings and a decreased amount of lump sizes. It is absolute folly to force a loading machine to mine coal, as decreased tonnage will increase the cost of production and abuse of the machine will add to the cost of maintenance."

The problem of tippie handling of coal, declared L. von Perbandt, Allen & Garcia Co., Chicago, "begins after the coal has been placed in the mine cars and is ready to start on its way from the mine bottom." The present trend toward mechanization, he stated, makes it unnecessary to weigh the coal separately in weigh pans, thus eliminating one step causing considerable degradation. But machine loading also results in reduced mine-car capacity, requiring faster hoisting and dumping if the deficiency is to be made up, aggravating a major degradation factor and leading to serious consideration of smoother hoisting equipment, "such as a skip." Where skips are not practicable, "much can be done to eliminate rough handling by the use of long-radius dumping horns and with overturning cages when using closed-end mine cars." This type of equipment, however, requires a reduction in speed during the actual dumping period.

In the preparation plant, the heavier, slower-speed shaker screens have been found satisfactory for sizes down to 1½ in., but to avoid blows to the coal careful attention should be paid to the use of rounded

corners and deflecting plates with very shallow angles in the design of chutes and transfer points. Screen and dead plates should have a gentle slope to keep down the speed of the lumps, drops should be reduced to a minimum and careful consideration should be given to fitting gates and placing obstructions in the flow of coal.

"In general, the tippie handling of coal is governed by the markets it has to serve and the physical characteristics of the property. It always is advisable to avoid the making of degradation and the installation of units that will increase this tendency. Many mines are limited as to available track space and inability to increase the number of tracks and have, therefore, resorted to bins, with their consequent breakage of coal, in place of providing a sufficient number of tracks to permit the loading of all sizes directly to cars by means of loading booms."

Hanna Opening New Mine

Development work has been started by the Hanna Coal Co. on a new mine in Jefferson County, Ohio, to be known as its Dun Glen operation. The new mine, located near the old No. 1 Dillon operation, will use mechanical loaders underground. The Dillon tippie will be abandoned and a modern all-steel cleaning plant erected. Present plans call for washing the 4x½-in. coal, and the wash box used at Fairpoint No. 9 probably will be transferred to Dun Glen. Production will start late this summer or in the early fall on a double-shift basis. By next spring it is hoped to have output on a par with other Hanna operations in the eastern Ohio field.

Anthracite Kolstoker Ready

A new anthracite model of the Anchor Kolstoker has been introduced by the Anchor Stove & Range Co., New Albany, Ind. Furnished in either the standard type or with automatic ash removal, it is designed for use with steam, vapor, warm-air or hot-water heating systems, or high-pressure boilers. It can readily be installed with any new equipment or any heating plant now in service.

Allied Industries Take Part in Stoker Makers' Convention

For the first time in the history of the Stoker Manufacturers' Association, coal operators, railroad traffic officials and members of other allied industries took part in one of the sessions of the nineteenth annual meeting of the association, held June 11-13 at White Sulphur Springs, W. Va. Such an earnest spirit of cooperation was in evidence that it is planned to hold future meetings of the association in cooperation with these allied industries. It was voted to make a financial contribution to the program of Bituminous Coal Research, Inc., for the current calendar year and also to the Committee of Ten—Coal and Heating Industries, of which the association is an active member.

Approval was given to a new form of reporting stoker sales to the U. S. Bureau of the Census. The new form, which has the tentative approval of Census Bureau officials, will make a more complete breakdown of stoker sizes and will enable stoker manufacturers and others to learn the sales of small household-size stokers separated as to those installed for burning bituminous and those burning anthracite. It is expected that the new form will be placed in effect by the start of 1937.

More Time to Public Relations

In the program mapped out for the coming year more time and attention will be devoted to public relations work through a newly created committee under the chairmanship of J. M. McClintock, manager, stoker division, Illinois Iron & Bolt Co. This committee is planning a national publicity and educational campaign among architects, builders, contractors and allied trades in an effort to speed up public acceptance of the automatic coal stoker.

Engineering projects in which the association has participated were enumerated and discussed in the report of the engineering committee, headed by T. A. Marsh, central division engineer, Iron Fireman Manufacturing Co. These projects include American Standards Association Sectional Committee B-50 project, "Combustion Space for Solid Fuels"; standardization of stoker specifications for testing purposes in connection with the work of the committee on standards of performance, Bituminous Coal Research, Inc.; coal selection charts under the sponsorship of the National Association of Purchasing Agents and sectional committee of American Standards Association with particular reference to stoker-fired coal; standardization of stoker ratings with particular reference to hot-water, steam and warm-air capacities for heating of space; and correlation of data and studies with respect to stoker firing of coal.

In connection with the last-named problem, the engineering committee of the association, by resolution at the meeting, was appointed as a special committee to join with the coal industry in making a national study of this problem in an effort to provide simpler specifications covering the satisfactory sizes of coal for stoker use. Reference to this study was made also in connection with a project now under way in Chicago under the auspices of the Midwest Stoker Association, which proposes to provide simplified methods of selecting proper sizes of stoker coal by means of a

Anthracite model Kolstoker with automatic ash removal

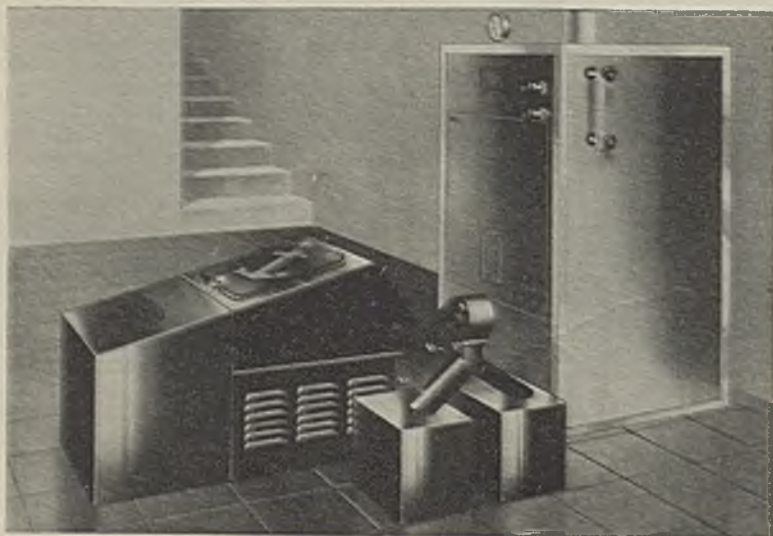



Burton Holmes Films

United Electric officials receive Holmes safety certificates

Long Safety Record Honored

A Holmes certificate in recognition of the long safety record of Fidelity No. 11 mine of the United Electric Coal Cos., at Duquoin, Ill., was presented to the mine staff of the company on June 12 by Daniel Harrington, chief, health and safety branch, U. S. Bureau of Mines, and secretary of the Joseph A. Holmes Safety Association. The mine, a large stripping operation, has a record of operating 1,202 days between September, 1929, and April 30, 1936, producing 5,602,047 tons of coal, removing 84,596,531 tons of overburden and using 4,656,255 lb. of explosives with no fatalities and only 61 minor accidents.

Safety Meets Scheduled

West Virginia's annual State mine-rescue and first-aid meet will be held Oct. 17 at Morgantown, according to P. D. McMurrer, State Safety Director. Sectional safety contests are scheduled as follows: Monongahela Valley Mining Institute, Morgantown, July 18; Central West Virginia Mining Institute, Jackson Mill, Aug. 1; Coal River Mining Institute, Sept. 5; Panhandle Mining Institute, Wellsburg, Sept. 12; New River and Winding Gulf Mining Institute, Beckley, Sept. 9; Kanawha Valley Mining Institute, Montgomery, Sept. 26; Preston County Mining Institute, Silver Lake Park, Oct. 3.

Industrial Notes

MACWHYTE Co., Kenosha, Wis., has appointed the INTERMOUNTAIN BELTING & PACKING Co., Denver, Colo., its distributor in Denver territory.

MORRIS MACHINE WORKS, Baldwinsville, N. Y., announces that changes in its executive personnel incident to the death of Windsor Morris have resulted in the election of Carl Lager as president and Pierce J. McAuliffe as vice-president and general manager.

JULIUS KAHN, president of Truscon Steel Corporation since he founded it, three years ago, has resigned that position to become vice-president in charge of product development of Republic Steel Corporation.

L. W. GROTHAUS has been elected vice-president of Allis-Chalmers Manufacturing Co. after 32 years' association with the company. He has successively worked in the Norwood shops, purchasing, drafting, engineering and sales divisions. He was

made general representative of the company in 1931 and assistant to the president in 1933.

Boston Woven Hose & Rubber Co. announces the addition to its sales and engineering staff of STANLEY M. MERCIER, for many years identified with sales, engineering and construction of conveying systems for the Jeffrey Mfg. Co.

Robins Conveying Belt Co. has made a sales agreement with the MINE & SMELTER SUPPLY Co., of Denver, Colo.; Salt Lake City, Utah, and El Paso, Texas, for the sale of Robins equipment in Arizona, Colorado, Montana, New Mexico, Utah, Wyoming and parts of Idaho, Nebraska, South Dakota and Texas.

Fuel Analysis-Classification On A.S.T.M. Program

An address on "Relationship of A.S.T.M. to Modern Developments in Chemical Engineering," by H. C. Parmelee, editor, *Engineering and Mining Journal*, will be a feature of the 39th annual meeting of the American Society for Testing Materials, to be held June 29-July 3 at Chalfonte-Haddon Hall, Atlantic City, N. J. Nineteen sessions will be held. Officers for the coming year will be elected and reports will be presented by the Sectional Committee on the Classification of Coals and Committee D-5 on Coal and Coke, of which A. C. Fieldner is chairman.

The Classification Committee report will present a new tentative method for designating the size of coal from results of screen-analysis tests of samples taken to represent the condition of the coal as sold. It will propose revisions of the tentative specifications for classification of coals by rank. Considerations being given to preparation of classification of coals according to type will be reported briefly, as also will studies being made on correlation of scientific classification with use classification of coals.

The report of Committee D-5 will present a tentative revision of the test procedure for determination of volatile matter in coal and coke; will report the formation of a new committee on dustiness of coal and coke; and will include brief summaries of the activities of various subcommittees.

LETTERS To The Editor

Snug-Fitting Clothes for Safety

Locate a hazardous practice and apply the remedy before the accident instead of waiting for action till after its occurrence. An ounce of prevention is worth a pound of cure.

All machinemen and their helpers face an accident of some sort if they do not wear breeches or snug-fitting clothing while on duty. With long trouser bottoms there is always the danger that these bottoms will catch or snag on something and throw the worker headlong on bits in motion, or in some other dangerous position. Speaking from the viewpoint of a man working with cutting machines, snug-fitting clothes should go with hard-toed shoes and goggles.

HARRY NORTHOVER
McDonald, Pa.

Gravity Methods Also Successful

I read with interest your editorial in the May issue of *Coal Age* entitled "Geophysical Windows." Your article deserves credit for mentioning modern prospecting methods which to my knowledge have not been applied as extensively in the coal industry as in metal mining and the oil industry, and it certainly would be worth their while if mining engineers and geologists who are

particularly familiar with the problems of the coal industry looked further into the possibilities of geophysical methods of subsurface prospecting.

You mentioned already the resistivity methods and the success of seismic exploration work in connection with the locating of coal seams underground. May I call your attention to the fact that gravity methods have also been used successfully in coal prospecting? Prof. Matsuyama, of the Imperial Japanese Academy of Science, reported about some interesting torsion balance work at the Fushun collieries, in Manchuria, several years ago. H. Seblatnigg wrote an article on the determination of faults with the torsion balance in the soft-coal district of Borken, Germany, as reported in the *Zeitschrift für Braunkohle* (1929, No. 23), and H. Haalck commented on this work in his "Lehrbuch der angewandten Geophysik" (Gebrueder Borntraeger, Berlin, 1934, pp. 94-97).

Modern prospecting equipment and competent geophysical engineers should make it possible to render a valuable service to the coal industry, in the search for new deposits, in a similar way as has been the case in metal mining and the oil industry in America and many other parts of the world.

G. STUBBE,
American Askania Corporation,
Houston, Texas