

COAL AGE

Established 1911—McGraw-Hill Publishing Company, Inc.

DEVOTED TO THE OPERATING, TECHNICAL AND BUSINESS PROBLEMS OF THE COAL-MINING INDUSTRY

SYDNEY A. HALE, *Editor*

May 1938



Why Cincinnati?

EVERY YEAR the Cincinnati convention and exposition of the American Mining Congress serves as a post-graduate course in mining methods and equipment. Every year it offers an opportunity to get abreast with the progress of the industry. At Cincinnati the coal men can see not only the most recent innovations in machinery but also the improvements which have been made in standard types of equipment to better performance, increase output per man and lower production costs. With inter-fuel competition so pressing, no operator touched with a progressive spirit dare rest content with last year's technique. The Cincinnati convention which starts May 2 presents an ideal forum for the discussion and study of what is newest and best. Be there!

Self-Interest

IN CAMPAIGNING to recapture tonnage lost to oil in New England markets, the National Coal Association is on firm economic ground when it appeals to the self interest of the manufacturers who have shifted to competitive fuels. The coal and railroad industries rank unusually high in the percentages of their revenue dollar which promptly flow back into the general buying stream as payments for wages and supplies. Any substantial depletion in mining or railroad income is quickly reflected in decreased purchasing power which directly or indirectly affects all classes of manufacturers and merchants.

Since this is so, it should not be difficult to demonstrate that the over-all effects

of this diminution in buying power far overbalances any small saving the average manufacturer may make in unit-production costs by changing over to some other form of energy. Unfortunately, it is not always easy to impress this truth upon the individual business man. Too often he prides his own independence so highly that he is indifferent to the interdependence of all industry. As a result, he acknowledges the soundness of the argument but remains unconvinced.

That unwillingness to recognize the impact of seemingly remote causes upon individual business prosperity, however, should not discourage those who are trying to dramatize inter-industry relationships. The country can hardly hope to achieve a more stable national economy unless this lesson is driven home. But the process of education would be swifter if rail rates and coal prices could be lowered to a point where even an immediate trifling reduction in manufacturing costs with competitive fuels could be wiped out.

Not Knowing How

DESPITE a common language and a long mining background, British shotfirers are said to be none too efficient. The Scottish divisional inspector recently gathered several of them together in a safety-lamp mine and, after warning them of his intentions, asked each of them to demonstrate exactly with the aid of full-sized replicas of a shot-hole and dummy explosives just how he would proceed to fire a shot in a coal face. Although the men entered into the spirit of the test, not one succeeded in scoring 65

per cent of the total marks and one fell below 32 per cent. "All the firemen tested," the inspector declares, "were intelligent and capable men."

Such tests are worthy of imitation at our own coal mines. With the medley of languages in American mining communities, the sometimes inadequate training of supervisory forces and the fact that many of the miners, both native and foreign, were originally farmers, it is not unthinkable that the rating they would receive might be even lower than at this Scottish mine and the need for training even more mandatory. Why is nearly all our training lavished on first-aid men, who, after all, only "pick up the pieces" which others, for lack of training, have scattered? Job analysis and job training are as essential as first-aid training and more fundamental.

Umbrella or Sword?

FEDERAL REGULATION of bituminous coal prices won widespread acceptance from a harassed industry on the theory that such control would make mining a more profitable and stable enterprise. The theory is a wholly commendable one. But now that the Coal Commission and the producers' boards again are in the throes of attempting to work out an official minimum-price structure, it might be well to inquire just how it is proposed to give practical application to this theory.

Such an inquiry inevitably raises sharp questions of fundamental definitions and specific procedure. Is profit to be a purely per-ton figure completely dissociated from volume? Is the protection afforded the mines with mean costs to deprive the consumer and the producer of the benefits of more efficient operations? Are mines in this group to exact prices which jeopardize their chances of increasing the volume of coal sold? And are consumers close to mines to be penalized so that those mines may shrink their prices in more distant markets?

Of course, the facile answer to all these questions is that the law itself prescribes

the basis upon which prices shall be initiated and coordinated. That, in the abstract at least, is true. Yet even in this statute-ridden land laws have been modified when experience has demonstrated that changes are essential to their successful operation. Suspension of the price schedules promulgated last winter makes any comment on what their ultimate revisions might have been highly speculative. If some of the inequities in those schedules, however, mirrored inescapable mandates of the law, then modification is in order.

For its own future salvation the industry must never lose sight of the disagreeable fact that, while Uncle Sam can fix prices, he cannot deliver customers or protect volume. That has been painfully established in the case of the railroads, who have to appeal to the Interstate Commerce Commission for higher rates when it is generally admitted that the root of their troubles is loss of traffic to other forms of transportation. The rate umbrella is raised, but it is a poor shield against rivals who cut away rail business with the sword of lower costs. Must coal regulation follow the same path and repeat the same mistakes?

Prone-Pressure Violence

GENTLE INDEED are the natural pressures on the human thorax which cause air to be drawn into and expelled from the lungs. They never cause bones to be broken. In view of this fact, what occasion is there for violence in operating them by the prone-pressure method? To use excessive force shocks the patient and may break his ribs. J. D. Hall, Atlantic City Electric Co., believes that the pressure should not exceed a quarter of the weight of the patient and that the inclination of the arms which will impose such a weight can be determined by indications on a bathroom scale. It is always necessary to remember that the patient may be deficient in calcium and that his bones may be unduly weak and brittle. Pressures should not be imposed with more zeal than knowledge.

COOPERATION IN SAFETY

+ Reduces Mona's General Injury Rate And Limits Fatalities to One in 7½ Years

OPERATION from June 27, 1930, to Dec. 27, 1937, without a single fatality is one measure of the safety work carried on at the Mona mine of the Arkwright Coal Co., on the Monongahela River three miles from Morgantown, W. Va. In this period, the production totaled 2,226,576 tons. That this record is not a freak is indicated by the fact that in the past four years, lost-time injuries per year have ranged in number from 17 to 22, with production running from 294,896 to 338,501 tons. Neither has this record required setting up an elaborate safety organization, as up until the adoption of mechanical loading last year the mine was operated by a superintendent, a mine foreman and a night boss. Another measure of the value of the work is the fact that the operation has paid no more than the minimum compensation rate for a long period of years.

A drift operation, the Mona mine recovers the Pittsburgh seam by room-and-pillar methods. In common with other mines in the region, the practice at Mona is to leave 18 to 24 in. of coal in place in the top and bottom, making the net recovery about 7 ft. Over the roof coal left in place is 3 in. to 7 ft. of drawslate, followed by the Pittsburgh "Rider" seam, averaging 12 in. in thickness. Beneath the seam is a hard fireclay. While considerable support is derived from the top coal, the roof in the mine is classed as none too good, with the result that careful and systematic timbering is a necessity.

Present production from the Mona mine is around 1,400 tons per day, of which 1,000 tons is derived from two Jeffrey L-400 track-mounted loading machines working two shifts each. In fact, the operation is now in the transition stage from hand to mechanical loading, with hand loading

and horse gathering only to finish out the old working territory.

Each loading machine is accompanied by a Sullivan 7AU track cutter and a Jeffrey 56A track-mounted drill. The drills have been modified, however, to operate with only a single instead of the normal two spindles. Each loading machine is serviced by a 6-ton Jeffrey cable-reel locomotive, and these two locomotives in turn are served by a relay locomotive, also of the cable-reel type. Normal crews consist of fifteen men.

All places, whether rooms or headings, are driven 11 ft. wide. Normal room depth is 300 ft.; centers, 60 ft. Pillars are brought back on a line of about 50 deg. with the butts, and in extracting pillars the practice is to take successive cuts across the end, leaving small stumps as protection

against the gob. These stumps are shot when a cut is completed, thus allowing the roof to cave up against the end of the pillar. When the loading machine cleans up a place, the timbers are extended and the track is laid up. Holes then are drilled and the place is top cut to maintain the coal roof. Finally, the shotfirer loads and shoots the holes. Cleaning up after the loader seldom is necessary, and when required is done by the timber- or track-men.

Operation of the first loading machine started Aug. 18, 1937, and, in addition to the installation of equipment new to the men at the mine, required a material readjustment in thinking and working habits, as well as the employment of additional crew foremen to oversee the operation of the machines. As compared with

Loading machine starting a cut across the end of a chain pillar. While mechanization involved a major change in operating practices and thinking at Mona mine, injuries have been few. Men on the machine, in accordance with standard practice, wear electric lamps and safety head and footgear.

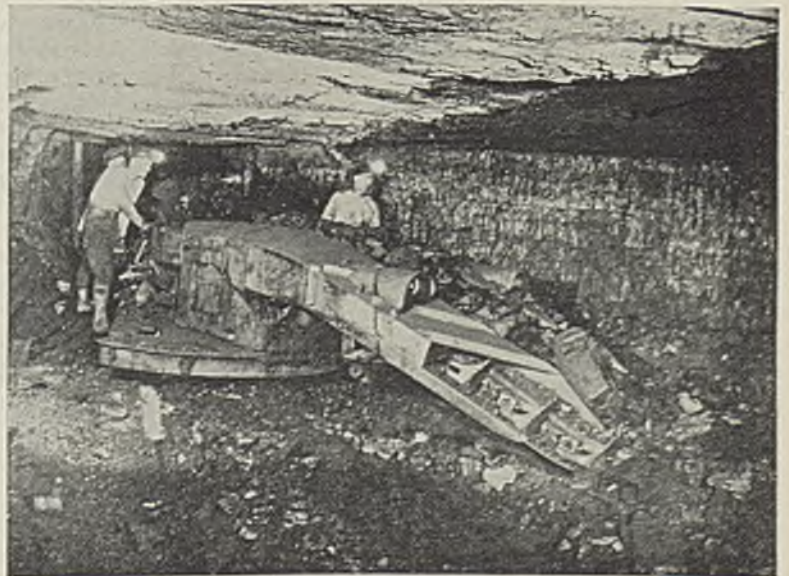

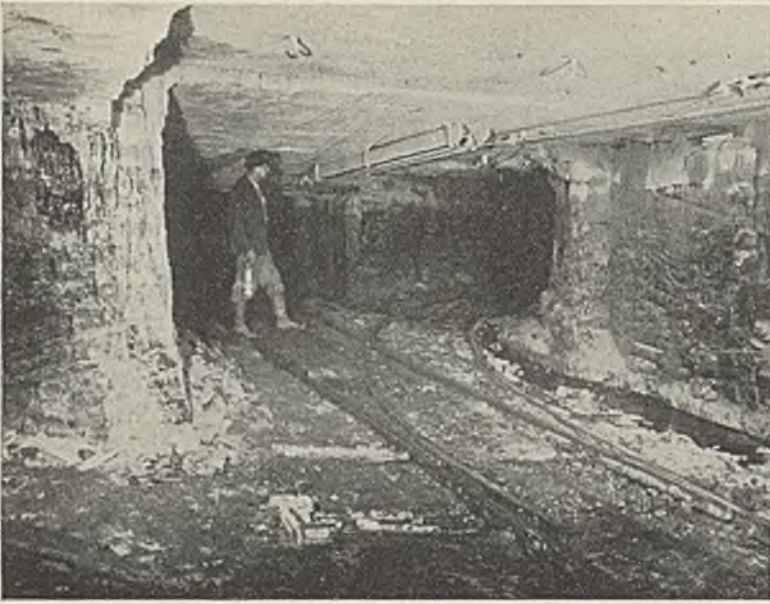

Butt heading in the machine section, Mona mine, showing parallel throw on the switch, guardboards on the trolley wire over a turnout into the parallel heading and rock dust on the ribs, top and floor. All places with track are rock-dusted every week end.

hand-loading practice, the major changes revolved around the introduction of locomotives for gathering and the continuous operation of several pieces of machinery at a time in a working section, together with the necessity for a number of electric circuits in the form of trailing cables. Rail size was increased from 20 to 40 lb. laid on steel ties, including West Virginia steel-tie turnouts. Anticipating the possibility of future regulations to that effect, permissible equipment was chosen for the mechanized working territory, and permissible explosives (Duobel C) with electric shotfiring are the practice.

Considering that both management and men started from scratch, the fact that only four lost-time injuries have occurred in the mechanized territory in the course of producing 101,113 tons to March 15, 1938, speaks well for the thorough grounding in safety principles gained by the operating personnel over a period of years, and shows that the training period in mechanization need not be a period of high injury frequency. One of the four injuries in question resulted fatally, but under circumstances which indicate that it was not directly a result of the operation of the loading machine or auxiliary equipment. In fact, the loader was back from the face and was idle at the time the man, who was engaged in picking down coal, was killed by a fall of roof, which apparently was in as good condition as could be expected in the normal working place. As a matter of coincidence, the pre-

vious fatality 7½ years before occurred under almost identical conditions in the corresponding room about 300 ft. distant across the barrier pillars along the 5th Left entry off the 3d South. From the standpoint of changes in the nature of the hazards with the change to mechanical loading, one of the most frequently encountered types of injuries in the mechanized section is mashed fingers, which in almost all cases are not severe enough to result in loss of time.

The keynote of the safety work at the Mona mine is the principle that the safety of the individual in the last analysis rests upon himself, as it is impossible to oversee constantly the activities of each and every man. Consequently, the management has taken upon itself the responsibility of developing this safety philosophy along with the accompanying responsibilities of backing up recommendations for the elimination of hazardous practices and keeping mine workings, surface plants and equipment in both safe and efficient condition. Men are given a voice in the establishment of special regulations in addition to certain general rules and the principles laid down by the State mine law. Close co-operation with the State inspection department in the institution of safety practices is another Arkwright principle, and, furthermore, sufficient flexibility is incorporated in the safety system to permit adoption of new safeguards as fast as they are developed or the need of them appears.

From the standpoint of safe physical conditions, the program starts with good housekeeping, which includes regular cleaning of tracks and travelingways, keeping material as far as possible out of the roads which men must use, etc. Complete inclosure of all moving parts on machinery in tippie, headhouse, other surface plants and elsewhere is the rule. Underground, the trolley wire is set at least 6½ ft. above the rail and is protected by guardboards at all crossings, including every cross-over track along butt entries. Platforms with insulator legs and rubber-mat surfaces are prescribed for every electric switching and telephone station. Cut-out switches are installed in the circuits to every butt entry, with sectionalizing switches elsewhere as required. Explosives are hauled in an insulated powder car, further protected by the use of insulating hitchings. All trailing cables, with the exception of those on locomotives, are equipped with fused nips. Locks are used on all cutter chains while moving machines.

Ample Clearances Provided

In compliance with State regulations, clearances of at least 30 in. from the car are carried on one side of all openings, with manholes at least 6½ ft. deep from the rail on each side of every door and at every switch. As many doors as possible are being eliminated, and those remaining are being equipped with glass windows, another recent suggestion of the State mining department. All switches in the mechanized workings are equipped with parallel throws, and throws on other earlier tracks, particularly main lines, are being changed to the parallel type. Cinder-block stoppings are the standard practice along all permanent or semi-permanent airways, both for their fireproof qualities and resistance to air leakage.

Examples of measures taken to improve physical conditions might be multiplied at length, but the above give an indication of the extent to which they are employed at Mona mine. In the working places, great stress is laid on proper timbering and ample supplies of props are made available at all times. In the loading-machine sections, the loader is followed, as indicated above, by the timberman, with the provision, of course, that he will accompany the machine at any time his presence is deemed necessary. But to make sure that top conditions are properly taken care of, both drilling and cutting crews are supplied with the axe

and saw, and are expected to set any additional props which may be necessary when they complete examination of the place.

Rock-dusting is a regular week-end event at Mona mine, and all places with track in them are dusted to the face with an M-S-A machine each and every week. This dusting is to be supplemented with barriers in all airways or headings without track.

As in the case of physical safeguards, a lengthy list of working rules, including both those required by the mine law and the State inspection department, as well as those placed in effect by the company to meet special conditions, might be cited. One rule on which major stress is laid, however, is careful inspection of working places. This is made necessary by the character of the top and other conditions, which in turn is reflected in the fact that miners and other men whose work takes them into these places suffer the greatest number of injuries, as indicated in Table I. These injuries, however, are not primarily those growing out of falls of top, face or sides, but also result from lifting, pushing, shoveling, falling, etc., which have led to the institution of educational measures and operating regulations designed to instruct men in the proper methods of handling material, keeping places clean, and the like.

Regulations Promote Safety

Aside from miners, cutters stand about third in the list of employees subject to injury, but in many cases these injuries arise from causes which also predominate in the miner group, rather than from causes peculiar to the operation of mining machines. Transportation men, primarily drivers and snappers, follow miners in the number of lost-time injuries, and in their cases the injuries are largely due to their special duties of handling cars and locomotives and animals. Consequently, a number of special regulations are directed toward transportation men, in addition to provisions contained in the mine law or prescribed by the inspection department. For example, coupling cars on the fly is prohibited, along with dragging cars on the ground until they rerail. Both measures, incidentally, make for greater efficiency in operation. Getting on and off trips, coupling on curves or in close places, riding on locomotives, bumpers or in cars, backpoling, etc., are strictly governed or prohibited, as the case may be, to

reduce the possibility of injury. All locomotives and other track-mounted equipment are equipped with lifting jacks for rerailing purposes, and jumpers, ties, etc., are banned.

Interest in the safety idea is kept alive and men are provided with an opportunity to have their say—an important element in maintaining interest—primarily through a chapter of the Joseph A. Holmes Safety Association. This chapter was organized on March 8, 1934, and, while not the earliest in the region, is one of the four still active out of a total of fourteen at one time. In fact, the Mona chapter has never missed a meeting, held once a month, since it was organized. Once each year the general public is admitted and, if possible, some outside safety topic, such as highway or home safety, is discussed by an outside speaker. At the other regular eleven meetings, injuries, if any, in the preceding month are analyzed and measures to prevent a recurrence are adopted, along with any other recommendations for improving safety conditions. Then, if possible, a safety picture is shown or a talk is made by an outside speaker, or, if one is not available, by a foreman or mine employee. Some form of entertainment winds up the proceedings.

Another method of stimulating safety is first-aid training. The first 100-per-cent first-aid training program was put on at Mona mine starting Feb. 22, 1929. In accordance with the usual practice, key men

were first trained in cooperation with representatives of the U. S. Bureau of Mines and the West Virginia Department of Mines, these key men then instructing the rest of the employees. The second 100-per-cent campaign was started Sept. 29, 1933, and plans call for another campaign later this year. In the meantime, special classes have been held for employees without previous training.

Two major first-aid stations are maintained at the mine, complete with stretchers, splints and other materials necessary for handling severe injuries. In addition, the company adopted some years ago the practice of issuing a small first-aid kit to every employee, replenishing the supplies as fast as they were used. Two major reasons dictated this move. One was that employees were scattered under the hand-loading system, and the plan made material available to all. The other was that fitting each man with a kit made it more likely that small cuts, lacerations, etc., would receive immediate treatment. This, together with the practice of reporting all injuries, no matter how small, was designed to prevent infections, which in a few instances have made what would have been only minor injuries into major lost-time cases. With the advent of mechanization and the concentration of the working force in a small area, the need for the original system of supplying first-aid kits is not so pressing and therefore the management has under consideration the adoption of locomotive kits or

Table I—Lost-Time Injuries by Causes and Occupations Since 1933, Mona Mine

	1934	1935	1936	1937	Jan. 1— Mar. 15, 1938
Injuries by Causes:					
Falls of top.....	2	..	2	2*	..
Falls of side or face.....	2	2	3	1	..
Pushing, lifting or shoveling.....	2	4	2	3	1
Mine cars and locomotives..	5	2	1	2	..
Animals	1	..	1	1	..
Track	1	1
Cutting machines	2	2	3	1	1
Loading machines	1	..
Slipping or falls of persons..	..	3	2	1	..
Flying coal or objects.....	..	1	3
Timber	1	..	1	1
Electricity	1
Repairing machinery	1	..	1	..
Miscellaneous underground..	1	3	1
All surface causes.....	2	1	3	3	..
Total	18	22	21	17	3
Injuries by Occupations:					
Miners	8	13	13	5	1
Cutters	2	3	3	1	1
Snappers	4	2	..	1	1
Drivers	2	1	2	2	..
Repairmen	1
Motormen	1	..
Trackmen	1	..
Mechanical mining:					
Loader helpers.....	1*	..
Facemen	1	..
All surface employees.....	2	2	3	4	..
Total	18	22	21	17	3
Tonnage per Injury:					
Total tonnage.....	294,896	345,313	332,746	338,501	49,474
Tonnage per Injury.....	16,383	15,695	15,845	19,912	16,491

* Includes one fatality.

some similar system of keeping a supply of first-aid materials in the working section.

Protective clothing, of course, is an integral part of the Mona safety program, and has been supplemented since the advent of mechanical loading by the use of Model K Edison cap lamps—as much for efficiency as for their safety features. The use of

goggles was started some time ago and today they are worn by a substantial number of men at times when their work requires. Spectacle-type American Optical Co. goggles, with prescription-ground lenses when required, are the principal type used underground, with special types as required for shop men and other surface employees.

Practically all employees at present wear safety footgear, primarily Lehigh leather and rubber shoes, with 100 per cent as the goal in the near future. Safety headgear ("Cool-Caps" or M-S-A "Skullgards" or "ComfO-Caps" primarily) is worn by all men at the mine working underground and a majority of those on the surface.

WITH ENERGY USE UP + Superior Mines Add But Little To D.C. Electrical Capacity

PASSING through the various stages of hand loading, semi-mechanical loading with conveyors (pit-car loaders), and full mechanization with mobile loading machines, the Superior Coal Co., operating four mines at Gillespie, Ill., also has experienced an increase in both demand for electrical current and energy consumption per ton of output. But, despite the fact that energy consumption has doubled to more than tripled, as compared with hand-loading days, accompanied by a fair increase in demand, additions to d.c. capacity—actual or contemplated in the immediate future—have been limited to approximately 20 per cent of the capacity already in service.

Handling the increased demand and energy requirements has been made possible primarily by an underground distribution system which insures that each d.c. machine will operate on the average at as near capacity as possible. Furthermore, the system is designed to balance the load between the d.c. units in service, so that none will be either over- or under-loaded. Using a minimum of what might be termed "special" equipment, the system also assures, as a rule, a voltage of 230 to 250 at the working face, as compared with 265 at the switchboard. Voltages of much less than this are not tolerated for long, and a drop to 210 or at the most 200 is the signal for moving conversion equipment or add-

ing copper, whichever seems the most feasible and cheaper.

All four of the Superior mines recover the Illinois No. 6 coal, ranging from about 7 to 9 ft. in thickness. All are shaft operations under around 325 ft. of cover. Nos. 1 and 2 mines were opened in 1902 and 1903 and No. 3 in 1904-5, with No. 4 mine coming into production in 1918. Present capacity ratings are as follows: No. 1, 2,700 tons per day; No. 2, 3,100 tons; No. 3, 3,000 tons; No. 4, 3,300 tons. Hoisting shafts are located at about the center of the territory worked out to date, and at Nos. 1, 2 and 3, the distance from the shaft bottom to the working sections is close to two miles. At No. 4, the working sections are from 5,000 to 12,000 ft. from the bottom.

Hand loading directly into mine cars was the rule until 1928, when a start was made on equipping all mines with conveyors. This process was practically completed in 1932. The last step toward complete mechanization was taken in 1936, when installation of track-mounted mobile loading machines was started in No. 3 mine. No. 1 was the next operation to be mechanized, in 1937, followed in the same year by No. 2. No. 4 still is on the conveyor basis.

Aside from the installation of loading machines or conveyors and the elimination of the mules used for part of the gathering service in Nos. 1 and 2 mines, the only major change

in underground facilities at the Superior mines in comparatively recent times has been the installation of power-operated coal drills and the replacement of the earlier breast and shortwall cutters with arewall or slabbing machines. Track-mounted cutters were adopted because of their inherently higher productive capacity, and the results may be gaged by comparing the number of units in service in January, 1938 (Table I), with the number in use in the year 1927. At present, while some short-wall machines are on hand if required, all cutting is handled by the arewall or slabbing units, some few of which are double shifted.

Each of the four Superior mines is equipped with a boiler room and generating plant, and consequently demand is not a vital factor except from the standpoint of the ability of the generating equipment on hand to take care of it. So far, no additions to the primary generating units have been necessary. Hoists and ventilating fans are steam operated, and all major electrical equipment, including tipples, operate on d.c. current. The load represented by the tipple and other surface motors has shown but comparatively little change—in the upward direction—over a period of years.

Generating equipment and d.c. conversion units are listed by mines in Table II. It will be noted that both a.c. and d.c. units are in ser-

vice at all four operations. The a.c. equipment, however, serves only the conversion units in or near the working sections. As a general rule, the d.c. generators or converters in the power plants take care of the d.c. loads on the surface, the major portion of the haulage load and any peaks which the motor-generator sets at the face are unable to handle. In Nos. 1, 2 and 3 mines, the underground distribution systems are arranged so that the peaks are split approximately 50-50 between the face units and the d.c. generators. In the near future, however, it is expected that the load will over-balance toward the face units.

Except for some extra cutting at night, all work is done on the day shift under the Superior operating plan. The working-shift load underground consequently consists of the cutting, drilling and loading machines, main-line locomotives, of which the largest in use is 15 tons, and, at two of the mines, of the gathering and relay locomotives. At Nos. 1 and 3 mines, however, part of the gathering is done by storage-battery equipment—five such units at No. 1 and nine at No. 3, compared with four and fifteen, respectively, in 1927. Naturally, batteries are charged at night, thus reducing the day load to that extent at the two

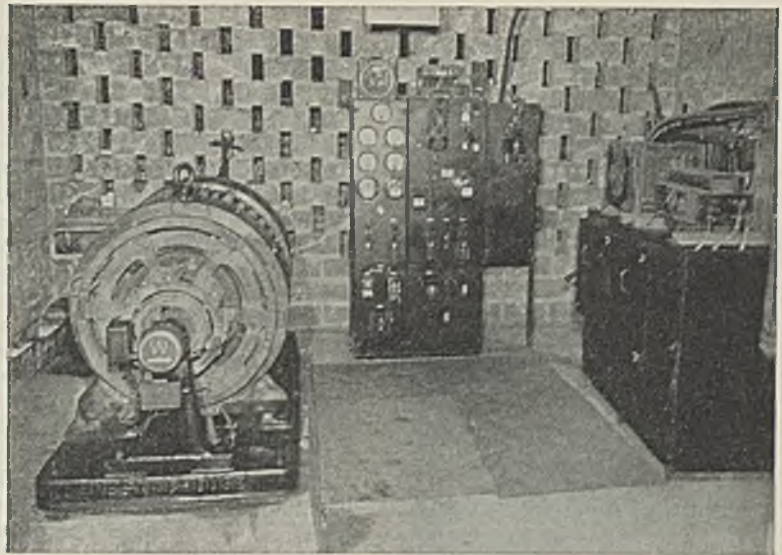

150-kw. full-automatic substation in No. 3 mine. By leaving openings in the blocks making up the front or back walls, or both, unauthorized entrance to station is prevented while air circulation is facilitated.

mines in question. Major underground equipment in 1927, 1932 and January, 1938, is listed in Table I.

Primary generating equipment is identical at Nos. 1 and 2 mines, consisting in each case of two 200-kw. 275-volt engine-driven d.c. generators and one 500-kw. 2,300-volt a.c. turbo-generator (mixed-pressure

type). The turbo-generators each serve three 150-kw. 275-volt d.c. motor-generator sets underground near the working sections. One set at No. 1 is equipped with automatic-control equipment, and automatic controls probably also will be installed on an additional 150-kw. set scheduled for No. 2 mine in the fairly near future. Eventually, it is expected that all face sets in all mines will be equipped with automatic controls, inasmuch as it is not always possible to secure reliable attendants.

Primary generating equipment at No. 3 mine consists of two 200-kw. 275-volt engine-driven generators in the power house at the top of the hoisting shaft. The mine originally was equipped with two 150-kw. motor-generator sets, which have been fitted with automatic controls. With the change to mobile loaders in 1936, an additional 200-kw. manual set was added. All three sets are located in the Main West territory, to which the two smaller sets were moved in 1937, when territory on the south of the mine was transferred to No. 4. At the other mines, one set at No. 1 was moved in February, 1938, while a move at No. 2 has been scheduled for later this year.

A.c. at 2,300 volts to operate the No. 3 m.g. sets is received from the power plant at No. 4 mine via a 12,000-ft. pole line (three 4/0 wires) and borehole. Primary generating equipment at No. 4 mine consists of two 750- and one 300-kw. high-pressure turbo-generators. D.c. conversion equipment includes two 300-kw.

Table I—Comparative Energy Consumption and Equipment in Service Underground, Superior Coal Co. Mines

Mine No. 1	1927	1932	January 1938
Total energy consumption, kw.-hr.	594,040	520,100	128,800
Production, tons	401,181	286,255	42,087
Kw.-hr. per ton	1.481	1.816	3.05
Days worked	110½	90	21
Number of locomotives, regular	23	16	19
Extra			1
Number of mules	7		
Number of mining machines	26	5	4
Number of drills		23	24
Number of conveyors		102	
Number track-mounted loading machines			7
Mine No. 2			
Total energy consumption, kw.-hr.	460,430	557,000	221,200
Production, tons	478,717	334,248	52,395
Kw.-hr. per ton	0.962	1.686	4.22
Days worked	112	100	24
Number of locomotives	10	18	18
Number of mules	37		
Number of mining machines, regular	30	13	3
Extra			2
Number of drills		15	23
Number of conveyors		111	
Number loading machines			8
Mine No. 3			
Total energy consumption, kw.-hr.	576,900	621,450	158,700
Production, tons	585,855	360,042	62,158
Kw.-hr. per ton	0.985	1.726	2.55
Days worked	118½	101	22
Number of locomotives	36	18	23
Number of mining machines	23	4	3
Number of drills		24	27
Number of conveyors		110	
Number of loading machines, regular			8
Extra			1
Mine No. 4			
Total energy consumption, kw.-hr.	622,100	417,200	136,400
Production, tons	522,970	246,121	73,888
Kw.-hr. per ton	1.190	1.695	1.85
Days worked	84½	60	21
Number locomotives	24	20	22
Number of mining machines	37	5	3
Extra			12
Number of drills		30	30
Number of conveyors, regular		142	152
Extra			18



Top of borehole near the shaft at No. 2 mine. This 8-in. hole carries a 2,300-volt a.c. cable; two 1,000,000-circ.mil d.c. positive circuits, three 500,000-circ.mil return lines (all held by one clamp), and telephone and light circuits.

rotary converters in the power house and two 150-kw. automatic and one 150-kw. manual m.g. sets on the surface over the various working sections. An additional 150-kw. set with automatic control is scheduled for No. 4, and eventually it is expected that all four sets will be moved underground. At present, the sets are served with a.c. by pole lines, the longest of which is about 4,000 ft. Two of the pole lines consist of No. 1 wires, while the third is made up of 4/0 conductors with the thought that it will be extended to serve an additional station or stations in the future. D.c. circuits are carried down boreholes to the working sections.

As a matter of fact, all circuits going down into the Superior mines are placed in boreholes, even though the d.c. units may be at the top of the shaft. Installation is simplified, it is felt. A.c. borehole cables are standard No. 6 steel-wire-armored units supported by clamps at the tops of the holes. D.c. positive circuits have the same armor with bare return cables, both supported by separate clamps in the same holes. At Nos. 1 and 2 mines, single 8-in. boreholes are used for the 2,300-volt circuit, the d.c. positive and return circuits, and the rubber-covered telephone circuits. The top of one of these boreholes is shown in an accompanying illustration.

Three-conductor cables are used for the 2,300-volt a.c. circuits underground, this practice going back to

the year 1921. Originally, steel-band-armored cables were installed. In 1926, non-metallic cable was adopted because of its lesser cost and has proved entirely satisfactory. The 1926 cable still is in service, and only one blowout has been experienced with non-metallic cable since it was adopted for underground service. This blowout was the result of an extremely heavy fall of rock. Cables are laid along the bottom in the aircourses as a general rule, and old ties and props are placed alongside them for protection.

By mines, the underground 2,300-volt circuits are as follows: No. 1, one main circuit with two branches, longest distance slightly over two miles; No. 2, one main circuit with one branch in operation and another being installed; No. 3, main circuit from bottom of borehole to 200-kw. substation with two branches, the longest about 6,500 ft. As indicated above, conversion sets at No. 4 are served by pole lines. No. 1 conductors are used in the underground cables at No. 1 mine, with 3/0 conductors in the main circuits at Nos. 2 and 3, and No. 1 wires in the branches. Non-metallic cables are installed in 500-ft. lengths, which have been found the most convenient. Joints are soldered and wrapped with self-vulcanizing tape, followed by friction tape and varnish.

Copper Keeps Voltage High

D.c. distribution practice at the Superior mines is distinguished by the use of sufficient copper to assure adequate voltage conditions at the face. Return circuits are made as large as the largest positive circuits—a necessary prerequisite for efficient operation—with the result that auxiliary returns are used in practically all cases. Substations and d.c. generators are tied together into a continuous circuit and consequently operate in parallel, balance being secured by adjusting the copper area in the tie lines as required. Provision usually is made for isolating sections of the d.c. distribution system in case of trouble and for cutting out substations when they go down and throwing the load on the other operating units. Separate circuits usually are provided for face equipment and main-haulage units.

Most of the trolley wire in service is 4/0 Fig. 8, but renewals on main lines are being made with 6/0 wire. Primary rail returns consist of 30- and 32-in. copperweld bonds, applied with resistance welders. Both rails of main lines generally are double bonded. The copperweld replaced

steel-terminal bonds, as the management considers that a better joint is secured, in addition to the fact that it is easier to remove copperweld bonds for reuse in room territories.

Bonds are inspected at least every three months, using both the eye and instruments. Voltage conditions in the working sections are checked by the electrical engineer or his assistant at least every six months, while substations get a going over every month or oftener.

Auxiliary returns are used along all trolley circuits, even in the panel entries. Along the main lines, these auxiliary returns consist of 500,000-circ.mil stranded feeder—one or two lines, as required; usually the former—tied into the track at about 1,000-ft. intervals. On panel entries the 4/0 trolley wires are paralleled by 4/0 returns, and No. 1 wires are taken off into each working place. All machine cables are hooked to these wires, rather than the usual practice of hooking the positive to the trolley and the return to the track. This practice resulted from experience showing that a track return could not always be relied upon, although it is available to supplement the auxiliary return. All cables and wires are kept off the entry and shorter trailing cables may be used, reducing cable resistance and increasing efficiency. Loading machines have only 150-ft. cables, and it has been found that the machines can make better time in moving, and

Table II—Generating and Substation Equipment, Superior Mines

	Number of Units	Rating per Unit, Kw.
<i>Mine No. 1</i>		
Surface power plant:		
Mixed-pressure turbo-generators, 2,300 volts, a.c.	1	500
Engine-driven generators, 275 volts, d.c.	2	200
Underground substations:		
Manual	2	150
Automatic	1	150
<i>Mine No. 2</i>		
Surface power plant:		
Mixed-pressure turbo-generators, 2,300 volts, a.c.	1	500
Engine-driven generators, 275 volts, d.c.	2	200
Underground substations:		
Manual	3	150
<i>Mine No. 3</i>		
Surface power plant:		
Engine-driven generators, 275 volts, d.c.	2	200
Underground substations:		
Manual	1	200
Automatic	2	150
<i>Mine No. 4</i>		
Surface power plant:		
High-pressure turbo-generators, 2,300 volts, a.c.	2	750
High-pressure turbo-generators, 2,300 volts, a.c.	1	300
Rotary converters, 275 volts, d.c.	2	300
Surface substations:		
Manual	1	150
Automatic	2	150

cable wear and tear is less. To make sure that the track return is kept in the most serviceable condition, it is the custom to bond around all room switches.

Machine and haulage circuits, as noted above, usually are kept separate, although provision naturally is made for cutting them together in most cases, if desired. All main machine circuits consist of at least 500,000 circ.mils of stranded feeder, and in some cases as much as 1,500,000 circ.mils is used. Generally, if more than 500,000 circ.mils is to be installed, two lines are put up, although some 1,000,000 circ-mil feeder is employed. The 500,000-mil type, however, is almost standard because it is easier to handle and lends itself to use in multiple. Haulage circuits consist of the trolley paralleled by one to three 4/0 wires tied in at 1,000-ft. intervals. One return serves both the machine and haulage circuits, except in the case of certain tie lines, where only single positives, accompanied by equal-sized returns, are necessary. With these exceptions, returns consist of both rails of the 40-lb. track and sufficient 500,000-circ.mil feeder lines tied in at

1,000-ft. intervals to bring the return capacities up to the capacity of the largest positive circuit.

Positive circuits naturally are suspended on insulators, but this practice also has been extended to return lines at the Superior mines. Originally, the auxiliary returns were hung in a hook on the end of an iron pin in a wooden plug in the roof. Corrosion of the return line and rusting out of the hook was encountered, however, with the result that spool-type insulators on clevis-type hangers were adopted. Clevis hangers are employed also in positive feeder systems, as this type hanger lends itself to being lengthened to accommodate any number of insulating spools and thus any number of wires or circuits which it may be desirable to hang—all from a single hole in the roof.

From the standpoint of telephone service, incidentally, steel-wire circuits have been replaced with rubber-covered copper. At No. 3, for ex-

ample, eighteen telephones were at one time in service. With steel wire, ringing was poor. The circuits were changed so that each now consists of two No. 14 rubber-covered copper wires twisted together. No trouble has been encountered since. The location of each phone is indicated by a colored lamp and the instruments are mounted in white-painted wood boxes, each fitted with two colored lamps to serve as supplementary location signals in addition to keeping the phones dry.

Superior No. 3 mine furnishes an example of the results of electrical practices at the company's mines as reflected in voltage maintenance. In the 1 N.E. section of No. 3, the voltage has never been less than 230, except for negligible intervals, even

Fig. 1—Plan of working sections in Superior No. 3 mine, showing location of d.c. generators and substations and the principal power circuits. Equipment in service underground is listed in Table I.

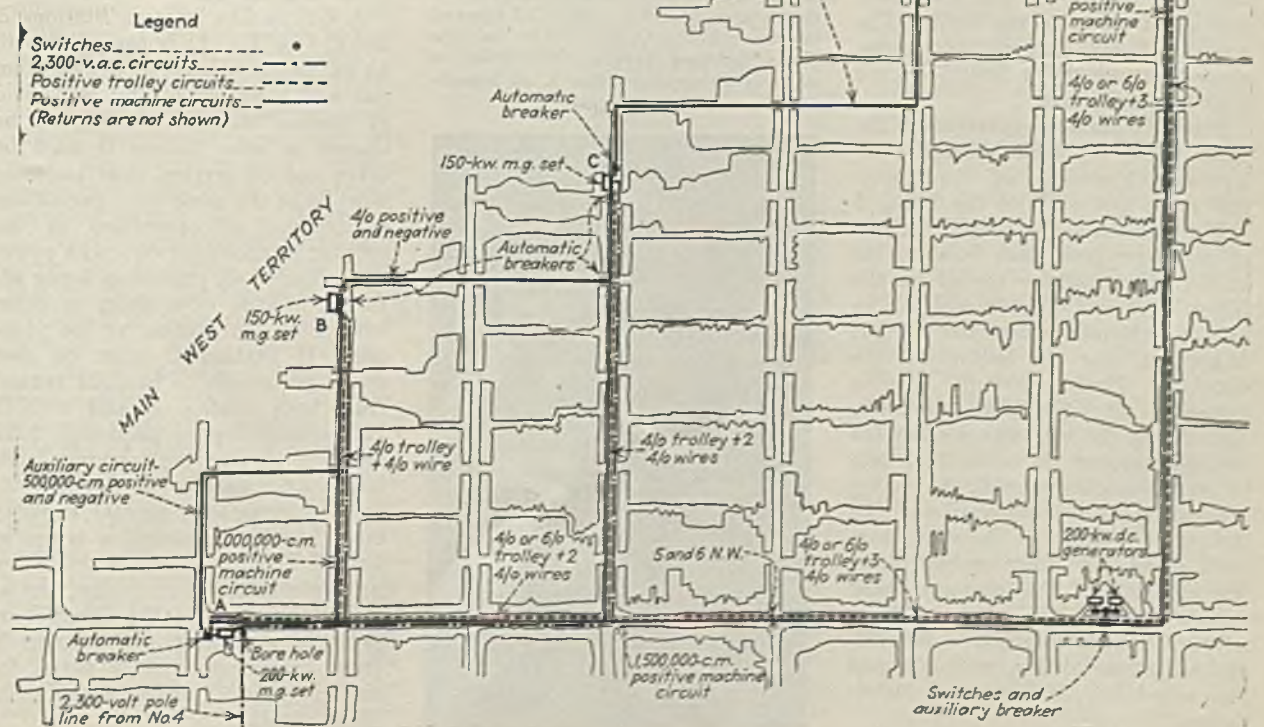

though this section is two miles from the generators on the surface and over a mile from the nearest underground substation. All the d.c. units at the mine are tied together, in accordance with the usual practice—in this case through the machine circuits—and provision is made for isolating either half of the system for checking in case of trouble. Also separate machine and haulage circuits are employed, which permits testing haulage circuits separately, in addition to other advantages (see below). Individual underground substations may be cut out of the system when desired; this, of course, only when a station goes down, in which case its load is taken over by the others.

Copper Used Generously

Location of the d.c. generating units and the substations at No. 3 are indicated in Fig. 1, which also shows the major d.c. circuits. As noted above, a.c. power to operate the three substations is brought in by pole line and borehole from No. 4 mine. From the d.c. generators on the surface at the hoisting shaft the main haulage to the 1 N.E. section is served by a 4/0 or 6/0 trolley line paralleled by three 4/0 round wires to 19E, giving a total of approximately 850,000 circ.mils of copper in the positive circuit. From 19E inside, the circuit consists of the trolley and two 4/0 wires. Face equipment in 1 N.E. is served by a separate circuit 1,000,000 circ.mils in size to 19E, with 500,000-circ.mil lines from that point on in to the inside. The common track return is supplemented to 19E by a 500,000-cir.mil stranded feeder line.

From the surface generators to the Main West, the main-haulage positive circuit consists of the trolley and three 4/0 wires to the 5 and 6 N.W., with the trolley and either two or one wires from that point to the inside. The machine circuit on the Main West is 1,500,000 circ.mils in size and extends to near the 200-kw. substation near the bottom of the borehole. Branch circuits have a capacity of 1,000,000 circ.mils. Switches at the substations allow the motor-generator set to be tied into either the machine circuit, the trolley circuit or both. Contrariwise, the two circuits may be isolated from each other and either or both from the substation. The common track return on the Main West is supplemented at present by a 500,000-circ.mil stranded line, with a second line scheduled for immediate installation.

Breakers with a capacity of 2,000 amp. protect the two generators on the surface. Provision is made on the bottom, however, for switching all circuits to the 1 N.E. and the Main West onto one generator, if desired, in which case the necessary protection is provided by an auxiliary 900-amp. breaker on the bottom, which automatically is cut into the circuit.

As indicated in Fig. 1, the tie between the three motor generator sets and the surface generators is completed by 500,000-circ.mil positive and return lines to the end of the machine circuit in 1 N.E. territory. Automatic reclosing circuit breakers in each end of the tie serve the purpose of isolating the tie line in case of trouble. These breakers are arranged to close from one side only as long as power is on that side alone, with closing on the tie line side only when power is on and the contacts have closed on the opposite sides of both breakers. This arrangement facilitates checking the condition of the machine circuits when starting operation in the morning. The machine system always is cut in two at the end of the shift. Next morning, a switch on the shaft bottom is closed to energize one side of the system and see if the breaker will kick out. Then, a second switch is closed to energize the other side, and if the breaker stays in, the system is clear. As the main-haulage circuits are separate, or can be made so, these

Top of borehole in surface substation at No. 4 mine, showing method of suspending the cables. At the left is the automatic reclosing breaker, installation of which is standard practice in all Superior substations.

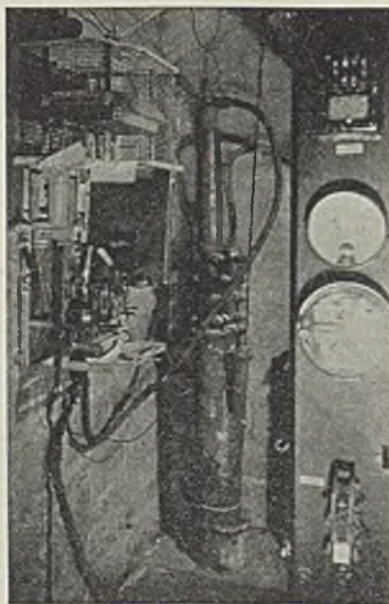

also may be tested individually. Separation of the haulage and machine circuits also has the added advantage that in case a.c. supply from No. 4 fails or the machine circuit goes out, the haulage may be continued to clear the roads to the working sections.

Automatic reclosing breakers originally were used to sectionalize working territories in the Superior mines, and this still is the practice at certain operations. With the advent of mechanization, however, the tendency has been toward the use of this type of equipment in tie lines only, as outlined above. In addition, every substation is equipped with a breaker of this type, regardless of whether automatic or manual controls are employed. In this capacity, the automatic breakers serve to back up the regular station breakers and in the case of manual stations have the effect of rendering them practically automatic on the d.c. side.

Breakers Cut Out Substations

Automatic breakers plus switches also are employed to cut substations out of the circuit in case they go down. At No. 3 mine, for example, 500,000-circ.mil positive and return lines are run north and east from Station A (Fig. 1) to connect with the 1,000,000-circ.mil machine line and return to Station B. A switch at the junction permits power to be brought around from Station B to help out the Main West machine circuit in case it is necessary to shut down Station A.

A 4/0 tie line between Stations B and C (see Fig. 1) is equipped with an automatic breaker at the junction end and a switch at the other end at Station B. The switch can be opened in case Station B must be taken out of service, thus isolating B while at the same time permitting continuance of operations in the working territory between with power from Station C, protection being afforded in case of a short or other trouble by the breaker at the junction. If Station C must be shut down, power can be brought around from both Station B and 1 N.E. This system assures maximum flexibility in serving the working territories and enables a territory to operate at at least partial capacity even though the substation is out of service. This, of course, is not a new principle in d.c. distribution, but at the Superior mines the circuits are arranged so that power brought in from outside territories takes the shortest possible route to the point of application.

PROPELLER FANS

+ Promote Safety and Cut Ventilating Cost When Installed on Shaft Bottoms

By **RAYMOND MANCHA**

*Manager, Ventilation Division
Jeffrey Manufacturing Co.
Columbus, Ohio*

ADDITIONAL safety, reduced power, quietness of operation, and economy and ease of installation are reasons why shaft-bottom propeller-type mine fans are desirable at mines already equipped with an independent surface fan. Under this condition, the shaft-bottom fan, or fans, furnish the daily mine ventilation, leaving the surface fan idle but ready for emergency operation.

The shaft-bottom propeller fan should be accessibly located on the aircourse, preferably at a point between the air-shaft bottom and the first crosscut. This eliminates all possibility of the presence of recirculated air resulting from leaky stoppings. Provision should be made to insure ventilating the electric motor with fresh intake air, as is done in the case of motors driving underground pumps, motor-generator sets, etc. Fig. 1 illustrates practical methods of installation. Electrically actuated signals can be located in the engine room on the surface to show the operation of the shaft-bottom fan. Similar methods are employed to show the operation of surface fans.

If the surface fan is located at a single-compartment downcast or upcast air shaft, the explosion doors over the air shaft should be propped open so as to afford the air the easiest possible access to or from the air shaft. If the air shaft is of the multi-compartment type equipped with a curtain wall separating the intake air from return air, the explosion doors should be left closed, and, if the surface fan is of the centrifugal type, the doors at the rear of the fan should be propped open instead. Thus, the tendency

for discharged return air to reenter the mine will be no greater with the shaft-bottom fan than with the surface fan.

Considering safety first, it is obvious that the shaft-bottom fan will actually be an independent, additional means of ventilating the mine, installed so as to leave the original



Raymond Mancha

surface fan and drive intact and ready for immediate operation if desired. Two independent systems are more reliable than one. A surface fan can be disabled by various means. In the case of an electrical storm there is the possibility of lightning striking the fan motor, motor house or power line. However, with the fan located at the shaft bottom, only the surface power line is vulnerable.

Should a severe mine explosion occur in the vicinity of the air shaft, the shaft-bottom fan probably would be wrecked. However, there is little likelihood of damage to the surface fan, which would be practically isolated from the mine because of the open explosion doors or rear fan doors. Consequently, the surface fan would be ready for immediate operation. On the other hand, an operating surface fan relies completely for protection upon explosion doors that may fail because of inertia, rusty hinges, etc., resulting in fan destruction at a time when the fan is most needed.

Secondly, considering power reduction, it will be seen that the shaft-bottom propeller fan offers economies out of all proportion to the increased mechanical efficiency of this improved-type fan.

When a mine is ventilated by a surface fan at a multi-compartment air shaft, there is likely to be a large amount of leakage air passing through the curtain wall separating the return air from the intake air. Varying temperature differences between the two sides of the curtain wall together with excessive porosity of certain common construction materials, make leakage excessive, since the entire curtain wall is subjected to a pressure differential practically equal to the mine pressure. Consequently, a surface fan usually must handle an air quantity considerably in excess of the underground air actually ventilating the mine. This excess is sometimes as much as 30 per cent of the underground return

air, but to repair a curtain wall is both costly and temporary.

Operation of the shaft-bottom fan automatically makes it possible for the mine fan to ventilate the mine while handling the underground mine air volume only. The pressure differential across the curtain wall is greatly reduced, resulting in reduced curtain-wall leakage and consequently a reduction of shaft-pressure losses. Since the power required for mine ventilation varies directly as the product of the air volume at the fan and ventilating pressure across the mine, it follows that a very considerable reduction in power may be expected with the shaft-bottom fan installed at a mine with a multi-compartment air shaft.

Recirculation Is Slight

It is true that operating a shaft-bottom fan at a multi-compartment air shaft results in slight recirculation due to remaining curtain-wall leakage. That this is small and can be disregarded is best illustrated by considering an actual example. Consider the case of a mine ventilated by a surface fan at a two-compartment air shaft with curtain wall leakage amounting to 30 per cent of the return air as measured at the foot of the upcast air shaft. The normal methane content of this return air is 0.50 per cent by volume. The curtain wall is subjected to static pressure differentials of a 5.00-in. water gage at the top and a 4.50-in. water gage at the bottom. In this case without attempting any curtain-wall repair, and when duplicating the original underground return air volume, operation of a shaft-bottom fan will result in a return-air methane content of but 0.53 per cent, which is substantially the same as the original 0.50 per cent. The example selected is more severe than is usually encountered, so one can safely disregard curtain-wall recirculation.

In the case of a mine with major splits branching off at the bottom of the air shaft, it usually is necessary to regulate all splits except the "free" split to prevent excessive ventilation of the remaining splits with accompanying power waste. With a surface fan ventilating the mine, the entire volume of mine air must be passed against the pressure required to ventilate the "free" split, thereby resulting in an unnecessary waste of power.

By placing shaft-bottom propeller fans on each major split, the above mentioned regulation can be elimi-

nated and the individual fan speed selected so as to meet the natural pressure requirements for each split. Consequently, the air required by each split can be passed against the natural resistance of the split without also having to overcome artificial resistance in the form of regulation. Here again the shaft-bottom fan makes possible large power reductions which are not available with a surface fan.

At a well-known 3,000-ton mine with two-compartment air shaft and underground regulation, the surface centrifugal fan formerly ventilated the mine with an underground air volume of 117,300 c.f.m., requiring a motor power input of 111.8 kw. Following the installation of two inexpensive shaft-bottom propeller fans, with fan efficiency about equal to that of the surface fan, the underground air volume was increased to 123,600 c.f.m., requiring a total power input of but 68.3 kw. to both motors. This entire saving was the result of the elimination of curtain-wall leakage and underground regulation.

Fig. 1—Alternative methods of installing propeller fans underground.

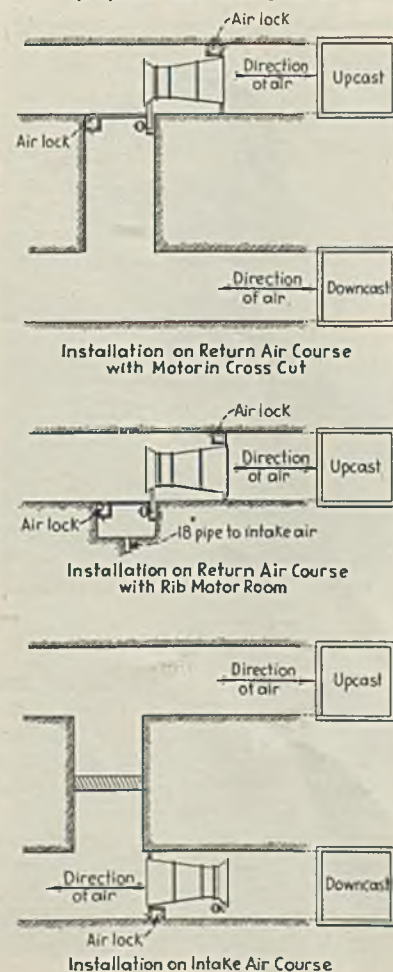

When the air shaft is so located that quiet fan operation is essential and the mine ventilating pressure is high, the noise made by the quietest available propeller fan may prove objectionable if the fan is installed on the surface. However, with the shaft-bottom propeller fan this objection is eliminated. Operation of the noisiest shaft-bottom propeller fan is barely audible either at the surface or on the haulage road below ground.

Economy and ease of installation are important attributes of the shaft-bottom propeller mine fan. By virtue of the fan's location all customary auxiliary steel work is eliminated such as the air-shaft hood, duct work, motor house, etc.

Having to handle the underground mine air only, at a mine with a multi-compartment air shaft the shaft-bottom fan, or fans, can be of less capacity than a surface fan which also must handle curtain-wall leakage air. This results in less expensive fans being required for shaft-bottom installation than are required for surface installation, unless additional money is spent to repair the leaky curtain wall.

No Interruption of Operation

Shaft-bottom fans are installed without interrupting operation of the mine. To install a replacement surface fan it usually is necessary first to remove the old fan to provide room for the new. This is expensive and necessitates the suspension of mine operation for several days. Such suspension results in lost tonnage and is not desirable in gassy mines because of the explosion hazard. In this respect shaft-bottom fans are not only cheaper and more convenient to install but may be the only type of installation possible at a gassy mine.

An additional safety feature of the shaft-bottom propeller fan results from merits already discussed, such as reduced power, quietness of operation, and economy and ease of operation. Any or all of these merits may make installation of an efficient shaft-bottom propeller fan feasible, even when a new surface installation is too costly or is impractical.

The lower power requirements of the shaft-bottom fan will encourage the use of an increased air volume in ventilating the mine, since a ventilation increase is possible for the same power previously required by the surface fan. Such encouragement is a step in the direction of greater safety.

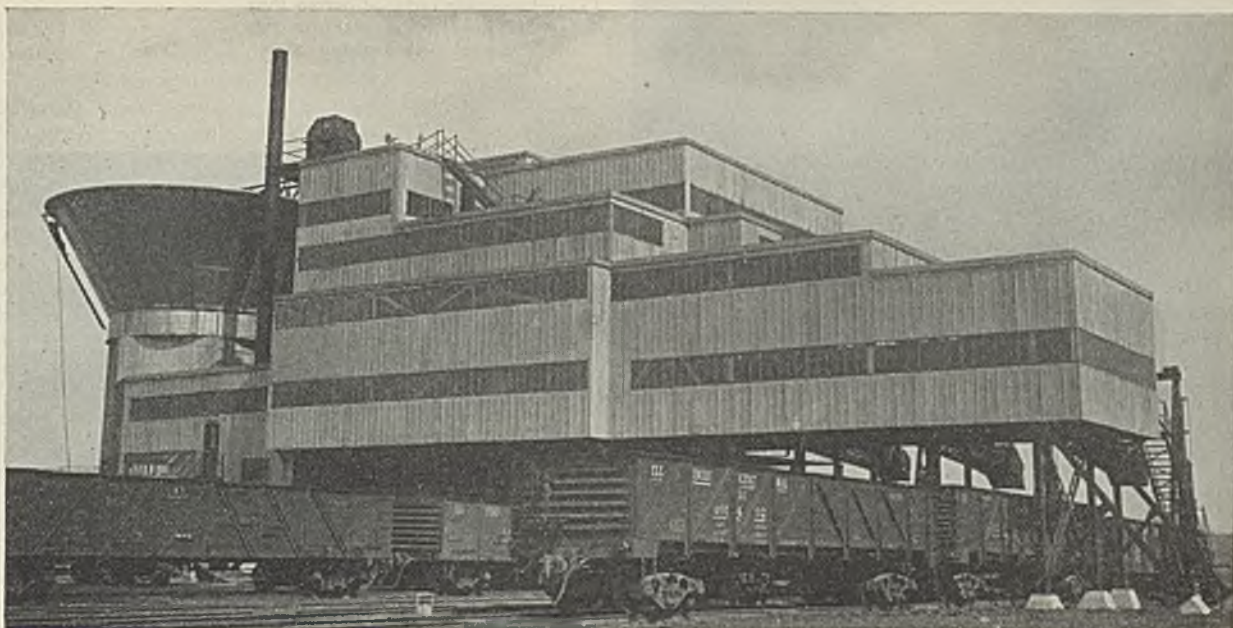

Squared forms and long rows of window lights give the new Sentry preparation plant a distinctive outward appearance

100-PER-CENT FLEXIBILITY + Attained With Extremely Simple Flowsheet At Sentry's Modernistic Preparation Plant

By IVAN A. GIVEN

Associate Editor, Coal Age

FOR THE FIRST major stripping operation in Kentucky in late years, the Sentry Coal Mining Co., a member of the Sinclair stripping group, chose what is described as "America's first modernistic preparation plant" to clean, size and otherwise prepare its output. With a rated capacity of 500 tons per hour and including two automatic washers with a total capacity of 400 tons of 6x2½ and 2½x0-in. coal per hour, the Sentry plant, seven miles west of Madisonville, Ky., has loaded as much as 12,543 tons in three consecutive shifts, of which 80 per cent was washed and the remainder represented 6-in. lump. Reject percentage at Sentry runs about 10 per cent, excluding slurry.

Six primary sizes and combinations, as well as crushed coal, are shipped under the "Sentry 14" and "Stray Seam" trade names. These usually are: 6-in. lump 6x3-in egg,

3x2-in. stove, 2x1¼-in. nut, 1¼x½-in. pea and ¼-in. screenings. Combinations of these sizes, including 2- and 1¼-in. stoker, and crushed coal are in frequent demand, however, so that a washed coal crusher and a mixing conveyor often are in service. Scraper-type rescreening loading booms are used to load the three larger sizes, with two-way chutes to permit car changing without stopping the plant for the other three. Provision is made for treating all sizes to render them dustless by the "Waxolizing" process.

The Sentry operation is the outgrowth of the acquisition of the former Leslie Larsen & Co. stripping by the Sinclair interests in 1937. The seam recovered is the Kentucky No. 14, averaging 84¼ in. in thickness, excluding a layer of bottom coal which is left in place. Overburden thickness ranges from 15 to 55 ft., and averages 33.44 ft. Stripping is done by a Marion 5320 elec-

tric shovel with 12½-cu.yd. aluminum dipper, and the coal is loaded by a Bucyrus-Erie 50B shovel with 3½-cu. yd. "Man-Ten" bucket. A 381 dragline also is used for extra loading, if desired. Coal is hauled from the pit to the preparation plant in five 15-ton Sanford-Day drop-bottom semi-trailers pulled by TF "Autocar" tractors.

A leading exponent of the washing method of preparing coal, the Sinclair organization replaced the original Larsen tippie, using such material as would fit into the new, with the plant herein described, which was designed and built by the McNally-Pittsburg Manufacturing Corporation. From the standpoint of outward aspects, simplicity together with distinctive appearance were the keynotes, obtained by the use of

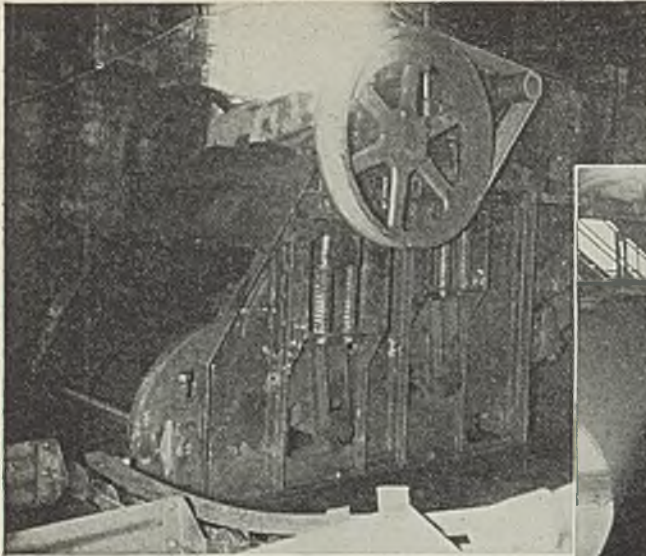

Large lumps are reduced before they enter the preparation plant in this vertical pick breaker

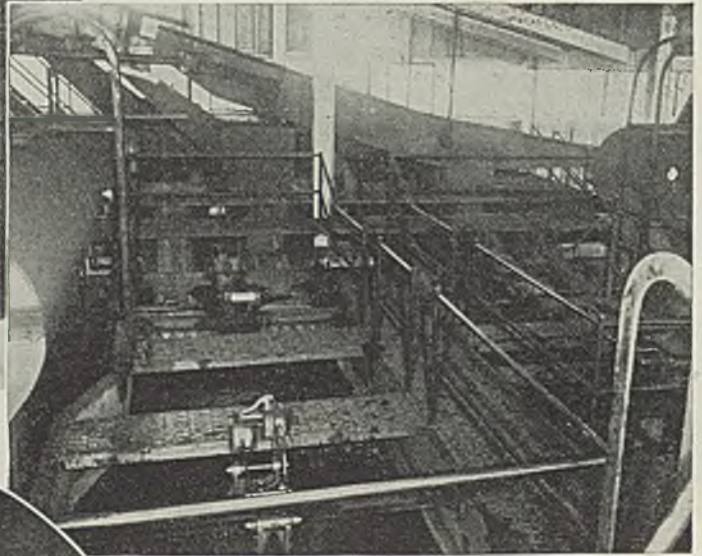

Washing floor at Sentry, with the mine-run shakers in the background. Drop chutes and launders bring the coal to the washers. This view also shows a typical installation of handrails.

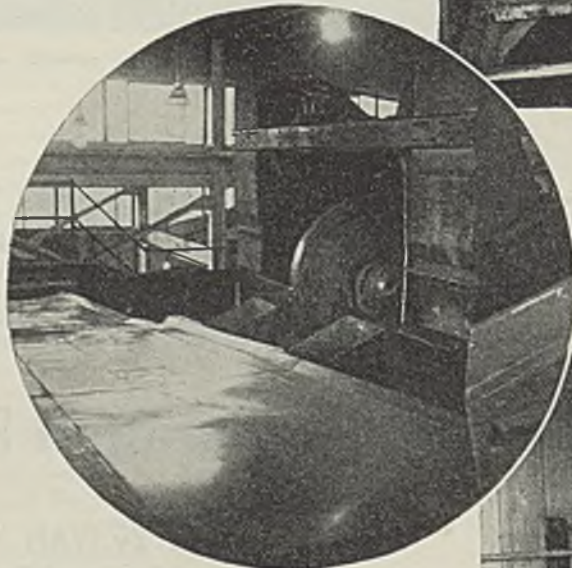

Six-inch lump is cleaned on this two-section shaking picking table. At the right are the reject elevators of the 6x2½-in. washer.

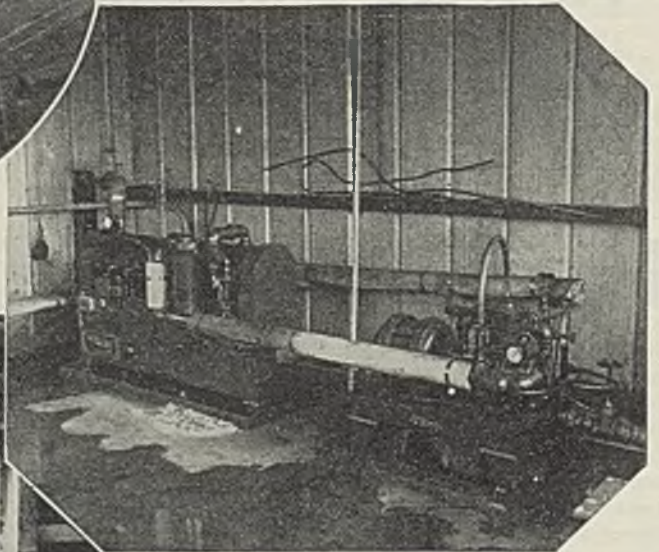

One of the two heating units used in heating the coal-treating fluid prior to application at Sentry.

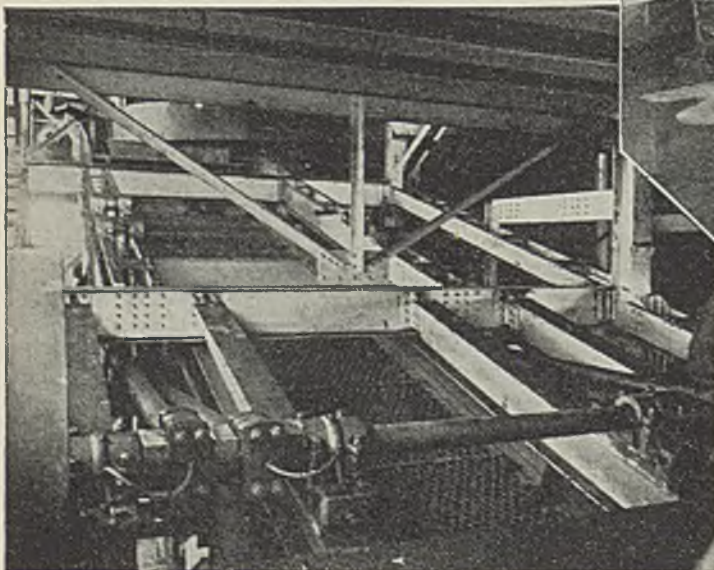

Part of the washed-coal classifying screen. When this photo was taken, the screen had been fitted with special plates for special screening.

squared forms and long rows of windows along the various floor levels.

From the construction standpoint, the goals were convenience and efficiency in equipment arrangement, adequate space around units for good lighting and easy access, and up-to-date guarding and other methods of making the plant as safe and as fire-proof as possible. From the standpoint of flow of coal through the plant, arrangements were made for gravity to do the work wherever possible, thus reducing the number of conveyors and elevators. In fact, excluding loading booms, the plant has only seven conveyors and one elevator in service. The result is an extremely simple flowsheet, although the plant can perform all of the functions normally asked of a modern preparation unit.

Coal from the pit is dumped into a 75-ton electric-welded hopper, from which it is moved out onto the main conveyor feeding the plant by a reciprocating feeder suspended from the bottom of the hopper. The feeder (Table I) is equipped with both a variable-stroke eccentric and a Reeves variable-speed gear for adjusting the feeding rate. To accomplish this purpose a tachometer indicator calibrated in tons per hour is placed on the washing floor so that the operator can make any changes warranted by the nature of the raw feed or other conditions.

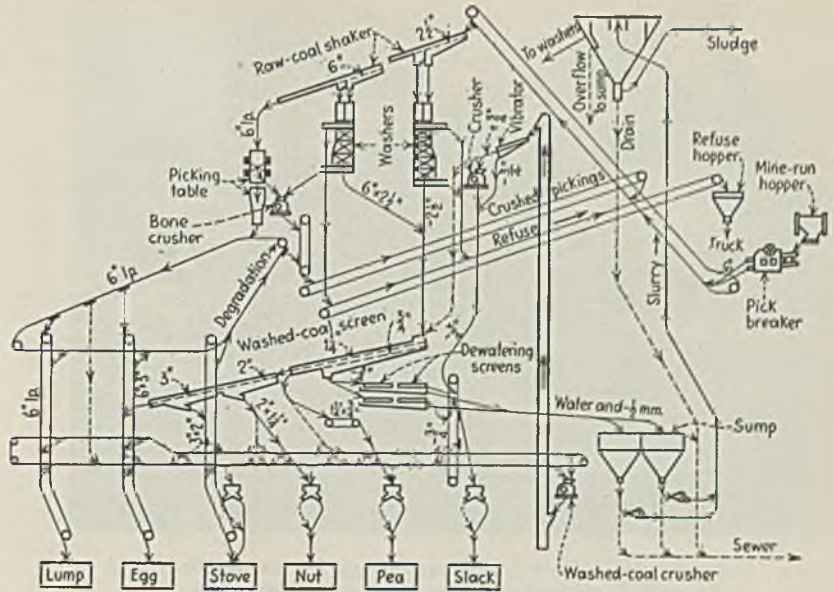

Fig. 1—Flow diagram, Sentry preparation plant

The feeder is followed by a 60-in. Type B McNally-Norton vertical pick breaker for breaking plus 6-in. coal to 6 or 7 in. before passing it to the main chain-and-flight conveyor feeding the preparation plant. This conveyor is inclined 35 deg., and the chain-and-flight type was chosen so that it could be placed on a greater inclination and thus avoid a much greater horizontal distance from hopper to plant. The breaker

is arranged so that additional picks may be installed to break the coal to 3 in. The screen section is provided with bar grizzlies at the upper end for bypassing minus 6-in. material, with arrangements for adding extra bars for bypassing minus 3-in. material. Bypassed coal joins the broken material on the main conveyor.

Raw coal at Sentry is separated into plus 6-, 6x2½- and 2½x0-in. fractions on two 6-ft.-wide all-steel shakers suspended by forged-steel brass-bushed hangers. Pitman arms are made of 4-in. extra-heavy pipe. The same construction is followed in the case of the washed-coal classifying screens, except that shorter hangers are employed. The 6-in. lump off the end of the lower mine-run shaker discharges into a shaking picking table made in two balanced sections, each with single pitman. The sections are supported on ash-board legs. From the table, hand-picked lump coal drops into a lump lowering conveyor of the chain-and-flight type, which carries it to the lump loading boom. Auxiliary gates in the conveyor permit diverting the lump to either the mixing conveyor or to the stove loading boom, as desired.

The lower run of the lowering conveyor is arranged to receive degradation from the three 48-in.-wide scraper-type loading booms for the lump, egg and stove sizes. This degradation is returned to the main raw-coal conveyor via the middlings belt system, as indicated in the flowsheet.

Material picked off the table drops into a 24-in. Jeffrey single-roll

Table I—Motor and Drive Details, Sentry Preparation Plant

Equipment	Motors			Drive
	Number	Type	R.P.M. Hp.	
Reciprocating feeder, 5x8 ft., 6- to 10-in. stroke, 48.2 to 12 r.p.m.	1	K*	1,750 10	V-belt ¹ to variable-speed gear ² to gears
Pick breaker	1	KT*	1,160 25	V-belts ¹
Main raw-coal conv., 48x12 in., 400 t.p.h. at 100 f.p.m.	1	KT*	1,175 75	Roller chain and spur gears
Raw-coal shakers, 6 ft. wide, one screening deck: upper, 20 ft. long; lower, 30 ft. long, 100 r.p.m.	1	**	870 15	V-belts ¹
Two-section shaking picking table, 17 and 18 ft. long, 54 in. wide, 150 r.p.m.	1	**	1,160 5	V-belts ¹
Lump-lowering conv., 30-in., 2-in. sq. tubing flights, 60 t.p.h. at 70 f.p.m.	1	**	1,160 7½	V-belts ¹ and spur gears
Washers	2	K-gear*	114 5	Roller chains
Washer blower	1	KF*	3,580 50	Direct
Washer blower	1	KF*	3,540 40	Direct
Middlings crusher	1	K*	1,170 25	Spur gears
Middlings cross conv., 24-in. belt	1	**	1,160 3	V-belts ¹ and spur gears
Middlings elevating conv. to main conv., 24-in. belt, 250 f.p.m.	1	**	1,160 5	V-belts ¹ and spur gears
Refuse belt, 24-in., 250 f.p.m.	1	**	1,160 5	V-belts ¹ and spur gears
Washed-coal classifying screen, 26- and 31-ft. sections, 4-in. stroke, 150 r.p.m. (see also text)	1	**	880 15	V-belts ¹
Dewatering screens, 6x20 ft., 350 r.p.m.	1	K*	1,160 10	V-belts ¹
¾-in. collecting conv., 125 f.p.m.	1	K-gear*	150 5	Roller chain
1½x¾-in. conv., 24-in. belt, 200 f.p.m.	1	K-gear*	68 5	Roller chain
Loading booms, 48 in. wide	1	K*	1,160 20	V-belts ¹ to shaft
Boom hoists, 3 tons	3	C-32†	1,530 5	
Mixing conv., 500 t.p.h. at 100 f.p.m.	1	**	1,160 50	V-belts ¹ and spur gears
Washed-coal crusher	1	‡	1,155 60	V-belts ¹
Crushed-coal elev., 30x12-in. buckets, 100 f.p.m.	1	**	1,155 25	V-belts ¹ and spur gears
Crushed-coal vibrating screen	1	**	1,155 5	V-belts ¹
Override pulverizer	1	MT*	695 50	Direct
Gate valve, fresh-water line	1	K-gear*	2	Spur gears
Slurry pumps	2	KT*	1,180 75	Direct
Fresh-water pumps	2	K*	1,170 25	V-belts ¹
Unit heaters	6	P‡	1,140 1.6	Direct
Hot-oil pump	1	K*	1,725 ½	Direct
Hot-oil pump	1	K*	1,140 2	Direct

* General Electric. ** Westinghouse. † Shepard-Niles. ‡ Gates "Vuleco" and Goodyear "Emerald Cord." § Emerson. ¶ Reeves.

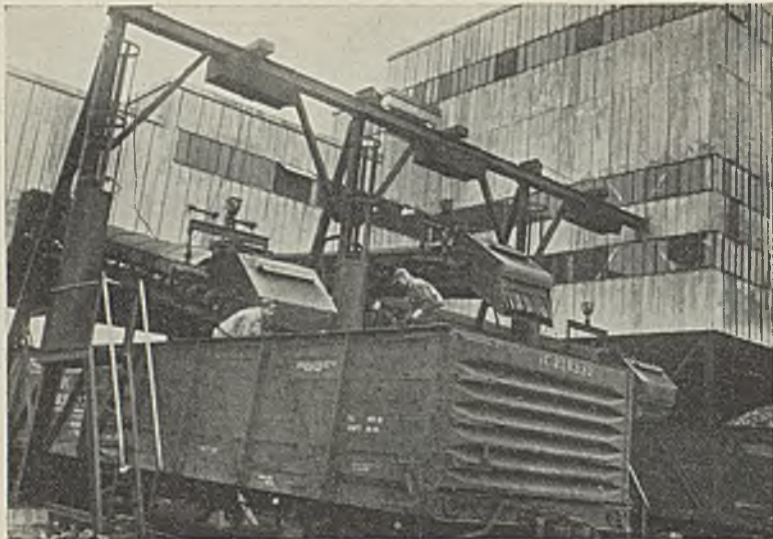

Loading and inspection at Sentry, showing the type of treating hoods used on the ends of the loading booms for lump, egg and stove

crusher, where it is reduced to $3\frac{1}{2}$ to 4 in., or 2 in., depending upon screenings demand, and is discharged to the middlings belt conveyor system for return to the preparation circuit for re-treatment to recover coal values. The middlings-belt system gets its name from the fact that it originally was designed to handle only this product, with pure refuse from the table going to a refuse belt (24 in. wide, 4-ply 28-oz. duck U. S. Rubber belt carried on McNally-Pittsburg rolls fitted with New Departure "N-D-Seal" ball bearings). Efficiency considerations, however, dictated running all material picked off the table to the crusher.

Two Washers Clean Coal

Coal 6x $2\frac{1}{2}$ -in. size from the raw-coal shakers is washed in a McNally-Norton automatic washer with three compartments. One compartment is the primary and the other two are the secondaries. Separately adjustable automatic reject controls regulate the discharge of primary and secondary refuse, respectively. A second similar washer, but with two primary and three secondary compartments, cleans 2 $\frac{1}{2}$ x0-in. coal. Carrying out the gravity-flow principle, the washers receive coal from the shakers via drop chutes and launders, as shown in an accompanying illustration.

Two launders, each with drop chute, serve each washer. One drop chute in each case takes coal from one side of the shaker, while the other, placed far enough below to allow positioning the launders side by side, takes coal from the other half of the shaker. Launders are fit-

ted with pre-wetting nozzles and also are equipped with Norton start-stop controls actuated by vanes in the launders for stopping the washing units when the coal ceases to flow and starting them when it resumes, thus insuring the best bed conditions in the washers.

Refuse from the primary washing compartment of the 6x $2\frac{1}{2}$ -in. washing unit and from both compartments of the 2 $\frac{1}{2}$ x0-in. washer is discharged directly into the refuse conveyor, which deposits it in a 30-ton steel bin, from which it is hauled away to the pit or other disposal site in trucks. Refuse from the secondary washing compartment of the 6x $2\frac{1}{2}$ -in. washer drops into the middlings crusher and from there is returned to the preparation circuit, as outlined above.

Two electric-welded launders carry the washed coal and water from both washers to the washed-coal classifying screen, made in two balanced sections. The upper deck of the upper section, .6 ft. wide and about 30 ft. long, normally is fitted with 4 ft. of $\frac{1}{2}$ -in. round perforated plate and 16 ft. of $1\frac{1}{2}$ -in. round plate, with 16 ft. of $\frac{3}{4}$ -in. round on the lower deck. Water and fine coal through the lower deck fall onto a carrying deck. The lower section of the classifying screen comprises a single screening deck with 12 ft. of 2-in. round and 8-ft. of 3-in. round perforations. With this set-up, the classifying screen produces 6x3-in. egg, 3x2-in. stove, 2x $1\frac{1}{2}$ -in. nut, $1\frac{1}{2}$ x $1\frac{1}{2}$ -in. pea and a minus $\frac{3}{4}$ -in. resultant.

The minus $\frac{3}{4}$ -in. coal flows with the water to two high-speed (350-r.p.m.) dewatering screens. The launder pre-

ceding the screens is fitted with $\frac{1}{2}$ -mm. bronze wedge wire at the delivery end to unload part of the water and slurry before the coal goes onto the screens. Each screen provides approximately 120 sq.ft. of $\frac{1}{2}$ -mm. bronze wedge-wire screening surface. Dewatered coal goes to a collecting conveyor discharging either to the screenings track or the mixing conveyor.

Water and minus $\frac{1}{2}$ -mm. slurry run to a sump equipped with two conical bottoms to serve two McNally-Pittsburg 10x10-in. centrifugal pumps with wearing parts of "Ni-Hard" iron. One or both pumps may be used, as desired, to lift the slurry and water to a 40-ft.-diameter settling cone. Clarified water from the cone flows by gravity to the washers. Extra water is returned to the pump sump, the overflow from the sump in turn going to waste. Fresh water is introduced into the plant through sprays over the classifying and dewatering screens, and is supplied by two triplex pumps with a capacity of 500 g.p.m. each. Either one or both may be operated, as necessary, depending on plant requirements.

Scraper Mixing Conveyor Used

Combinations of sizes are made at Sentry in a scraper-type mixing conveyor with $\frac{1}{2}$ x12x36-in. flights on 36-in. centers. The lower run is fitted with rack-and-pinion gates over three tracks, while the top run is arranged to receive any or all of the sizes under 3 in., making it possible to load mine-run on the stove-coal track or minus 6-in. on this track and lump on the regular track. Also, 3-in. minus may be loaded on the nut track and 2-in. minus on the pea track. As all sizes from 2 in. down may be run into either the top or bottom strand of the mixing conveyor, which is reversible, it is possible to crush all or a part of the coal from 3 down to $1\frac{1}{4}$ in. while continuing to load the smaller sizes. Furthermore, any size may be robbed out and loaded while making mine-run mixtures.

All coal over $1\frac{1}{4}$ -in., or any size in that range, may be crushed in a McNally-Pittsburg 24x48-in. "Multiplex" single-roll unit. Coal is delivered to the crusher on either the top or the bottom run of the mixing conveyor, and the crushed product is discharged into an elevator which delivers the coal to a 4x8-ft. Link-Belt vibrating screen. This screen separates the feed into plus and minus $\frac{1}{2}$ -in. fractions, the smaller going to the collecting conveyor following the dewatering screens. The

larger fraction originally was run to the washed-coal classifying screen, and still can be handled in that way. However, it was found that this practice builds up a large circulating load of coal, and consequently a Williams pulverizer has been installed to break down the oversize from the vibrating screen.

Lump, egg and stove, as indicated above, are loaded over 48-in.-wide scraper-type booms with degradation screens in the upper runs of the horizontal sections. Three-ton Shepard-Niles hoists raise and lower the booms in loading. The other three sizes made at Sentry are loaded through two-way chutes with flop gates for use when changing cars. A two-way chute also is provided for loading over the stove track, if desired—primarily in the case of mixtures.

Including the fresh-water pumps, the Sentry preparation plant is operated by 40 motors ranging from $\frac{1}{2}$ to 75 hp. in size. All motors operate on 440 volts a.c., and linestarters are used exclusively. All circuits are protected either by fuses or air-break switches. Rigid conduit, with some Bx conduit, is used throughout. In addition to 1,125 linear ft. of

windows, illumination is provided by 60 drops with vapor-proof sockets. Drops are suspended from shock-absorber self-aligning fittings, using $\frac{1}{2}$ -in. conduit.

Above ground level, the main conveyor gallery is provided with a wooden stairway on both sides of the conveyor. In the main building, the first floor above the track is made of concrete, with all the upper floors of subway grating, with the exception of the picker's stations and one or two other points. All stairways, areaways and other dangerous points are protected with 1 $\frac{1}{4}$ -in. steel-tubing handrails, installed by electric welding. V-belts, chains and other drive parts are inclosed in sheet-metal guards. Eccentrics are lubricated through "Alemite Zerk" fittings.

The structure is covered with 24-gage siding. All roof lines are flat, and roofs are built up on a base of one ply of 1-in. shiplap on steel purlins, followed three plies of felt and a covering of asphalt and gravel. Six unit heaters supplied with steam from a Keewanee hand-fired boiler in the settling-cone housing keep the structure warm during cold periods.

All sizes shipped from the Sentry

preparation plant can be "Waxolized" to allay dust. Lump, egg and stove are treated in hoods on the ends of the loading booms, as shown in an accompanying photograph, while the other three sizes are treated in chutes at convenient points. In any event, however, the coal is sprayed while it is in the air to insure a better and more even coating, even in the case of 6-in. lump. A Viking dual heating system raises the temperature of the "Waxol" treating fluid prior to spraying. Average consumption of treating fluid at Sentry is 3 qt. per ton, and ranges from 2 qt. per ton of lump to 5 qt. per ton of stoker coal.

In addition to being free from dust, "Waxolized Sentry 14" coal also is less subject to degradation, handles easier, is less likely to lose or absorb moisture in transit and is slightly better from the standpoint of burning qualities due to slower release of volatile matter because drying out is checked. Other claims for "Waxolizing" are reduced discoloration, less tendency to depart from the original mixture of coarse and fine coal in stoker sizes and elimination of clogging, binding or arching of stoker coal in hoppers.

VALIER SUPPLIES SYSTEM

+ Keeps Materials at Points of Need

With Minimum Labor and Record Keeping

CONSIDERING degree of mechanization and production per day, a relatively simple system of requisitioning, ordering, receiving, storing and issuing supplies and materials, including repair parts, is employed at the Valier (Ill.) mine of the Valier Coal Co. In fact, all ordering is done and all records in connection with the above activities are kept by one man, with occasional assistance from time to time during the year.

One small form is all that is used to secure parts or other materials or supplies from stock, and supply disbursement is arranged so that, as

far as possible, parts frequently needed in repairing equipment, particularly loading machines, are kept near or in the working section so that delays chargeable to waiting for parts are cut to a minimum. To assure that these parts always will be available, repairmen are trained to ask for a new piece when the supply on hand is exhausted and to keep on asking until it is received. By introducing the element of personal responsibility, paper work and record keeping are reduced and buck-passing is eliminated. However, one element in making this system a success is the fact that

practically all repairmen are old timers trained to discharge automatically their function of keeping parts and materials on hand.

Under the Valier system, the maintenance of equipment is separated roughly into three divisions, which also determine in the main the routes followed by parts and supplies to the point of consumption. Repairs of a minor to a semi-major nature which do not require extensive dismantling of equipment are made in the working section. On loading machines, for example, guide bars, curve bars crank disks, caterpillar drive shafts, hydraulic

jacks, etc., are changed in the section, which means that these parts, with the exception of the large and expensive disks, are kept in the section or at the nearest parting. On cutting machines, about the only large-scale work done at the face is changing bit clutches. Very little heavy work is done on locomotives back in the mine, the custom being to send in a spare from the bottom or borrow one from the nearest loader being served by two.

Heavy repairs other than those listed above are made in an underground shop on the bottom, although work in this shop in most cases is more properly assembling, as actual repair work, such as rewinding an armature or rebuilding a loading-machine head, along with all general overhauling of underground machinery, is done in the surface shops. Consequently, the underground shop is concerned primarily with taking out broken or worn parts and replacing them with rebuilt or overhauled parts from the surface shops or with new parts from stock. However, this is not to be taken as indicating that what might be called true repair work is not done in the underground shop, such as, for example, welding a cracked frame.

Storeroom Built on Bottom

In view of the above, it may be seen that a substantial quantity of new parts and materials for underground equipment go directly from the warehouse to the surface shops, where they generally are used immediately. Time is not so great a factor in work on the surface. In the underground shop, however, the time element begins to move into the foreground, as here the question is primarily one of fitting up a machine so that it can go back into service as soon as possible. Consequently, this shop is accompanied by a storeroom where a supply of the necessary parts is kept on hand so that they are available instantly. This storeroom, however, hardly could be called a supply house in the usual sense of the term, because it keeps only the bare minimum of parts and materials on hand necessary for the normal run of assembly work, obtaining new supplies as these are used up from the regular supply house, where the main long-time reserve is kept. Also, all parts in the underground storeroom in effect have been used, inasmuch as they were requested on the usual form and were changed on operation when sent out from stock. Spare parts assemblies, such as all locomo-

tive armatures, one motor for both loading and cutting machines, etc., also are kept in the underground storeroom or shop. If rebuilt, the parts and supplies likewise are charged out when issued to the surface shop. Thus, all parts and supplies in the underground storeroom represent charges against coal.

The repair parts and supplies in the underground storeroom are under the jurisdiction of the machine boss, who has the duty of seeing that material used is replaced immediately so that he will never find himself short at a critical moment. The machine boss also supplies the needs of the section repairmen, who apply to him for material to keep their own supplies up, although, of course, some materials for repair work may be sent to a working section directly from stock. Normally,

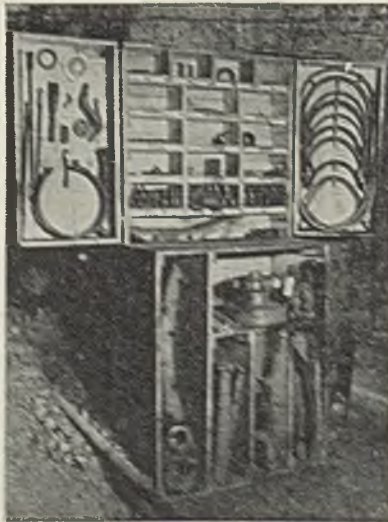

The parts reserve for a number of loading machines and auxiliary equipment—a parting cabinet in Valier mine.

in emergencies, however, the section repairmen look to the machine boss for their materials.

Major underground equipment at Valier, which produces 7,500 tons or more per shift, comprises electric locomotives, including battery units, track-mounted and shortwall cutters, loading machines, track- and post-mounted coal drills, mine cars with solid- or tapered-roller or ball-bearing wheels and certain miscellaneous equipment, such as portable air compressors, etc. All electrical equipment is a.c. with the exception of the locomotives. Distance from the bottom to the working sections varies from $1\frac{1}{2}$ to 2 miles—another incentive for keeping frequently used parts near the face.

A start toward mechanization at Valier was made with the installation of pit-car loaders, or conveyors, in 1928. By the middle of 1929, mechanization with mobile loaders had been completed. From the standpoint of the supplies problem, mechanization resulted in the addition of about 700 items to the parts and supplies list. This includes all tools which, under the hand-loading system, were supplied by the miner. The number of locomotives was increased as another outgrowth of mechanization, with the result that while only a few items were added to the list the quantity rose considerably.

Carry 25 Material Classes

The present system of ordering, receiving and disbursing supplies was put in in 1922 by the storekeeper now in charge, who has jurisdiction over a parts storeroom, two large material buildings, an oil house, a gasoline filling station, a yard for timber and other materials, and explosives and detonator magazines. To facilitate storage and disbursement of supplies, and also so that an eye can be kept on the trend of use of the various types, all parts, materials and supplies are divided into 25 classes, as follows:

1. Building material.
2. Track material.
3. Trolley-line material and parts.
4. Props and lumber.
5. Mining and other machinery parts.
6. Electric-motor and power parts.
7. Telephone and signal parts, wire and electric lighting, miners' lamps.
8. Electric-locomotive parts.
9. Mine-car parts.
10. Steel cables, blocks, wire ropes and sheaves.
11. Pipes and fittings.
12. Hardware.
13. Iron and steel.
14. Belting and clamps and belt rivets.
15. Tools — hand and machine; handles.
16. Brattice and rub cloth and packing.
17. Oils, gas, waste and grease.
18. Sand.
19. Acetylene and oxygen.
20. Explosives.
21. Roll and roller bearings.
22. Special items.
23. Scrap.
24. Miscellaneous.
25. Returnable material.

When issued, parts, material and supplies are charged to "operating

of the superintendent and general manager, after which it goes to the auditor for payment. Before passing to the superintendent and general manager, however, the order number and amount of the invoice are entered in the "Material Received" ledger, while the amount of the invoice and the freight charges, together with the invoice date, are entered in the stock ledger. The material then is in stock, and when the invoice and freight bill are paid the total is charged to the material class. These charges, less disbursements to the proper operating or capital accounts, constitute the auditor's stock balance, against which a physical inventory, made at convenient times, balances.

Issues Recapitulated Daily

Requests for supplies are signed by the foremen or other authorized persons, who specify only the use, quantity of material desired and the type (Fig. 1) and send the form to the storekeeper, who fills in the account or A.F.E. number, price, etc., and issues the supplies. The issue then is charged off in the stock ledger, which then shows the quantity and money value of these particular parts or supply items left on hand. At the end of the day, the parts and supplies issued are recapitulated and distributed among the various materials classes and operating accounts. With this data, daily and cumulative costs per ton are calculated.

From the standpoint of control, the stock ledger is the most important factor in the Valier supply system. In addition to the other

data noted above, the ledger sheets (Fig. 1) also carry, among other things, the section and bin numbers where the material is stored, and serve as an up-to-the-minute running record of the issuance, money cost and reserves of parts and materials. Except for the actual labor of handling supplies and the necessity for a periodic inventory, the supply system, for all practical purposes, can be operated by the use of these ledgers only, as they automatically show, when a withdrawal is made, the amount of that particular material left on hand and thus whether a reorder is necessary. Also, as in the case of cable, it is simple to note the machine to which each is sent and thus by looking back through the sheets to see what the life has been. Furthermore, when the amount expended for a certain item is wanted, such as a certain machine bolt, all that is necessary is to run back through the ledger sheets for the period in question and add up the money cost of those issued. And if it becomes necessary to order an item for which the order amount is small, the ledger sheets for similar material may be consulted so that in case it is about time to reorder others they may be added in to build up the order total.

All materials, parts and supplies are charged to the production for the day they are issued, regardless of the amount of money they represent. Provision also is made for handling returned material, as indicated in Item 25 of the materials classes (see above). From this item the materials are returned to their proper materials classes. The Valier system also includes a scrap class,

and the company also follows the practice of valuing this scrap and crediting it once a month to the proper accounts, rather than waiting until it is sold and then apportioning the lump sum of the proceeds.

For convenience in keeping frequently required parts and materials near the face and also to have a suitable place in which to keep them and thus prevent scattering and possible loss, the Valier management has adopted the plan of installing auxiliary supply bins and cabinets at convenient points in or near the working sections. The cabinets are designed for installation on partings serving a number of sections, and here, under the eye of the parting tender, is kept a supply of the heavier or more costly items, or the smaller items not so frequently in demand. These cabinets serve a number of sections and, as shown in the accompanying illustration, are built so that the top section, in which the lighter items are placed, can be closed. Heavy items, such as curve bars, guide bars, gathering arms, caterpillar shafts, hydraulic jacks, pumps, ropes, etc.—usually one and sometimes more of each—are kept in separate compartments in the bottom.

Fewer Parts Required

When the cabinet idea originally was adopted, a range of items, including a few assemblies, were kept in each. Time showed, however, that many of these either were small and thus could be moved up into the section or were so infrequently used that it was unnecessary to have them always on the ground. Consequently, the content of each cabinet has been substantially reduced.

In addition to the items kept in the cabinets, other bins for smaller and more frequently used items are kept in the various working sections, usually in the face boss' shanty. Such a bin is shown in one of the accompanying illustrations. Sometimes, especially if the parting is somewhat far away or if the sections are close together so that the repairmen can work jointly on stocks of items, some of the parts kept in the parting cabinet may be moved up to the section station. In any event, the rule is to have all the necessary parts for the usual repairs not farther away than the partings, and when a part is used, regardless of whether it is obtained from a parting cabinet or a bin on the section, the rule is that a new one must be ordered immediately and followed up until it is received.

Typical parts reserve carried by a section repairman in the boss' shanty.

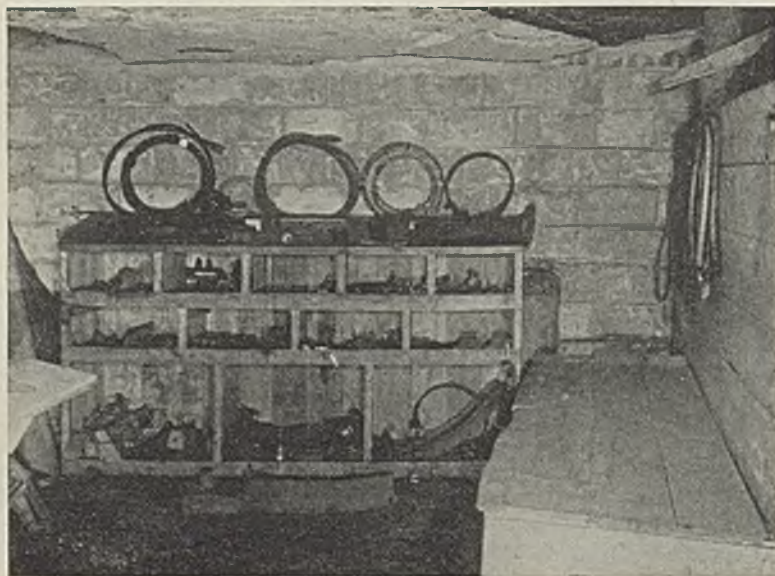

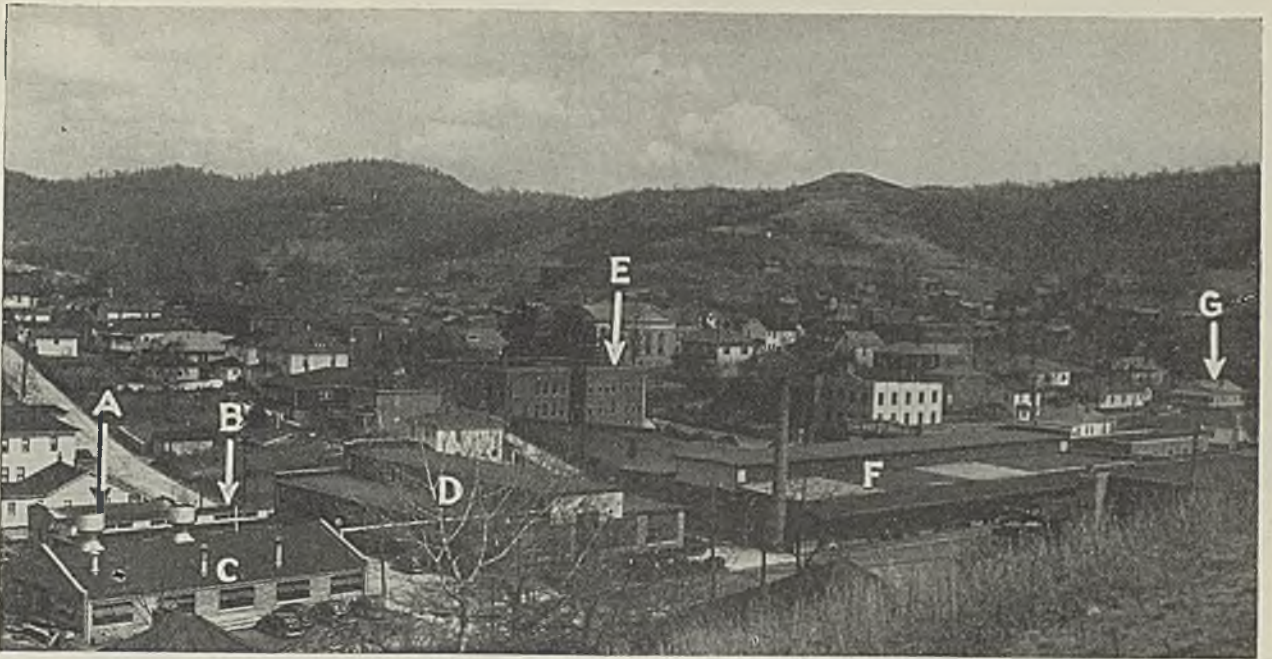

So far as possible, all functions of the New River Co. are now centralized at Mount Hope: A, new mine-rescue station; B, bit-sharpening building; C, new building for foundry work, welding and black-smithing; D, main building of central shop; E, main and operating office; F, warehouse for mine supplies and store stock; G, building recently remodeled for a retail store.

IMPROVED MAINTENANCE + Plus Better Store and Rescue Station Follow Changes at New River Headquarters

By J. H. EDWARDS
Associate Editor, Coal Age

IN ADDITION to central-shop improvements and new methods which have reduced maintenance costs, the Mount Hope, W. Va., operating headquarters of the New River Co. has undergone other changes including the construction of a mine rescue station and the remodeling and fitting of a large building to serve as a new retail store. Central-shop changes include new welding facilities, centralized bit sharpening for both mining machines and rock drills, and an enlarged brass foundry. The recent changes and improvements leave no apparent gaps in a complete centralization of functions at Mount Hope, where the main executive and operating office is located.

Geographically, Mount Hope is close to the center of the New River

Co. group of mines in Fayette and Raleigh counties. All are served by hard-surfaced roads and the farthest is 10 miles from Mount Hope, which means approximately 30 minutes' travel for the shop and store-delivery trucks. In 1937 the company shipped close to 3,250,000 tons of prepared coal from the Sewell seam, which averages 3 ft. 6 in. in thickness. Three of the preparation plants have washing equipment.

Five of the mines are shaft operations, two are slope and three are drift. Generally speaking, the seam is nearly horizontal but contains numerous rolls which present difficult conditions for locomotive gathering and haulage. The list of underground machinery includes 141 locomotives, 70 shortwall mining ma-

chines, and 182 mine pumping units.

Centralization of maintenance at Mount Hope began in 1921, when a three-bay 90x120-ft. brick-and-steel main-shop building was erected. This building, with its excellent natural lighting, 10-ton floor-controlled bridge crane in the center bay, and manually operated bridge cranes in each side bay, stands today as a strictly modern housing for shop activities. In 1927, the original group drives of the shop machines were discarded in favor of individual motor drives. Adjacent to the shop and connected thereto by a covered monorail crane track stands a 100x200-ft. central warehouse of which a par-



Though built 17 years ago, this main building provides excellent housing for the shop work



This corner of the warehouse is used by the shop as storage space for repaired equipment



Brass and bronze castings aggregating 7,500 lb. per month are now made in the foundry

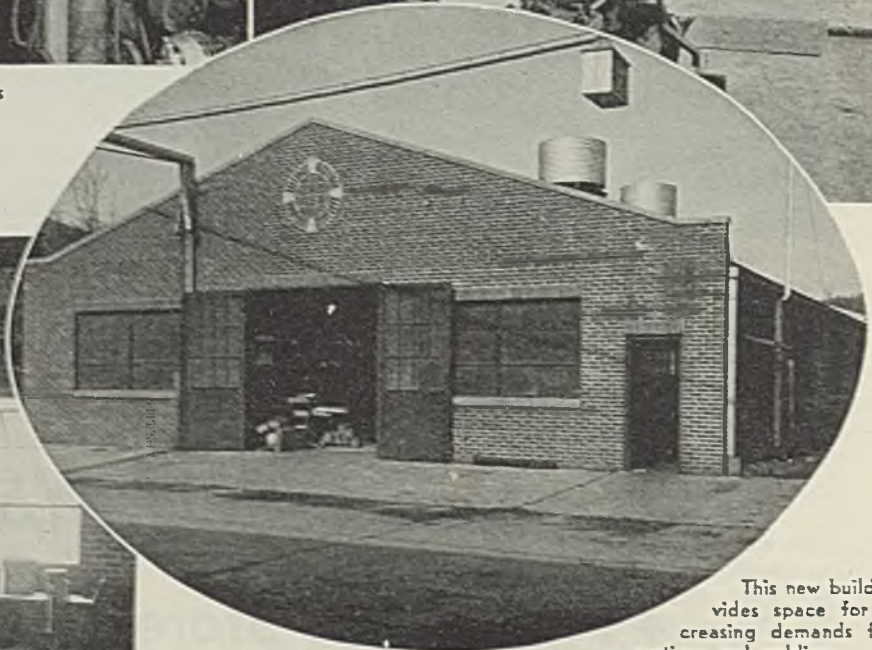

This new building provides space for the increasing demands for brass castings and welding.

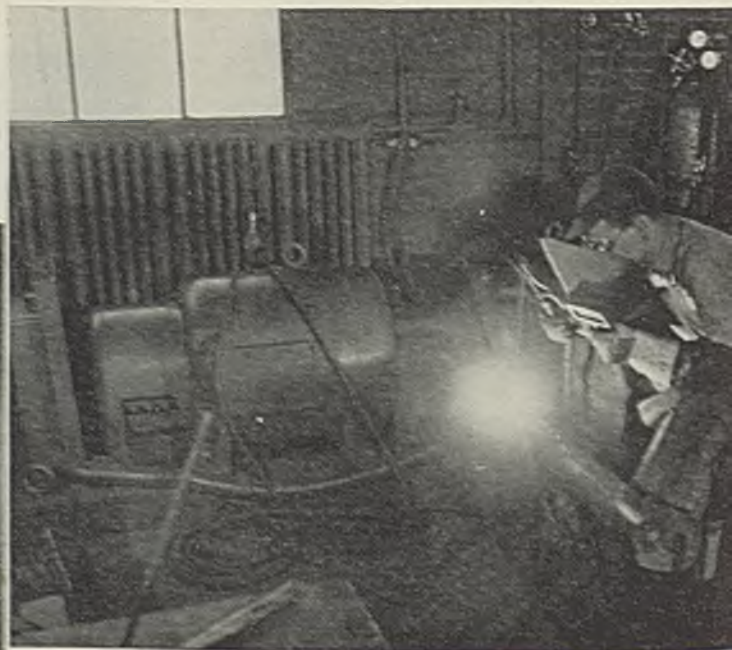

Building up a worn locomotive axle using coated electrode and current supplied by a new dual-unit machine standing in the background

tioned room 100x140 ft. at the front end is the warehouse for the company retail stores. The remainder, excepting a floor space 18x48 ft., is the warehouse for mine supplies.

The latter reserved space is under control of the shop superintendent and contains repaired armatures, repaired controllers and other electrical parts, and a few items such as pumps and motors. At present, the stock of spare and repaired armatures totals 116. Most of these are for 550-volt d.c. equipment, which is the standard at the older mines in the field. Power is purchased for all of the mines, and motor-generator sets constitute the substation conversion equipment.

In 1927, a brass foundry was added to the shop facilities and in two years the quantity of brass casting had reached 5,000 lb. per month. Now it amounts to 7,500 lb. per month and is done in a 30x50-ft. section of a new brick-and-steel building which also houses welding generators, five welding booths, a pattern and woodworking shop, and a blacksmith shop.

All requirements for brass parts and articles such as bushings, pump plungers, pole heads, harps and headlight cases are being met by the foundry. Equipment consists of a natural-gas furnace and 70- and 100-lb. graphite crucibles. All the scrap copper from the mines and from the

Table I—Arcwelding Electrodes and Gas-Welding Rods Used by the New River Co.

Class	Diameter, Inches					
	1/8	1/4	3/8	1/2	5/8	3/4
Fleetweld 5 (Lincoln) ..	X	X	X	X	X	X
Fleetweld 7 (Lincoln) ..	X	X	X	X	X	X
Low-carbon (Roebling) X	X	X	X	X	X	X
Hi-Test (Linde) ..	X	X	X	X	X	X
No. 25 bronze ..	X	X	X	X	X	X
Cast iron ..	X	X	X	X	X	X
No. 7 Iron ..	X	X	X	X	X	X
Aluminum ..	X	X	X	X	X	X
Linaweld ..	X	X	X	X	X	X
Cupros ..	X	X	X	X	X	X
Stellite ..	X	X	X	X	X	X
Tube Hay-stellite ..	X	X	X	X	X	X

winding department in the main shop is used for making brass and bronze castings. After the insulation is burned from the copper wire the latter is baled into 20-lb. "cabbages," which is a convenient size for charging the crucibles.

Forms used in the control of maintenance work at New River mines; A, daily report of mine electrician; B, double-faced perpetual card maintained in the Mount Hope office for each mining machine and locomotive; C, shortage report prepared at the end of each month by the clerk at Mount Hope; D, form for recording maintenance cost on mining machines—accumulated daily for one month; E, similar form for accumulating maintenance cost on locomotives.

Bearing bushings are made from half new metal and half scrap bronze and their composition is proportioned 80 per cent copper, 10 per cent tin, and 10 per cent lead. Pump plungers are made from new metal mixed 90 per cent copper and 10 per cent tin. Pole heads and harps contain 70 per cent copper, 28 per cent zinc, and 2 per cent aluminum. Tin, zinc and lead are purchased as new metals. Scrap aluminum, principally engine crankcases, is purchased to fill the aluminum requirement.

The old foundry building, a 20x40 ft. steel-framed, metal-sheathed structure, was converted to a sharpening and treating shop for mining-machine bits. Beginning of this centralization of bit sharpening dates back two years. In January of this year, 57,408 bits were sharpened, and in February the number was 42,681. The practice consists of repointing in a Diamond sharpener followed by air cooling, reheating the point and dropping the whole bit into Houghton's No. 2 quenching oil. The heating is done in a Diamond furnace using natural gas.

Dimensions of the new brick-and-steel building which shelters the welding shop and foundry are 50x80 ft. Along one side and facing the center aisle are five welding booths each 9x16 ft. Partitions 5 ft. high and made of corrugated galvanized metal

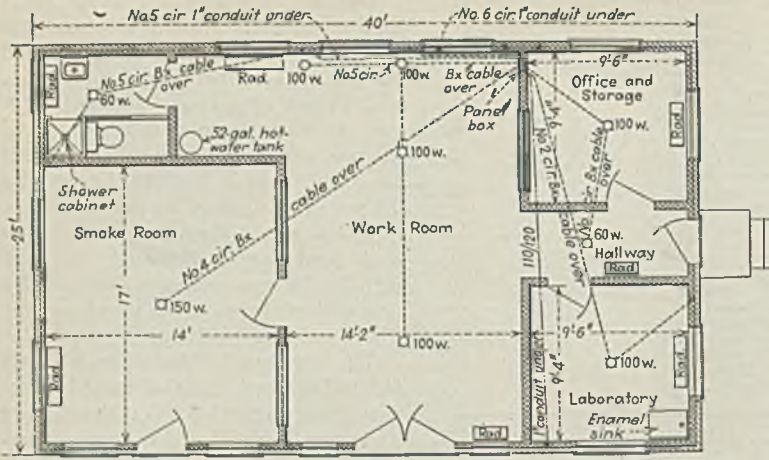

Floor plan of the new mine-rescue station built near the central shop.

separate the individual booths and also separate the foundry section from the remainder of the floor space. Draw curtains of the same height from the aisle ends of the booths to protect other workmen from the arcs.

Electric welding equipment consists of a Lincoln 300-amp. machine, which was moved from the welding department formerly located in the main shop, and one new Westinghouse "Flexare" dual unit driven by a 50-hp. Type CS induction motor. Each generator of this dual unit is rated at 300 amp.

Gas welding and cutting are done in the same booths and the acetylene supply is piped from a separate building which contains a generating outfit. The gas also is piped to the main shop, where certain heavy cutting and welding are done. Thirty-seven items of electrode materials and gas welding rods (see Table I) are stocked in the warehouse. Tire filling by arc welding was given a brief trial some years ago, but, on

account of breakage, was discarded in favor of turning to the lower limit and then scrapping the tires.

Practically all of the gathering locomotives operated by the company have been completely rebuilt and modernized in the Mount Hope shop. Armature winding, which normally engages six men, is done in a corner of the main shop adjacent to the shop office. Coils are purchased and all of the rewound and repaired armatures are dipped and then baked at 212 deg. F. in a natural-gas oven. Tests on all armatures are made with a bug (a.c. magnet) and the insulation to ground is checked by applying 1,000 volts more than the rated voltage. The 500-volt armatures are tested at 2,200 volts.

Although the shop is operated on a system whereby each man must charge his time to individual jobs worked upon each day, complicated methods are avoided so far as possi-

This 55x140-ft. building was remodeled and fitted as a new store and the old store across the street maintained as a showroom for furniture and appliances.

ble. As an example, instead of furnishing to the machinists dimensional drawings showing the proper finishing of brass castings, a standard sample of each of the common types is kept in the tool room to serve as a model. This reduces the chance of errors and saves the cost of making drawings.

Three truck drivers reporting to the shop superintendent make all deliveries of new material from the warehouse to the mines and also transport equipment and parts to and from the shop and mines. It is the duty of the driver to attach to each piece of equipment unloaded at the shop a brass tag indicating the mine from which it came. Also, he leaves with the shop clerk a list of the items unloaded. The clerk then assigns a number to each job and attaches two cloth tags bearing the number. When the job is completed the workman removes one tag and turns it in to the shop office with his time card.

In addition to C. R. Heermans, who has been superintendent of the shop since 1921, the force consists of 57 men. These are: two mechanics, who regularly go out to the mines when needed; twelve machinists; six armature winders; three electricians, who overhaul stationary motors, locomotives, mining machines and so on; two blacksmiths, and two helpers, who rebuild cages and do general smithing work; five welders; two foundry molders and two molder helpers; two bit sharpeners; three truck drivers; two resistance builders; one pattern maker and wood worker; one janitor; eleven shop helpers, and one clerk.

Adoption of jackbits and the installation of an Ingersoll-Rand sharpener in the main shop centralized another item of maintenance

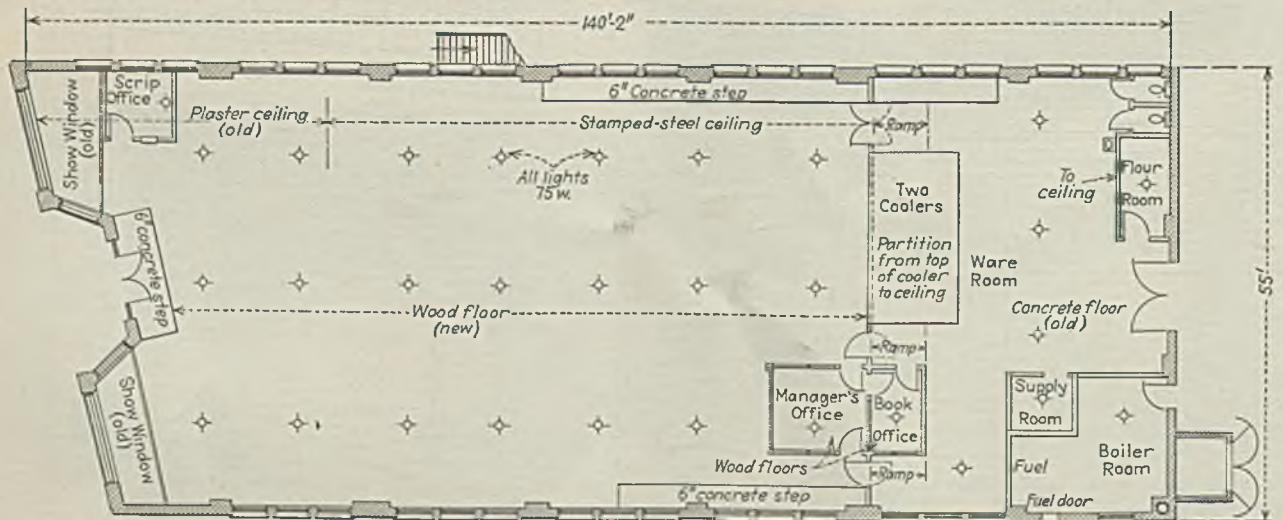

are stored to one side

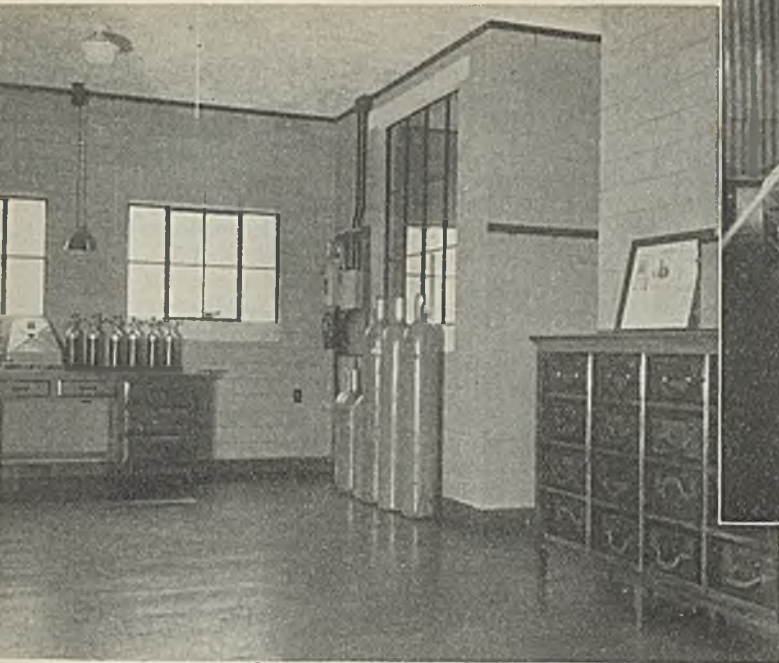

Centralization of bit sharpening at Mount Hope leaves room for mine-car repair work at the mines

These buildings are (left to right): welding shop and foundry, bit-sharpening shop and mine-rescue station

Left to right: retail store; front end of building housing mine supplies and retail stores stock; and the main office

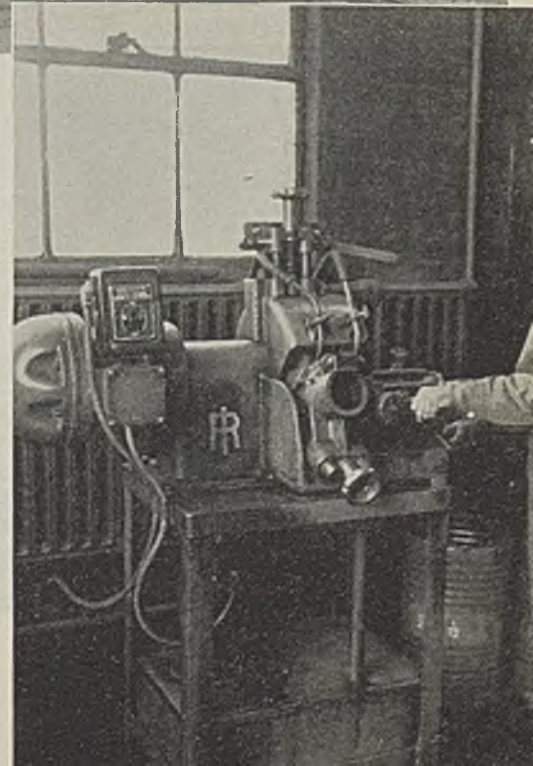
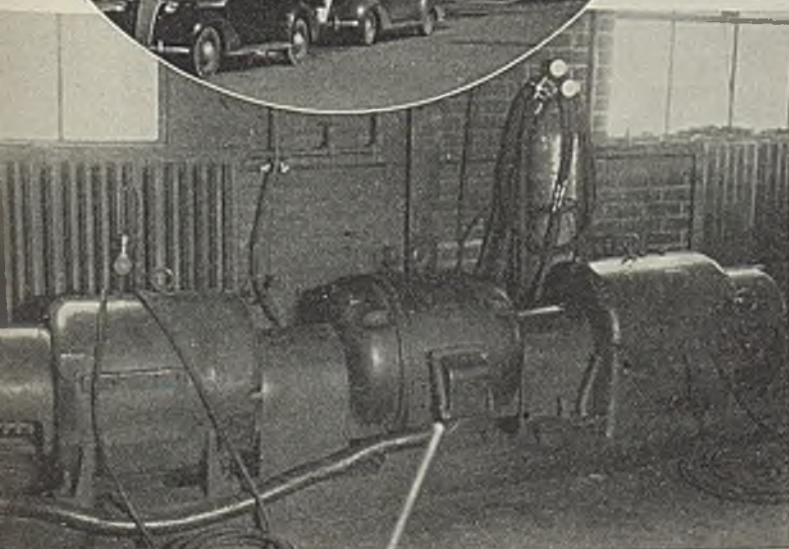
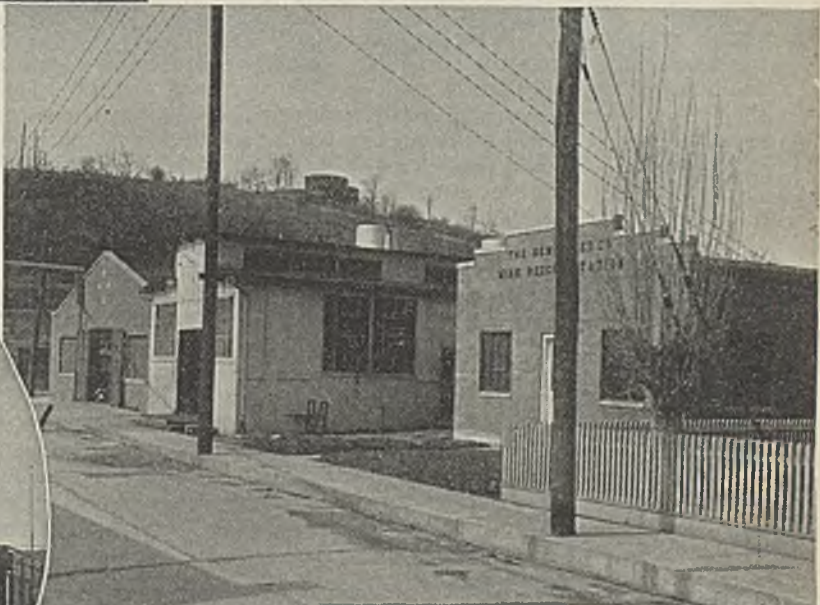
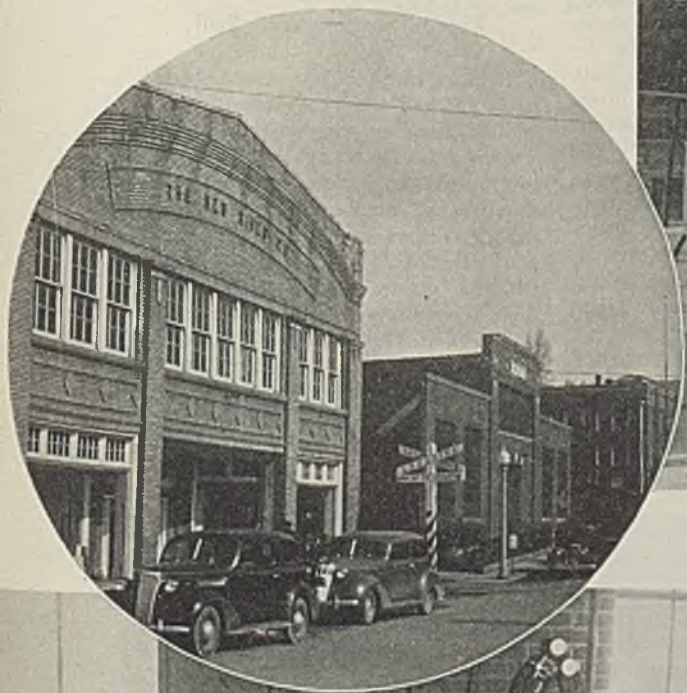

This dual welding unit was purchased for the new welding shop. Each generator is rated 300 amp.

All rock drilling is now done with jack-

work at Mount Hope. The $1\frac{1}{8}$ -in. bits with Type O thread are resharpened two or three times or until the gage is reduced to $1\frac{1}{4}$ in., after which they are junked.

Maintenance men working in and about the mines report to division maintenance superintendents, whose rolls include mine electricians, bond men, pump operators, hoisting engineers and substation operators. C. C. Ballard supervises one division and K. F. Humphries the other. They use a system of reporting and checking maintenance items and costs which was developed by Mr. Ballard and which involves a minimum of clerical work. Executives of the company estimate that this reporting system has been worth $1\frac{1}{2}$ c. per ton. The cost of operating the system consists of the cost of the stationery—i. e., the printed forms used—and of the salary of an operating-department clerk, who works in the central warehouse office, where the material-cost records are conveniently available. Large card records of maintenance currently posted for each individual locomotive and mining machine, together with the names of the motormen or machine operators, are kept on file in that office for inspection by the maintenance superintendents and other operating officials.

The accounting originates with a "Daily Report of Material and Labor Used on Locomotives and Mining Machines," which is one of four forms used in this maintenance accounting. The mine electrician fills out the first mentioned form, keeps a copy himself, hands a copy to the mine superintendent and sends the

original to the Mount Hope warehouse office via the main operating office. Each day the clerk prices the repair items and transfers the information to the individual cards for the respective mining machine or locomotive. Central-shop items and their charges are entered in red on the card and so are easily distinguished from the mine-repair items.

An accumulated cost-to-date report of total locomotive and mining-machine maintenance cost for each mine is posted each day. Then at the end of the month a shortage report is made to show the total cost of the items which were sent from the central warehouse to the respective mines but through oversight were not included on the daily reports made out by the electricians. The amount of shortage then is charged pro rata to the individual machines.

Equipment operators watch mine-posted copies of the reports to compare their costs with those of the other operators and often call the electrician's or maintenance superintendent's attention to an erroneous charge. The card records of accumulated costs kept in the central warehouse office are examined by the division maintenance superintendents to locate offending machines or operators when maintenance costs mount. Prior to 1930, the date when the individual machine accounting was started, there was no convenient way of putting a finger on the exact source of a high maintenance cost at a certain mine.

Changes in material and labor costs mitigate against the value of comparisons over long periods of

years. However, it is of interest that present maintenance costs are approximately twice what they were in 1922. For the year 1937 the labor-and-material maintenance cost of the main-haulage locomotives was 2.17c. per ton; gathering locomotives, 1.12c.; and mining machines, 1.97c.

In February this year there was completed a 25x40-ft. single-story brick building which now houses a mine-rescue station. This is back of the main shop and not over 500 ft. from the company office building. It is partitioned into five rooms: (1) a laboratory for analyzing mine gases and dusts, (2) an office intended for both desk and storage space, (3) a workroom in which the mine-rescue apparatus and gas masks are stored and which serves also as a training and lecture room, (4) a smoke room, which is the gas chamber for apparatus drills, and (5) a toilet and shower bath. The office equipment consists only of a desk for miscellaneous use because the office of the director of safety (E. H. Graff) is in the main office building.

Rescue Station Well Built

Ceiling height in the rescue station is 10 ft. and the roof structure and ceiling are supported by Consteel Type SJ-123 joists set on 20-in. centers. Posts, braces, rafters and sheathing of wood support a hip roof having a slope of 2 in. in 12 in. and consisting of Johns-Manville "Super-Class A" asbestos construction. The floor is concrete which was first varnished and then painted a medium green. Heating is by steam radiators supplied from the boiler of the shop-heating system and the temperature in cold weather is maintained at 65 deg. F.

Equipment of the station is as follows: six McCaa self-contained 2-hour oxygen breathing apparatus, one motor-driven high-pressure pump for charging apparatus cylinders with oxygen at 1,980 lb. pressure, fifteen "All-Service" gas masks, one H-H inhalator, twelve M.S.A. self-rescuers, two M.S.A. carbon-monoxide detectors, one U.C.C. methane indicating detector, one M.S.A. methane detector, one M.S.A. Volumeter (for determining percentages of rock and coal-dust mixtures), and one Burrell portable gas-analysis apparatus. The supplies kept on hand in the station include one 125-cu.ft. cylinder of "Carbogen" (93 per cent oxygen and 7 per cent carbon-dioxide) for use with the inhalator, three 200- and three 125-cu.ft. cylinders of oxygen, six small extra oxygen

Wide aisles, adequate lighting and modern metal showcases characterize the new retail store.



cylinders for breathing apparatus (each holds 270 liters of oxygen at 135 atmospheres pressure), 200 lb. of "Cardoxide" for breathing apparatus (4 lb. per 2-hour charge), and 40 extra canisters for the "All-Service" masks.

Two to three mine-rescue teams of six men each are maintained at each mine. All training is done in cooperation with the U. S. Bureau of Mines and with the West Virginia State mine department.

Need for a larger and more attractive room for the general store conducted by the New River Co. in Mount Hope was met by acquiring

and remodeling a 55x140-ft. brick building which stands just across a railroad from the warehouse building, the front section of which contains the general stock for the thirteen retail stores operated by the company. The former Mount Hope retail storeroom, which is across the street and somewhat closer to the main office building, is maintained as a showroom for furniture and electrical apparatus.

Only the ground floor of the remodeled building is delegated to the new store. It is fitted with Lyon Metal Products metal showcases. Meat shop, coolers, offices, flour room

and heating room are all provided with modern equipment. Delivery trucks back directly into the warehouse for loading, thus saving steps and nullifying the effects of stormy weather. C. H. Duncan, store manager, is justly proud of the new layout and does not slight the furnace room when showing a visitor around his "plant." Heat is supplied by a No. 3 "Ideal Redflash" boiler fired by an Iron Fireman stoker using the special smokeless stoker fuel which is a featured product of the White Oak Fuel Co., selling agent for coals produced at the New River Co. mines.

STRIPPING EFFICIENCY + Raised by Measuring Effective Work By Time-Study Methods

By GENE H. UTTERBACK

*Production Engineer
Enos Coal Mining Co.
Oakland City, Ind.*

THE ENOS COAL MINING CO., operating a strip mine near Oakland City, Ind., has employed time-study principles in jobs and methods analysis for approximately ten years. When strip mining first began, the average operation presented a picture of overburden being moved by construction equipment and methods to make way for the coal to be taken out the same way. The present picture is quite different. Strip mining is an industry in its own right and now bears slight relationship to construction work. Highly specialized equipment and methods prepare and move the overburden, followed by equally specialized equipment and methods for removing the coal and preparing it for market. While time study for job and methods analysis has had a part in this development, it now has a much wider use for production and cost control.

It is not the intention of this article to discuss the merits of different time-study methods, therefore the technique of making time studies will not be gone into. The field-

study method used at Enos, in the main, was an adaptation of the Bedaux method to our operations and purposes. Some of the production standards were established on the basis of 60 Bedaux units per hour, while other departments and operations were set up without regard to the Bedaux method of measurement.

Labor is not like an ordinary commodity, to be bought and sold on the open market. The personal element of skill, ingenuity, fatigue, cooperation and ambition raise the accom-

plishments of labor to a plane of dignity that cannot be touched by a mere commodity index. Nevertheless, labor's compensation and its effect on the cost of the thing it produces are so vitally intermingled with the ebb and flow of economic tides that it is becoming more and more essential to know something about the productivity of labor. The purchaser of labor is entitled to know

Fig. 1—Showing graphically production during one drill shift at Enos mine

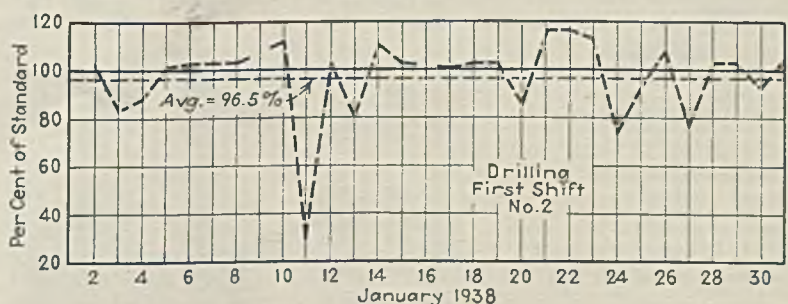

what he can expect for his money and the seller is entitled to know what he can give honestly. Time study for setting production standards establishes this value. Labor should have no quarrel with time study. No company has the right to waste the labor of this country in a non-profit-making enterprise, and labor should welcome time study as a means of establishing a fair value on its services in order that the pur-

chaser may operate at a profit and so justify his existence in that capacity.

The purpose of time study is to measure effective work. It seeks to eliminate waste effort, lost time and inefficient management, and when properly applied to production-standard setting keeps before workers and supervisors the output that can reasonably be expected from any production unit. Time study is

not an end in itself but a means to an end, and while the mere making of a study may have a temporary salutary effect, if any permanent benefits are to accrue the results must be correlated to record a measurement of human energies, machine activities and management efficiency. Education can be defined as a whetting of the faculties of perception by which we are enabled to discern realities; and similarly,

Fig. 2—Stresses developed in 750-B stripping shovel in two digging positions

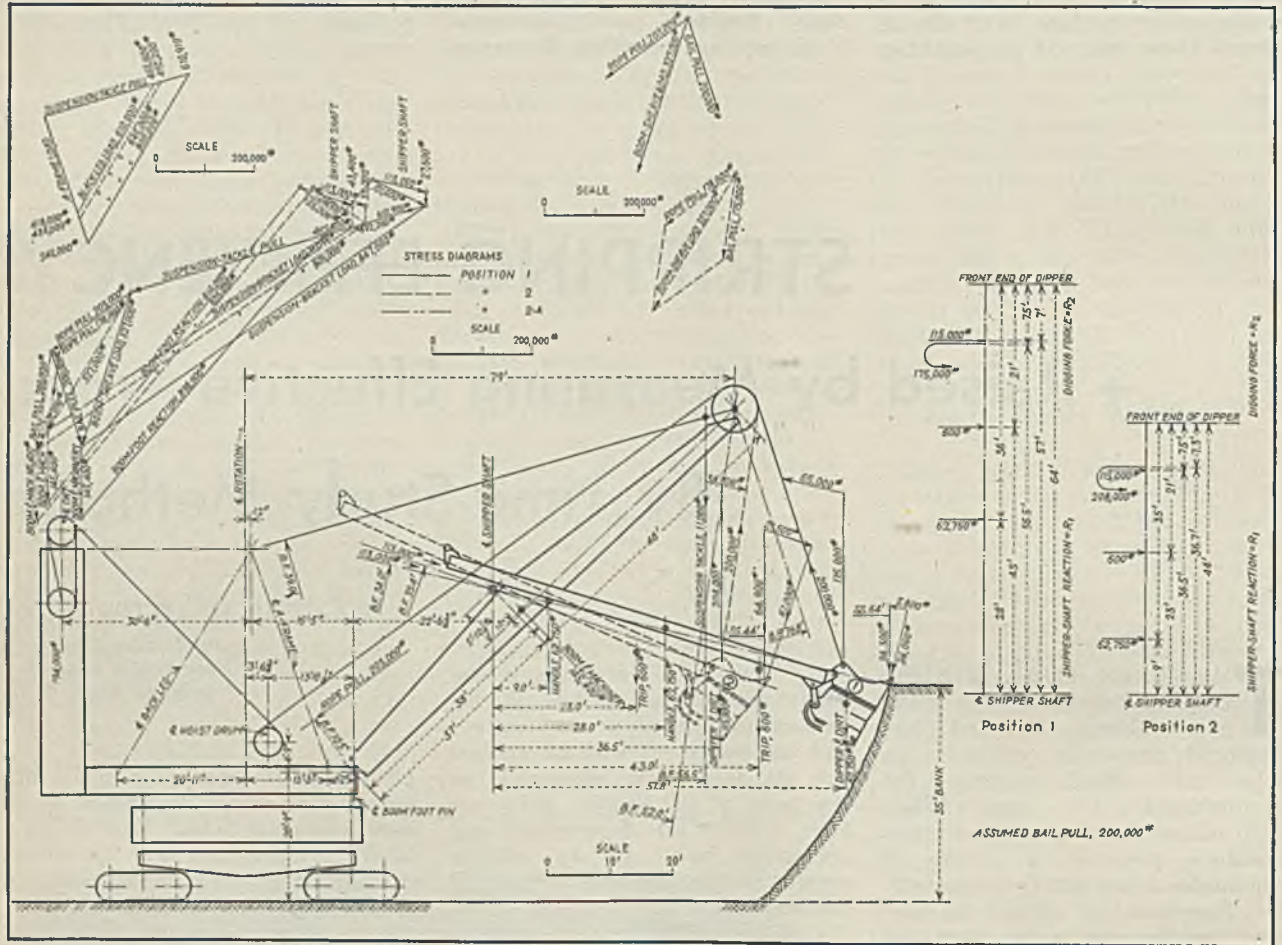

Front-End Reactions

	Position 1			Position 2			Position 2-A		
	Weight, Lb.	Arm, Ft.	Moment, Ft.-Lb.	Weight, Lb.	Arm, Ft.	Moment, Ft.-Lb.	Weight, Lb.	Arm, Ft.	Moment, Ft.-Lb.
Digging Force:									
Dipper and dirt	115,000	57	6,555,000	115,000	36.5	4,197,500	115,000	36.5	4,197,500
Bail pull (vert. component)	-175,000	56.5	-9,887,500	-208,000	36.7	-7,633,600	-159,200	36.7	-5,845,200
Dipper trip	600	4.3	25,800	600	23	13,800	600	23	13,800
Dipper handle	62,750	28	1,757,000	62,750	9	564,700	62,750	9	564,700
Available digging force	-24,300	64	-1,549,700	-64,900	44	-2,857,500	-24,300	44	-1,069,200
Shipper-Shaft Reaction:									
Dipper handle	62,750	36	2,259,000	62,750	35	2,196,200	62,750	35	2,196,200
Dipper trip	600	21	12,600	600	21	12,600	600	21	12,600
Bail pull (vert. component)	-175,000	7.5	-1,312,500	-208,000	7.3	-1,518,400	-159,200	7.3	-1,162,200
Dipper and dirt	115,000	7.0	805,000	115,000	7.5	862,500	115,000	7.5	862,500
Shipper-shaft reaction	27,600	64.0	1,764,100	35,300	44	1,552,900	43,400	44	1,908,600
Suspension-Tackle Pull:									
Boom and machinery	145,400	38.0	5,525,200	145,400	38.0	5,525,200	145,400	38.0	5,525,200
Shipper-shaft reaction	113,000	34.0	3,842,000	113,000	35.4	4,000,200	113,000	35.4	4,000,200
Shipper-trip	27,800	22.56	622,700	35,300	22.56	796,400	35,300	22.56	796,400
Hoist-ropes pull	-203,000	10.5	-2,131,500	-203,000	10.5	-2,131,500	-178,000	10.5	-1,869,000
Bail pull (total)	200,000	76.8	15,360,000	200,000	52.0	10,400,000	175,000	52.0	9,100,000
Suspension cables and sheaves	11,000	56.5	621,500	11,000	56.5	621,500	11,000	56.5	621,500
Sheave friction			-15,000			-15,000			-15,000
Suspension-tackle pull	610,900	39.0	23,824,900	492,200	39.0	19,196,800	465,600	39.0	18,159,300

we can say that time study is a tool for whetting the perception by which we discern the facts, or realities, about the work going on around us. Time study is not an exact science and its success depends largely on the accuracy, experience and, above all, honesty of the time-study engineer and his ability to judge human efforts. Yet it is surprising how close will be the results obtained by two experienced time-study men analyzing the same operation independently.

Coal-stripping operations may be divided into the following classifications: drilling the overburden, blasting, stripping, loading the coal, haulage (which in the operation under discussion is divided between truck haulage in the pit and electric-train haulage from pit to tippie) and preparation. Each branch of the work will be described in sufficient detail to show how and why the standard was so established; what changes in supervision were necessary, if any; and how control is accomplished by the use of graphic records. For the purpose of this article no actual production figures will be used, but where it is necessary to illustrate, production figures have been plotted in percentages relative to 100 per cent as standard.

Study Improves Drilling

Drilling and Blasting—When horizontal drilling first replaced the conventional well drill, the savings were so pronounced that no one gave much thought to ways and means of improving the new method. In fact, everyone was very happy about the whole thing for some time. When the drilling operation was finally analyzed by time study, it was found that a number of unnecessary holes were being drilled and that the variation in direction was sufficient sometimes to cause improper breaking of the bank. As a result of this investigation an engineer was put in charge of the work and it became his duty to lay out each drillhole from a transit base line in the pit; carry the information day by day on a 20-ft.-to-1-in.-scale map and calculate the yardage of the bank to be broken before it was shot. In other words, each drillhole was to be treated as an individual problem both as to drilling and shooting. As a later development, when another stripping unit began operating, it was deemed advisable to put a full-time supervisor in charge of the field work, as the engineer's time was taken up in laying out holes and

calculating yardages. When it is known that as much as 1,000,000 cu. yd. of overburden has been drilled and shot in one month's time it is not difficult to visualize the amount of work involved in the engineering control.

In connection with the investigation of this work, time studies brought out the amount of drilling that could be expected as standard performance. Quite recently another series of studies was made and the results checked the original set-up within 1 per cent, showing that the drilling operation had not undergone any great change in four years. Fig.

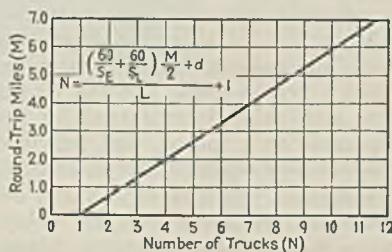

Fig. 3—Typical graph derived from equation for the number of trucks required to keep a loader busy

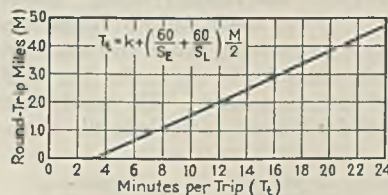

Fig. 4—Graph derived from equation showing time required for a truck to make a trip

1 is a graphic representation of the production of one drill shift during the month of January, 1938. (Since the production charts for the other departments are similar to this one in construction it can be taken as typical.)

Drilling conditions are generally good. While the bank formations are quite variable it usually is possible to drill in one of the beds of gray shale nearly always present over the No. 5 coal. Where the bank is high (over 50 ft.), the holes are drilled at two levels, the upper-level holes being staggered with respect to those on the lower level and also sloped upward to give access to the upper part of the bank. All of these usual and unusual conditions were studied and taken into account when the standard was established, and subsequent records have shown the studies to be quite accurate. A casual examination of Fig. 1 will show that

standard was equalled or excelled in a majority of the shifts for January. This same shift consistently drilled 20 to 40 per cent below the standard before any systematic effort was made to get the production where it belonged. Before the standard was established the number of opinions as to what constituted a normal day's drilling was exactly equal to the number of persons submitting the opinions. Time studies uncovered the weaknesses in the operation; the results are obvious.

The blasting operation was considerably more difficult to study and set up than the drilling. Blasting work is essentially a group performance and the best results were obtained from group performance studies. Individual studies also were made in order to measure the effective work performed by each operator, but the ultimate set-up had to cover a group performance. The standard capacity of the blasting crew, the size of which varies, was determined in production per man-hour, and the graphic record of that operation shows the daily performance relative to 100 per cent as standard.

Blast With Liquid Oxygen

The blasting medium is liquid oxygen manufactured at the company's plant about seven miles from the pits. It is hauled to the field by truck in soaking boxes containing 72 4½x20-in. cartridges. Two crews of three men each comprise the regular shooting force, one crew working behind each stripping unit. The change from vertical to horizontal drilling reduced the work of shooting to such an extent that seldom does a crew work at more than 75 per cent of capacity, even with the stripping unit operating full time. The shooting standard was established on the basis of the number of L.O.X. cartridges shot per man-hour worked. Because of the many and variable conditions incidental to the blasting work, a great many time studies were necessary before the standard could be determined. Weather conditions affect this type of work to a great extent also, and, as a result, the studies were extended over a considerable period of time in order to record the work accomplished under all conditions.

The importance of blasting work should not be underestimated. The bank to be shot at the Enos mine seldom is easy and often is unusually difficult. A uniformly well-shot bank should be, and is, the aim of every shooting crew, shooting boss, pit

boss and superintendent, since it affects the stripper production to such a great extent. The best shovel operator in the strip field cannot move yardage if it has to be chiseled out with the dipper. Prepare the bank properly and even a poor operator can make a fair showing. Installation of engineering control over the drilling and blasting resulted in a cost reduction of about 25 per cent.

Stripping—If it has not already been suspected by those readers with sufficient fortitude to bring them this far, let it be said now that the term “time study” may be something of a misnomer for all of the study work that is carried on at the Enos mine. Time study is used to establish time values, production standards and cost standards but, in order properly to study a stripping operation, time study must be supplemented by a complete methods analysis.

The cost of stripping can make or break a strip operation, hence the importance of introducing efficiency methods into that phase of the work. There is a best way to dig a given type of bank, and there also is a best way to spoil or waste the excavated material. There is a best position for the shovel to be in with respect to the digging face in order that the stresses developed throughout the shovel are kept at a minimum and the available digging effort at a

ging effort with the least amount of power.

Standard production for a stripping shovel depends chiefly on the following factors: a well-shot bank, getting the dipper as full as possible each pass, the over-all cycle time, and keeping shovel delays at a minimum. Time studies are made to determine accurately the digging-cycle time under all conditions, as well as all other repetitive elements that enter into the operation. Time studies made in accordance with Bedaux practice not only measure the time required to perform a given operation but also the effort expended by the operator, his skill, and the consistency with which he performs his work. All stripping-shovel delays are recorded automatically on clock vibrator charts and the reason for each delay is explained by the operator on a special card provided for that purpose. In calculating production, which is done daily, deductions are made for all delays other than so-called operating delays; i. e., oiling, cabling rocks, move ups, allowing trucks to pass, etc. Allowed delays are classified as follows: dead-heading, general repairs, mechanical trouble, electrical trouble, power trouble and other delays. These delays are recorded daily and summarized monthly to show the per cent of total time active. The production standard is set to include all neces-

are made before the loading shift to prevent delays short of complete breakdown. Production is easily figured in number of trips loaded per shift and the standard is set up on that basis. Numerous time studies have established the time required to load any size truck with any loader under all conditions, and the number of trucks needed to keep a loader busy can be determined from the formula

$$N = \frac{\left(\frac{60}{S_e} + \frac{60}{S_l}\right) \frac{M}{2} + d}{L} + 1$$

where N =the number of trucks; S_e =empty speed in miles per hour; S_l =loaded speed in miles per hour; M =round trip distance in miles; d =dumping time in minutes; and L =loading time in minutes. Since the above equation is linear, two assumed values for M establish the curve from which values for N can be read direct for any given distance. Values for S_e , S_l , d and L must be established by time study. Fig. 3 is typical graph of the foregoing equation.

Truck Haulage—If a 20-ton truck is expected to haul not less than 500 tons per shift it must take 25 trips in the given time and therefore it becomes necessary to know the maximum distance over which the given tonnage can be hauled. The same

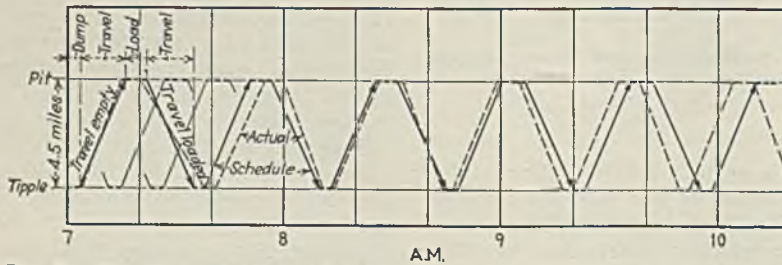

Fig. 5—Graphic comparison of actual time of travel of one main-haulage train with standard time established by time study

maximum. The accompanying diagram (Fig. 2) shows the stresses developed in different members of one type of shovel in two different digging positions. A careful examination of this diagram will show that it is highly advantageous to work the machine as close to the digging face as possible in order to make the most of the available dig-

sary operating delays and the daily graphic record is plotted on the basis of cubic yards dug per hour operated.

Loading—Determining standard production for the loaders is a comparatively simple matter—in fact, one of the easiest of all production units in strip mining. The loaders work only seven hours and all preparations

time-study data used in deriving the formula for the number of trucks needed for a loader also can be used to calculate the time required for a truck to make any given trip. The formula is

$$T_t = \left(\frac{60}{S_e} + \frac{60}{S_l}\right) \frac{M}{2} + k$$

where T_t =trip time in minutes;

Fig. 6—Sample of production chart (January, 1938) used in the main-haulage department. The double line indicates that two shifts were worked that day.

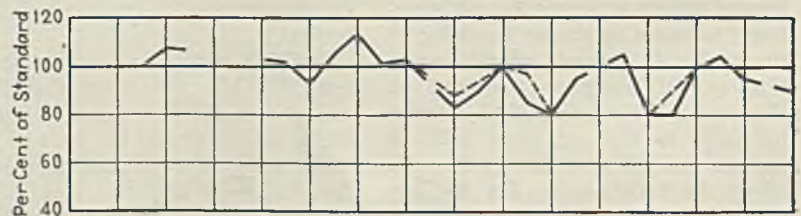

On to Cincinnati, Says Mr. Ireland



Cincinnati Music Hall—Coal-Trade Center, May 2-6

"Why one should attend the Cincinnati convention-exposition of the American Mining Congress the week of May 2 needs no long-winded statement. If a coal man has been to the Cincinnati coal convention he doesn't need to be told; if he hasn't been it is time he went and found out."—*R. L. Ireland, Jr., National Chairman, Program Committee, American Mining Congress.*

S_e =empty speed in miles per hour;
 S_l =loaded speed in miles per hour;
 M =round trip distance in miles; and
 k =the loading time plus dumping time in minutes.

This also is a linear equation, two values of T_t establishing a curve from which trip time can be read direct for any distance. There is a different curve for each size loader as well as for different capacity trucks. If a truck is expected to make 25 trips per shift the graph will show the maximum distance at which they can be made. Fig. 4 shows this equation plotted for one loader and 20-ton trucks. Truck-haulage production is measured in trips and ton-miles, and the graphic record shows daily results plotted against the predetermined standard.

The use of motor trucks for pit haulage in strip mining is a fairly recent development and with its advent have come a number of problems that fall within the province of time study for solution. The work of the time-study engineer in this department is not limited to the establishment of time values but must be broadened to include such problems as road construction and the effect of grades on time values; the economic limit in miles beyond which the investment cost per ton hauled becomes top heavy; and the ever present problem of equipment and road maintenance.

Main Haulage—The electric haulage at Enos (April *Coal Age*, p. 50) presented an interesting but not particularly difficult problem in time study. The distance is fixed along with the size and number of trains.

Fig. 5 shows, graphically the actual travel time of one train plotted against the standard time established by time study. The main-haulage standard is one that was set up on the basis of 60 Bedaux units per hour. For comparative purposes the standard was set up on the number of cars dumped per loading shift. Fig. 6 is a sample of the production chart used for this department, the double line indicating that two shifts were worked on that day.

A production standard is a yardstick for gaging individual, departmental, supervisory and/or plant efficiency, and this productive capacity or standard can be determined accurately only by time study. After the standards are established, the problem of presenting the data to the supervisors and management must be solved, since the knowledge obtained is of no value unless it is passed on to the men who can do something about it. Graphic records are easily understood and are especially valuable because they show constantly the relative comparison between past records, present performance, and standard. Charts showing departmental activity in the proper units are kept posted daily. Drilling is shown in linear feet drilled; blasting in L.O.X. cartridges shot per man-hour; stripping in cubic yards moved per hour operated; loading in number of tons loaded per shift; electric haulage in number of cars dumped at the tippie; and the tippie in number of tons over the scales. Each foreman is expected to keep himself informed daily as to the activity of his department. Low

points on the record command his attention and, since the record is daily, his memory of what caused the low point enables him to take whatever remedial steps are necessary or possible to prevent recurrence.

In addition to this, monthly foremen's meetings are held at which it is possible to discuss in detail any operating problem. Grievances are ironed out, one of the purposes of the meeting being to help each man see his work in relation to the whole. Production charts are discussed, along with departmental costs or any other topic of interest, and an honest effort is made to promote a friendly spirit of cooperation. These meetings are an important part of any control program in that they tend to make everyone cost conscious.

In the words of Harrington Emerson, the first principle of efficiency is "a clearly defined ideal," and for time study to be successful it must follow a definite course of action and it must forge ahead to that end without deviation. A group of hit-or-miss time studies may produce some very interesting information, but, unless the studies are correlated in accordance with a clearly understood plan, they had might as well be catalogued as "Interesting Information" and filed away in some dark record room. Miscellaneous time-study information, if taken at its face value, may increase our problems instead of solving them; but with production control and, of course, cost control as the aiming point, time study becomes one of the most valuable tools management has at its command.

NEW CLEANING PROCESS—

+ Heavy Organic Liquids Used for Separation In Sink-and-Float Process

By W. B. FOULKE

*Director, Minerals Separation Division
R. & H. Chemicals Department
E. I. du Pont de Nemours & Co., Inc.*

THE ADVANTAGES of straight gravity separation long have been recognized by all familiar with the art of coal beneficiation. Authentic records show that ferric chloride and sulphuric acid were suggested as "parting liquids" as early as the middle of the nineteenth century. In fact, about that time English experimenters tried unsuccessfully to run the ferric-chloride process in competition with jigs. Since then efforts to use parting liquids for both coal and ore cleaning have been made by many individuals and corporations.

Application of these principles to a new process of cleaning now has been thoroughly demonstrated at a plant erected in the anthracite region. Back of this success, however, was more than thirty years' investigation and experiment. Research into the possibilities of a process using high-gravity liquids as a separating medium for minerals was sponsored early in the present century by T. Coleman, Pierre S. William, and Francis I. du Pont. Work was started on Virginia limonite at the du Pont Co. Experimental Station about 1904 under the supervision of A. J. Moxham.

Molten Liquids First Used

Because suitable parting liquids were not then available in commercial quantities, this work was limited to developing a process using molten bromide of antimony or tin. Though successful in producing a high-grade concentrate, difficulties of procuring materials for making the molten parting liquids and the high cost of the process ended this particular development. But research to develop parting liquids with the proper specific gravities and low enough in cost for large-scale com-

mmercial use continued until the World War, when work was curtailed.

Continuance of the program in 1919 was sponsored by Francis I. and William du Pont, and Mr. Moxham constructed a pilot plant. Prevailing low prices for concentrates and the operating costs of the process, however, militated against the development and Mr. Moxham's death in 1922 brought this phase of the research program to a standstill. Early in 1927, Major Adriaan Nagelvoort, who had been associated with Mr. Moxham, persuaded the Delaware Chemical Engineering Co. (the laboratories of Francis and Alfred I. du Pont) to resume research along the lines previously followed.

By that time the art had been so far developed that it was apparent any heavy-gravity liquids to be suitable for the "parting liquid" should have these general characteristics: specific gravities of at least 1.3 to 3; low vapor pressure at working temperatures; low melting point; minimum miscibility with water; stability toward water, air, light and heat; freedom from any tendency to emulsify with water; approximately the same viscosity as water; good mobility at working temperatures, and low cost.

Minimum miscibility with water in both phases was believed to be the most important requirement, as any parting liquid in which water is soluble would decrease in specific gravity with use, making it necessary to expel the water from the liquid and return the latter to its proper density; any parting liquid soluble in water would result in increased liquid loss. Mr. Moxham had believed that wetting the minerals with water prior to immersion in the parting liquid would materially re-

duce the liquid loss—provided that the liquid was not miscible with water. Major Nagelvoort discovered that the application to the solid of a film of any liquid not miscible with the parting liquid considerably altered the effective gravity of the solid and made possible the use of cheaper parting liquids.

Parting-Liquid Standards

Halogenated hydrocarbons, as represented by tetrabromethane ($C_2H_2Br_4$), specific gravity 2.964; pentachlorethane (C_2HCl_5), specific gravity 1.678; and trichlorethylene (C_2HCl_3), specific gravity 1.462 at 20°C. — 4C., the investigators decided, should be considered the standard parting liquids. Low miscibility with water is a property shared by all these compounds.² As it was probable that the gravities at which these liquids were manufactured would not be those required in actual practice, it was decided to secure the desired gravity by mixing any two of the liquids named in proper proportion or by diluting them with a suitable petroleum distillate.

Early efforts to develop a commercial process using these halogenated hydrocarbons as parting liquids were unsuccessful because of process and equipment difficulties. Several types of apparatus were constructed, and, although satisfactory separations from the standpoint of the final concentrate were made, liquid losses were still excessive and the equipment was unsuitable mechanically. Mechanical

² Although classed by the handbooks as insoluble in water, these liquids do have a measurable solubility in water. Pentachlorethane, for example, has a solubility of approximately 5 parts per 10,000 at ordinary temperatures. The solubility of water in pentachlorethane is negligible.—W. B. F.

¹ Registered trade name.

operation of the pilot plants was perfected by Charles W. Lotz, assistant consulting engineer, M. A. Hanna Co., who became associated with the Delaware Chemical Engineering Co. in 1930—the same year the author joined that organization.

On the basis of the work done by Mr. Lotz, the Hanna interests installed a commercial unit at the Pennsylvania colliery of the Susquehanna Collieries Co. The mechanical engineering on this unit was done by E. B. Worthington, mechanical engineer for Susquehanna, in collaboration with Mr. Lotz and R. S. Walker, chief consulting engineer, M. A. Hanna Co. While this unit functioned perfectly from the mechanical standpoint and turned out a premium-quality product equal to that made in a laboratory sink-and-float apparatus, parting-liquid loss was so excessive and the vapors escaping into the plant so hazardous for the workers that operation was discontinued and the equipment removed from the breaker.

Studies to eliminate imperfections in the process were continued in the laboratory of the Delaware company, where H. Lloyd Alexander, a staff chemist, in collaboration with Hubert I. du Pont and the author, discovered a fact which is chemically new and which turned an otherwise complete failure into a successful process. This discovery, in two words, is "active agents"—surface-active substances which immunize the solids against the parting liquid. A vapor-tight test machine to handle approximately 10 tons of buckwheat anthracite feed per hour was constructed. Extended test runs using active agents showed that the liquid loss was reduced far below the requirements for commercial operation. Francis I. and Hubert I. du Pont were responsible for the chemical engineering design of the unit.

Commercial Plant Built

After the demonstration of this unit, exclusive rights for the process were acquired by E. I. du Pont de Nemours & Co., Inc., who immediately proceeded to carry the development to actual commercial operation in a plant designed and installed adjacent to the Weston breaker of the Weston Coal Co. at Shenandoah, Pa. This plant, erected for the du Pont company by the Connery Construction Co., was started April 6, 1936, and by mid-May was ready to handle approximately 100 tons per hour on a continuous operating basis. Before discussing results, the author wishes to thank T. M. Dodson and B. Helm Stockett, Weston Dodson & Co., Inc.,

for their cooperation during the evaluation of the process.

Arrangements were made to carry the feed from the Weston breaker's preliminary sizing screens to the adjacent sink-and-float (Shenandoah) plant so that the feed to the plant could be any size or mixture of sizes required for test. Refuse, run-of-mine or prepared coal from other collieries can be delivered in railroad cars to the breaker's condensed-coal elevator boot, carried into the breaker, over the preliminary sizing screens if desired, and thence to the sink-and-float plant.

The finished product from this plant is conveyed back to the breaker, where it is sized on the usual shaker screens. Loading pockets in the breakers are divided so that the product from the sink-and-float plant is not mixed with that from the jigs used in the regular colliery operation. Refuse from the sink-and-float plant is conveyed to the breaker refuse pocket, picked up by a lorry and sent to the refuse bank with the regular colliery refuse.

A building approximately 48 ft. long, 40 ft. wide and 30 ft. high, with a lean-to for the office and laboratory running the length of one end

of the building houses the plant (Fig. 1). Close by is the completely equipped sample-preparation laboratory. Regular samples are taken of the feed, the cleaned product and the refuse. Seven mining engineers, six chemists and one chemical engineer make up the technical staff at the Shenandoah plant; attached to the staff are a master mechanic, a pipe fitter, two plant operators and one clerk.

Fig. 2 is an isometric drawing of the equipment and its location in the plant. The quantity of feed delivered to the *wetting-out section* (numbered 1 in the illustration) is controlled by a sliding gate. After passing the gate the feed runs onto a steel shaking trough approximately 12 ft. long, 3 ft. high and 12 in. deep. This trough, suspended on wooden slats, is given a reciprocating motion by the usual eccentrics and wooden drive arms. It has a downward slope of about $\frac{1}{8}$ in. to the foot. Above the deck are three banks of fishtail sprays with ten fishtails to the bank. These sprays drive into feed passing down the trough, the material piling up in front of each bank. The horizontal motion of the trough pushes the material under each set of sprays,

Fig. 1—Ground plan of sink-and-float plant

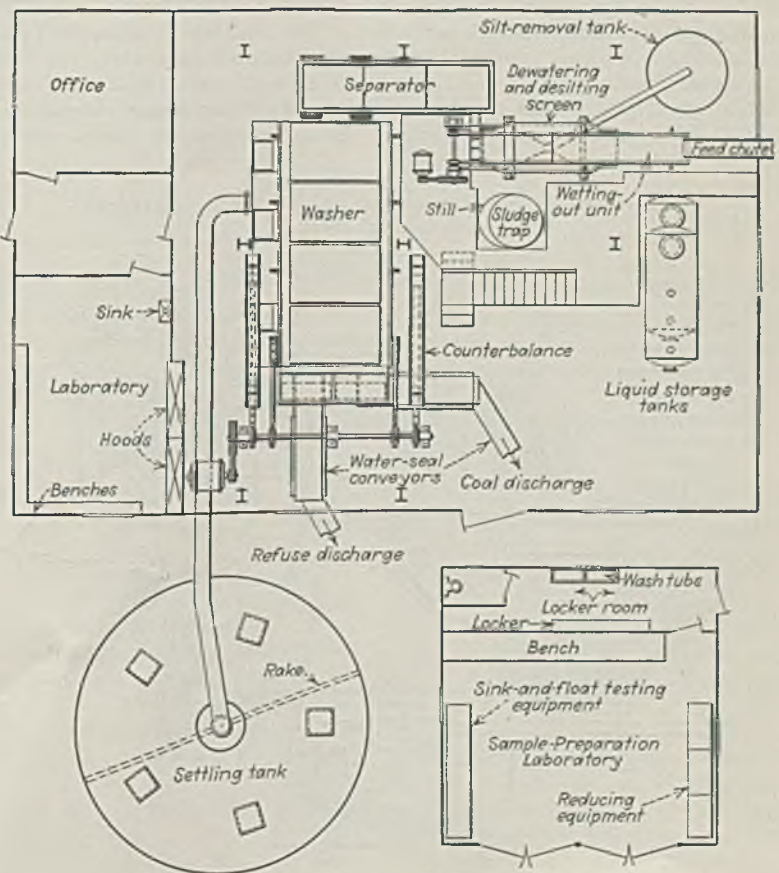

allowing the water to tear off the downstream side of the dam.

Thus each particle is scrubbed thoroughly by the sprayed solution of active agent after submersion in the solution of the same agent. The spray bank nearest the feed end of the deck operates at approximately 5 lb. pressure, the next downstream at 3 lb. and the third bank at 1 lb. pressure. Approximately 180 g.p.m. of active-agent solution is sprayed over and into the feed and the material remains on the deck approximately 13 seconds. As a result, the feed is immersed three times in a solution of active agent and is scrubbed three times with a driving spray of active-agent solution.

A 4x6-ft. dewatering screen (2) suspended on wood slats is driven by eccentrics with wooden arms from the same shaft driving the wetting-out deck. This dewatering screen acts as a counterbalance for the wetting deck. On it the liberated silt and most of the undersize is removed from the feed. The screen has a jacket with $\frac{1}{4}$ -in. round openings.

Fresh water for the system, approximately 12 g.p.m., is added through a bank of sprays half way down the screen. This water assists in removing the dirt, clay or silt liberated from the feed by the action of the active-agent solution. Tests show that, with the usual method of wetting—i.e., to spray or submerge in water and then dewater—the surface moisture on pea coal approximates 5 per cent. Treatment in a solution of active agent raises this moisture to about 6.5 per cent. This increase

probably is due to the active agent-water film completely surrounding each individual particle in the feed. This aqueous film apparently remains intact on the surface of the particles throughout the process.

Active-agent solution removed with the silt and make-up water through the dewatering-screen perforations passes to a conical settling tank. Here the silt is settled out of the solution, which then is brought to the proper strength by the addition of fresh active agent and is recirculated to the wetting-out deck.

Even though the mine-run product was scrubbed thoroughly in the breaker with fresh water, 10 to 15 lb. of silt and clay per ton are removed from the feed to the sink-and-float plant by the action of the wetting-out deck assisted by the active agent. No attempt is made to reduce the proportion of solids recirculated from the cone below 2 per cent, as these solids are exceedingly fine and are removed from the separator feed by the fresh-water spray on the dewatering screen deck. A slight quantity of water is added in excess of that actually required to wet the coal; this excess carries off a portion of the suspended solids—about 3 lb. per ton of coal—so that the active-agent solution never becomes a mud. A concentration of 0.01 per cent of starch acetate or tannic acid has proved a satisfactory active agent.

The separating chamber (3) is a steel box, approximately 18 $\frac{1}{2}$ ft. long, 3 $\frac{3}{8}$ ft. wide and 11 $\frac{3}{8}$ ft. high, in which two flight conveyors running in the same direction are placed one inside

the other. It contains a layer of parting liquid superimposed by a layer of water, each approximately 2 ft. in depth. The feed chutes from the dewatering screen into the separator protrude into the water to form a vapor seal. Chutes are arranged to distribute the feed evenly across the end of the machine in the water layer. As the material drops through the water it fans out onto the surface of the parting liquid.

Heavy particles immediately plunge through the interface of the parting liquid and water and sink to the bottom of the tank, where they settle on the outside, or sink, conveyor. The floats either remain at the interface or, after plunging into the parting liquid a short distance, return to the interface, where they are engaged by the inside, or float, conveyor. Middlings are trapped in the parting liquid.

Handling Sinks and Floats

The outside conveyor removes the sinks upward over a wedge-wire screen extending into the water layer; the inside conveyor carries the floats in like manner over a similar screen. These screens have 3-mm. openings. A V-shaped baffle plate to keep floats and middlings from passing onto the sink conveyor is placed between the conveyor lines with the point of the V pointing against the direction of flow of the parting liquid. The apex of the V can be raised or lowered to control the percentage of middlings in the floats or sinks.

Liquid pumped over and under this device by the conveyor flights passes through the wedge-wire screens and then is circulated around the outside of the separating chamber and returned to the chamber at the rear. The separated sinks and floats are moved continuously by the parting liquid from the portion of the chamber where the incoming feed enters the parting liquid. This eliminates rafting. Due to the rapidity of separation, the separating area required per ton of coal is exceedingly small. The Shenandoah installation has handled up to 100 tons of feed per hour with an effective separating area of only 2 sq.ft. of parting liquid.

Parting-liquid level is maintained by pumping used liquid from the used-liquid storage tank into the separator. This makes up for the 5 to 10 lb. of liquid carried out of the separator per ton of coal treated. The volume filled by parting liquid in the bottom of the separator is approximately 45 cu.ft. The water level is maintained by pumping a

Fig. 2—Isometric view of equipment and location in Shenandoah sink-and-float plant.

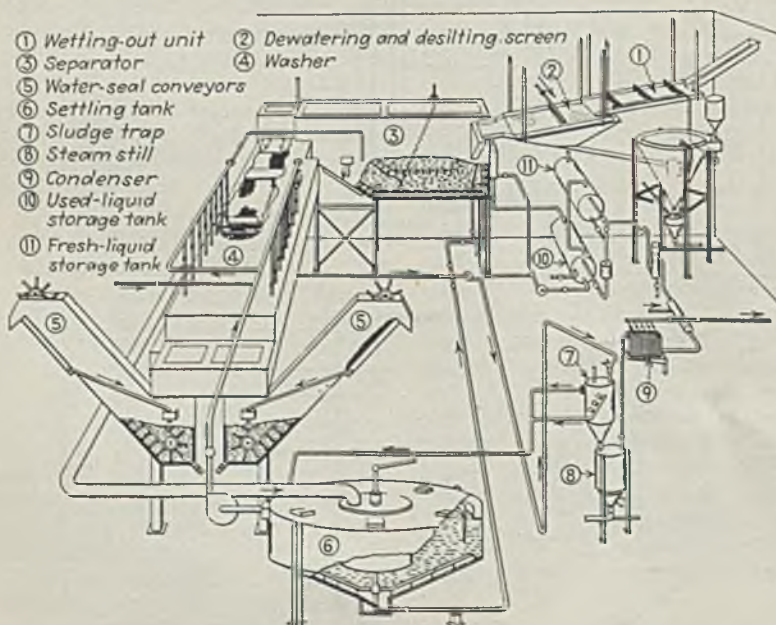

continuous stream into the separator from the settling tank, the excess passing over a weir overflow and back to the tank.

The washer (4) receives the sinks and floats after the sorting has been made and they are withdrawn from the parting liquid in the separator by the conveyors through the water layer. This tends to remove a large quantity of the entrained parting liquid. The two fractions are passed on to two shaking conveyors which are an integral part of the washer screen. This screen, approximately 20x8 ft., is suspended on wooden slats through a specially designed water seal and is driven by eccentrics. It is counterbalanced by two weights supported on wooden slats also driven by eccentrics. The screen is dressed with a perforated ($\frac{1}{8}$ -in. openings) steel plate which operates at approximately 132 r.p.m. and has a 4-in. stroke. As this screen is really a dewatering conveyor, the high speeds required in normal screening operations are unnecessary. A full-length partition in the middle of the screen keeps the floats from becoming contaminated with the sinks.

How Fishtail Sprays Act

Extending across each side of the screen are multiple, individually controlled sets of fishtail sprays. Each set has twelve nozzles pointing almost vertically downward so that the water sprayed tends to dam up the coal and refuse as they are conveyed along their respective sides of the screen. The horizontal motion of the screen pushes the coal and refuse under each set of sprays and allows the water to tear off the downstream side of the dam. Thus each individual particle is thoroughly scrubbed so that the entrained parting liquid, which has been kept away from the surface of the material by the action of the water placed on it by the active agent, can be recovered.

There is sufficient space between each set of sprays to permit a thorough dewatering from the previous wash. Immediately ahead of each set of sprays and hanging from the top of the washer housing is a baffle plate with a trough at its bottom to catch the splash from the upstream spray and carry the splash water and parting liquid off to the side of the housing. This is done so that the parting liquid which may be driven off the material being washed will not be splashed the full length of the washer housing and contaminate the washed product.

While ten sets of sprays were installed on each side of the washer

screen so that a variety of coals and minerals might be tested, operating experience on anthracite demonstrated that never more than five sets would be required to secure a minimum liquid loss with coal. These five sets are operated at a pressure of approximately 8 lb. per square inch and wash the sinks and floats with a combined total of 1,100 to 1,200 g.p.m. of recirculated water.

The water-seal conveyors (5) which receive the material after it has been thoroughly dewatered on the end of the washer screen are ordinary flight conveyors running in a boot so arranged that the feed from the washer screen is discharged into them through water, thereby forming an effective vapor seal. The sinks and floats are then conveyed to the refuse hopper and the final sizing screens in the breaker.

The settling tank (6) outside the building, is approximately 25 ft. in diameter, 12 ft. high, and has a conical

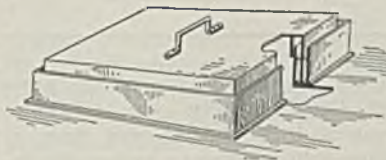

Fig. 3—Exterior view of water seal

ical bottom with approximately a 10-deg. slope. In the bottom of the tank is the usual form of rake for moving solids into the center of the cone. The weir box at the top runs completely around the tank. Concentric with this weir box is a seam gutter which keeps small droplets of parting liquid from passing over the weir. At intervals along the bottom of the gutter, pipes are led to a point near the tank bottom so that parting liquid caught in the gutter can run to the bottom of the tank and be kept out of the weir overflow.

Since the parting liquid itself has a high gravity, large droplets naturally settle to the bottom. The upward current in the tank carries some small droplets to the surface, where they immediately break and form a surface "slick" similar to that made by oil. This film finally becomes so thick that it contracts and breaks into droplets sufficiently large to settle to the tank bottom.

Degraded material is removed from the finished product through the washer screen and passes to the settling tank with the wash water. Droplets of parting liquid falling through the water in the tank carry down the small solid particles and

thus keep the percentage of solids in the recirculated water to the washer from the tank so low that it can be considered only a trace. Due to this self-cleaning action and the freedom from emulsification of the parting liquid when beaten into water, the settling tank can be made relatively small and operated continuously without building up a high percentage of mud or slime.

Capacity More Than Ample

Water for the washer is pumped from the settling-tank overflow by a centrifugal pump with a capacity of 3,000 g.p.m. at a 52-ft. head. As before stated, it was not found necessary to use this quantity of water nor as high a spray pressure. In fact, the whole washing system was more than twice as large from the standpoint of pumping equipment, settling tank, number of sprays, etc., as was required. The screen deck also proved of ample size for the tonnages handled.

A centrifugal pump moves the underflow mixture of parting liquid, silt and water from the settling tank through ordinary pipe lines to the sludge trap (7). This trap is a straight-sided tank 4 ft. in diameter and 6 ft. high with a conical bottom. It has a small overflow weir around the top and is fitted with fresh-water stingers at the bottom to break up bridging of the settled solids when they are discharged. The pump is so operated that the settling time in the trap is longer than in the main tank; this assures settling of the parting liquids and solids to the bottom of the trap. The entrained water flows over the weir and returns to the settling tank. When the trap is about half full of solids, the pump is stopped and, after five or ten minutes, the water remaining on top of the settled solids and parting liquid is decanted to the settling tank. Parting liquids and solids then are dropped through the bottom of the trap into a steam still immediately below. The pump connected with the underflow of the tank is subsequently started and the trap receives a new charge.

The steam still (8), which has the same dimensions as the trap, also has a conical bottom and is fitted with water stingers. Bottom and sides are steam-jacketed. The still has five steam nozzles in the bottom adjacent to the outlet. After sufficient charge has been dropped from the sludge trap to fill the still approximately three-fourths full of solids and parting liquid, the distillation is made. Steam consump-

tion varied from 1.1 to 5.8 lb. per pound of parting liquid recovered. Steam consumption varies with the composition of the charge to the still and the time required for stripping the last traces of parting liquid from the solids present. When distillation is completed, the solids discharged from the still contain 0.01 to 0.02 per cent parting liquid by weight.

Distillate from the still is passed through the usual form of *atmospheric drip-type condenser* (9), located on the roof of the plant. About 2.7 gal. of water is used for each pound of steam added to the still. The condensate is passed through a cooler and water separator. The recovered parting liquid is sent to the used-liquid storage tank and the water to the settling tank.

When running the plant at maximum capacity for the usual 8-hour shift, it was *unnecessary* to make more than one distillation, since, due to the action of the active agent, desilting was so complete and the quantity of parting liquid removed from the separator so small that only a very small quantity of material was collected in the settling tank. At no time did the silt distilled exceed 0.5 per cent of the clean coal produced. As the size of the material increased, the quantity of silt was substantially reduced.

Standard Construction Used

The general construction of the equipment used in the process is standard. All joints must be welded liquid- and vapor-tight. The material used is ordinary structural steel and plate with bronze-screen dressings in the separator and washer. All pieces of inclosed apparatus are vented to each other and there is a common vent for the whole plant. Vapor sealing is done with water seals on all equipment in which parting liquid is used. Water seals (see Fig. 3) consist of a U-shaped member not less than 6 in. deep filled with water; the lid is so constructed that its edge sits in the water, thereby forming the seal. This construction eliminates the necessity for bolts, toggles and other common methods for holding lids and covers on equipment to keep them vapor-tight.

There are two reasons for the water seal: (1) The necessity of preventing the escape of the parting-liquid vapor, as all such liquids are more or less volatile and the losses resulting if the apparatus is not sealed would make the process inoperable from a commercial stand-

Table I—Breakdown of Losses per Ton of Cleaned Coal

Feed and Production		Tons	
Feed (run-of-mine pea coal)...		3,090	
Coal produced		2,445	
Refuse		611	
Silt removed in wetting section.		18	
Silt discharged from still.....		16	
Operating Losses			
Pounds	Ounces per ton Cleaned Coal	Per Cent of Over-all Loss	
Loss on coal.. 796	5.2	44.5	
Loss on slate. 120	0.8	6.7	
Distillation loss 286	1.9	15.9	
Saturated water, vapor loss, etc....			
53	0.3	2.9	
Total operating loss	1,255	8.2	70.0
Clean-up Losses			
Settling tank full of saturated water. 220	1.4	12.2	
Additional loss in pumping out settling tank	197	1.3	11.0
Vapor losses.. 14	0.1	0.8	
Total clean-up losses	431	2.8	24.0
Unaccounted-for Loss			
Total unaccounted for. 107	0.7	6.0	
Over-all Loss			
Over-all loss..1,793	11.7	100.0	

point; (2) the toxicity of the parting liquids. They, like all halogenated hydrocarbons, are toxic if taken into the human system by inhalation, absorption through the skin or otherwise. At high temperatures they tend to decompose with the formation of toxic compounds.

Potential health hazards involved in the operation and maintenance of the equipment can be eliminated if proper precautions are taken to prevent exposure of humans to parting liquids or their vapors, and exposure of these materials in either liquid or vapor form to high temperatures, such as occur in open flames and electric-welding arcs.

Principal safety precautions taken at the Shenandoah plant are: Construction of the entire system is liquid- and gas-tight. Water seals

are provided to prevent the escape of vapors from the equipment. To eliminate the potential hazard involved if workers enter the equipment for inspection or repairs, means are provided to replace with fresh air the air in the machinery, which, of course, has become nearly saturated with the heavy parting-liquid vapors. *It is extremely dangerous to enter the machinery unless this precaution is taken.*

Safety Precautions Employed

All pockets, sumps or low places are ventilated to prevent the accumulation of the heavier-than-air parting-liquid vapors in such places. To prevent possible absorption of these toxic materials into the system through contact of the skin with parting liquid, all surfaces are washed with water and kerosene to remove even minute traces before any repair work is done. This same precaution also is taken before a torch or welding arc is applied to any surface to prevent subjecting the liquid to high temperatures. The small quantity of parting liquid which may be on the material leaving the plant introduces no health hazards because it does not remain on the material. Fire hazards are nil, as the halogenated hydrocarbons are non-flammable.

Parting-liquid loss per ton of feed was determined by making several quantitative runs. The plant was first completely emptied of all saturated water, parting liquid and active-agent solution. On recharging, actual weights were kept of the parting liquid charged into the separators and used-liquid storage tank. At the end of each run all the available free liquid was removed from the equipment and weighed. A typical breakdown of the losses is given in Table I. The clean-up loss of 2.8 oz. per ton would be non-recurring in regulator operation, since it would be

Table II—Condemned Coal, May 20, 1936, to April 12, 1937

Date	Number of Cars	Size	Reason
5/20/36	2	Pea	Oversize
6/18/36	1	Nut	Flat coal (appearance)
6/23/36	3	Nut	Undersize
6/26/36	3	Nut	Slate and bone *
6/29/36	1	Nut	Light bone and flats *
6/30/36	1	Nut	Flat coal (appearance)
7/14/36	2	Nut	Flats and rock *
7/24/36	2	Pea	Rock
7/31/36	1	Pea and nut	Bone (appearance) *
8/17/36	1	Pea	Yellow, light-gravity rock *
8/29/36	1	No. 1 Buck.	Too-high ash
9/1/36	1	Rice	Too-high ash
10/22/36	1	Pea	Light round stones *
10/24/36	1	Pea	12-per cent sinks
11/27/36	1	Pea	Wood and rusty coal
4/8/37	1	Pea	Light stones *
4/12/37	3	Pea	Dirt and light stones *
	193		

* Mainly floats on 1.75 sp. gr. zinc chloride.

CHESTNUT AND PEA-COAL REFUSE

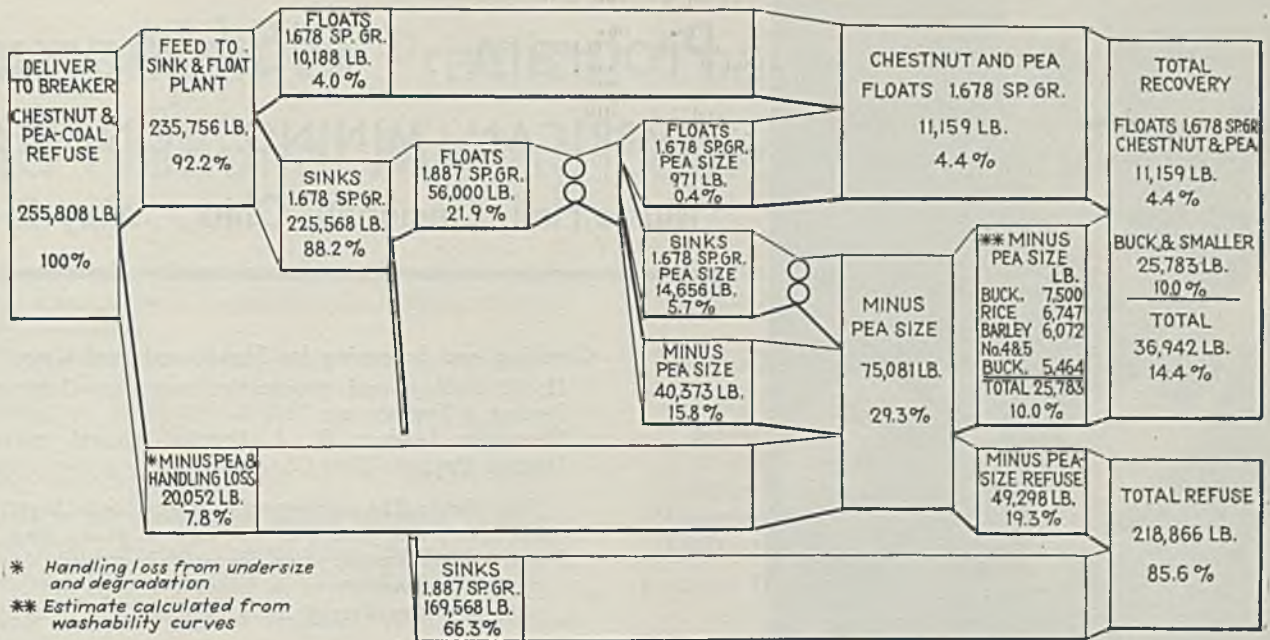

Fig. 4—Recovery of merchantable coal from nut-and-pea refuse

unnecessary to remove the saturated water from the settling tank, the vapor losses through venting of the equipment would be unnecessary, and the loss due to pumping out the settling tank would be eliminated.

Operating Loss Only 8.9 Oz.

Actual operating loss for the run of Table I was 8.9 oz. (11.7 oz. minus 2.8 oz.) per ton of cleaned pea coal. Parting-liquid loss increases as the size of the particles sorted decreases, and decreases as the particle size increases. No set formula has been derived to calculate this variation in loss. The highest loss experienced in the operation of the Shenandoah plant was for rice—12.4 oz. per ton of cleaned coal.

Approximately 20,000 tons of material yielding 14,754.91 tons of cleaned coal has been passed through the Shenandoah plant. Out of 295 railroad cars (50-ton capacity) loaded with products of the plant, only 19½ cars (see Table II) were condemned and only five cars were condemned for material which should have been extracted by the process. Two of these—the cars condemned Aug. 29 and Sept. 1—were separated on parting liquid having a specific gravity too high, due to the effect of the water film placed on them by the active agent. This material should not have been put through the plant without changing the gravity from the previous run. The other three cars were loaded while making capacity tests for the separator.

Very careful check was kept on the refuse delivered from the plant from the standpoint of floats which should have been in the merchantable or finished product, but only once during the operation did these floats exceed 1 per cent of the sinks when separated on a zinc-chloride solution set at the specific gravity at which the parting liquid was cutting in the separator.

A series of tests were run on the mixed chestnut-and-pea refuse from another breaker. This refuse had been cleaned twice—once in the original operation and once in a rock jig prior to being forwarded to the Shenandoah plant. Fig. 4 shows the results obtained when the material was put through the sink-and-float system. The recovery of merchantable material from this refuse by first cutting at 1.67 sp. gr., then cutting the sinks at this gravity on a 1.887 sp. gr. to remove all high-ash material, and, after this, crushing the low-ash middlings and re-treating them on a 1.67 sp. gr. speaks for itself.

The range of sizes which can be handled in one separation depends on the quality of concentrate desired and the shape of the particle treated. As previously explained, thorough scrubbing of all particles was necessary to remove the parting liquid after separation. Obviously, parting-liquid loss would be excessive if 4-in. flats were separated with ½-in. round particles, as a large flat could easily cover a ½-in. particle. Satisfactory washing is ob-

tained with a size ratio of 4:1 provided there is not a large number of flat pieces of the upper size in the feed.

Practical Scope of Process

In practice, a mixture of chestnut, pea and buckwheat were satisfactorily separated provided the ash limit for the cleaned buckwheat was higher than that for chestnut, as the water film lowers the apparent density of the buckwheat in the parting liquid more than the density of the chestnut. Furthermore, egg, stove and chestnut were cleaned at one time. There are, however, certain practical limitations to the commercial process. The machinery required to handle plus 6-in. material probably would be so large that it would be uneconomical. There is nothing, however, to prohibit treating plus 6-in. material if there is any real advantage in so doing.

Both the possibilities and the limitations of the sink-and-float process described must be carefully considered when contemplating its commercial applications. In brief, the process is applicable to coal and to all other minerals which can be freed from their gangue or from each other in sizes plus 8-mesh Tyler standard screen scale. The process may be used on run-of-mine feed or for recovering the values in tailings or refuse delivered from existing plants. It also may be used as a preliminary concentrator or rougher-out ahead of other processes.



R. L. IRELAND, JR.

Program . . . 15th Annual AMERICAN MINING CONGRESS

Music Hall, Cincinnati, Ohio . . May 2-6

MONDAY • MAY 2 • MORNING

Chairman: Julian D. Conover, secretary, American Mining Congress.

*Introducing—*Howard I. Young, president, American Mining Congress.

E. J. Newbaker, vice-president, Berwind-White Coal Mining Co., and chairman, Advisory Council, Coal Division.

R. L. Ireland, Jr., president, Hanna Coal Co., and national chairman program committee.

William E. Goodman vice-president, Goodman Mfg. Co., and chairman, Manufacturers' Division.

Methods of Breaking Down Coal at Face

C. F. Connelly, general manager, Kemmerer Gem Coal Co.

Choice of Cutting Bits and Chain Lacing

W. D. Ingle, Jr., general superintendent, Ingle Coal Co.

Mine Haulage Road Construction and Maintenance

E. H. Jenks, mining engineer, Rochester & Pittsburgh Coal Co.

MONDAY • MAY 2 • AFTERNOON

Coal Washing, Crushing and Blending

E. C. Carris, in charge of preparation department, Island Creek Coal Co.

Practical Limits of Slate Removal

D. B. Baird, chief inspector, Philadelphia & Reading Coal & Iron Co.

Methods of Drying Washed Coal

K. R. Bixby, general manager, Midland Electric Coal Corporation.

Discussion Leader, T. W. Guy, consulting engineer, Charleston, W. Va.

Crushing and Screening for Stoker and Fuel Uses

H. F. Hebley, coal preparation engineer, Commercial Testing & Engineering Co.

Discussion Leader: W. J. Borries, general manager, Dawson Daylight Coal Co.

Play Time: The evening will be Jamboree Night, when informal festivities will include group singing, balloon dances, prize dances, "shag" and "big apple" demonstrations in which all may participate; also the Merriell Abbott dancers.

TUESDAY • MAY 3 • MORNING

New Features in Haulage Equipment

(a) Automatic Mine-Car Couplers

Peter F. Loftus, consulting engineer, Pittsburgh, Pa.

(b) Hydraulic Brakes on Mine Cars

F. K. Day, general superintendent, and E. P. Selby, mine superintendent, Pardee & Curtin Lumber Co.

(c) Mine Locomotives

Carl Lee, electric engineer, Peabody Coal Co.

Newest Developments in Cutting-Machine Practice

Paul Weir, mining engineer, Chicago.

New Equipment and Methods in Strip Mining

Ira Clemens, president, Commercial Fuel Co.

Discussion Leader, T. G. Gerow, chief engineer, Truax-Traer Coal Co.

Underground Water in Northern Anthracite Field

J. F. K. Brown, assistant general manager, and H. H. Otto, mining engineer, Hudson Coal Co.

Discussion Leader, Paul F. Brown, manager, Splash Dam Coal Corporation.

TUESDAY • MAY 3 • AFTERNOON

Problems to Be Considered Before Installing Conveyors

R. G. Pfahler, mining engineer, Berwind-White Coal Mining Co.

Discussion Leader, R. L. Wilhelm, superintendent, New Jellico Coal Co.

Problems in Gathering, Loading and Moving Conveyor Equipment

M. A. Sharp, mining engineer, Union Pacific Coal Co.

Discussion Leader, F. G. Smith, assistant general superintendent, Sunday Creek Coal Co.

Power Distribution for Conveyor Installation

L. C. Selnerr, division manager, Consolidation Coal Co.

Discussion Leader, H. P. Musser, West Virginia Engineering Co.

Convention of Practical Coal Operating Men and National Mining Equipment Exposition

Mining Methods in 24-In. Seams

W. C. Chase, general superintendent, Alabama By-Products Corporation.

Play Time: Guests will forget their cares and troubles in the Pavillon Caprice of the Netherland Plaza as "Waikiki Night" is featured.

WEDNESDAY • MAY 4 • MORNING

Problems to Be Considered Before Installing Loaders

D. D. Wileox, general superintendent, Superior Coal Co.
Discussion Leader: George Schultz, Liberty Fuel Co.

Cleaning and Degradation Problems With Mechanical Loading

Charles B. Baton, vice-president, Baton Coal Co.

Transportation Problems With Mechanical Loading

J. W. Woomer, chief mining engineer, Hanna Coal Co.

Problems in Mining Thin Seams With Mechanical Loading

William Cunningham, superintendent, Linton-Summit Coal Co.

WEDNESDAY • MAY 4 • AFTERNOON

Use of Motion Pictures in a Safety Program

C. R. Stahl, division superintendent, Koppers Coal Co.

Safety Training for Employees

John Lyons, safety engineer, Bell & Zoller Coal & Mining Co.

Reducing Haulage and Machine Accidents

David W. Jones, superintendent, Princeton Mining Co.

Safety Contests (intra-company)

C. E. Young, personnel manager, Wheeling Township Coal Mining Co.

Play Time: This will be "Jack Dempsey Night," featuring two-fisted boxing and wrestling bouts, with the former champion as referee.

THURSDAY • MAY 5 • MORNING

Equipment Repairs and Shop Practice

V. D. Pickleshimer, master mechanic, South-East Coal Co.
Discussion Leader, R. S. Adams, general superintendent, Clinchfield Coal Corporation.

Underground Power Distribution

C. C. Ballard, master mechanic, New River Co.
Discussion Leader, Andrew Hyslop, Jr., electrical engineer, Snow Hill Coal Corporation.

Shaft-Sinking Methods

Percy G. Cowin, Salmon & Cowin, Inc.
Discussion Leader, Fred Nesbit, vice-president, Boulder Valley Coal Co.

Modern Ventilating Installations

William Norris, Jr., safety director, Carter Coal Co.

THURSDAY • MAY 5 • AFTERNOON

Successful Adjustment Between Management and Employees

J. R. Sharp, director of public relations, Philadelphia & Reading Coal & Iron Co.

Discussion Leader, M. M. Moser, vice-president, United Electric Coal Cos.

Personnel Training

A. D. Sisk, safety director, Big Sandy-Elkhorn Coal Operators' Association.

Discussion Leader, C. R. Garrett, general superintendent, American Smelting & Refining Co.

Mine-Official Responsibility in Personnel Management

Speaker to be announced.

General floor discussion.

Play Time: In the evening the annual speechless banquet will be held; also acts by radio and stage artists and the Merriel Abbott dancers.

FRIDAY • MAY 6 • MORNING

Exhibitors' day—no convention sessions—list of exhibitors on p. 97.



TRACTOR-TYPE DIESELS

+ Selected for Driving D.C. Generator

In Modernization of Ohio Truck Mine

TWO tractor-type diesel engines were selected for the generator drive of a new power plant put into service Feb. 23 to replace the antiquated steam unit at the truck mine of the Irish Rock Coal Co. in the Crooksville field of Muskingum County, Ohio. The mine was opened fifteen years ago, but the present owner, C. B. Aston, of McConnellsville, Ohio, has modernized the plant during his two years of proprietorship and now has efficient equipment to produce 175 tons in seven hours when the market demands that quantity. Elimination of the steam plant cut the job of fireman and engineer from the mine payroll.

The engines, made by the Caterpillar Tractor Co., are six-cylinder vertical in-line units and are rated 125 hp. maximum. Each is complete with its two-cylinder starting gasoline engine and fan-cooled radiator. The gasoline engine is attached to the side of the diesel in a position so that the crankshaft is direct connected to the starting pinion, which is meshed to the diesel flywheel by hand and also is engaged by a lever-actuated clutch. The gasoline engine is cranked by hand and has magneto ignition. Thus, no battery is required.

Two Engines Drive Generator

Through V-belts, both engines drive one 150-kw. 275-volt generator. Engine speed is 800 r.p.m. and generator speed is 1,100 r.p.m. V-belt drive-shaft extensions from the engines are supported in Dodge-Timken bearings and are equipped with Dodge friction clutches. Thus one or both engines can be operated to drive the generator and one engine can be started by power from the

other if the former is warm. Crankshafts and shaft extensions are tied together by flexible couplings.

Engines complete with the extension shafts are mounted on welded steel bases which in turn are bolted to slide rails cast into the concrete foundations. This provides for adjustment to maintain correct belt tension. Because the generator is positioned between the two engines and belt tensions are kept as nearly equal as possible no outboard bearing is required even though the pulley to accommodate the two drives of seven belts each necessarily has a wide face. The generator is a General Electric Type RO-38 and was purchased second-hand. The

Irish Rock truck mine is a slope operation on the bank of the Muskingum River but is not equipped for barge loading.



water-cooling systems of the two engines are entirely separate and self-contained. In cold weather the water is mixed with Super-Pyro antifreeze.

The 18x24-ft. floor of the power-plant building constitutes the only foundation for the units, which weigh approximately three tons each. This floor is a reinforced concrete mat 18 in. thick set on the loose gravel found in that locality. This low-cost foundation, compared to that which was considered necessary for a single heavy-type diesel built for stationary duty, was one of the factors influencing the selection of the tractor-type engine. However, the lower first cost of the two diesels, as compared to one stationary-type engine, was the principal reason for installing the tractor type. Total investment to construct the new plant, including concrete floor and metal-clad wood building, was approximately \$8,000.

Seam Reached by Slope

Although the mine tippel is within 200 ft. of the Muskingum River and only $6\frac{1}{2}$ miles south of the Philo power plant, which gets most or all of its fuel by river barge, the equipment is designed for truck loading only. The tippel stands beside concrete-surfaced State Highway No. 77 and is 18 miles south of Zanesville. The coal—No. 7 seam—is 48 in. thick and lies 50 ft. below the level of the highway. It is reached by a slope the portal of which is 12 ft. above the highway and thus not vulnerable to floods of moderate proportions.

The tippel consists of four 110-ton truck-loading bins above which are the track scale, cross-over dump,

slope hoist, a 3x7-ft. double-deck screen, a 3x30-ft. belt-type conveyor boom reaching from screen to lump bin and a 17-ft. drag conveyor from screen to egg bin. The function of the belt boom is to carry the lump coal down to the bottom of the bin or to the coal level. Sizes made are 3-in. lump, 3x1 $\frac{1}{4}$ -in. egg, 1 $\frac{1}{4}$ x $\frac{3}{8}$ -in. stoker and $\frac{3}{8}$ x0-in. slack.

The screen, which is a motor-driven vibrating or high-speed shaking unit, was made by the Nelsonville Electric Co. The slope hoist handles 500 ft. of $\frac{3}{4}$ -in. rope and is driven by a 20-hp. motor. Approach trestle, tippie and bins are built from resawed lumber salvaged from trestles of a discontinued branch line of the New York Central R. R. Corrugated galvanized metal is used for roof and sides except that the bin sides are not thus clad.

Mine Advanced a Half Mile

Mining equipment consists of 70 plain-bearing wooden cars averaging 2,780 lb. of coal each, one Goodman 12A shortwall cutter, one Jeffrey 35B shortwall and one 5-ton trolley locomotive. Three ponies do the gathering. Development has progressed to a point one-half mile distant from the slope bottom. Neither top nor bottom is taken on headings and the mining is by the block system with retreat-pillar recovery. Undercutting is done on the loading shift and pellet powder is used for shooting. Ventilation is supplied by a centrifugal fan driven by a 10-hp. d.c. motor. Steel rails of 25-lb. and 16-lb. sizes are used on mains and headings, respectively, with wood rails in rooms.

Territory available to the mine consists of 125 acres held in fee and 125 acres under lease. Although the mine is equipped with a 10-ton truck scale 24 ft. long, the largest semi-trailer trucks which come for coal must be double-weighed—that is, the tractor first and then the rear wheels of the trailer. This past winter, there were times when for several days in succession the truck loading from the bins exceeded 200 tons per day.

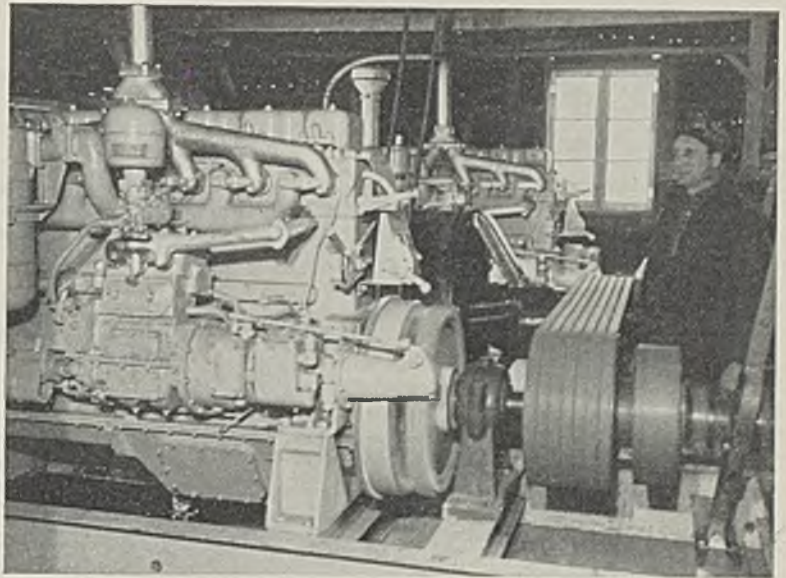

Two 125-hp. tractor-type diesels driving one 150-kw. generator replaced an antiquated steam plant. C. B. Aston, mine owner, stands at the right.



Below the tippie, which has a shaker screen, are four 110-ton bins. Slack in the right foreground was thus stored because it would not sell at the minimum prices set by the code.

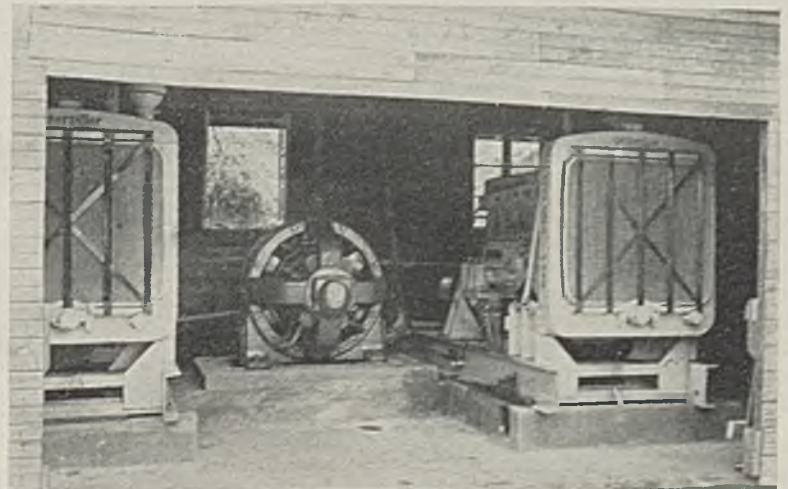

Engines are complete units with gasoline-engine starters and fan-cooled radiators.

INCLINE ROPE STRESSES

+ How They May Be Computed

Based on an Assumed Condition

By FRANKLIN P. CLARK

*Buffalo District Sales Manager
Wickwire Spencer Steel Co.*

REGARDING the method of computing rope stresses on inclined slopes and planes, help may be found in textbooks, but to what is found there additional reasoning must be applied, which information and examples in this article will supply. Not only the magnitude of the individual stresses but also the direction of the various forces should be ascertained. The following problem is suggestive, as several computations must be made to determine the point of maximum total stress and its value. In the illustration will be found a cross-section of the incline, which is located underground. The rope is attached to the front end of the loaded trip or the rear end of the empty trip. It passes under a sheave at the head of the incline and up a 190-ft. borehole to the surface, where it bends over a sheave and travels to the hoist, 149 ft. The conditions assumed are contained in Table I.

Fatigue With Small Sheaves

At present, eighteen cars are pulled up the incline on each trip. The management, however, desires to increase the load, if it can be done without using too small a factor of safety. The weight of the rope is that of 6x17, 6x19, 6x21 or 6x25 ropes, as the sheave diameters are too small to permit of the use of a 6x7 rope successfully, this being proved by the fact that a 6x7 rope, when previously used on this incline, early developed fatigue breaks. The weight of a 1½-in. rope of the stranding given is 2.03 lb. per foot.

Flatt Angle—Before studying the other stresses, the flatt angle should be examined to see whether it would bring a stress on the rope or whether its magnitude would influence the de-

cision as to the construction of the rope. The tangent of this angle = (half width of drum ÷ (distance, center line of drum to center line of head sheave) = $2.25 \div 149 = 0.0151$. Thus, the flatt angle is only 52 minutes.

No angle less than 1½ deg. would make a change in the type of rope necessary. A greater angle would require that a construction be chosen that would withstand the abrasion which develops when the section of the rope being laid on the drum rubs against the adjacent rope in the same layer.

The drum is 6 ft. in diameter and smooth-faced, not grooved, and in such cases the best and usual practice is to keep a complete layer of rope on the drum at all times to form grooves in which the succeeding layer of rope may lie.

With a drum 6 ft. in diameter,

Table I—Slope Equipment Details

Diameter of drum (ungrooved), ft.	6
Width across drum face, ft.	41
Distance, center line of drum to center line of head sheave, ft.	149
Vertical depth of borehole, ft.	190
Speed of rope in feet per minute.	540
Number of layers of rope on drum.	4
Period of acceleration, sec.	20
Period of deceleration, sec.	15
Diameter, bicycle-type sheaves, ft.	6
Diameter, wood rollers, in.	8
Diameter, steel rollers as turns, in.	16
Roller spacing, ft.	30
Roller diameter at bottom, in.	6
Diameter of rope (limited by existent grooves in sheaves), in.	1½
Total length of rope, ft.	8,900
Weight of rope per foot of length, lb.	2.03
Weight of empty car, lb.	2,700
Capacity of car, lb.	5,000
Total weight, loaded car, lb.	7,700
Number of cars in trip.	18
Total weight empty-car trip, lb.	48,600
Total weight loaded-car trip, lb.	158,600
Length of car, about, ft.	32
Length of trip, about, ft.	105

one complete lap would be 6 ft. x 3.1416, or 18.85 ft. As there are 45 laps of rope across the face of the drum, the number of feet of rope on the drum is 45 x 18.85, or 848.25 ft. The total footage of rope is, therefore, length on drum + length from drum to head sheave + length down borehole + inclined length of plane (see Table I) = 848.25 + 149 + 190 + 7,344, or 8,531.25.

Provide Length for Repairs

This rope has to be socketed on the trip end and, because the vibration in a rope, socketed at one end, eventually causes fatigue breaks near that end, it is advisable from time to time to cut off a section of the rope and resocket it. To provide sufficient rope for this purpose, as well as for an occasional cut, in case the cars run over the rope and damage it severely, another 368.75 ft. of rope is included, thus providing some additional rope at the foot of the incline so that the necessary repairs can be made without splicing the rope, for even a good splice is only about 90 per cent efficient. The total length, therefore, is 8,531.25 + 368.75, or 8,900 ft. of rope.

A. Stresses During Acceleration Period at Foot of Incline When Hoisting Loaded Trip—Normally the trip is made up at the foot of the incline and is accelerated quite largely before the incline is reached, but sometimes a car leaves the rail or, for some reason, it is necessary to stop the hoist, after which the trip has to be accelerated on the incline and not on the level. Hence, it is assumed here that the cars have

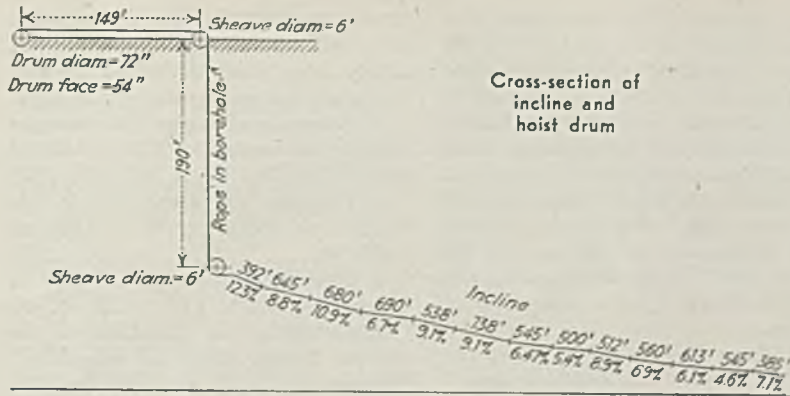

Therefore,

$$F = \frac{(\text{weight of trip} + \text{weight of rope}) \times 0.7}{32.2}$$

$$= \frac{(138,600 + 15,383) \times 0.7}{32.2}$$

= 3,348 lb.

That is, stress due to acceleration = 3,348 lb. (3)

d. Stress due to rope friction. Authorities declare that rope friction equals 5 per cent of the horizontal component of the rope, which is equal to weight of rope multiplied by cosine of inclination. On such inclinations as are found on this incline the cosine is so near unity that, for simplicity, unity will be assumed as the value. The error resulting from this assumption will be small and will leave a margin favorable to safe operation. Thus, the friction will equal length of rope \times weight of rope per foot \times frictional factor = $7,239 \times 2.03 \times 0.05 = 14,695 \times 0.05 = 735$ lb. (4)

Car Friction Allowance

e. Stress due to car friction. Car friction is assumed as 50 lb. per ton in this case, because the cars have sleeve bearings, a quantity of loose coal is found on the tracks and other conditions are found unfavorable to haulage. This figure is large enough to keep the computation on the safe side. In other cases, 20 or 30 lb. per ton may be regarded as a better estimate when the equipment in use and its condition is considered. Hence, stress due to car friction = $138,600 \times 50 \div 2,000 = 3,465$ lb. . . (5)

f. Weight of rope in borehole — 190 ft. of rope \times 2.03 lb. per ft. = 386 lb. (6)

Thus, the magnitude of the various stresses, all of which are needed to pull the trip with the needed acceleration on the first section of the incline, will be as in the following

traveled until all have entered the incline; thus the rope extends the full length of the incline less the length of the trip, which is 105 ft. = $7,344 - 105 = 7,239$ ft. Speed on incline after acceleration is 840 ft. per minute, or 14 ft. per second. Thus, mean speed, during acceleration period, will be 7 ft. per second. As the entire acceleration period is 20 seconds, the distance over which the acceleration will occur will be 140 ft. Hence, the cars may still be accelerating after all of them are on the incline.

Computation of Stresses

a. As the stress due to the weight of the loaded cars on the incline = the load \times sine of the inclination, which in Table II is listed as 0.0709, this stress will equal $138,600 \times 0.0709 = 9,841$ lb. (1)

b. Table II shows sines of inclination of the sections of the incline from the foot up. The stress due to the weight of the rope = sine of inclination multiplied by weight of rope for each section, and the gross stress equals the sum of these several items as listed at the foot of column (6), which is 1,168.12 lb. However, at the instant under consideration, the rope extends only to a point 105 ft. from the bottom of the incline. As 105 ft. is on an inclination having a sine of 0.0709 and as 105 ft. of rope weighs 105×2.03 , or 213.15 lb., the figure 1,168.12 lb. will be too large by $213.15 \times 0.0709 = 15.11$ lb. Consequently, the stress due to the weight of rope will be about 1,153 lb. (2)

c. The force necessary to accelerate the load from a state of rest to a velocity of 840 ft. per minute—the speed of the trip—is computed by the formula $F = Ma$, where F = the force in pounds and M = total weight of cars, coal and rope, from the end of the cars to the drum, divided by 32.2, which is the acceleration at sea level, due to gravity, in feet per second in one second, and a

is the acceleration of the trip in the same units. The entire rope, including that wound on the drum, has to be accelerated as well as the head sheaves, rollers and drum, but the rope on the drum is carried around by it and the drum is accelerated by the driving forces and, hence, the acceleration of drum and rope on drum does not bring a strain on the hoisting rope.

However, the needed acceleration of sheaves and rollers adds to the acceleration stresses on the rope. As these last two items are not large, they will be disregarded. However, it will not be safe to disregard the weight of the rope of which 7,239 ft., as stated, hangs down the incline. 190 ft. hangs vertically from the depth of the borehole, and 149 ft. extends from center line of head sheave to center line of drum. This length is 7,578 ft., and the weight is $7,578 \times 2.03 = 15,383$ lb.

Acceleration Adds Stress

In the equation $F = Ma$; a , as stated, = acceleration in feet per second in one second = (final velocity in feet per second) \div (acceleration time in seconds). The velocity is 840 per minute, or 14 ft. per second, and the acceleration time is 20 seconds. Then $a = 14 \div 20 = 0.7$ ft. per second in one second.

Table II—Gradients of Incline, Rope Weight and Stress Due to Weight of Section of Rope by Sections

Distance at Gradient (2)	Gradient of Section Per Cent	Inclination of Section Deg. and Min.	Sine of Inclination of Section	Weight of Rope, Lb. of Section	Product, Lb. (4) x (5)
(1)	(2)	(3)	(4)	(5)	(6)
Foot	386	7.1	4° 04'	0.0709	784
	545	4.6	2° 38'	0.0459	1,106
	613	6.1	3° 29'	0.0608	1,244
	590	6.9	3° 57'	0.0689	1,127
	512	8.9	5° 05'	0.0886	1,039
	500	5.4	3° 05'	0.0538	1,015
	545	6.47	3° 42'	0.0645	1,106
	738	9.1	5° 12'	0.0906	1,498
	538	9.1	5° 12'	0.0906	1,092
	690	6.7	3° 50'	0.0665	1,401
	650	10.9	6° 13'	0.1083	1,380
	645	8.8	5° 02'	0.0877	1,309
Top	392	12.3	7° 01'	0.1222	796
	7,344				1,168.12

The last column (6) shows the stress on rope due to weight of each section on incline.

tabulation. As all the forces oppose the pulling of the trip and rope up the incline, the stresses must be added.

Rope Stresses in Trip Which Has Just Completely Arrived on Bottom Section of Incline but Is Still Being Accelerated

a. Stress due to weight of loaded cars on incline.....	9,841 lb.
b. Stress due to weight of rope on incline.....	1,153 lb.
c. Stress due to acceleration.....	3,348 lb.
d. Stress due to rope friction on incline.....	735 lb.
e. Stress due to car friction.....	3,465 lb.
f. Stress due to weight of rope in borehole.....	386 lb.
	18,928 lb.
	= 9.464 tons

B. Stresses When the First Car Reaches Top of Incline—At the top of the incline, the load is decelerated in 15 seconds. As the maximum speed is 14 ft. per second, and, after deceleration, 0 ft. per second, the average speed is 7 ft. per second, and in 15 seconds the trip will travel 105 ft., which happens to be the length of the trip.

- a. Stress due to weight of loaded cars on incline = $138,600 \times \sin 7 \text{ deg. } 1 \text{ min.}$
 $= 138,600 \times 0.1222 = 16,937 \text{ lb. (1)}$
- b. Stress due to weight of rope on incline = 0 lb.....(2)
- c. Decrease of stress due to deceleration. Here, the rope length between top of incline and center line of drum is all that has to be considered, namely, 149 ft. + 190 ft. vertical length, or 339 ft.

Deceleration Lightens Load

This is a decrease in stress, because the cars are being helped up the incline by their own inertia and, in that degree, do not have to call on the rope to help them up. In fact, if the deceleration were speedy enough, the cars would actually push the rope up the incline.

$$M = \frac{138,600 + 339 (2.03)}{32.2}$$

$$= 4,326 \text{ lb.}$$

$$a = 14 \div 15 = 0.9333$$

F = decrease of stress due to deceleration, 4,037 lb....(3)

- d. Stress due to rope friction on incline, 0 lb.....(4)
- e. Stress due to car friction, 3,465 lb.(5)
- f. Stress due to weight of rope in borehole, 190 ft. of rope $\times 2.03 \text{ lb. per ft.} = 386 \text{ lb.(6)}$

In this case (1) (2) (4) (5) and (6) are added and (3) subtracted, giving an algebraical total = $16,937 + 3,465 + 386$ (or $20,778$) $- 4,037 = 16,751 \text{ lb.} = 3.376 \text{ tons.}$

C. Stresses When the Rear Car of an Empty Trip Is Just 35 Ft. Clear of the Head of the Incline and the Cars Are at Point of Ceasing to Accelerate—As the rope accelerates in 20 seconds and the average speed during the acceleration period is 7 ft. per second, the acceleration does not end until the front car is 140 ft. over the top of the incline. As the trip is 105 ft. long, the rear car will be just 35 ft. clear of the head of incline.

- a. Stress due to weight of empty cars on incline = $48,600 \times \sin 7 \text{ deg. } 1 \text{ min.} = 48,600 \times 0.1222 = 5,939 \text{ lb.(1)}$
- b. Stress due to weight of rope on incline = $35 \times 2.03 \times 0.1222 = 9 \text{ lb.(2)}$
- c. Decrease of stress due to acceleration $F = Ma =$

$$\frac{48,600 + (8,900 \times 2.03)}{32.2} \times \frac{14}{20}$$

$$= 1,449 \text{ lb.(3)}$$

It will be noted the entire length of the rope (8,900 ft.; see Table I) is included in this computation because the length of rope which is always kept on the drum has to be accelerated as well as the length that is pulled down the incline by the dropping of cars. Most of the rope is on the drum, but it has to be accelerated and has to pull the drum around with it and perhaps may have also to actuate the driving mechanism in the case of steam-driven equipment. In consequence, the weight of the drum, as well as the weight of the head and foot sheaves, and of all parts moved by the travel of cars should be considered in figuring this acceleration stress, but, for reasons now to be explained, they are excluded from the calculation.

Drum Weight Immaterial

Though large, these items are omitted as immaterial, for these stresses due to acceleration cannot be as great as the sum of the stresses by which they are set in operation; in other words, the stress due to weight of empty cars and rope cannot exceed the reduction in stress due to acceleration, no matter how much the weight of the accelerated parts may be. The figure obtained for acceleration stress, which is 1,449 lb., is too low, for reasons hitherto explained, but, as it is to be deducted from the stresses on the rope, which are larger, the total of the stresses obtained by this calculation will be greater than it should be. As ultimately it will be shown that it is not the maximum total stress that the rope will have to withstand at other points in its

travel, the fact that the figure is too high will not change the factor of safety from which is derived the correct diameter and grade of the rope.

d. Decrease of stress due to rope friction on incline = $35 \times 2.03 \times 0.05 = 0.4 \text{ lb.(4)}$

e. Decrease of stress due to car friction = $48,600 \times 50 \div 2,000 = 1,215 \text{ lb.(5)}$

f. Stress due to weight of rope in borehole — $190 \times 2.03 = 386 \text{ lb. (6)}$

Once again, the direction of the several forces must be considered. Stresses (1), (2) and (6) help to accelerate the load, and stresses (3), (4) and (5) retard it. The algebraic sum $5,939 + 9 + 386 - 1,449 - 1,215 = 3,670 \text{ lb.} = 1.835 \text{ tons.}$

Deceleration at Bottom

D. Stresses When the Front Car of the Empty Trip Has Reached the Foot of Incline—The cars are being decelerated prior to landing, but the entire trip is on the incline.

a. Stress due to weight of empty cars on incline = $48,600 \times \sin 4 \text{ deg. } 4 \text{ min.} = 48,600 \times 0.0709 = 3,446 \text{ lb.(1)}$

b. Stress due to weight of rope on incline: $1,168 - (105 \times 2.03 \times 0.0709) = 1,153 \text{ lb.(2)}$

c. Stress due to deceleration, where deceleration takes 15 seconds: rope length = length of incline — length of trip + $190 + 149 = 7,578 \text{ ft.}$
 $F = Ma$

$$= \frac{48,600 + (7,578 \times 2.03)}{32.2} \times \frac{14}{15}$$

$$= 1,855 \text{ lb.(3)}$$

d. Decrease in stress due to rope friction on incline = $7,239 \times 2.03 \times 0.05 = 735 \text{ lb.(4)}$

e. Decrease in stress due to car friction = $1,215 \text{ lb.(5)}$

f. Stress due to weight of rope in borehole = 386 lb.(6)

Stresses which cause a pull on the rope are (1), (2), (3) and (6), and those that reduce the pull are (4) and (5). The algebraic sum of the stresses is $4,890 \text{ lb.} = 2.45 \text{ tons.}$

So far we have computed the maximum stress on the rope to be 9.46 tons, which occurs during the time that the loaded cars are being hauled without acceleration up the bottom of the incline. Now we must consider whether there are any points on the incline where the stresses on the rope, while the load is being hauled at constant velocity, are greater than the stresses during the acceleration period. The stresses due to loaded trip on incline and to car friction are constant, so the procedure is simple and by using the

following rule the point of maximum stress can readily be located and computed.

If the sine of any angle in the incline is greater than tension, due to weight of load at point of maximum acceleration, plus acceleration stresses divided by total weight of load, then the stresses on the rope usually will be greater at this point.

This might not be so where the sine is only slightly greater than in the inclination calculated because there is not so much rope on the incline when the trip is at the top of the slope as there is when it is further down, and a section near the foot of the incline that would give an approximation to that figure might exceed it when consideration is given to the weight of rope and its frictional resistance.

The sine of the section of the incline in this case must not be greater than $(1 + (3) \text{ of section } A = \text{total weight of loaded car trip } (9,841 + 3,348) \div 138,600 = 0.09516$. There are two inclinations on this slope which have larger sine values than 0.09516, one being 0.1083 and the other 0.1222. The maximum stress would occur on the steeper of these two gradients. Though the load travels 105 ft. on this gradient during the deceleration period, it must be hauled up $392 - 105 = 287$ ft. under maximum rope stress without the reduction of stress that occurs with deceleration.

Where Stress Is Greatest

E. Stresses When Loaded Cars Have Just Completely Entered the Top Section of the Incline—The section being 392 ft. long and the cars occupying the lower 105 ft. of it, the length of the rope on the incline will be $392 - 105 = 287$ ft., which, at 2.03 lb. per foot, will weigh 583 lb. On an incline having a sine = 0.1222, this will give stress due to weight of rope on the incline of $583 \times 0.1222 = 71$ lb. and stress due to rope friction $0.05 \times 583 = 29$ lb.

a. Stress due to loaded cars on incline as in B (1).....	16,037 lb.
b. Stress due to weight of rope on incline.....	71 lb.
c. Stress due to acceleration.....	0 lb.
d. Stress due to rope friction.....	29 lb.
e. Stress due to car friction as in B (5).....	3,465 lb.
f. Stress due to weight of rope in borehole.....	386 lb.
	20,888 lb.
	= 10.444 tons

This is the greatest total stress obtained, so on it must be based the diameter and grade of the rope. Using a factor of safety of 5, a rope that will carry 52.22 tons is needed.

Granted that a 1½-in. 6x21 improved plow-steel rope will carry 53 tons, the factor of safety using such a rope will be $53 \div 10.44 = 5.08$.

Engineers usually like to know what the factor of safety will be if more cars be added. Computations follow, therefore, for factors of safety with 20, 22 and 24 loaded cars at the location of maximum total stress, designated in E.

Stresses and safety factors for 20, 22 and 24 cars:

For 20 Cars

a. Stress due to weight of loaded cars on incline. = $7,700 \times 20 \times 0.1222$	18,819 lb.
b. Stress due to weight of rope on incline = $275 \times 2.03 \times 0.1222$	68 lb.
c. Stress due to acceleration or deceleration.....	0 lb.
d. Stress due to rope friction on incline = $275 \times 2.03 \times 0.05$	28 lb.
e. Stress due to car friction = $7,700 \times 20 \times 50 \div 2,000$..	3,850 lb.
f. Stress due to weight of rope in borehole.....	386 lb.
	23,151 lb.
	= 11.58 tons
Factor of safety = $53 \div 11.58$	= 4.58

For 22 Cars

a. Stress due to weight of loaded cars on incline = $7,700 \times 22 \times 0.1222$	20,701 lb.
b. Stress due to weight of rope on incline = $264 \times 2.03 \times 0.1222$	63 lb.
c. Stress due to acceleration or deceleration.....	0 lb.
d. Stress due to rope friction on incline = $264 \times 2.03 \times 0.05$	27 lb.
e. Stress due to car friction. = $7,700 \times 22 \times 50 \div 2,000$..	4,235 lb.
f. Stress due to weight of rope in borehole.....	386 lb.
	25,414 lb.
	= 12.71 tons
Factor of safety = $53 \div 12.71$	= 4.17

For 24 Cars

a. Stress due to weight of loaded cars on incline. $7,700 \times 24 \times 0.1222$	22,583 lb.
b. Stress due to weight of rope on incline. $252 \times 2.03 \times 0.1222$	63 lb.
c. Stress due to acceleration or deceleration.....	0 lb.
d. Stress due to rope friction on incline. $252 \times 2.03 \times 0.05$	26 lb.
e. Stress due to car friction. $7,700 \times 24 \times 50 \div 2,000$..	4,620 lb.
f. Stress due to weight of rope in borehole.....	386 lb.
	27,678 lb.
	= 13.84 tons
Factor of safety = $53 \div 13.84$	= 3.83

In selecting a wire rope for inclines, it is generally agreed that a factor of safety of 5 should be used where the rope is 3,000 ft. long or less; where the rope is longer than 3,000 ft., a factor of safety of 4 will suffice. Therefore, if the location of

maximum stress in this incline were toward the bottom of the incline, a distance greater than 3,000 ft. from the drum, it would be safe to load this rope with 22 cars. However, that is not so on this incline, because the point of maximum stress is near the top of the slope—only 626 ft. from the drum. Therefore, we must limit our load to 18 cars, which will operate with a factor of safety of 5.05, a figure in line with safe operation.

The following may be helpful in solving such a problem in the field. The percentage gradient is the tangent of the angle, thus a 10-per-cent gradient is the angle whose tangent is 0.10. The value of the angle the tangent of which is equal to a given gradient is obtained from the *C* scale of the ordinary polyphase slide rule. The sine of this is read from the *B* scale.

Where the angle is less than 6 deg.—the smallest angle on the slide rule—it is safe to consider that the sine is the same as the tangent. In other words, move the decimal point two places to the left when given the percentage grade, and that will give either the sine or the tangent to three decimal places. This is not true of larger angles because of the difference in length between the hypotenuse and the adjacent side of a right triangle. In angles below 6 deg., however, this difference is negligible.

Big Wires Resist Abrasion

So far, we have computed the stresses and from them the size and grade of rope. It now remains to select the proper construction of the rope. Slope-haulage ropes are subject always to severe abrasion. Therefore it is necessary to select a rope the outer wires of which are of maximum size yet are such as will adequately resist bending fatigue on the sheaves over which it operates. The sheaves in this case are of 72 in. diameter, or 64 times the diameter of a 1½-in. rope.

Inasmuch as the expected life of a rope of this character is rather long, the fatigue stresses must be reduced to a minimum by installing large sheaves. If a point is reached, however, where the user already has sheaves as large as headroom will permit, and these sheaves are not large enough for a 6x7 rope—one which has the maximum resistance to abrasion—then a construction must be selected that will offer sufficient resistance to the bending fatigue encountered and yet will have outer wires so large as to give, under the circumstances, sufficient resistance to abrasion.

OPERATING IDEAS

From *Production, Electrical and Mechanical Men*

Welded Cases Straightened By Use of Wheel Press

Motor cases distorted by arc welding are forced back to shape in a 200-ton wheel press in the central shops of the New River Co., Mount Hope, W. Va. It has been determined that maximum shortening of distance between diametrically opposite frame bolt holes amounts to $\frac{1}{4}$ in. on the field frames of the MH-110 motors of 13-ton locomotives. Before adopting the wheel-press practice about a year ago the frames were forced back to approximate shape by pulling the clamping bolts tight, but even then the frame pole pieces had to be machined to an unsatisfactory degree to restore them to a true circle.

The shortening of a surface by shrinkage after applying a fill or build-up by arc welding is now common knowledge. Many years ago this principle was utilized at times in this same shop to straighten bent locomotive axles. A bead or series of beads were arc welded along the high side to shrink that side and bring the axle back to straight. Turning off the bead to restore the finish to the axle had no appreciable

diminishing effect, thus indicating that the reason for shrinkage lay in the heating to fusion point and subsequent cooling rather than in the building up of the surface.

As is the usual practice at other shops, the frame halves are tightly bolted together and tacked by arc weld before the building up of the axle box and bearing head fits is begun. The differences in method as practiced in some other shops is that the welding is done more rapidly and without the expense of hand peening of each small section of weld after it is applied. Furthermore, the frames are not clamped onto mandrels during the welding nor during machining. The accompanying illustration shows an MH-110 frame set up on the table of a horizontal boring mill ready for remachining the filled axle bearing and housing fits.

When two halves of a frame are unbolted and cut apart after filling they spring to a distorted position, indicated by the fact that the fit surfaces are no longer parallel but instead gap at the inside. Procedure in the wheel press is to force the ram against the flat outside corner of the lower half of the frame with sufficient pressure

to bring its diametrically opposite clamping fit surfaces to conformation to a straight edge placed across the two. Then its clamping bolt-hole-centers distance is carefully measured and the second operation is to press the other half of the frame until its hole-centers distance is increased to equal that of the bottom half. Seventy-five tons was the maximum pressure required to straighten the halves of the field frame which is shown set up for machining.

Taking Machines Through Belt Done in Twenty-One Minutes

As cost is now the chief issue in mining, and as steady machine operation lowers cost, the supervisor's job in a mechanical mine is playing checkers with "Mr. Time," writes Ben Sweazy, Crooksville, Ohio, in describing a method of moving mining and loading equipment through a belt line without interrupting coal production. And the supervisor must take the first move and every move thereafter to win.

With only four men, it is possible to take a Joy 8BU loader, Jeffrey 35B cutter, two Jeffrey 61AM pan units and other tools through a belt line in 21 minutes in cases where it is impossible or too far to go around. In fact, this operation, when performed during a lunch period at the Jones all-mechanical mine, Zanesville, Ohio (*Coal Age*, May, 1937, p. 187), required just that time, reports Mr. Sweazy, who also acknowledges his indebtedness to E. M. Rife, whose views on the supervisor's task are expressed in the first paragraph, for cooperation in the development and application of the method.

Tools and equipment required in the operation consist of two Crescent wrenches, hammer, drift pin, eight pan bolts with nuts, two 1-in. boards 10 ft. long, lifting jack, two 3 x 5s just long enough to reach from the top of the belt pan to the roof, and two 1-in. boards 30 in. in length. All these materials should be in place at the point where the belt line is to be broken.

When the conveyor is stopped, two men lift the belt high enough to clear the Joy loader and then prop it with the 3 x 5s, which are topped by the 30-in.-long boards. If the belt is too heavy or too tight, the

By separate treatment each half of the frame has been pressed back to normal before rebolting for machining

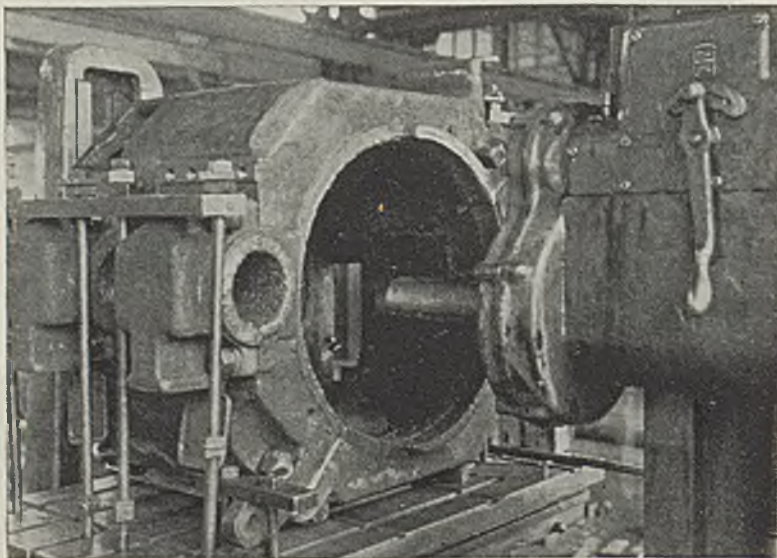

At Cincinnati, be sure to

VISIT BOOTH 806

Hazard Wires and Cables for the Mining Industry will include, among others, Bore Hole Cable, Armortite Power Cable, Mining Machine Cable and

HAZARD SHOT FIRING CORD (Type D)



with a distinctive orange braid, a bright color that makes this cord particularly distinguishable when lying on the floor or ground. Being so easily seen, it escapes much unintentional rough usage. But it also protects itself by having an insulation with a tensile strength of more than a ton per square inch. The tough, free-stripping rubber insulation adequately insulates the conductors even when lying in water. This cord is supplied in 100 foot lengths for your convenience.

HAZARD INSULATED WIRE WORKS

DIVISION OF
WILKES-BARRE



THE OKONITE CO
PENNSYLVANIA

lifting jack is used. With the belt raised at both ends of the pan to be removed, the nuts on the pan bolts are removed and the bolts are tapped out with the hammer and drift pin. The pan then is removed to one side to clear the road.

The two 10-ft.-long boards then are placed across the belt on the same gage as the caterpillar treads on the loader, which is taken through. The loader is followed by the cutting machine with one pan unit on the cutter bar and the other dragged by the cutter by means of a piece of old crab rope attached to the bar. The blower fan, drill and all tools can be loaded in the pan units, along with the tailstocks for the pan line. As soon as the equipment is past the belt line, the pan is replaced and coupled up with the eight pan bolts. Then the belt is dropped to complete the job.

Bulletin Boards Promote Safety At Alabama Fuel & Iron

Bulletin boards such as the one illustrated are a material help in the safety work carried on by the Alabama Fuel & Iron Co., Birmingham, at its various operations. When an injury occurs, a red light is placed beside the name of the foreman as well as beside the name of the man in his force directly responsible. A white light is carried beside the names of foremen who have had no injuries in their mines or departments over a six-months' period.

Under the Alabama Fuel & Iron system, a reward of one day's pay is given each worker in a mine which operates 180 days without a lost-time injury. The number of injuries has dropped materially since the reward and bulletin-board system was installed. Children in the schools are required to answer one question on safety daily and, as they usually have to consult their fathers for the correct answers, creation of a safety consciousness is facilitated. Women also study in classes sponsored by the U. S. Bureau of Mines.

Attractive bulletin boards help make safety-minded men.



On to Cincy!

May 2 marks the beginning of the annual American Mining Congress convention and exhibit of coal-mining equipment at the Music Hall in Cincinnati, Ohio. No operating, electrical, mechanical or safety man should miss it, as there are few occasions when as many ideas for efficient mine operation are available in one place. But when you get back to the mine, the Operating Ideas department of Coal Age still will be on the job sifting the experience of men throughout the country for your benefit. Perhaps you, yourself, have worked out something that has saved you time, trouble or money or has made your mine a safer place to work. If you have, here is the place to pass it on so that others may profit by your experience. So send in this idea, along with a sketch or photograph if it will help to make it clearer. If acceptable, it will bring you \$5 or more from Coal Age, as well as our sincere appreciation.

Pumping Cost Cut 60 Per Cent By Drilling Borehole

Drilling a borehole a number of years ago at the No. 6 mine of the Central Elkhorn Coal Co., Estill, Ky., cut pumping cost nearly 60 per cent, reports E. A. Smith, chief engineer. The problem was either to put down a borehole from the surface at a point 900 ft. from the pump or force the water to a drift 2,200 ft. away. Production was to be 250 g.p.m., and 3-in. lines were to be considered in the preliminary calculations in both cases, with the borehole to be fitted with such a large casing as to give very little friction with the small volume of flow.

Friction head on the 3-in. line at 250 g.p.m. was estimated at 7.76 lb. per 100 ft. of length, or a total of 69.84 lb. per square inch for the distance from the pump to

the borehole. Adding 51.11 lb. for the vertical column of 118 ft., a total pressure of 110.95 lb. against the pump was estimated. Using the same figure per 100 ft. of line, it was estimated that friction in pumping 2,200 ft. to the drift was 170.72 lb. Adding 6 lb. for a rise of 14 ft. gave a total of 176.72 lb. per square inch. By subtraction, the difference in favor of the borehole is seen to be 65.77 lb. Thus, it would have cost nearly 60 per cent more to pump the same volume to the drift, as compared with up the borehole. The estimated saving in power alone was \$5.40 per day, or \$1,994 per year. Consequently, the borehole was drilled and it is estimated that it paid back its cost several times in the first year.

Cable Splice Improved With Brass Tubing

"There are times when it is not possible to find the right man at the right time to splice a wire rope, as it is a task that requires a background of experience if a good, serviceable job is to result," points out Charles H. Willey, Penacook, N. H. "But if the cable is one which does not have to run over a sheave or through a block, all that is necessary is a mechanical means of joining the two ends. There are many ways of doing this, in addition to clamps ready made for the task, but in the accompanying sketches I call at-

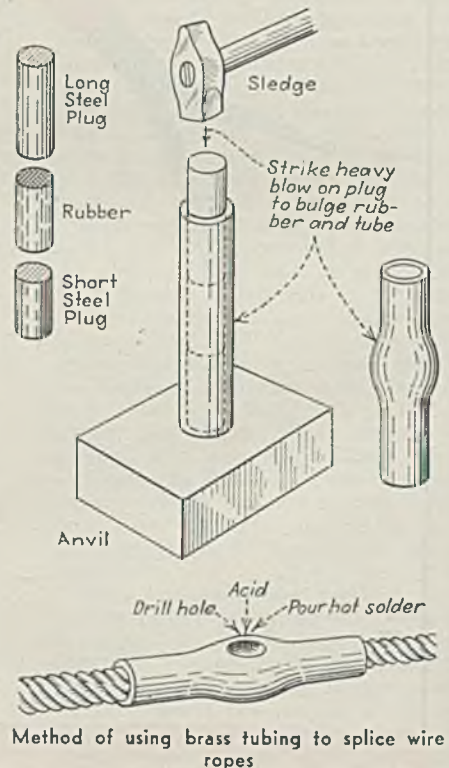

Method of using brass tubing to splice wire ropes

attention to a different method of making a strong, useful and neat splice.

"As the first step, select a short piece of brass tubing that will fit the rope. Then make a rubber plug about 1 in. in length and two steel plugs—one long and

STANDARD OIL COMPANY'S *New* STANOIL

Solves gumming troubles on a compressor

STANOIL, one of the greatest recent developments in industrial lubricants, has already demonstrated its trouble-saving, cost-reducing qualities on hundreds of applications.

At one refrigerator manufacturing plant gummy deposits were sticking the unloader on a compressor. After numerous other lubricants had failed to give relief, Stanoil No. 25 completely eliminated the trouble.

Again, Stanoil No. 18 on an elevating conveyor improved operation in cold weather and materially reduced power consumption.

Crank bearings on a small steam engine in the power plant of a milling company were being replaced every two weeks. Stanoil No. 25 was placed in this engine over a year ago and no bearings have needed replacing since then.

Made in seven grades for a wide range of applications, Stan oils make good lubrication possible on the most difficult jobs and provide low-cost lubrication wherever highly refined and highly stable oils are needed.

Ask a Standard Lubrication Engineer to point out operations in your plant which could be better lubricated, at less cost, with Stan oils. Call him at your local Standard Oil (Indiana) office or write 910 So. Michigan Avenue, Chicago, Ill.

Copyr. 1938, Standard Oil Co.

STANDARD OIL COMPANY (INDIANA)

THE RIGHT
LUBRICANT
•
PROPERLY
APPLIED

our electrical plant than in the other direction. Then with a chain of the bridge after the legs were down against the timber and the lower short pier. The result will be a bridge in the center of the shaft. A large wire or a pipe can be used in place of the bridge if available.

able. Drill a hole in the bridge, insert the ends of the rope and jam them together so that the wires will interlock and spread out into the bridge. Put some weight on the line, drill with water wash and clean. You then have a joint as strong as the cable.

time but avoided where it became weighing up to 2,000 lb. have to be handled over a maze of power circuits—often while the mine was in operation. Even single-track openings, where 12-ft. crossbars had to be placed where the tape displaced a span of only 4 ft., offered problems of other than weight or fit.

I-Beams With Legs Not Less Than 10 In. Used in Timbering Permanent Haulway

ROOF SUPPORT is an ever-present problem in our industry when it is a problem at all, comments H. H. Bennett, Springfield, Ill., in reporting on a timbering job at a mine in that vicinity. "So we set out all the working dimensions over some months ago, because they are not included in any present decision. Just the Mine Superintendent McFarish gives the problem and the material and told what the work must be done."

"I have been my experience that a good set mine in this field seldom finds its greatest roof difficulties at or near the working face unless extra space has to be provided for a passing track or parting, and such usually are not so near the working face. I have to admit a coal mine that has been in operation more than half a century, where a forest of trees that had made, set side by side, were killed in all manner of every angle and were distributed where they had promised to do the most good, where one had double of one covered the roadway at all—all this offering some evidence of nature's impatience over the rate of the prevalence of the Carboniferous Era. Excavations were common four or five times a year and only when absolutely necessary were the broken timbers removed. The procedure, sanctified by long practice, might have continued for all time were it not for the common necessity for all enterprises to trim their sails to the changing winds and set costs."

"The place in this regard for greater economy made imperative a greater care on all haulage roads. The removal of miles of side-by-side roadway timbers from under a top that offered every known hazard called for the exercise of infinite resource and more than ordinary skill. Two to three feet of timber and slate or rock had to be taken down and I-beams were to replace wood across the roadway, resting on rounded, peeled white oak legs not less than 10 in. in diameter at the small end—more often twice that size—with a life estimate of fifteen years."

"The stratum immediately above the coal was a troubled slate ranging from a few inches to 4 ft. in thickness. Giant 'nigger-heads' 3 to 4 ft. in diameter dotted the top and sides, with korschucks of a flinty gravel consistency 2 to 3 in. to 25 many feet thick cutting the seam out entirely at intervals averaging 50 ft. throughout the mine. The drying effect of the mine air through the years had resulted in almost complete disintegration of the overlying stratum, including, to a lesser degree, the limestone. Above both is a soap-

stone of goodly thickness, such that rooms 24 ft. wide have caved more than 25 ft. high.

"Obviously, it was unfeasible to take chances with the usual type of pine timbers available other than the projected roof supports represented quality costs and the area specifications were so rigid. The standard was adopted was: 6 ft. from top of rail to underside of crossbar and 36 in. from the outside of the rail to the face of the leg—no more, no less. Six single round-ways, 10 in. by 12 ft. long, in double-track openings, 12- to 15-in. multiple-length I-beams 18 ft. long.

"A system of installation had to be worked out that would have the twin merits of being clear to the average intelligence and yet result in a workmanlike job. Sturdy work to poor economy any

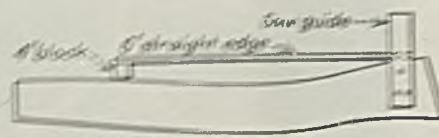

Fig. 1—Sawing method of securing uniform cuts for pitch of legs

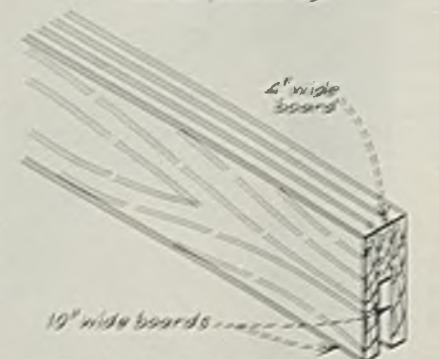

Fig. 2—Details of trolley-wire cleave

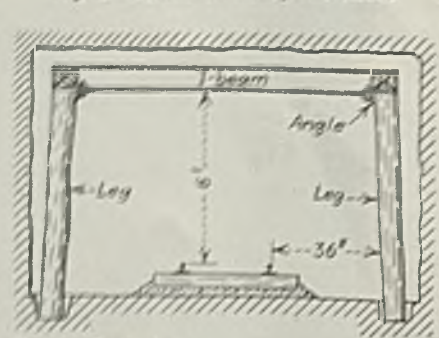

Fig. 3—Typical I-beam set, showing placement of angles to counteract side pressure

"In preparing for a good job, strict instructions should be given that only the best part of the timber be used, as there is a tendency to take the easy way. This necessitates cutting all timber twice—once for pitch, as near as possible to the butt end, and again for the exact length. It was required that sub bottom be reached before the length measurement was taken. The track was leveled up and where the rails were not exactly level the high rail was taken as the base from which a level straight-edge was extended out over the leg hole and the depth from the bottom of the straight-edge was measured with a rule. Adding the required 6 ft. to this measurement, plus 1/2 in. for settlement, gave the required length.

"A leg-hole depth up to 20 in. under the rail-head level requires 5-ft. legs to provide a margin for squaring and accommodating the pitch. In some cases, where the heave had been considerable, we had to sink over 2 ft. under the track to find suitable bottom. In no case should the base of the leg be higher than the base of the rails, unless a hitch in the solid rib coal has to be cut.

"One of the most useful tools possible on a job of this kind is a churn-drill bar with a pick on one end and a chisel point on the other.

"When the legs have been placed where they belong they should be cleated with 30d nails to the adjacent timbers after plumbing, with the cleats a trifle higher than the trolley. Wire and cleats are a definite help as a means of temporarily resting the I-beam while it is being placed in position. As most of the work was done while the mine was in operation, the hot-wire danger was eliminated by using a trolley-wire sleeve made out of three pieces of pine board about 4 ft. long, as indicated in Fig. 2. A 4-in.-wide board between and at one edge of two 10-in.-wide boards makes the sleeve, which fits snugly over the trolley wire to eliminate the possibility of shock. Even all-safety shoes require an additional safeguard.

"Each beam should be, and was, side-

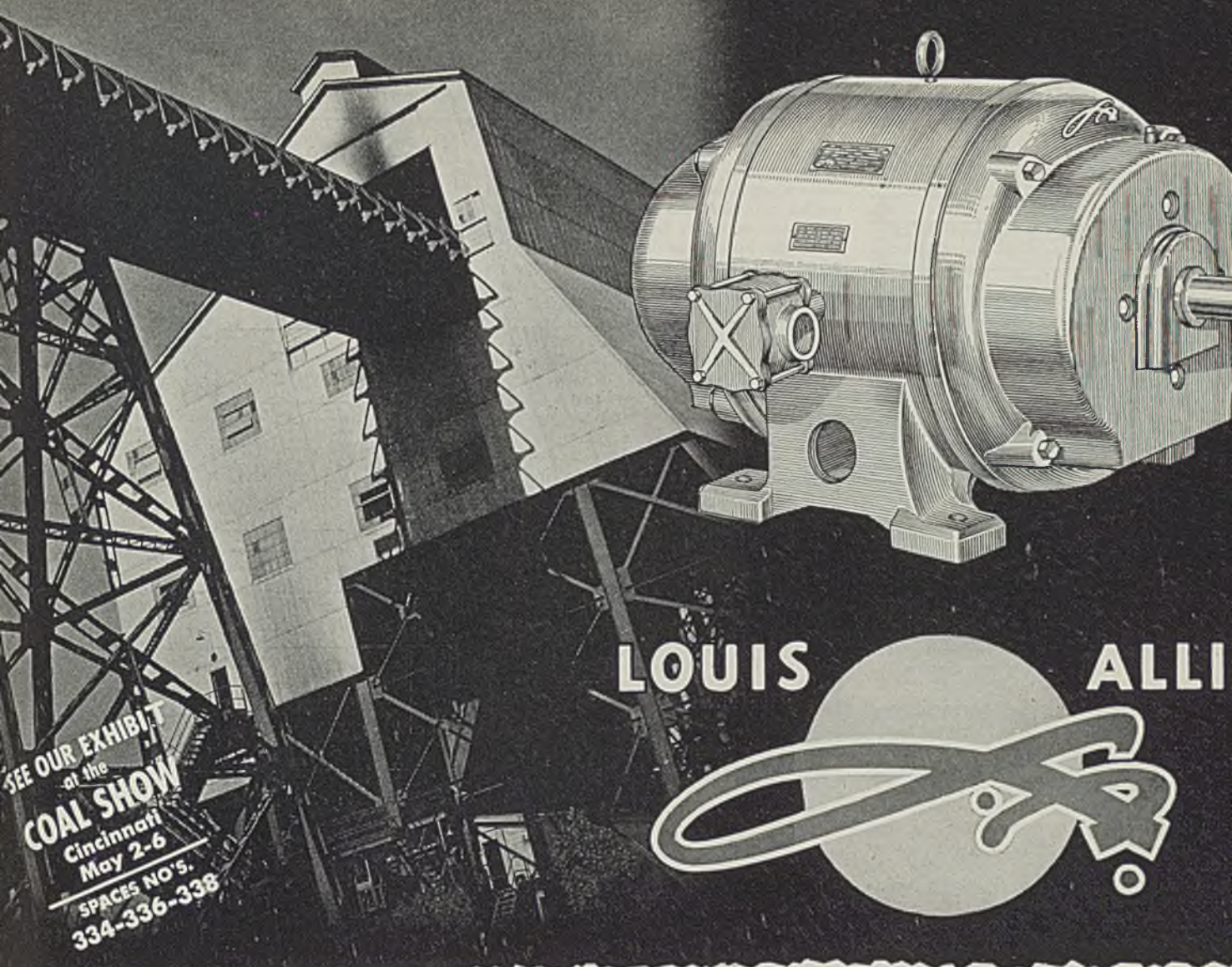

SEE OUR EXHIBIT
at the
COAL SHOW
Cincinnati
May 2-6
SPACES NO'S.
334-336-338

LOUIS ALLI



Built For Coal Production

The Louis Allis **SPLASH-PROOF** motor has been designed and built from the ground up in every detail to deliver absolutely dependable performance on your very toughest coal mine jobs.

Protected from every angle against the most severe operating conditions by its smooth heavy solid cast-iron housing—special bearing chamber guard—scientifically designed water baffles and traps in the air passages—and a protective composition coating on the windings—THIS motor unquestionably assures the coal mine operator of uninterrupted motor operation under most severe conditions. These motors are available in both D.C. and A.C.—a SIZE and TYPE for every job—from the coal face to the tippie.

Write for copy of our 60 page illustrated catalog No. 700 which fully describes our complete line of motors for coal mine operation—also contains valuable engineering and maintenance data, on practically every type motor.

SPECIAL D. C. MINE MOTOR

This direct current motor has been especially designed for general all-around mine use. The drip-proof end bracket and covered commutator permits proper ventilation and also protects against dripping water or falling particles. Ask for complete details of special mine motor (Type GNA) and they will be sent promptly.

EXPLOSION-PROOF

For gaseous mines, write for complete information on our A.C. and D.C. explosion-proof motors, that are available in a wide range of electrical characteristics to meet every mine operating condition.

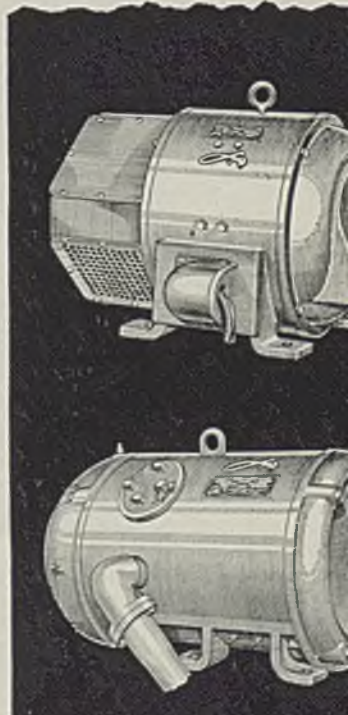

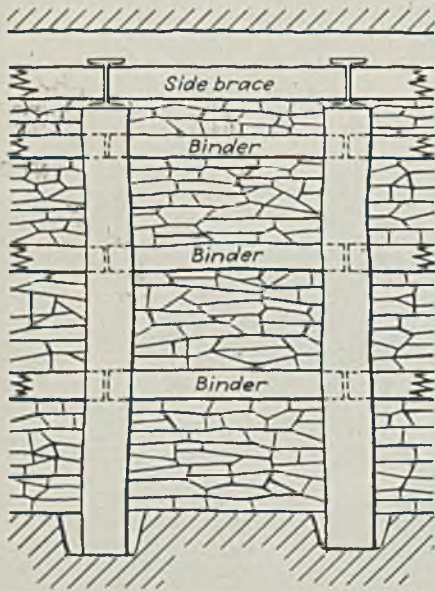

Fig. 4—Typical example of walling between legs and installing auxiliary binders

braced at the ends as soon as the installation was completed. Any kind of solid timber as wide as the web of the I-beam is effective. The bark first should be removed and then the ends of the braces should be cut on a slight pitch so that they can be driven tightly into place.

"In parts of the mine the roof was so badly disintegrated that a place the size of one's head yielded a seemingly interminable flow which would fill the entire heading before it could be checked. In such places, the I-beams were set on 3-ft. centers. Seven-foot white-oak props were cut exactly in two and were flattened on two sides to make what were locally termed runners. As the old timbers or debris were removed, starting on one side of the place, for example, these runners were extended forward from the last I-beam to the place where the next was to be installed, with the inner ends of the runners resting on temporary jack props. Allowing space for installing the next series of runners ahead, oak boards just long enough to reach crosswise from the center of one runner to the next then were laid on top of the runners like a floor as soon as enough space was made to place them. This process was continued across the heading until it was readied for another I-beam.

"Side pressure was counteracted by bolting a short angle to the beam immediately in front of the top of the leg, as shown in Fig. 3. This work was done by the electrical department after the set was in place. Loose side was checked by walling between the legs and binding the walls with split props at 2-ft. intervals, as indicated in Fig. 4.

"In some places, a new wrinkle was adopted instead of placing the large quantity of timbering usually employed in cribbing up to the top of high caves. As an example, in driving through some old workings to develop a new territory, a cave about 300 ft. long, nearly 30 ft. high and bellying out 18 ft. wide over the coal line in a heading that had been

driven 12 ft. wide about ten years ago, was encountered. I-beams were set on 5-ft. centers and the space between legs was walled up with binders to the tops of the beams on either side. A solid floor of 6-ft.-long props was laid on top of the I-beams, with a second layer of props on top to break the seams. Platforms then were erected and much of the fall and dirt resulting from subsequent grading was packed over the beams. It wasn't practicable to fill the entire area over the beams with this dirt, but a surprisingly large space was packed and served a triple purpose: saved cribbing and lagging timber, furnished a stowage space for dirt which otherwise would have had to be hoisted, and provided a cushion for any future falls.

"One to two days, as a rule, was required to complete an ordinary I-beam set, depending upon the difficulties encountered, with a cost of about \$12 to \$15 per set for labor alone. This cost might seem high, but when spread over fifteen years, with accompanying freedom from haulage interruptions and almost certain safety at all times, there is ample reason to believe that the results amply justify the investment."



Springs Prevent Transmission Of Sharp Vibrations

To protect from vibration the vacuum tubes of five Syntron controllers which supply the same number of Traylor vibrating screens in the mechanical cleaning and screening plant at Zeigler No. 2 mine, Bell & Zoller Coal & Mining Co., Zeigler, Ill., these controllers are hung on coil springs. This arrangement, with flexible wiring-connection loops at the bottom, is shown in the accompanying illustration. The method has proved effective in eliminating vibration damage to the tubes, which supply the current to the electromagnets and give a screen vibration equivalent to direct operation on 30-cycle power.

Springs prevent transmission of sharp vibrations.

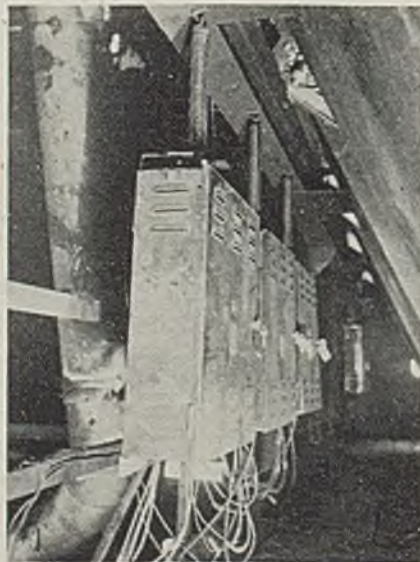

Guard Rails Fastened By Special Clamp

As keeping guard rails on switches where motors are operated on 25-lb. rails proved a difficult matter with the ordinary method of fastening the guard rails in place, due to the flanges on the locomotive

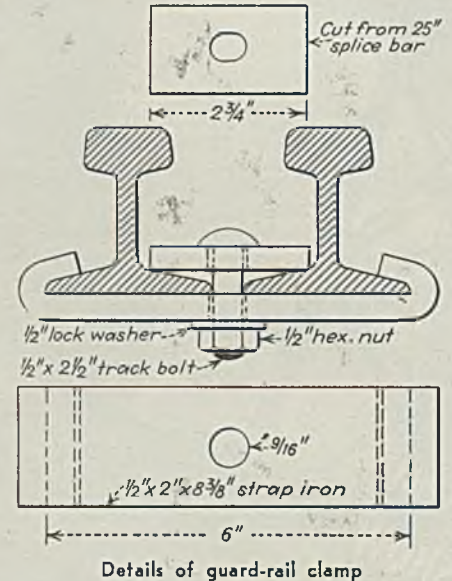

wheels shearing off the bolts, A. M. Kalasky, foreman, Warwick No. 1 mine, Harwick Coal & Coke Co., Greensboro, Pa., devised the guard-rail clamp shown in the accompanying illustration. Two such clamps are used on each guard rail.



Replacement Facilitated By Split Bushings

To facilitate changing two of the bushings on the intermediate shaft of a Goodman 12AA cutting machine and eliminate the looseness and noisiness of the gears

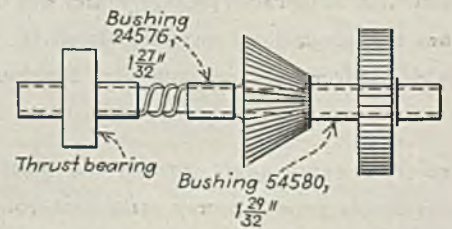

Diagrammatic sketch showing points where split bushings were installed

and pinion formerly encountered as a result of removing them to install new bushings, John Gross, Ohio Block Coal Co., New Philadelphia, Ohio, hit upon the idea of using split bushings. These split bushings were made to replace Bushings Nos. 54,576 and 54,580. The latter had to be shortened to 1 29/32 in. on account of the shape of the bevel pinion. As a result of the adoption of the new type of bushing, both can be changed in no time without removing any gear or pinion, Mr. Gross states.

WHAT'S NEW

In Coal-Mining Equipment

SAFETY AIDS

A new model of the McDonald safety hat (Type T) said to combine maximum strength with cool light-weight comfort features is announced by the Mine Safety Appliances Co. The hat includes a duralumin shell for protection against flying or



falling objects. The shell is corrugated to provide maximum resistance to blows, and is fitted with a leather headband which, with the cradle straps, is said to be easily and quickly adjusted or changed.

Complete respiratory protection in any atmosphere for at least one hour under the most severe working conditions is stated to be afforded by the new M-S-A light-weight one-hour oxygen-breathing apparatus, bearing U. S. Bureau of Mines Approval No. 1306.



Weighing only 18 lb., the apparatus is described as compact, comfortable to carry and fully automatic in supplying the required quantity of oxygen.

M-S-A also offers the newly developed "Dustfoe" respirator (Approval No. 2115) weighing less than 3½ oz. and stated to provide full protection with a maximum of comfort under the



most severe working conditions. Features are: full vision in any direction; no interference with goggles, spectacles, welding helmets or head coverings of any kind; quickly replaced metal parts of aluminum; adaptability of all parts, including the easy-fitting soft-rubber face cushion, to sterilization at any time; low-cost, quickly replaceable cellulose filters; and ability to eliminate dust particles as small as one micron with maximum efficiency and low breathing resistance.

CRUSHER

A new two-roll spring-relief coal crusher (Type C, chain drive) has been placed on the market by the Link-Belt Co., Chicago. Standard sizes include rolls 26, 30 and 36 in. in diameter. The high capacity with limited degradation inherent in two-roll crushers and the ease of adjustability for regulating the size of the product always claimed for single-roll crushers are said to be combined in one strong, well-constructed, compact unit. "Silverlink" roller chain is used as driving connection to both rolls, which are of the segmental type (cast-iron spiders to which are bolted heavy heat-treated alloy-iron segments removed readily without taking off the side housing). An all-welded steel frame is provided,

combining lightness with strength, and the unit also is said to incorporate smooth and quiet operation with low maintenance.

Tests and service results, it is stated, show that more accurate sizing than with the usual two-roll crusher is possible. Also, smaller flywheels and higher-speed motors can be employed. As much as 39 in. in



headroom has been saved in the case of the 36-in. unit, and in comparison with an older 36-in. unit with 48-in.-long rolls, the saving in length was 76 in. and in width was 20 in.

POWER PUMPS

Fairbanks, Morse & Co., Chicago, has introduced a new line of duplex power pumps with eight-cover side-pot-type fluid ends and inclosed self-oiling power ends fitted with herringbone gears and large roller bearings. Capacities range up

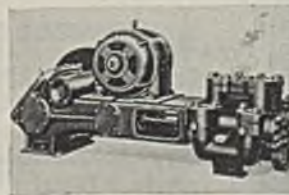

to 187 g.p.m. and pressures up to 1,000 lb. per square inch. The units are available as basic pumps, with pulleys for belt drives or as complete, compact motor-driven pumps covered by a single manufacturer's guarantee. The pumps bear the designation Figs. 6184 and 6185 and the same fluid end also is available on the Fig. 6285 duplex steam pumps of the company.

CENTRIFUGAL PUMPS

A complete new line of single-stage side-suction ball-bearing centrifugal pumps is announced by Goulds Pumps, Inc., Seneca Falls, N. Y. Eighteen sizes with capacities of 5 to 1,800 g.p.m. against heads up to 110 ft. are available for flat- or V-belt or direct-



motor drive. Construction features cited by the company include: latest hydraulic design of casings, impellers and stuffing boxes; structural strength and amply proportioned parts without excess weight; high-quality materials, ingenious design and fine workmanship for outstanding trouble-free performance and long life; and low cost.

DRILL RIG

Sullivan Machinery Co., Claremont, N. H., offers the new Class UW-161 "Featherweight" drill rig using the Sullivan L-12 hand-held drill as the drilling medium, with the L-12 in turn operated by the new Sullivan J-5 automatic chain feed. With the automatic feed, according to the company, maximum drilling speed and efficiency can be obtained day after day. Less time is spent in changing steels or pulling stuck steels, resulting in more actual drilling and lower costs. Specific features pointed out by the company include: double the daily footage of a hand-held drill; less air consumption than the two drills which can be replaced; smaller gasoline consumption; handling by one man; and lower labor cost, as one man can do the work of two.



WHEN TO USE *PRE-FORMED* ROPE



HOIST LINES ON EXCAVATORS



HOIST LINES ON SHOVELS



SCRAPER LOADER LINES



CONVEYOR ROPES



HAULAGE LINES



CAR PULLERS

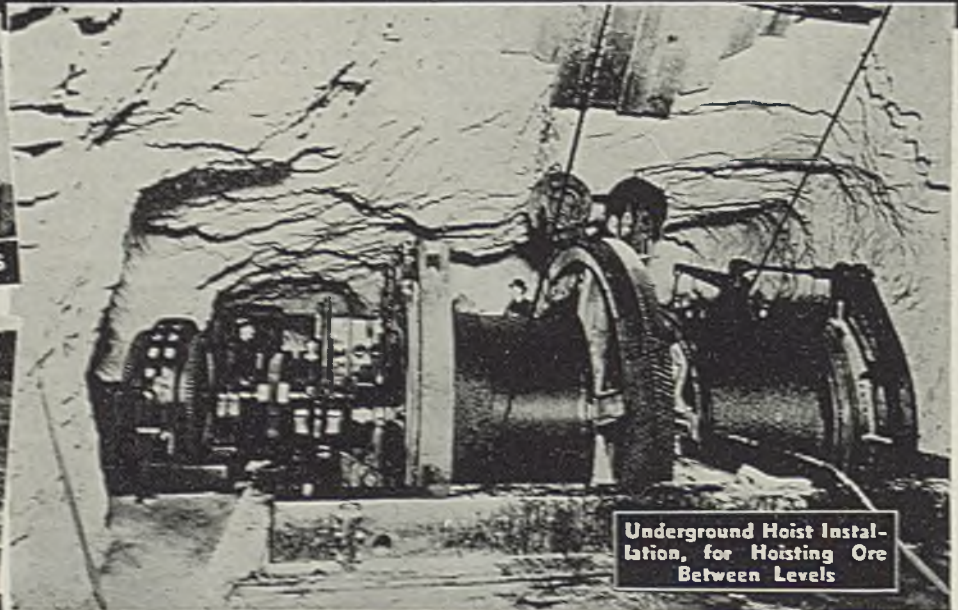

Underground Hoist Installation, for Hoisting Ore Between Levels

-in MINING -for actual ECONOMY

● Pre-formed ropes cost more. Thus they are admittedly **EXPENSIVE** for services where their special advantages are not needed. In services, however, where these advantages **ARE** needed, their use represents a **PRONOUNCED ECONOMY**. In mining, we recommend **UNION**-formed (our pre-formed) Rope, as a proven money-saver, in these services:

1. **SHAFT-HOIST ROPES:** As these must withstand extraordinary bending stresses.
2. **HOIST LINES** on Stripping, Digging and Loading Machines: As these must withstand extra-severe bending.
3. **MINING MACHINE LINES:** As these must withstand bending and abrasion. Broken wires will not stick out, jaggging men. Broken strands will not whip out, causing injuries.
4. **SCRAPER LOADER LINES:** For same reasons as Mining Machine Lines.
5. **CONVEYOR ROPES:** As subjected to heavy abrasion.
6. **HAULING LINES, SLUSHER AND MUCKER LINES, CAR PULLERS, HOIST LINES** on derricks, cranes and other construction machines.

The recommendations of our engineers are made without obligation and will almost certainly reduce your rope expense. Write fully.

UNION WIRE ROPE CORPORATION
 Offices and Factory: 21st and Manchester, Kansas City, Mo.
 Chicago Office and Warehouse: 431 W. Peckling Road, Yards: 1658
 Portland, Ore: 2415 N. W. 22nd Ave.
 Mexico: E. O. Chapo, Calle Dumas Sur 12, Tampico.
 Export: Lacey Export Corp., Woolworth Bldg., N. Y.—London.
 Distributors in Leading Cities Throughout the Country.



UNION

UNION WIRE ROPES

◆ The "ULTIMATE LOW COST WIRE ROPE" ◆

WORD FROM THE FIELD

State Control Recommended For Anthracite

State control of the anthracite industry was recommended by Governor Earle's commission in its final report, presented on April 6 after more than a year's study. The commission, headed by W. Jett Lauck, economist, and including Morris L. Ernst, New York attorney; Joseph Agor, Shamokin (Pa.) newspaperman, and James W. Angell, of Columbia University, proposed that a permanent body similar to the Public Utilities Commission be established to regulate the industry by fixing prices.

That a marketing corporation be set up which would eventually eliminate present wholesalers and retailers also was suggested. This corporation would not only handle the sale of hard coal but would promote its use through advertising and the further introduction of automatic coal-burning equipment.

It was proposed to end "bootleg" mining by setting up three other corporations to handle idle coal lands, engaging unemployed and free-lance miners. Land would be leased from private companies with a 4,000,000-ton annual limit placed on output. Issuance of deferred interest bonds to give the State eventual ownership of the coal lands was advised.

Major W. W. Inglis, president, Glen Alden Coal Co., characterized the report as "too communistic" and said the recommendations were impractical. Similar views were expressed by Harry J. Connolly, vice-president, Pittston Co.

New Preparation Facilities

E. O. GUTHRIE, Guthrie mine, Blanche, Ky.: contract closed with Morrow Mfg. Co. for five-track tippie, including shaking and vibrating screens, loading booms, crusher and conveyors; capacity, 200 tons per hour; to be completed about Aug. 1.

HARDY-BURLINGHAM MINING Co., Hardburly, Ky.: contract closed with Morrow Mfg. Co. for four-track tippie, including shaking screens, shaking picking tables, loading booms and conveyors; capacity, 500 tons per hour; to be completed about July 1.

Seek W.P.A. Work for Miners

A resolution requesting Works Progress Administration employment for part-time employees of the Illinois coal-mining industry was submitted by the Illinois Reciprocal Trade Association on March 24 to the Administrator of W.P.A., the Governor of Illinois and the executive secretary of the Illinois Emergency Relief Commission. The resolution asked that the regulations governing certification for



employment on W.P.A. projects be immediately and uniformly amended "so that workers at present subsisting on part-time employment in the coal industry may be transferred or certified to W.P.A. employment without delay, and may receive part-time or full-time employment on such projects to the extent that the sum of their monthly earnings from both sources of employment shall at least equal the security wage established by W.P.A. for the areas in which they reside."

Coming Meetings

- American Mining Congress: 15th annual coal mining convention and exposition, May 2-6, Music Hall, Cincinnati, Ohio.
- American Wholesale Coal Association: annual convention, May 18-21, Cavalier Hotel, Virginia Beach, Va.
- Mine Inspectors' Institute of America: 29th annual convention, St. Nicholas Hotel, Springfield, Ill., June 6, 7 and 8.
- American Retail Coal Association: annual convention and coal exposition, June 6-12, Hotel Sherman, Chicago.
- Big Sandy-Elkhorn Coal Operators' Association: annual meeting, June 7, Ashland, Ky.
- Illinois Mining Institute: twentieth annual boat trip and summer meeting, June 10-12, aboard Str. "Golden Eagle," leaving St. Louis June 10 and returning June 12.
- Mining Society of Nova Scotia: annual meeting, June 21 and 22, Sydney, N. S., Canada.
- Rocky Mountain Coal Mining Institute: 36th annual meeting, June 23-25, Shirley-Savoy Hotel, Denver, Colo.
- American Society for Testing Materials: annual meeting, June 27 to July 1, Atlantic City, N. J.
- Greenbrier Smokeless Coal Operators' Association: annual meeting, July 12, Pioneer Hotel, Rainelle, W. Va.
- Pocahontas Electrical and Mechanical Institute: annual meeting, Aug. 18-20, Bluefield, W. Va.

Cincinnati Equipment Show Taxes Facilities

Exposition features of the Fifteenth Annual Coal Convention and Exposition to be held under the auspices of the Coal Division of the American Mining Congress at Music Hall, Cincinnati, Ohio, May 2-6, will tax the exhibiting facilities, as more than 145 exhibitors have contracted for all of the available space. The list of exhibitors as of April 7 included:

- Acme Compressor Co.
- Advertising Displays, Inc.
- Aerovent Fan Co.
- Air Reduction Sales Co.
- Louis Allis Co.
- Allis-Chalmers Mfg. Co.
- American Brattice Cloth Corporation
- American Bridge Co.
- American Car & Foundry Co.
- American Chain & Cable Co.
- American Cyanamid & Chemical Corporation, Inc.
- American Mine Door Co.
- American Steel & Wire Co.
- Anaconda Wire & Cable Co.
- Atlas Powder Co.
- Baker Raulang Co.
- Barber-Greene Co.
- Bemis Bros. Bag Co.
- Bethlehem Steel Co., Inc.
- Black's Directory
- Bowditch Co.
- Broderick & Bascom Rope Co.
- Brown-Fayro Co.
- Bucyrus-Erie Co.
- Calcium Chloride Association
- Carnegie-Illinois Steel Corporation
- Central Electric Repair Co.
- Chicago Pneumatic Tool Co.
- Cincinnati Mine Machinery Co.
- Coal Mine Equipment Sales Co.
- Coal Process Co.
- Coal Times
- Coffing Hoist Co.
- Columbia Steel Co.
- Cook, A. D., Inc.
- Cyclone Fence Co.
- Deister Concentrator Co.
- Deister Machine Co.
- Deming Co.
- Differential Steel Car Co.
- Dorr Co., Inc.
- Duff-Norton Mfg. Co.
- E. I. duPont de Nemours & Co., Inc.
- Dustlax Systems, Inc.
- Edison, Thos. A., Inc.
- Electric Railway Equipment Co.
- Electric Railway Improvement Co.
- Electric Storage Battery Co.
- Enterprise Wheel & Car Corporation
- Fairbanks, Morse & Co.
- Flood City Brass & Electric Co.
- General Electric Co.
- Gibraltar Equipment & Mfg. Co.
- Goodman Manufacturing Co.
- Gulf Oil Corporation
- Halliburton Oil Well Cementing Co.
- Harnischfeger Corporation
- Hazard Insulated Wire Works, Division of The Okonite Co.
- Hendrick Mfg. Co.
- Hercules Powder Co.
- Hockensmith Wheel & Mine Car Co.
- Hufburt Oil & Grease Co.
- Imperial Bronze Mfg. Co.
- Irwin Foundry & Mine Car Co.
- I-T-E Circuit Breaker Co.
- Jeffrey Manufacturing Co.
- Joy Manufacturing Co.
- Joyce-Cridland Co.
- Koppers Co.
- LaBour Co., Inc.
- La-Del Conveyor & Mfg. Co.
- Leschen, A. & Sons Rope Co.
- Link-Belt Co.
- Lincoln Engineering Co.

National Coal Association Starts Campaign To Recover Tonnage Lost to Oil

CITING tremendous losses by bituminous coal to fuel oil and hydro-electric power in New England industries, the National Coal Association asserts that when manufacturers replace coal with fuel oil or other substitute they are pursuing a course calculated to impair the market for their own products, as they are directly diminishing consumer purchasing power. In press releases on March 30 and April 4, N.C.A. pointed out that in a recent hearing before the Interstate Commerce Commission involving coal rates to Virginia tidewater it was revealed that 1,117 manufacturing and industrial plants in New England, representing an annual consumption of 6,262,820 tons of coal, had switched from bituminous coal to fuel oil or hydro-electric power. These figures, while covering actual instances, are conceded to be far from complete.

While disclaiming any attempt to dictate to any consumer what kind of fuel or energy he should use in his plant, the association stresses the fact that this loss to the coal industry—as well as to the railroads—contributes directly to unemployment, since every ton of coal displaced by fuel oil, natural gas or hydro-electric power results in the permanent displacement of one day's work and wages for one man in the mines, railroads and other agencies concerned with the production, transportation, distribution and delivery of coal. If men don't work, it is emphasized, they don't earn, and if they don't earn they cannot buy.

Out of every dollar received by coal operators for their product, says the association, 60 to 70c. goes to the miners in wages; out of every dollar received by the railroads for transporting coal, about 43c. goes to rail employees in wages. Incidentally, it is pointed out that the soft-coal industry was the first major industry in the country to put into effect the 7-hour day and 35-hour week, wages having been raised about 100 per

cent above the 1932 level; but with working opportunities decreasing there is little effect on purchasing power.

On the other hand, with the production of fuel oil and the generation of electricity involving comparatively little labor, it is argued, there is little likelihood that much of the money spent by a manufacturer for oil or hydro-electric power will come back to him through the medium of labor's purchase of his manufactured product.

On the score of economy, too, attention is called to the improvements made in recent years in the use of coal. Whereas in 1920 it required 3 lb. to generate 1 kw.hr. of electricity, in 1936 only 1.44 lb. was needed. The railroads also have registered an increase of 50 per cent in efficiency. Therefore, says N.C.A., in the face of increases in wages, mining costs, etc., improvement in product has not resulted in any actual advance in cost for coal even though the unit cost per ton has increased slightly from the low level of 1932.

To its bulletin of April 2 the association also attached a pink slip whereon was printed: "Why increase unemployment burdens? Burn coal for economy and reduce unemployment in mines, in factories, on railroads, on farms. The mining, transportation and distribution of coal is the major labor-employing industry, directly affecting millions of our population."

Alta Coal Co. Modernizes

Complete electrification and mechanization is under way at the Summit mine of the Alta Coal Co., Summiton, Ala. A new and much larger electric hoist has been installed and transmission lines have been constructed to bore holes to reach the inside operations, where additional power is required for the operation of electric locomotives, coal-cutting machines and additional pumps. A motor-generator set also is being installed, as well as preparation equipment to take care of a much larger output when needed, and the ventilating system is being extended and improved.

Congress TVA Probers Named

Quickly moving following the action of President Roosevelt in removing Dr. A. E. Morgan as chairman of the Tennessee Valley Authority when he refused to be specific in his charges against his associate directors, H. A. Morgan and David E. Lillienthal, both houses of Congress passed a resolution calling for a joint investigation of the government power project, and the President signed the measure on April 4.

Speaker Bankhead named these House members to the quiz group: James M. Mead, New York; William J. Driver, Arkansas; Ewing Thomason, Texas; Thomas A. Jenkins, Ohio, and Charles A. Wolverton, New Jersey. Designees by Vice-President Garner from the upper

Mechanical Stoker Sales Continue Decline

SALES of mechanical stokers in February last totaled 2,495 units, according to statistics furnished the U. S. Bureau of the Census by 112 manufacturers (Class 1, 60; Class 2, 33; Class 3, 27; Class 4, 23; Class 5, 11). This compares with sales of 2,423 units in the preceding month and 3,277 in February, 1937. Sales by classes in February last were: residential (under 61 lb. of coal per hour), 2,101 (bituminous, 1,640; anthracite, 461); small apartment-house and small commercial heating jobs (61 to 100 lb. per hour), 169; apartment-house and general small commercial heating jobs (101 to 300 lb. per hour), 116; large commercial and small high-pressure steam plants (301 to 1,200 lb. per hour), 72; high-pressure industrial steam plants (over 1,200 lb. per hour), 37.

Macwhyle Co.
Mancha Storage Battery Locomotive Co.
Marion Steam Shovel Co.
McGraw-Hill Publishing Co., Inc.
McLanahan & Stone Corporation
McNally-Pittsburg Mfg. Co.
Mechanization, Inc.
Metal & Thermit Corporation
Mineral States Exhibits
Mine Safety Appliances Co.
Mining Congress Journal
Morrow Mfg. Co.
Mosebach Electric & Supply Co.
Myers-Whaley Co.

Nachod & U. S. Signal Co., Inc.
National Carbide Co.
National Electric Coil Co.
National Malleable & Steel Castings Co.
National Tube Co.
Nordberg Mfg. Co.

Ohio Brass Co.
Penn Machine Co.
Pennsylvania Electric Coil Corporation
Phlice Radio & Television Corporation
Portable Lamp & Equipment Co.
Post-Glover Electric Co.
Princeton Foundry & Supply Co.
Productive Equipment Corporation
Prox, Frank, Co.
Pure Oil Co.

Roberts & Schaefer Co.
Robins Conveying Belt Co.
Roebling's, John A., Sons Co.
Robinson Ventilating Co.

Safety Mining Co.
Sanford-Day Iron Works, Inc.
Scully Steel Products Co.
Shell Petroleum Co.
Simplex Wire & Cable Co.
Socony Vacuum Oil Co.
Standard Oil Co. (Indiana)
Stephens-Adams Mfg. Co.
Sterling Pump Corporation
St. Louis Power Shovel Co.
Streeter-Amet Co.
Sullivan Machinery Co.
Sun Oil Co.

Talcott, W. O. & M. W., Inc.
Tamping Bag Co.
Templeton Kenly & Co.
Tennessee Coal, Iron & Railroad Co.
Tide Water Associated Oil Co.
Timken Roller Bearing Co.
Tool Steel Gear & Pinion Co.
Tyler, W. S., Co.
Tyson Roller Bearing Co.

Union Carbide & Carbon Corporation
United Engineers & Constructors, Inc.
United States Bureau of Mines
United States Steel Corporation
Universal Atlas Cement Co.
Universal Lubricating Co.
Utility Mine Equipment Co.

Viking Manufacturing Co.
Watt Car & Wheel Co.
Webster Manufacturing Co.
Weir Kilby Corporation
West Virginia Rail Co.
Western Cartridge Co.
Westinghouse Elec. & Mfg. Co.
White, H. Kirk, & Co.
Wilson Welder & Metals Co., Inc.
Wood Preserving Corporation

The program for the technical sessions appears on pp. 80 and 81.

Permissible Plate Issued

One approval of permissible equipment was issued by the U. S. Bureau of Mines in March, as follows: Myers-Whaley Co.—No. 3 size Automat loader; 30-hp. motor, 220 volts, a.c.; Approval 284; March 10.

Lesser Speaks on Physics

A paper on physics in coal mining, read by W. H. Lesser, electrical and mechanical engineer, Pierce Management, was a feature of a meeting of the Association of College of Physics Teachers held April 1 and 2 at Scranton, Pa. The meeting, which was sponsored by the University of Scranton, was held at the university. About 150 persons were in attendance from Eastern colleges and schools.

New **ECONOMIES**
in coal handling that lead to
greater **PROFITS**

VULCAN PRODUCTS

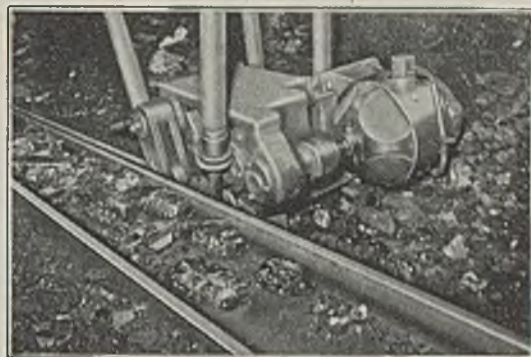

Shaking Conveyor Drives and Accessories in various Types and capacities for any mining requirement. Standard, explosion-proof and Government Approved permissible motors can be supplied for various current characteristics.

MORE and more, successful coal operators are looking towards operating economies for profit opportunities. Eighty-Nine Years of successful experience in the manufacture of mining equipment has taught us how to build an extra margin of strength and efficiency into every VULCAN product—an extra value that assures greater freedom from shutdowns, lower power costs, reduced maintenance costs, longer useful life, that result in profit opportunities which otherwise might be lost or absorbed through less efficient equipment.

That VULCAN QUALITY IS ALWAYS A GOOD INVESTMENT is indicated by the following partial list of VULCAN products—many of which are used throughout the entire mining world:

- | | |
|---|---|
| <i>Heavy Duty Electric Shaft Hoists</i> | <i>Mine Ventilating Fans</i> |
| <i>Steam Hoisting Engines</i> | <i>Coal Preparation Equipment</i> |
| <i>Self-Contained Hoists</i> | <i>Plate Metal Work, riveted and welded</i> |
| <i>Scraper Hoists</i> | <i>Steam Locomotives</i> |
| <i>Car Spotting Hoists</i> | <i>Electric Locomotives</i> |
| <i>Room Hoists</i> | <i>Gasoline locomotives geared and electric drive</i> |
| <i>Shaking Chute Conveyors</i> | <i>Diesel Locomotives, geared and electric drive</i> |
| <i>Sheaves, Pulleys, etc.</i> | |
| <i>Iron and Steel Castings</i> | |
| <i>Cages, Skips, Gunboats</i> | |

Write us regarding any requirement which involves coal handling, coal preparation, or mine ventilation. Our long experience has given us a vast fund of ideas and resources, which may easily help you to achieve important savings.

VULCAN IRON WORKS
WILKES-BARRE **PENNA.**

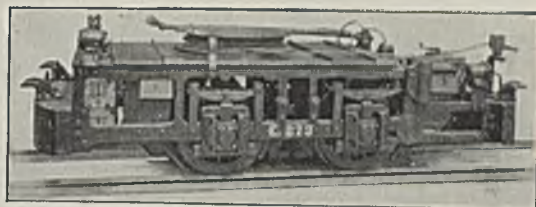

Electric Mining and Industrial Locomotives are built in sizes and types to suit any mine requirement.

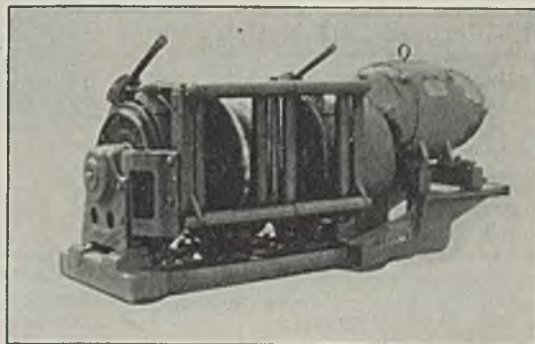

Vulcan Scraper Hoists are built in standard sizes, are compact and ruggedly constructed.



Mine Diesel Locomotives 4 to 12 tons weight, 30 to 100 HP. Built to suit special mine operating and haulage conditions.

house were: Vic Donahoy, Ohio; H. H. Schwartz, Wyoming; Fred H. Brown, New Hampshire; William E. Borah, Idaho, and Charles McNary, Oregon. Senators Borah and McNary, however, declined to serve, whereupon Senators Frazier, North Dakota, and Capper, Kansas, were named. Senator Capper also asked to be excused on the plea of being "too busy." Two other Senators are said to have declined to serve because of re-election campaigns.

Hudson Suit Dismissed

A petition filed on March 4 by six bondholders of the Hudson Coal Co. asking that the company be reorganized under Sec. 77B of the Federal bankruptcy laws and that a trustee be appointed to manage its affairs was dismissed at Scranton, Pa., on March 24 by United States Judge Albert W. Johnson. The court upheld the contention of counsel for the company that the court action was not taken in good faith, saying: "As it was admitted at the hearing that the six creditor petitioners purchased their bonds for the purpose of instituting this proceeding, such action shows the lack of good faith required by Sec. 77B of the Bankruptcy Act for which the petition must be dismissed."

The petitioners alleged that the company had assets of only \$31,652,000 and liabilities of \$73,968,250, whereas the company listed assets of \$96,678,614 and liabilities of \$56,478,590.

The bondholders who filed the petition, each owning a \$1,000 bond, were: Dr. Benjamin F. Yarowski, Wilmington, Del.; George J. Segal, Philadelphia, Pa.; John T. Duffy, Pottsville, Pa., and Joseph Kashan, Melva Solomon and Alex Sacher, all of Brooklyn, N. Y.

Personal Notes

GEORGE A. BLACKMORE, president, Westinghouse Air Brake Co., Wilmerding, Pa., has been elected a director of the Pittsburgh Coal Co., succeeding PAUL MELLON, resigned.

ALLEN J. JOHNSON, director of the Anthracite Industries Laboratory, at Primos, Pa., has been appointed a member of the committee on research of the Coal Division of the American Institute of Mining and Metallurgical Engineers.

LEONOR F. LOREE, president for the last 31 years of the Delaware & Hudson Co., holding company for the Delaware & Hudson R.R. and the Hudson Coal Co., and the oldest railroad chief executive in the country, resigned that post on March 30. Entering the service of the Pennsylvania R.R. in 1877, he has had a long and picturesque career, having at various times headed the Baltimore & Ohio; Chicago, Rock Island & Pacific; St. Louis & San Francisco, and Kansas City Southern roads.

CHARLES J. MAHER has been appointed assistant general superintendent by the H. C. Frick Coke Co., with headquarters at Uniontown, Pa., effective April 1. He succeeds W. C. Hood, who on Jan. 15 be-



Leonor F. Loree

came general superintendent of the United States Coal & Coke Co. Mr. Maher became associated with the company first in May, 1905, and, following a six-year period in private business, returned to the company in 1920. Since 1921 he had been superintendent at the Filbert mine, near Uniontown.

ROBERT V. WHITE, of the financial firm of Jackson & Curtis, Philadelphia, Pa., and W. DEERING HOWE, member of the law firm of Sherman & Sterling, New York City, have been elected to the board of directors of the Lehigh Coal & Navigation Co. They succeed William Jay Turner, who will continue as general counsel, and Robert C. Adams.

Rose Leases Kehley Run Mine

Kehley Run mine, an anthracite operation in Schuylkill County, Pennsylvania, formerly part of the Madeira-Hill chain, was leased by the Girard Estate on March 25 to Tony Rose, an independent operator, of Pittston. The new lessee planned to reopen the colliery promptly with about 400 employees.

Battelle Host to Salesmen

About 130 members of the Cincinnati domestic coal and stoker salesmen's school journeyed to the research laboratory of Bituminous Coal Research, Inc., at Battelle Memorial Institute, Columbus, Ohio, on March 29, where they inspected stokers and test equipment. Preceding the inspection, the group heard a discussion by R. C. Cross, fuel engineer at Battelle, comparing stokers, gas burners and oil burners.

The trip was the concluding session of a course conducted under the auspices of the Coal & Coke Merchants' Credit Association, Inc. (Cincinnati), the Cincinnati Coal Exchange, Appalachian Coals, Inc., and the Greater Cincinnati Stoker Association. Much credit for the success of the course was given to the efforts of J. E. Tobey, manager, fuel engineering division, and T. A. Day, assistant secretary, Appalachian Coals, Inc. The latter presided at the seven weekly meetings.

State of Washington Studies Its Mineral Resources

Sponsored by the University of Washington and the U. S. Bureau of Mines, two WPA "white collar" projects designed to establish new payrolls and aid the coal mining and mineral industries in the State of Washington are now in operation at the university, according to WPA Administrator Don C. Abel. The work is being conducted at the Northwest Experiment Station under the supervision of H. F. Yancey, of the Bureau of Mines.

Washington has larger coal deposits in well-known, easily accessible locations near the State's centers of population; the present projects were designed to supply accurate knowledge in order to stimulate the use of these supplies. A 65-page report gives details on a series of experiments conducted by WPA workers on the burning qualities of various kinds of coal by both the continuous and intermittent methods of utilizing overfeed stokers for domestic use. This report, which may soon be made available to the public, emphasizes the efficiencies of various types of coal-stoking furnaces at "medium and maximum" firing rates as compared with oil-burning furnaces of the intermittent type.

The second WPA project being conducted at the University College of Mines is the study of Washington's non-metallic minerals.

New Parrot Mine Ready Soon

Expenditure of \$300,000 for a tippie and machinery has been authorized by the North American Coal Corporation, Cleveland, Ohio, in connection with the opening of a new mine at Cabot, in Boone County, West Virginia, by the Parrot Coal Co., a North American subsidiary. Work on the structure began several weeks ago and machinery is being installed by the Kanawha Mfg. Co. The new mine is to start operating about Aug. 15, if market conditions justify it, according to John T. Sydnor, general superintendent for the company. Coal will be mined from the Five Block and Lewiston seams and five sizes will be produced. About five hundred men will be employed.

Industrial Notes

SIMPLEX WIRE & CABLE CO., Cambridge, Mass., has promoted William S. Davis to a vice-presidency; he had been sales manager since 1919, having joined the organization in 1896. George L. Roberts, assistant sales manager since 1927, succeeds Mr. Davis, and George A. Grauer, former executive secretary of the wire and cable section under NRA, becomes assistant sales manager.

PALMER-BEE CO., Detroit, Mich., announces that William E. Bee, president of the company since its founding, in 1905, has been made chairman of the board; George A. Bee has been named president and general manager; D. N. Sweeney assumes the office of secretary. J. E. McBride remains as vice-president; A. J.



SAMCO THE COST-CUTTER SAYS:

**"MORE AND MORE IMPORTANT
TIPPLE OPERATORS SPECIFY
REDLER CONVEYOR-
ELEVATORS"**

There's only one reason operators of these important tipples selected REDLER Conveyor-Elevators: Capable engineers found the REDLER the most efficient and economical solution for conveying and elevating fines and small sized coal.

Why? Because:

1. The REDLER conveys in any direction.
2. REDLERS are dust-tight.
3. They convey and elevate en masse, without degradation.
4. They are compact, requiring only 1/4 to 1/2 the space other units need.
5. REDLERS are low in first cost and operate with minimum power.

SOME OF THE TIPPLES USING REDLER CONVEYOR-ELEVATORS

- Allegheny River Mining Co.
- Atlas Coal Co. Ltd.
- Bell & Zoller Coal & Mining Co.
- Blackhawk Mining Corp.
- Blakley Coal Co.
- Buffalo Rock Coal Co.
- Chicago Wilmington & Franklin Coal Co.
- Clinchfield Coal Corp.
- Columbus Mining Co.
- Enos Coal Mining Co.
- Gay Coal and Coke Company
- Greenville Coal Co.
- Greenwood Coal Company
- Heisley Coal Co.
- Island Creek Coal Co.

It Costs LESS To Be MODERN

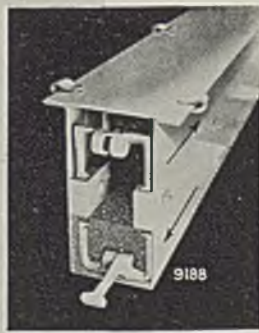
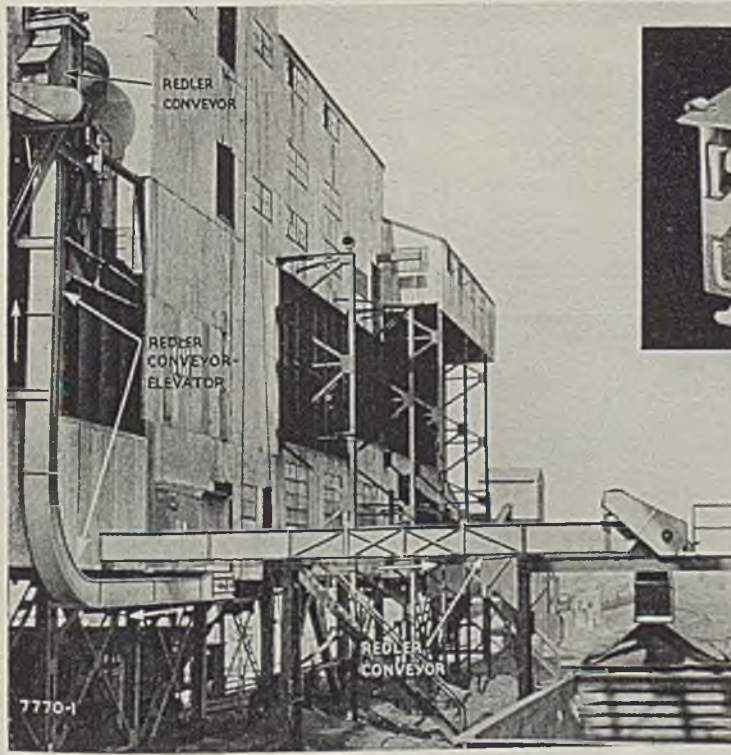

- Jones Collieries, Inc.
- Kentucky Jellico Coal Co.
- Keystone Coal & Coke Co.
- Kingston-Pocahontas Coal Co.
- Knox Consolidated Coal Co.
- Lake Erie Mining Co.
- New River Company
- Northern Illinois Coal Corp.
- Peabody Coal Co.
- Pittsburgh Coal Co.

- Pittsburgh and Midway Coal Mining Co.
- Sahara Coal Company
- Snow Hill Coal Co.
- Sunlight Coal Co.
- Sunshine Coal Co.

- Tennessee Coal, Iron & RR Co.
- Union Coal Co.

ONE REDLER BOTH CONVEYS AND ELEVATES COAL

Three of five REDLERS at southern Illinois cleaning plant convey and elevate sized, dedusted bituminous coal en masse. REDLER at right conveys to dust loading track.

INVESTIGATE AIR-SAND DRY COAL CLEANING AND REDLER CONVEYORS AT THE CINCINNATI COAL SHOW — BOOTHS 216 AND 218



ASK FOR REDLER CATALOG 42

Fully illustrated engineering information on all types REDLER Conveyor-Elevators



AIR SAND DRY COAL CLEANING SYSTEM . . . COMPLETE COAL TIPPLES CONVEYING . . . ELEVATING . . . SCREENING . . . TRANSMISSION EQUIPMENT

STEPHENS-ADAMSON MFG. CO.

Leckie is treasurer; C. F. McLaren is assistant treasurer; L. F. Miller is assistant secretary.

HARNISCHFEGGER CORPORATION, Milwaukee, Wis., has appointed H. S. Strouse as vice-president. He will continue to direct the activities of the treasurer's department of the company, with which he has been connected since 1920.

Alabama Rate Cut Allowed

Alabama railroads were authorized by the State Public Service Commission on March 24 to reduce rates on coal shipped from mines to Mobile from \$1.90 to \$1.40 and \$1.50 per ton. The Alabama Great Southern, Louisville & Nashville, Northern Alabama and Southern Ry. were given authority to establish the lower rate, and the Illinois Central to set the \$1.50. The carriers contended that the reductions were necessary "because of unregulated barge-line competition."

Train-Limit Bill Killed

The Interstate Commerce Committee of the House of Representatives at Washington on March 31 killed a bill approved last summer by the Senate which would limit the length of freight trains to 70 cars. The committee voted 14 to 7 against reporting the bill. The action of the committee followed two months of hearings during which representatives of the railroads contended that the additional cost that would result from enactment of the measure would further weaken their financial position. Representatives of the railroad unions urged, however, that a limit on the size of trains would reduce accidents and increase employment.

To Survey Marketing Laws

A project to survey State marketing laws throughout this country has been approved, according to an announcement on April 3 by Corrington Gill, assistant administrator of the Works Progress Administration. The survey is designed to obtain legal and economic data concerning laws on State statute books and make it available in convenient form to all Federal and State governmental agencies, trade associations, businessmen and others. It is expected also to supply data for evaluating conflicting claims on these laws. Mr. Gill, who will supervise the work, has appointed A. H. Martin as director, and Dr. John H. Cover and Mark Merrell as associate directors.

Cooperation and advice for both planning and execution of the survey will be sought from trade and professional associations and individuals affected by the State marketing laws, and a Federal advisory committee will be established, on which representatives from the following bureaus will be asked to serve: Departments of Commerce, Justice and the Treasury, Federal Trade Commission, Bureau of Agricultural Economics, Consumers Council of AAA, Consumers' Counsel of the Coal Commission, Business Advisory Council, Bureau of Labor Statistics, and National Resources Board.

Reestablishment of Prices on the Way; Holt Takes Fling at Commission

WASHINGTON, D. C., April 11—With hearings planned to determine the weighted average cost of coal, upon minimum prices proposed by the district producers' boards, and upon prices proposed by the Commission itself the National Bituminous Coal Commission is well advanced with preparations for the reestablishment of schedules. A hearing on the question of reasonable discounts or price allowances for distributors has been set for April 25. Representatives of the 22 district boards met with the Commission on March 30 to discuss new procedure for again setting minimums, with John Carson, Consumers' Counsel, participating in the interest of the consuming public, upon the suggestion of Percy Tetlow, temporary chairman. In opening the meeting, Mr. Tetlow said the Commission intended to proceed with dispatch but with caution to establish new prices at the earliest possible date in full accordance with the law. "By no other plan can the marketing of bituminous coal be on a successful basis than by the application of the law itself," Mr. Tetlow declared.

Miss Josephine Roche, president and general manager of the Rocky Mountain Fuel Co., told the Commissioners that in her opinion Federal legislation and regulation are essential to the industry. "All groups concerned in its welfare and progress—the investors, management, labor and the public—have a vital stake in sound and constructive regulation," she averred. "For years it has been demonstrated that without government regulation, chaos has prevailed in the industry, with labor, the people, and management all paying a heavy and tragic penalty. During even the brief periods of Federal

regulation we have known, all parties have benefited and made progress."

That no court has pronounced prices established by the Commission invalid, and that the Commission's order revoking minimums did not declare price schedules and orders invalid was pointed out by Robert W. Knox, general counsel of the Commission, on March 26. Order No. 230, he explained, "revoked certain prior orders of the Commission for the reason that they had become inoperative due to causes beyond the control of the Commission, and the express intention of Congress, as provided in Sec. 4, Part II (a) and (b) of the Coal Act of 1937, cannot be effectuated by the minimum prices remaining in effect, and the condition thereby created is detrimental to the interest of code members." Final determination of the issues, declared Mr. Knox, was expressly reserved until such time as the Commission could certify to the courts complete records for review. Several days later, the Commission issued a ruling construing the 1937 act to permit the introduction in evidence at a hearing before it or in a court of the 1936 cost data of individual coal producers obtained under authority of the act for the establishment of minimum prices.

Although it was announced several weeks ago that the resignation of Chairman Charles F. Hosford, Jr., from the Commission would take effect on April 30, President Roosevelt accepted it as of last Wednesday. Taking occasion to excoriate the Commission in the Senate the same day, Senator Rush D. Holt, of West Virginia, declared that Mr. Hosford's resignation was because of a "fight between Mr. Tetlow and Mr. Hosford and the desire of John L. Lewis, U.M.W.

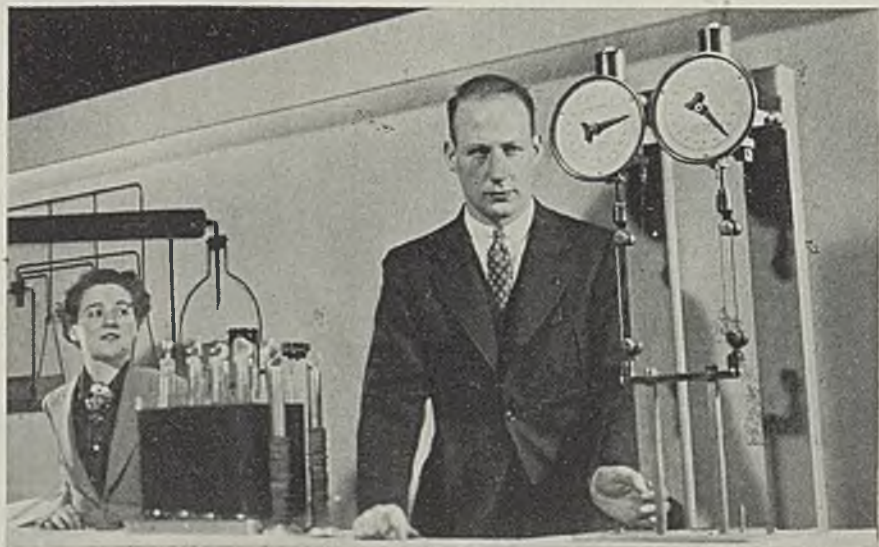

Rubber made from coal stands up

A preliminary step in a test of the tensile strength of neoprene—a chloroprene rubber made from a coal base—in comparison with natural rubber after immersion in hot oil at 140 deg. F. for three days shows that the neoprene ring retains its original strength, breaking at approximately 73 lb., whereas the natural rubber ring has so deteriorated that it breaks at about 20 lb. Demonstration given at the Du Pont exhibition, Museum of Science and Industry, Rockefeller Center, New York City.

YOUR COAL . . . *determines* the ~~SCREEN SPEED~~ of the **ROBINS GYREX**

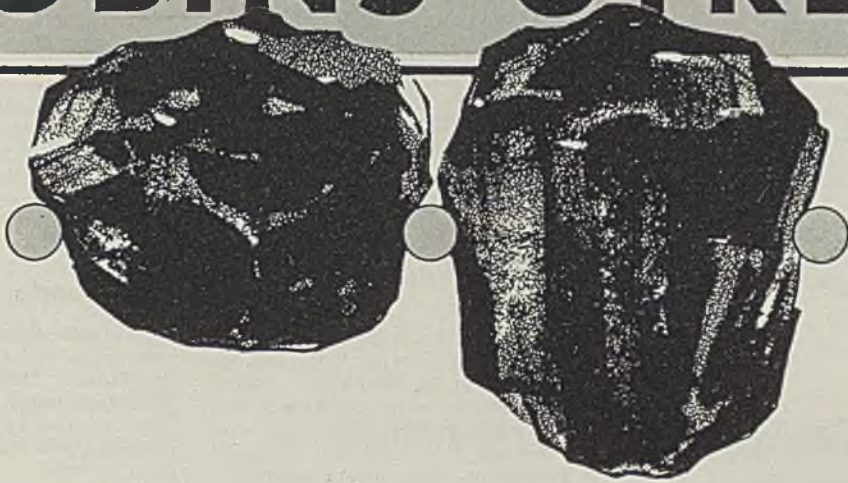

NATURALLY, columnar shaped coal requires a greater speed than cubical coal to dislodge it from the screen openings. The user's coal is carefully studied by Robins

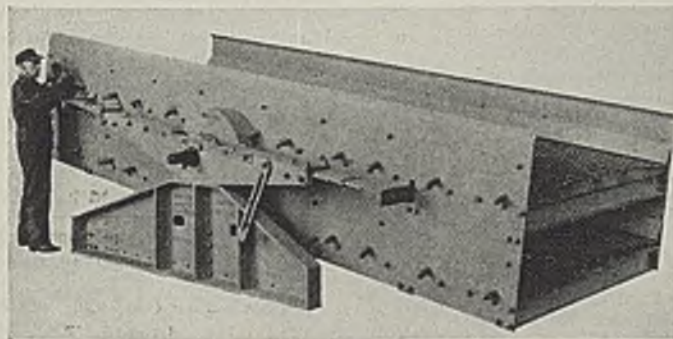

Engineers when supplying a Gyrex Screen. The speed of the screen, the amplitude of stroke in relation to the required size of openings, are considered to give the greatest efficiency and capacity with the minimum of breakage. Robins Gyrex Screens are being used more and more for primary screening. With their speed, greater than older types of primary screens, they handle greater tonnage, require less floor space and use less power . . . and best of all, they screen more accurately with less breakage.

Robins Makes:

Belt, Chain and Pivoted Bucket Conveyors, Bucket Elevators, Hoists, Grab Buckets, Mine Conveyors, Screens, Crushers, Gates, Feeders, Chutes, and Complete Preparation Plants. Send for bulletins describing products of interest to you.

MATERIAL HANDLING
ROBINS
 EQUIPMENT

Visit our booths 211 and 213 at the Coal Convention in Cincinnati, May 2 to 6

ROBINS CONVEYING BELT COMPANY, 15 Park Row, New York, N. Y.

Please send me bulletin describing

Name

Firm

Address

City State

president, to be boss of the Commission. He has gotten the official head of one man," added Senator Holt, "and I understand that he is after the head of some of the others who would not take his orders."

The occasion for the West Virginia Senator's remarks was the vote which increased the Commission's share of the Interior Department appropriation bill from \$2,700,000 to \$3,000,000. This increase was characterized by him as necessary "to put a few more hungry politicians on the payroll in order to help carry the States of Pennsylvania, Ohio and Kentucky."

Financial Reports

Island Creek Coal Co. and subsidiaries—Net profit for 1937, \$1,527,776, compared with \$1,238,421 profit in 1936.

Philadelphia & Reading Coal & Iron Co. (anthracite activities)—Net loss for 1937, after surtax, \$6,353,848, compared with \$3,508,756 loss in 1936.

Westmoreland Coal Co.—Net profit for 1937, \$155,469, compared with \$68,294 profit in 1936.

Fourseam Tipple Destroyed

The tipple of the Fourseam Coal Co., at Diablock, Ky., was destroyed by fire on March 23, entailing a loss estimated by Frank King, manager, in excess of \$75,000. More than 200 miners will be idle about six months, said Mr. King, pending reconstruction.

Volpe Takes Butler Colliery

Operation of the Butler colliery of the Pittston Co., at Dupont, Pa., has been taken over by the Volpe Coal Co., of Pittston, a lease having been signed on March 31. The lessee plans to work the mine with a full force of 800 men. This makes the fourth Pittston operation turned over to the Volpe company, the others, starting in 1934, being the No. 6, at Inkerman; Sibley, at Old Forge; and the Forest City colliery, at Forest City.

Obituary Notes

EDWIN F. SAXMAN, 72, president of the Saxman Coal & Coke Co., with operations in Somerset County, Pennsylvania, and Nicholas County, West Virginia, died April 5 at his home in Villanova, Pa. The son of coal operator, he founded the company bearing his name about 30 years ago.

ALBERT P. BUSH, vice-president and a director of the Alabama By-Products Corporation, died April 8 at his home in Mobile, Ala., after about a year of failing health. In collaboration with his brother, the late Morris W. Bush, and the late Horace Hammond, he organized the Birmingham Coke & By-Products Corporation, which was later merged with the Pratt Consolidated Coal Co. to form the



Malcolm Macfarlane

present Alabama By-Products Corporation, the largest commercial coal producer in the Alabama field.

MALCOLM MACFARLANE, coal inspector for the New York Central R.R., lost his life by drowning on March 20 when a log raft on which he was making a trip down the Susquehanna River was capsized. He had been with the company for a number of years before leaving to become associated with the Bird Coal Co. for a time. He returned to the Central, however. His body was recovered on March 28.

Purchasing Agents to Convene

The 23d annual convention of the National Association of Purchasing Agents and Inform-a-Show will be held May 23-26 at St. Louis, Mo. As evidence of the interest and enthusiasm in this year's get-together prospective exhibitors had taken all the available space within 24 hours of the opening for reservations.

More Bootleg Miners Quit Work

Fifteen hundred independent miners on April 2 halted deliveries to breakers handling coal taken from abandoned shafts and holes in Schuylkill and Northumberland counties, Pennsylvania, demanding higher prices. The free lancers voted to hold out for 6½c. per cubic foot at the mines and 8½c. delivered to the breakers, as compared with the prevailing rates of 5½ and 7c., respectively. P. J. Brennan, president of the Independent Miners' Association of the two counties, said that unless the increases were granted the free lancers would lease breakers of their own.

More Fellowships Offered

Four appointments as research associates at \$1,800 per year are being made available at Battelle Memorial Institute, Columbus, Ohio. The appointments are open to graduates of any accredited colleges or universities, preference being given to those who have demonstrated marked

aptitude for scientific research in their industrial experience or by graduate study in chemistry, physics, metallurgy or ceramics. Though appointments will be for one year's duration, including vacation, they may be extended for a second year. Application should be made to Clyde E. Williams, director.

West Virginia University, in cooperation with the Calcium Chloride Association, offers a fellowship in coal preparation for the school year 1938-9, beginning July 1. The applicant will be required to register as a student for graduate work in the university, leading to an advanced degree, eligibles being graduates or students who will complete their college work in the coming June, who have had thorough training in the physical sciences and who are especially qualified to do research work. The work will be on the use of calcium chloride in the treatment and preparation of bituminous coal, the student being granted a stipend of \$1,000 and free tuition for twelve months.

Alberta Blast Kills Five

Five men were killed and six seriously injured in an explosion on March 30 at the Hinton Collieries, Hinton, Alberta. The blast, which occurred at the 800-ft. level, apparently killed four of the men instantly, and the fifth died shortly afterward.

Link-Belt Expands Stoker Line

Further expansion of its stoker line is announced by Link-Belt Co., Philadelphia, Pa., through the acquisition of patent and sales rights to the Super-Stoker. The new owner assumes complete responsibility for engineering, research and design on this anthracite burner, hitherto manufactured by the John Wood Manufacturing Co. A new model anthracite stoker also is to be announced in the near future by Link-Belt, to embody modern improvements with the same basic principles heretofore employed.

New Kingston-Pocahontas Office

New offices for some of the management personnel have been established at Bluefield, W. Va., in the Perry Building by the Kingston-Pocahontas Coal Co., which has large operations in southern West Virginia and eastern Kentucky. Among those who will occupy the new quarters are: C. N. Scott, general manager of mines, whose offices heretofore have been in New York; J. S. Replogle, general store superintendent, of Ashland, Ky., and his assistant, E. M. Moore, also of Ashland.

Trade Literature

AUTOMATIC CONTROLS—Mercoid Corporation, Chicago (Catalog No. 200, 36 pp., illustrated). Details characteristics and special features of Mercoid automatic controls for heating, air conditioning, refrigeration and various types of industrial applications.

CENTRIFUGAL PUMPS—DeLaval Steam Turbine Co., Trenton, N. J. (16-pp. book-

let, illustrated). Shows the special features of single-stage and multi-stage units for small and large capacities and for all heads.

COAL-CUTTING EQUIPMENT—Goodman Manufacturing Co., Chicago. Bulletin M-374 (12 pp.) describes the Type 824 track-mounted slabber, a combination top-, center- and bottom-cutting machine with a roll-over head for inverting the cutter arm; the adjustment of the cutter arm for cutting height, and all tramming and cutting movements are accomplished by power which is controlled by conveniently placed levers. Bulletin M-375 (10 pp.) features three top- and center-cutting slabbing machines: Type 124, with standard-height top and center cutter, and Types 224 and 1124, with low-vein top and center cutters. Bulletin M-376 (12 pp.) presents the Type 724 gobber, designed especially to cut out a band of rock, slate or other impurity from the seam, convey it from the face and deposit into mine car or gob pile; a double cutter-arm arrangement permits the cutting of a kerf of any thickness up to 20 in.

CONTROLS—General Electric Co., Schenectady, N. Y. GEA-2473 (12 pp.) describes pushbutton stations and other CR2940 manual electric units for use in the control circuits of magnetic controllers. GEA-2728 covers Type AL-2 air-breaker equipments for low-voltage a.c. circuits.

DIESEL-ELECTRIC POWER UNITS—Caterpillar Tractor Co., Peoria, Ill. (12-pp. booklet, illustrated). Cites a wide range of uses for these units with illustrations showing actual installations and the type of work being done; also gives listed ratings of the eight sizes now available.

DIRECT-CURRENT MOTORS—Fairbanks, Morse & Co., Chicago (8 pp., illustrated). Details the construction features of small, intermediate and large motors with a variety of mechanical modifications for both high- and low-voltage operation designed to meet a wide range of requirements.

ELASTIC STOP NUTS—Elastic Stop Nut Corporation, Elizabeth, N. J. (48-pp. catalog, illustrated). Portrays the salient characteristics of self-locking nuts, giving a variety of applications under severe service conditions.

ENGINEERING SERVICE—Stuart, James & Cooke, Inc., New York City (20 pp.). Gives a brief outline of industrial principles applied to mining which have proved of benefit to many mining companies. The subject matter is based on the results and observations of the firm and its associates accumulated over a quarter of a century by men experienced in service to the mining industry in this and other countries.

EYE PROTECTIVE EQUIPMENT—Mine Safety Appliances Co., Pittsburgh, Pa. (Bulletin CE-4, 8 pp., illustrated). Fully describes and illustrates appliances for eye protection, including goggles, spectacles, lenses, helmets, etc., of every type and design used by workers in mining, welding, construction, automotive, steel, petroleum, machinery, glass, quarry and other industrial fields.

HEAVY DUTY PUSHBUTTONS—Westinghouse Electric & Mfg. Co., East Pitts-

"Here's the answer to the coal washing problem where conservation of space is highly important"

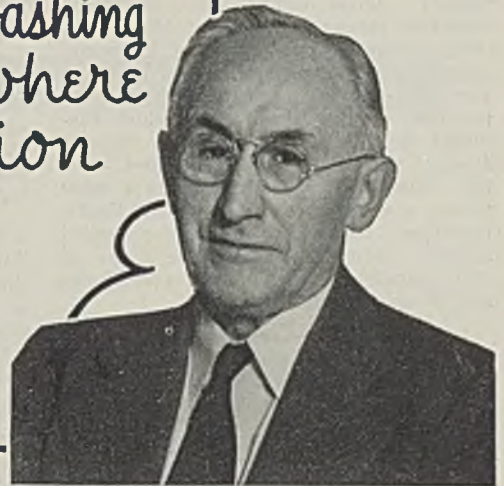

EMIL DEISTER, SR.
President Deister Machine Co.

THE NEW DEISTER PLAT-O COAL WASHING TABLE . . .

Cleans much larger tonnages, effecting a marked saving in the space now required for this work.

New contour of the deck surface; new system of ruffling; more effective differential action of the Plat-O Headmotion enable this table to handle much larger tonnages per unit of occupied floor space.



COAL WASHING TABLE

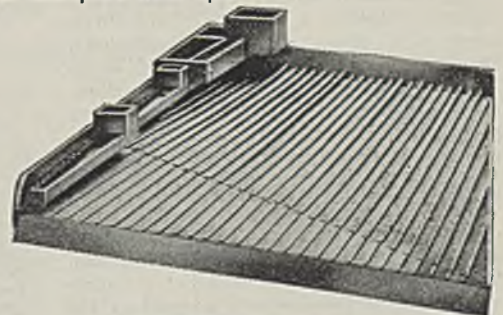

To twenty-six years of constant experimentation and engineering development goes the credit for such an amazing improvement in operating efficiency. The Deister Machine Company, specialists in the field since 1912, invites your inquiries with the firm conviction that under your own particular operating conditions an installation of one or more units will prove an extremely profitable investment.

AT THE SHOW

Plan now to investigate the
Plat-O Coal Washing Table
at

Booth 832
Convention Floor

DEISTER MACHINE COMPANY

1933 E. WAYNE STREET

(INCORPORATED 1912)

Cable Address "Deister"

FORT WAYNE, INDIANA

EMIL DEISTER, SR., Pres. • I. F. DEISTER, V. Pres. • EMIL DEISTER, JR., Secy. Treas.

Manufacturers of PLAT-O Coal Washing Tables, PLAT-O Ore Concentrating Tables, Heavy Duty PLAT-O Vibrating Screens, Deister Compound Funnel Classifiers.

Large Ho. (Price 15¢, 12-101, 4 pp., illustrated). Describes salient features of the company's extensive line of fully motor stations for a wide variety of applications.

INDUSTRIAL FRICTION MATERIALS—Johns-Manville, New York (9 pp., 115 illustrations). Gives comprehensive data on industrial brake linings and blocks and clutch linings for all types of industrial equipment. Included is a chart in which are recommended grades and finishes of the disk ends and band types which simplify the selection of the most suitable friction material for any specified work. Supplementing the chart is a table giving coefficient of friction, air limits, thickness, advances and recommended service conditions for various types of S.M. industrial brake linings and blocks and clutch linings.

LARGE JACKS—Inch-Norm, Mfg. Co., Pittsburgh, Pa. (Illustrated folder). It carries complete line of "Power-In-Serv-ice" lifting jacks for every mining requirement and service.

Motor-Generators, Etc.—Allis-Chalmers Manufacturing Co., Milwaukee, Wis. Bulletin 1152, 24 pp., illustrated. Reports the modern construction of motor-generator sets for use in mines, steel mills, electric and other services. Division is made into sections describing direct-current generator, synchronous motor, induction motor-generator, special sets, frequency change sets, and sets for special applications, and control equipment.

NEWEST CABLES—American Wire & Cable Co., New York (Publication No. 108, 8 pp., illustrated). Treats of the characteristics of ANW cables giving a general description of its use in industrial applications and light building.

ON JACOBSON'S MINE SYSTEM—Washington Electric & Mfg. Co., Wash. D.C. (12 pp., 10 illustrations, illustrated). Details the progressive features of Washington Electric Co.'s immersed motor system for plants where immersion in acid or gas may be present. A table is included giving range of sizes and recommended schedule to meet exact requirements.

PERMANENT ELECTRIC TOOLS—Rock & Trench Manufacturing Co., Boston, Mass. Two catalogs, 40 pp., each, list the complete line of the company as well as the Van Dorn Electric Tool Co. divisions. Descriptions, specifications and prices are included.

SAFETY DEVICES—American Optical Co., Springfield, Mass. (10 pp., folder). A complete and complete chart describing of hazardous operations by industries and recommending specific types of safety rescue equipment developed for each hazard.

SMALL PUMP INSTRUMENTS—General Electric Co., Schenectady, N. Y. (4-pp. folder). Succinctly describes all types of instruments designed for a wide range of application and combining beauty with accuracy.

STEEL ROLLERS AND SUPPORTS—American Steel & Wire Co., New York (Bulletin No. 10, 10 pp., illustrated). Reports the many types of design and design for roller supports giving specifications.

TRUSSINGS FOR PULVERISERS—S. E. Decker Manufacturing Co., Bradford, Pa. (Form 281, 16 pp., illustrated). Describes fittings designed to be unique types of self-contained joints that connect pipe without threading, all that are needed are one of these fittings, plain end pipe, and a wrench.

TRUCKS—Allis-Chalmers Manufacturing Co., Milwaukee, Wis. Form M.S. 222, a 3-pp. catalog, details striking features of Model "50" unit with specifications and extra equipment and attachments. Form M.S. 225 (40 pp.), entitled "Tractor Power," covers the company's complete industrial line.

TRACTOR-POWER SYSTEMS—F. G. LeTourneau, Inc., Fort Worth, Tex. (3-pp. folder, illustrated). Details outstanding features of the G-4 Caterpillar, which although a departure in design from former models, retains the same positive loading and unloading advantages.

VENTILATION SYSTEMS—Reich Bros. Bag Co., St. Louis, Mo. (28-pp. booklet, illustrated). Discusses fittings for mine and tunnel ventilation, setting forth its advantages and applications.

WINDING SYSTEMS—Decker Construction Co., Fort Worth, Ind. (Bulletin No. 14-11, 24 pp., illustrated). Describes and pictures the latest mechanical improvements, coordinated with the fundamental characteristic principles of operation, of the Model C Leaky heavy-duty "No-Blind" winding system.

WIRE ROPE—Barnard Wire Rope Division, American Chain & Cable Co., Inc.

WIRE ROPE, PA. (28 pp., illustrated). A treatise, entitled "Wire Rope's Natural Enemies," on the many things that wear out rope and how either to avoid them or minimize their effect. Shows, reverse bends, kinking, whipping, abrasion and many other enemies of wire rope are discussed separately and in simple, non-technical language. Included are several "Service Record" forms which the rope user can utilize in keeping track of machine production and rope service.

Coal-Mine Fatality Rate Registers Increase

Accidents at coal mines of the United States caused the deaths of 60 mine-men and 26 anthracite miners in February last, according to reports furnished the U. S. Bureau of Mines by State inspectors. With a production totaling 27,000,000 tons, the death rate among bituminous miners was 2.21 per million tons, compared with 2.14 in the corresponding month of last year.

The anthracite fatality rate in February last was 2.58, based on an output of 3,225,000 tons, as against 3.15 in February a year ago.

For the two industries combined, the death rate in February last was 2.55, compared with the preliminary figure of 2.67 in the preceding month and a revised figure of 2.45 in February, 1937.

Fatalities during February last, by cause and State, as well as comparative rates for the first two months of 1937 and 1938, by causes, are given in the accompanying table.

COAL-MINE FATALITIES IN FEBRUARY 1938, BY CAUSES AND STATES

State	Type of fatality										Grand total	
	Falls of roof	Falls of face	Hoisting	Use of dust explosion	Explosives	Electricity	Other machinery	Other causes	Total underground	Total shaft		
Alabama	1	1	1	1	1	1	1	1	1	1	1	1
Arizona	1	1	1	1	1	1	1	1	1	1	1	1
Arkansas	1	1	1	1	1	1	1	1	1	1	1	1
California	1	1	1	1	1	1	1	1	1	1	1	1
Colorado	1	1	1	1	1	1	1	1	1	1	1	1
Connecticut	1	1	1	1	1	1	1	1	1	1	1	1
Delaware	1	1	1	1	1	1	1	1	1	1	1	1
District of Columbia	1	1	1	1	1	1	1	1	1	1	1	1
Florida	1	1	1	1	1	1	1	1	1	1	1	1
Georgia	1	1	1	1	1	1	1	1	1	1	1	1
Idaho	1	1	1	1	1	1	1	1	1	1	1	1
Illinois	1	1	1	1	1	1	1	1	1	1	1	1
Indiana	1	1	1	1	1	1	1	1	1	1	1	1
Iowa	1	1	1	1	1	1	1	1	1	1	1	1
Kentucky	1	1	1	1	1	1	1	1	1	1	1	1
Louisiana	1	1	1	1	1	1	1	1	1	1	1	1
Maine	1	1	1	1	1	1	1	1	1	1	1	1
Massachusetts	1	1	1	1	1	1	1	1	1	1	1	1
Michigan	1	1	1	1	1	1	1	1	1	1	1	1
Minnesota	1	1	1	1	1	1	1	1	1	1	1	1
Mississippi	1	1	1	1	1	1	1	1	1	1	1	1
Missouri	1	1	1	1	1	1	1	1	1	1	1	1
Montana	1	1	1	1	1	1	1	1	1	1	1	1
Nebraska	1	1	1	1	1	1	1	1	1	1	1	1
Nevada	1	1	1	1	1	1	1	1	1	1	1	1
New Hampshire	1	1	1	1	1	1	1	1	1	1	1	1
New Jersey	1	1	1	1	1	1	1	1	1	1	1	1
New Mexico	1	1	1	1	1	1	1	1	1	1	1	1
New York	1	1	1	1	1	1	1	1	1	1	1	1
North Carolina	1	1	1	1	1	1	1	1	1	1	1	1
North Dakota	1	1	1	1	1	1	1	1	1	1	1	1
Ohio	1	1	1	1	1	1	1	1	1	1	1	1
Oklahoma	1	1	1	1	1	1	1	1	1	1	1	1
Oregon	1	1	1	1	1	1	1	1	1	1	1	1
Pennsylvania	1	1	1	1	1	1	1	1	1	1	1	1
Rhode Island	1	1	1	1	1	1	1	1	1	1	1	1
South Carolina	1	1	1	1	1	1	1	1	1	1	1	1
South Dakota	1	1	1	1	1	1	1	1	1	1	1	1
Tennessee	1	1	1	1	1	1	1	1	1	1	1	1
Texas	1	1	1	1	1	1	1	1	1	1	1	1
Utah	1	1	1	1	1	1	1	1	1	1	1	1
Vermont	1	1	1	1	1	1	1	1	1	1	1	1
Virginia	1	1	1	1	1	1	1	1	1	1	1	1
Washington	1	1	1	1	1	1	1	1	1	1	1	1
West Virginia	1	1	1	1	1	1	1	1	1	1	1	1
Wisconsin	1	1	1	1	1	1	1	1	1	1	1	1
Wyoming	1	1	1	1	1	1	1	1	1	1	1	1
Total	60	26	26	26	26	26	26	26	26	26	26	26

FATALITIES AND DEATH RATES AT UNITED STATES COAL MINES, BY CAUSES

	January-February 1937		January-February 1938		Total	Rate per million tons
	Number killed	Rate per million tons	Number killed	Rate per million tons		
Falls of roof and face	157	1.25	157	1.25	314	1.25
Hoisting	11	0.09	11	0.09	22	0.09
Use of dust explosion	1	0.01	1	0.01	2	0.01
Total	169	1.35	169	1.35	338	1.35
Explosives	1	0.01	1	0.01	2	0.01
Electricity	1	0.01	1	0.01	2	0.01
Other machinery	1	0.01	1	0.01	2	0.01
Other causes	1	0.01	1	0.01	2	0.01
Total	5	0.04	5	0.04	10	0.04
Total	174	1.39	174	1.39	348	1.39

All figures subject to revision.